

LISTINO LO - 2022

**10**

[www.attrezzaturearredi.it](http://www.attrezzaturearredi.it)

**ITALIA**

**LISTINO PREZZI**

CUCINE MODULARI PROF.

50 - 55 - 60 - 65 - 70 - 90



# COLORE 60-70-90

MOD. \_\_\_\_\_  
COD. \_\_\_\_\_

DESCRIZIONE/DESCRIPTION/BEZEICHNUNG/DESCRIPTION/DESCRIPCIÓN  
DIMENSIONI/DIMENSIONS/ABMESSUNGEN/DIMENSIONS/DIMENSIONES

POTENZA/POWER/LEISTUNG/PUISSANCE/POTENCIA  
VOLTAGGIO/VOLTAGE/SPANNUNG/VOLTAGE/VOLTAJE

⚡ kW kcal/h  
⚡ kW V~ Hz

PREZZO/PRICE €  
PREIS/PRIX/PRECIO €  
KG / M<sup>3</sup>

**RAL9005**

**SOVRAPPREZZO PORTA E PANNELLO  
COMANDI SERIE 60/70/90 VERNICIATI  
RAL9005 OPACO "NERO INTENSO"**  
EN EXTRA COST for door and control panel of  
60/70/90 series painted RAL9005 opaque "JET  
BLACK"  
cm.30÷40



**180,00**  
/



**RAL9005**

**RAL9016**

**SOVRAPPREZZO PORTA E PANNELLO  
COMANDI SERIE 60/70/90 VERNICIATI  
RAL9016 OPACO "BIANCO TRAFFICO"**  
EN EXTRA COST for door and control panel of  
60/70/90 series painted RAL9016 opaque "TRAFFIC  
WHITE"  
cm.30÷40



**180,00**  
/



**RAL9016**

**RAL7024**

**SOVRAPPREZZO PORTA E PANNELLO  
COMANDI SERIE 60/70/90 VERNICIATI  
RAL7024 OPACO "GRIGIO GRAFITE"**  
EN EXTRA COST for door and control panel of  
60/70/90 series painted RAL7024 opaque "GRAPHITE  
GREY"  
cm.30÷40



**220,00**  
/



**RAL7024**

**RAL3000**

**SOVRAPPREZZO PORTA E PANNELLO  
COMANDI SERIE 60/70/90 VERNICIATI  
RAL3000 OPACO "ROSSO FUOCO"**  
EN EXTRA COST for door and control panel of  
60/70/90 series painted RAL3000 opaque "FLAME  
RED"  
cm.30÷40



**220,00**  
/



**RAL3000**

**RAL2004**

**SOVRAPPREZZO PORTA E PANNELLO  
COMANDI SERIE 60/70/90 VERNICIATI  
RAL2004 OPACO "ARANCIO PURO"**  
EN EXTRA COST for door and control panel of  
60/70/90 series painted RAL2004 opaque "PURE  
ORANGE"  
cm.30÷40



**220,00**  
/



**RAL2004**

**RAL5015**

**SOVRAPPREZZO PORTA E PANNELLO  
COMANDI SERIE 60/70/90 VERNICIATI  
RAL5015 OPACO "BLU CIELO"**  
EN EXTRA COST for door and control panel of  
60/70/90 series painted RAL5015 opaque "SKY BLUE"  
cm.30÷40



**220,00**  
/



**RAL 5015**

# COLORE 60-70-90

MOD. \_\_\_\_\_  
COD. \_\_\_\_\_

DESCRIZIONE/DESCRIPTION/BEZEICHNUNG/DESCRIPTION/DESCRIPCIÓN  
DIMENSIONI/DIMENSIONS/ABMESSUNGEN/DIMENSIONS/DIMENSIONES

POTENZA/POWER/LEISTUNG/PUISSANCE/POTENCIA  
VOLTAGGIO/VOLTAGE/SPANNUNG/VOLTAGE/VOLTAJE

$\frac{kW}{kcal/h}$   $\frac{V}{Hz}$

PREZZO/PRICE €  
PREIS/PRIX/PRECIO €  
KG / M<sup>3</sup>

**RAL EXTRA SOVRAPPREZZO PORTA E PANNELLO  
COMANDI SERIE 60/70/90 VERNICIATI RAL A  
SCELTA FUORI LISTINO**  
EN EXTRA COST for door and control panel of  
60/70/90 series painted RAL extra price list  
cm.30÷40



250,00 /

**RAL9005 TMA1 SOVRAPPREZZO TESTATA 1 LATO SERIE  
60/70/90 VERNICIATA RAL9005 OPACO  
"NERO INTENSO"**  
EN EXTRA COST for lateral finish panel 1 side of  
60/70/90 series painted RAL9005 opaque "JET  
BLACK"



220,00 /



RAL9005

**RAL9016 TMA1 SOVRAPPREZZO TESTATA 1 LATO SERIE  
60/70/90 VERNICIATA RAL9016 OPACO  
"BIANCO TRAFFICO"**  
EN EXTRA COST for lateral finish panel 1 side of  
60/70/90 series painted RAL9016 opaque "TRAFFIC  
WHITE"



220,00 /

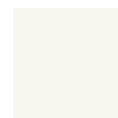

RAL9016

**RAL7024 TMA1 SOVRAPPREZZO TESTATA 1 LATO SERIE  
60/70/90 VERNICIATA RAL7024 OPACO  
"GRIGIO GRAFITE"**  
EN EXTRA COST for lateral finish panel 1 side of  
60/70/90 series painted RAL7024 opaque "GRAPHITE  
GREY"



260,00 /



RAL7024

**RAL3000 TMA1 SOVRAPPREZZO TESTATA 1 LATO SERIE  
60/70/90 VERNICIATA RAL3000 OPACO  
"ROSSO FUOCO"**  
EN EXTRA COST for lateral finish panel 1 side of  
60/70/90 series painted RAL3000 opaque "FLAME  
RED"



260,00 /



RAL3000

**RAL2004 TMA1 SOVRAPPREZZO TESTATA 1 LATO SERIE  
60/70/90 VERNICIATA RAL2004 OPACO  
"ARANCIO PURO"**  
EN EXTRA COST for lateral finish panel 1 side of  
60/70/90 series painted RAL2004 opaque "PURE  
ORANGE"



260,00 /



RAL2004

PAINT  
COLORE



Le immagini presentate non sono vincolanti. La ditta si riserva di apportare modifiche senza preavviso. • The pictures are purely representative. The manufacturer reserves the right to modify the technical data and models without previous notice. • Les images

LO

présentées ne nous engagent pas. La Société se réserve le droit d'apporter tout modification sans préavis. • Die dargestellten Abbildungen sind nicht verbindlich. Technische Änderungen vorbehalten. • Las imágenes presentadas no son vinculantes. El Fabricante se reserva el derecho de modificar sus productos sin previo aviso.

01/20

7



# COLORE 60-70-90

MOD. \_\_\_\_\_  
COD. \_\_\_\_\_

DESCRIZIONE/DESCRIPTION/BEZEICHNUNG/DESCRIPTION/DESCRIPCIÓN  
DIMENSIONI/DIMENSIONS/ABMESSUNGEN/DIMENSIONS/DIMENSIONES

POTENZA/POWER/LEISTUNG/PUISSANCE/POTENCIA  
VOLTAGGIO/VOLTAGE/SPANNUNG/VOLTAGE/VOLTAJE

⚡ kW kcal/h  
⚡ kw V~ Hz

PREZZO/PRICE €  
PREIS/PRIX/PRECIO €  
KG / M<sup>3</sup>

**RAL5015 TMA1 SOVRAPPREZZO TESTATA 1 LATO SERIE 60/70/90 VERNICIATA RAL5015 OPACO "BLU CIELO"**  
EN EXTRA COST for lateral finish panel 1 side of 60/70/90 series painted RAL5015 opaque "SKY BLUE"



260,00 /



RAL 5015

**RAL EXTRA TMA1 SOVRAPPREZZO TESTATA 1 LATO SERIE 60/70/90 VERNICIATA RAL A SCELTA FUORI LISTINO**  
EN EXTRA COST for lateral finish panel 1 side of 60/70/90 series painted RAL extra price list



290,00 /

**RAL9005 TMA2 SOVRAPPREZZO TESTATA 2 LATI SERIE 60/70/90 VERNICIATA RAL9005 OPACO "NERO INTENSO"**  
EN EXTRA COST for lateral finish panel 2 sides of 60/70/90 series painted RAL9005 opaque "JET BLACK"



390,00 /

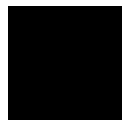

RAL9005

**RAL9016 TMA2 SOVRAPPREZZO TESTATA 2 LATI SERIE 60/70/90 VERNICIATA RAL9016 OPACO "BIANCO TRAFFICO"**  
EN EXTRA COST for lateral finish panel 2 sides of 60/70/90 series painted RAL9016 opaque "TRAFFIC WHITE"



390,00 /

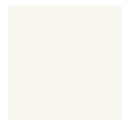

RAL9016

**RAL7024 TMA2 SOVRAPPREZZO TESTATA 2 LATI SERIE 60/70/90 VERNICIATA RAL7024 OPACO "GRIGIO GRAFITE"**  
EN EXTRA COST for lateral finish panel 2 sides of 60/70/90 series painted RAL7024 opaque "GRAPHITE GREY"



460,00 /



RAL7024

**RAL3000 TMA2 SOVRAPPREZZO TESTATA 2 LATI SERIE 60/70/90 VERNICIATA RAL3000 OPACO "ROSSO FUOCO"**  
EN EXTRA COST for lateral finish panel 2 sides of 60/70/90 series painted RAL3000 opaque "FLAME RED"



460,00 /



RAL3000

# COLORE 60-70-90

MOD. \_\_\_\_\_  
COD. \_\_\_\_\_

DESCRIZIONE/DESCRIPTION/BEZEICHNUNG/DESCRIPTION/DESCRIPCIÓN  
DIMENSIONI/DIMENSIONS/ABMESSUNGEN/DIMENSIONS/DIMENSIONES

POTENZA/POWER/LEISTUNG/PUISSANCE/POTENCIA  
VOLTAGGIO/VOLTAGE/SPANNUNG/VOLTAGE/VOLTAJE

$\frac{kW}{kcal/h}$   $\frac{V}{Hz}$

PREZZO/PRICE €  
PREIS/PRIX/PRECIO €  
KG / M<sup>3</sup>

**RAL2004 TMA2 SOVRAPPREZZO TESTATA 2 LATI SERIE 60/70/90 VERNICIATA RAL2004 OPACO "ARANCIO PURO"**  
EN EXTRA COST for lateral finish panel 2 sides of 60/70/90 series painted RAL2004 opaque "PURE ORANGE"



460,00 /



RAL2004

**RAL5015 TMA2 SOVRAPPREZZO TESTATA 2 LATI SERIE 60/70/90 VERNICIATA RAL5015 OPACO "BLU CIELO"**  
EN EXTRA COST for lateral finish panel 2 sides of 60/70/90 series painted RAL5015 opaque "SKY BLUE"



460,00 /



RAL 5015

**RAL EXTRA TMA2 SOVRAPPREZZO TESTATA 2 LATI SERIE 60/70/90 VERNICIATA RAL A SCELTA FUORI LISTINO**  
EN EXTRA COST for lateral finish panel 2 sides of 60/70/90 series painted RAL extra price list



520,00 /

**RAL9005 SA SOVRAPPREZZO SCHIENA POSTERIORE A VISTA SERIE 60/70/90 VERNICIATA RAL9005 OPACO "NERO INTENSO"**  
EN EXTRA COST for back cover of 60/70/90 series painted RAL9005 opaque "JET BLACK"  
€/m



220,00 /



RAL9005

**RAL9016 SA SOVRAPPREZZO SCHIENA POSTERIORE A VISTA SERIE 60/70/90 VERNICIATA RAL9016 OPACO "BIANCO TRAFFICO"**  
EN EXTRA COST for back cover of 60/70/90 series painted RAL9016 opaque "TRAFFIC WHITE"  
€/m



220,00 /

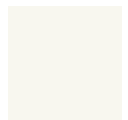

RAL9016

**RAL7024 SA SOVRAPPREZZO SCHIENA POSTERIORE A VISTA SERIE 60/70/90 VERNICIATA RAL7024 OPACO "GRIGIO GRAFITE"**  
EN EXTRA COST for back cover of 60/70/90 series painted RAL7024 opaque "GRAPHITE GREY"  
€/m



260,00 /



RAL7024

PAINT  
COLORE

# COLORE 60-70-90

MOD. \_\_\_\_\_  
COD. \_\_\_\_\_

DESCRIZIONE/DESCRIPTION/BEZEICHNUNG/DESCRIPTION/DESCRIPCIÓN  
DIMENSIONI/DIMENSIONS/ABMESSUNGEN/DIMENSIONS/DIMENSIONES

POTENZA/POWER/LEISTUNG/PUISSANCE/POTENCIA  
VOLTAGGIO/VOLTAGE/SPANNUNG/VOLTAGE/VOLTAJE

$\frac{kW}{kcal/h}$   $\frac{V}{Hz}$

PREZZO/PRICE €  
PREIS/PRIX/PRECIO €  
KG / M<sup>3</sup>

**RAL3000 SA SOVRAPPREZZO SCHIENA POSTERIORE A VISTA SERIE 60/70/90 VERNICIATA RAL3000 OPACO "ROSSO FUOCO"**  
EN EXTRA COST for back cover of 60/70/90 series painted RAL3000 opaque "FLAME RED"  
€/m



260,00 /



RAL3000

**RAL2004 SA SOVRAPPREZZO SCHIENA POSTERIORE A VISTA SERIE 60/70/90 VERNICIATA RAL2004 OPACO "ARANCIO PURO"**  
EN EXTRA COST for back cover of 60/70/90 series painted RAL2004 opaque "PURE ORANGE"  
€/m



260,00 /



RAL2004

**RAL5015 SA SOVRAPPREZZO SCHIENA POSTERIORE A VISTA SERIE 60/70/90 VERNICIATA RAL5015 OPACO "BLU CIELO"**  
EN EXTRA COST for back cover of 60/70/90 series painted RAL5015 opaque "SKY BLUE"  
€/m



260,00 /



RAL 5015

**RAL EXTRA SA SOVRAPPREZZO SCHIENA POSTERIORE A VISTA SERIE 60/70/90 VERNICIATA RAL A SCELTA FUORI LISTINO**  
EN EXTRA COST for back cover of 60/70/90 series painted RAL extra price list  
€/m



290,00 /

1985



Le immagini presentate non sono vincolanti. La ditta si riserva di apportare modifiche senza preavviso. • The pictures are purely representative. The manufacturer reserves the right to modify the technical data and models without previous notice. • Les images

LO

présentées ne nous engagent pas. La Société se réserve le droit d'apporter tout modification sans préavis. • Die dargestellten Abbildungen sind nicht verbindlich. Technische Änderungen vorbehalten. • Las imágenes presentadas no son vinculantes. El Fabricante se reserva el derecho de modificar sus productos sin previo aviso.

MOD. \_\_\_\_\_  
COD. \_\_\_\_\_

DESCRIZIONE/DESCRIPTION/BEZEICHNUNG/DESCRIPTION/DESCRIPCIÓN  
DIMENSIONI/DIMENSIONS/ABMESSUNGEN/DIMENSIONS/DIMENSIONES

POTENZA/POWER/LEISTUNG/PUISSANCE/POTENCIA  
VOLTAGGIO/VOLTAGE/SPANNUNG/VOLTAGE/VOLTAJE

⚡ kW \_\_\_\_\_  
kcal/h \_\_\_\_\_  
V~ \_\_\_\_\_  
Hz \_\_\_\_\_

PREZZO/PRICE €  
PREIS/PRIX/PRECIO €  
KG / M<sup>3</sup>

**PL-1**  
05013000  
**PIANO LAVORO**  
**EN** Worktop • **DE** Arbeitsplatte • **FR** Plan de travail  
• **ES** Sobre de trabajo  
**cm. 30x 50x 29h**



**273,00**  
8 / 0,07

**PL-2**  
05016000  
**cm. 60x 50x 29h**

**358,00**  
13 / 0,14

**LA**  
05026000  
**LAVELLO VASCA CM 34X40X17H**  
**EN** Sink unit - Bowl cm 34x40x17h • **DE** Spülbecken  
- Becken cm 34x40x17h • **FR** Bac-évier - Bac cm  
34x40x17h • **ES** Fregadero - Cuba cm 34x40x17h  
**cm. 60x 50x 29h**

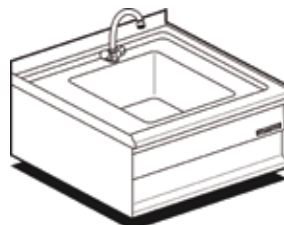

**612,00**  
12 / 0,14

**PC-1EM**  
05033010  
**PIANO COTTURA ELETTRICO 2 PIASTRE**  
**EN** Electric Cooking top nr.2 plates • **DE** Kochplatte  
elektrische - N. 2 Kochplatten • **FR** Rechaud électriques  
- N. 2 plaques • **ES** Sobre de cocción eléctrico N. 2  
planchas  
**cm. 30x 50x 29h**



⚡ 2,5 kW \_\_\_\_\_ **561,00**  
230V~ \_\_\_\_\_ 11 / 0,07  
50/60 Hz

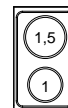

**PC-2EM**  
05036010  
**PIANO COTTURA ELETTRICO 4 PIASTRE**  
**EN** Electric Cooking top nr.4 plates • **DE** Kochplatte  
elektrische - N. 4 Kochplatten • **FR** Rechaud électriques  
- N. 4 plaques • **ES** Sobre de cocción eléctrico N. 4  
planchas  
**cm. 60x 50x 29h**



⚡ 5 kW \_\_\_\_\_ **926,00**  
230V~ \_\_\_\_\_ 17 / 0,14  
50/60 Hz

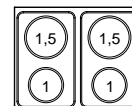

**PC-2ET**  
05036030  
**cm. 60x 50x 29h**

⚡ 5 kW \_\_\_\_\_ **939,00**  
400V~3N \_\_\_\_\_ 17 / 0,14  
230V~3 \_\_\_\_\_  
50/60 Hz

**RI-1EM**  
05043110  
**RISCALDANTE INFRAROSSO ELETTRICO**  
**EN** Electric Infrared heater • **DE** Infrarot-Strahler  
elektrische • **FR** Lampe chauffante a infra-rouge  
électriques • **ES** Calentador a infrarrojos eléctrico  
**cm. 29x 46x 37h**



⚡ 0,32 kW \_\_\_\_\_ **374,00**  
230V~ \_\_\_\_\_ 7 / 0,09  
50/60 Hz

**BS-1EM**  
05043010  
**CONTENITORE CALDO ELETTRICO VASCA GN 1/2 CM.15H CON FALSOFONDO FORATO**  
**EN** Electric Fry dump - Basin GN 1/2 15h with  
perforated double bottom • **DE** Frittenwanne elektrische  
- Becken GN 1/2 15h mit gelochtem Bodenrost • **FR**  
Silo a frites électriques - Cuve GN 1/2 15h avec double-  
fond perforé • **ES** Recipiente caliente eléctrico - Cuba  
GN 1/2 15h confalso fondo agujereado  
**cm. 30x 50x 29h**

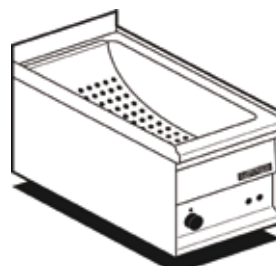

⚡ 0,83 kW \_\_\_\_\_ **624,00**  
230V~ \_\_\_\_\_ 10 / 0,07  
50/60 Hz



# BAGNOMARIA ELETTRICI

MOD. \_\_\_\_\_  
COD. \_\_\_\_\_

DESCRIZIONE/DESCRIPTION/BEZEICHNUNG/DESCRIPTION/DESCRIPCIÓN  
DIMENSIONI/DIMENSIONS/ABMESSUNGEN/DIMENSIONS/DIMENSIONES

POTENZA/POWER/LEISTUNG/PUISSANCE/POTENCIA  
VOLTAGGIO/VOLTAGE/SPANNUNG/VOLTAGE/VOLTAJE

⚡ kW \_\_\_\_\_  
kcal/h \_\_\_\_\_  
V~ \_\_\_\_\_  
Hz \_\_\_\_\_

PREZZO/PRICE € \_\_\_\_\_  
PREIS/PRIX/PRECIO € \_\_\_\_\_  
KG / M<sup>3</sup> \_\_\_\_\_

**BM-1EM**  
05053010

**BAGNOMARIA ELETTRICO VASCA PER GN 1/2 CM.15H**

**EN** Electric Bain-marie - Bowl for GN 1/2 cm.15h • **DE** Wasserbad elektrische - Becken für GN 1/2 cm.15h  
• **FR** Bain-marie électriques - Cuve pour GN 1/2 cm.15h • **ES** Baño de maría eléctrico - Cuba para GN 1/2 cm.15h

**cm. 30x 50x 29h**



⚡ 0,83 kW \_\_\_\_\_ **829,00**  
230V~ \_\_\_\_\_ 10 / 0,07  
50/60 Hz \_\_\_\_\_

**BM-2EM**  
05056010

**BAGNOMARIA ELETTRICO VASCA PER GN 1/1 CM.15H**

**EN** Electric Bain-marie - Bowl for GN 1/1 cm.15h • **DE** Wasserbad elektrische - Becken für GN 1/1 cm.15h  
• **FR** Bain-marie électriques - Cuve pour GN 1/1 cm.15h • **ES** Baño de maría eléctrico - Cuba para GN 1/1 cm.15h

**cm. 60x 50x 29h**

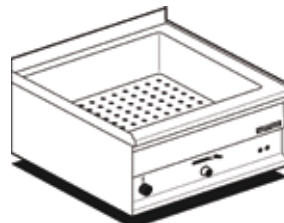

⚡ 1,66 kW \_\_\_\_\_ **834,00**  
230V~ \_\_\_\_\_ 14 / 0,14  
50/60 Hz \_\_\_\_\_

**FTL-1EM**  
05063011

**FRY-TOP ELETTRICO LISCIO, PIASTRA CM.27X41**

**EN** Electric Fry-top smooth griddle, plate cm. 27x41  
• **DE** Griddleplatte elektrische glatt, platte cm. 27x41  
• **FR** Plaque électriques lisse, plaque cm. 27x41 • **ES** Fry-top eléctrico liso, plancha cm. 27x41

**cm. 30x 50x 29h**



⚡ 2,66 kW \_\_\_\_\_ **781,00**  
230V~ \_\_\_\_\_ 23 / 0,15  
50/60 Hz \_\_\_\_\_

**FTL-1ET**  
05063031

**cm. 30x 50x 29h**

⚡ 3 kW \_\_\_\_\_ **883,00**  
400V~3N \_\_\_\_\_ 23 / 0,15  
230V~3 \_\_\_\_\_  
50/60 Hz \_\_\_\_\_

**FTL-1EMS**  
05063014

**FRY-TOP ELETTRICO LISCIO CROMATO, PIASTRA CM.27X41**

**EN** Electric Fry-top smooth chromed griddle, plate cm. 27x41 • **DE** Griddleplatte elektrische glatt hartverchromt, platte cm. 27x41 • **FR** Plaque électriques lisse chromée, plaque cm. 27x41 • **ES** Fry-top eléctrico liso cromado, plancha cm. 27x41

**cm. 30x 50x 29h**

⚡ 2,66 kW \_\_\_\_\_ **1.114,00**  
230V~ \_\_\_\_\_ 23 / 0,15  
50/60 Hz \_\_\_\_\_

**FTL-1ETS**  
05063034

**cm. 30x 50x 29h**

⚡ 3 kW \_\_\_\_\_ **1.182,00**  
400V~3N \_\_\_\_\_ 23 / 0,15  
230V~3 \_\_\_\_\_  
50/60 Hz \_\_\_\_\_

**FTR-1EM**  
05063013

**FRY-TOP ELETTRICO RIGATO, PIASTRA CM.27X41**

**EN** Electric Fry-top grooved griddle, plate cm. 27x41  
• **DE** Griddleplatte elektrische gerillt, platte cm. 27x41  
• **FR** Plaque électriques nervurée, plaque cm. 27x41  
• **ES** Fry-top eléctrico estriado, plancha cm. 27x41

**cm. 30x 50x 29h**

⚡ 2,66 kW \_\_\_\_\_ **939,00**  
230V~ \_\_\_\_\_ 23 / 0,15  
50/60 Hz \_\_\_\_\_

**FTR-1ET**  
05063033

**cm. 30x 50x 29h**

⚡ 3 kW \_\_\_\_\_ **1.040,00**  
400V~3N \_\_\_\_\_ 23 / 0,15  
230V~3 \_\_\_\_\_  
50/60 Hz \_\_\_\_\_

50



Le immagini presentate non sono vincolanti. La ditta si riserva di apportare modifiche senza preavviso. • The pictures are purely representative. The manufacturer reserves the right to modify the technical data and models without previous notice. • Les images

LO

présentées ne nous engagent pas. La Société se réserve le droit d'apporter tout modification sans préavis. • Die dargestellten Abbildungen sind nicht verbindlich. Technische Änderungen vorbehalten. • Las imágenes presentadas no son vinculantes. El Fabricante se reserva el derecho de modificar sus productos sin previo aviso.

01/20

13

# FRY-TOP ELETTRICI

MOD. \_\_\_\_\_  
COD. \_\_\_\_\_

DESCRIZIONE/DESCRIPTION/BEZEICHNUNG/DESCRIPTION/DESCRIPCIÓN  
DIMENSIONI/DIMENSIONS/ABMESSUNGEN/DIMENSIONS/DIMENSIONES

POTENZA/POWER/LEISTUNG/PUISSANCE/POTENCIA  
VOLTAGGIO/VOLTAGE/SPANNUNG/VOLTAGE/VOLTAJE

⚡ kW \_\_\_\_\_  
kcal/h \_\_\_\_\_  
V~ \_\_\_\_\_  
Hz \_\_\_\_\_

PREZZO/PRICE € \_\_\_\_\_  
PREIS/PRIX/PRECIO € \_\_\_\_\_  
KG / M<sup>3</sup> \_\_\_\_\_

**FTL-2EM**  
05066011

**FRY-TOP ELETTRICO LISCIO, PIASTRA CM.57X41**

EN Electric Fry-top smooth griddle, plate cm. 57x41  
• DE Griddleplatte elektrische glatt, platte cm. 57x41  
• FR Plaque électriques lisse, plaque cm. 57x41 • ES Fry-top eléctrico liso, plancha cm. 57x41  
**cm. 60x 50x 29h**

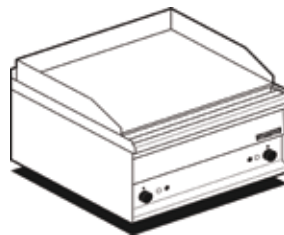

⚡ 5,32 kW \_\_\_\_\_ **1.121,00**  
230V~ \_\_\_\_\_ 40 / 0,28  
50/60 Hz \_\_\_\_\_

**FTL-2ET**  
05066031

**cm. 60x 50x 29h**

⚡ 6 kW \_\_\_\_\_ **1.308,00**  
400V~3N \_\_\_\_\_ 40 / 0,28  
230V~3 \_\_\_\_\_  
50/60 Hz \_\_\_\_\_

**FTL-2EMS**  
05066014

**FRY-TOP ELETTRICO LISCIO CROMATO, PIASTRA CM.57X41**

EN Electric Fry-top smooth chromed griddle, plate cm. 57x41 • DE Griddleplatte elektrische glatt hartverchromt, platte cm. 57x41 • FR Plaque électriques lisse chromée, plaque cm. 57x41 • ES Fry-top eléctrico liso cromado, plancha cm. 57x41  
**cm. 60x 50x 29h**

⚡ 5,32 kW \_\_\_\_\_ **1.562,00**  
230V~ \_\_\_\_\_ 40 / 0,28  
50/60 Hz \_\_\_\_\_

**FTL-2ETS**  
05066034

**cm. 60x 50x 29h**

⚡ 6 kW \_\_\_\_\_ **1.765,00**  
400V~3N \_\_\_\_\_ 40 / 0,28  
230V~3 \_\_\_\_\_  
50/60 Hz \_\_\_\_\_

**FTLR-2EM**  
05066012

**FRY-TOP ELETTRICO 1/2 LISCIO + 1/2 RIGATO, PIASTRA CM.57X41**

EN Electric Fry-top 1/2 smooth + 1/2 grooved griddle, plate cm. 57x41 • DE Griddleplatte elektrische 1/2 glatt + 1/2 gerillt, platte cm. 57x41 • FR Plaque électriques 1/2 lisse + 1/2 nervurée, plaque cm. 57x41 • ES Fry-top eléctrico 1/2 liso + 1/2 estriado, plancha cm. 57x41  
**cm. 60x 50x 29h**

⚡ 5,32 kW \_\_\_\_\_ **1.285,00**  
230V~ \_\_\_\_\_ 40 / 0,28  
50/60 Hz \_\_\_\_\_

**FTLR-2ET**  
05066032

**cm. 60x 50x 29h**

⚡ 6 kW \_\_\_\_\_ **1.470,00**  
400V~3N \_\_\_\_\_ 40 / 0,28  
230V~3 \_\_\_\_\_  
50/60 Hz \_\_\_\_\_

**FQ-1EM**  
05073010

**FRIGGITRICE ELETTRICA - VASCA LT. 8 CESTO CM. 20X27X11H - PRODUZIONE PATATE: 9 KG/H**

EN Electric fryer - Tank capacity lts. 8 Basket cm. 20x27x11h - Production: 9 Kg/hr • DE Friteuse elektrische - Beckeninhalt lt. 8 Korb cm. 20x27x11h - Pommes frites: 9 Kg/pro Stunde • FR Friteuse électrique - Cuve lt. 8 Panier cm. 20x27x11h - Production: 9 Kg/h • ES Freidora eléctrica - Cuba lt.8 Cesta cm. 20x27x11h - Producción patatas: 9 Kg/h  
**cm. 30x 50x 29h**



⚡ 3 kW \_\_\_\_\_ **815,00**  
230V~ \_\_\_\_\_ 18 / 0,15  
50/60 Hz \_\_\_\_\_

**FQ-1ET**  
05073030

**cm. 30x 50x 29h**

⚡ 5,4 kW \_\_\_\_\_ **986,00**  
400V~3N \_\_\_\_\_ 20 / 0,15  
230V~3 \_\_\_\_\_  
50/60 Hz \_\_\_\_\_

# FRIGGITRICI ELETTRICHE

MOD. \_\_\_\_\_  
COD. \_\_\_\_\_

DESCRIZIONE/DESCRIPTION/BEZEICHNUNG/DESCRIPTION/DESCRIPCIÓN  
DIMENSIONI/DIMENSIONS/ABMESSUNGEN/DIMENSIONS/DIMENSIONES

POTENZA/POWER/LEISTUNG/PUISSANCE/POTENCIA  
VOLTAGGIO/VOLTAGE/SPANNUNG/VOLTAGE/VOLTAJE

⚡ kW kcal/h  
230V~ V~  
50/60 Hz Hz

PREZZO/PRICE €  
PREIS/PRIX/PRECIO €  
KG / M<sup>3</sup>

**FQ-2EM**  
05076010

**FRIGGITRICE ELETTRICA - VASCHE LT. 8+8 N. 2 CESTI CM. 20X27X11H - PRODUZIONE PATATE: 18 KG/H**

**EN** Electric fryer - Tank capacity 8+8 lts. N. 2 Baskets cm. 20x27x11h - Production: 18 Kg/hr • **DE** Friteuse elektrische - Beckeninhalte lt. 8+8 - N. 2 Körbe cm. 20x27x11h - Pommes frites: 18 Kg/pro Stunde • **FR** Friteuse électrique - Cuve l. 8+8 N. 2 Paniers cm. 20x27x11h - Production: 18 Kg/h • **ES** Freidora eléctrica - Cuba lt. 8 + 8 2 Cestas cm. 20x27x11h - Producción patatas: 18 Kg/h  
**cm. 60x 50x 29h**

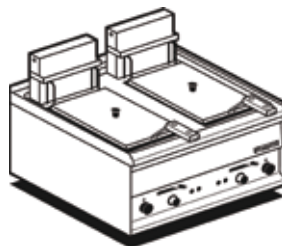

⚡ 6 kW **1.481,00**  
230V~ 33 / 0,28  
50/60 Hz

**FQ-2ET**  
05076030

**cm. 60x 50x 29h**

⚡ 10,8 kW **1.805,00**  
400V~3N 35 / 0,28  
230V~3  
50/60 Hz

**531014400 OPTIONAL: CESTO 1/2**

**EN** Optional: basket 1/2 • **DE** Zubehör: Fritierkorb 1/2 • **FR** En option: panier 1/2 • **ES** Opcional: cesta 1/2  
**cm. 10x 25x 10h**

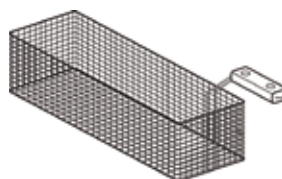

**41,00**  
0.6 / 0,03

**CP-1EM**  
05083010

**CUOCI-PASTA/VERDURE ELETTRICO - VASCA LT. 10 - N. 4 CESTINI CM. 10X14X13,5H**

**EN** Electric Pastacooker - Tank capacity 10 lts. N. 4 baskets cm. 10x14x13,5h • **DE** Nudelkocher elektrische - Beckeninhalte lt. 10 N. 4 Körbe cm. 10x14x13,5h • **FR** Cuiseur a pates/legumes électrique - Cuve l. 10 - N. 4 paniers cm. 10x14x13,5 • **ES** Cuece pastas/verduras eléctrico - Cuba lt.10 - 4 cestas cm 10x14x13,5h  
**cm. 30x 50x 29h**



⚡ 2,83 kW **873,00**  
230V~ 13 / 0,07  
50/60 Hz

**CP-2ET**  
05086030

**CUOCI-PASTA/VERDURE ELETTRICO - VASCA LT. 20 - N. 8 CESTINI CM. 10X14X13,5H**

**EN** Electric Pastacooker - Tank capacity 20 lts. - N 8 baskets cm. 10x14x13,5h • **DE** Nudelkocher elektrische - Beckeninhalte lt. 20 - N. 8 Körbe cm. 10x14x13,5h • **FR** Cuiseur a pates/legumes électrique - Cuve l. 20 - N. 8 paniers cm. 10x14x13,5 • **ES** Cuece pastas/verduras eléctrico - Cuba lt. 20 - 8 cestas cm. 10x14x13,5h  
**cm. 60x 50x 29h**

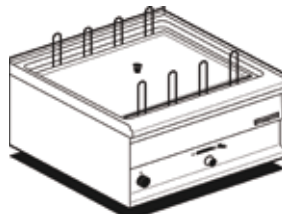

⚡ 6 kW **1.346,00**  
400V~3N 22 / 0,14  
230V~3  
50/60 Hz

**531001600 CESTINO 1/4 INOX**

**EN** Stainless steel basket 1/4 • **DE** Korb 1/4 aus Edelstahl • **FR** Panier inox 1/4 • **ES** Cesta 1/4 inox  
**cm. 10x 14x 13,5h**

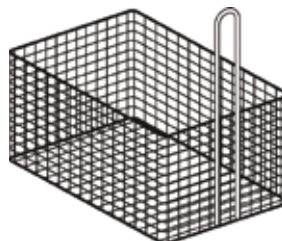

**43,00**  
/ 0,02

**531004000 CESTINO 1/2 INOX**

**EN** Stainless steel basket 1/2 • **DE** Korb 1/2 aus Edelstahl • **FR** Panier inox 1/2 • **ES** Cesta 1/2 inox  
**cm. 10x 28x 13,5h**

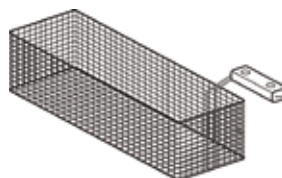

**67,00**  
/ 0,03



Le immagini presentate non sono vincolanti. La ditta si riserva di apportare modifiche senza preavviso. • The pictures are purely representative. The manufacturer reserves the right to modify the technical data and models without previous notice. • Les images

**LO**

présentées ne nous engagent pas. La Société se réserve le droit d'apporter tout modification sans préavis. • Die dargestellten Abbildungen sind nicht verbindlich. Technische Änderungen vorbehalten. • Las imágenes presentadas no son vinculantes. El Fabricante se reserva el derecho de modificar sus productos sin previo aviso.

01/20

**15**

**50**

# ACCESSORI CUOCIPASTA

MOD. \_\_\_\_\_  
COD. \_\_\_\_\_

DESCRIZIONE/DESCRIPTION/BEZEICHNUNG/DESCRIPTION/DESCRIPCIÓN  
DIMENSIONI/DIMENSIONS/ABMESSUNGEN/DIMENSIONS/DIMENSIONES

POTENZA/POWER/LEISTUNG/PUISSANCE/POTENCIA  
VOLTAGGIO/VOLTAGE/SPANNUNG/VOLTAGE/VOLTAJE

⚡ kW kcal/h  
⚡ kw V~ Hz

PREZZO/PRICE €  
PREIS/PRIX/PRECIO €  
KG / M<sup>3</sup>

**531003900 CESTINO 1/1 INOX**  
EN Stainless steel basket 1/1 • DE Korb 1/1 aus  
Edelstahl • FR Panier inox 1/1 • ES Cesta 1/1 inox  
cm. 20x 28x 13,5h



**87,00**  
/ 0,04

**S-3**  
05210300 **CAVALLETTO BASE**  
EN Stand • DE Untergestell • FR Pietement simple  
• ES Soporte base  
cm. 30x 40x 60h

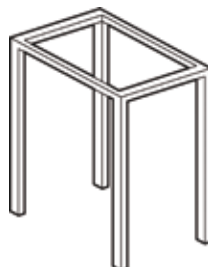

**177,00**  
2 / 0,12

**S-6**  
05210600 cm. 60x 40x 60h

**194,00**  
3 / 0,22

**M-3**  
05220300 **MOBILE BASE**  
EN Stand • DE Offener Unterbau • FR Placard ouvert  
• ES Mueble base  
cm. 30x 40x 60h

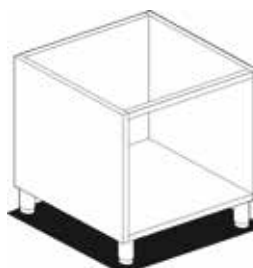

**329,00**  
9 / 0,09

**M-6**  
05220600 cm. 60x 40x 60h

**358,00**  
12 / 0,16

**M-9**  
05220900 cm. 90x 40x 60h

**418,00**  
16 / 0,23

**M-12**  
05221200 cm. 120x 40x 60h

**482,00**  
19 / 0,30

**R-3**  
05240300 **RIPIANO**  
EN Shelf • DE Abstellbrett • FR Etagère • ES Estante  
cm. 26x 39,5x 3h



**85,00**  
1 / 0,01

**R-6**  
05240600 cm. 56x 39,5x 3h

**106,00**  
2 / 0,01

**P-61**  
06256000 **PORTA**  
EN Door • DE Flügeltür • FR Porte • ES Puerta  
cm. 29,5x 2,5x 47h



**146,00**  
2.5 / 0,01

**CG-5**  
05264800 **COPRIGIUNTO**  
EN Joint cover • DE Klemmsteg • FR Couvre-joint  
• ES Cubre junta  
cm. 48,5x 0,7x 1,5h

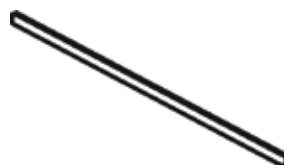

**24,00**  
0.1 / 1,00

# ACCESSORI

MOD. COD.	DESCRIZIONE/DESCRIPTION/BEZEICHNUNG/DESCRIPTION/DESCRIPCIÓN DIMENSIONI/DIMENSIONS/ABMESSUNGEN/DIMENSIONS/DIMENSIONES	POTENZA/POWER/LEISTUNG/PUISSANCE/POTENCIA VOLTAGGIO/VOLTAGE/SPANNUNG/VOLTAGE/VOLTAJE	$\frac{kW}{kcal/h}$ $\frac{V\sim}{Hz}$	PREZZO/PRICE € PREIS/PRIX/PRECIO € KG / M <sup>3</sup>
<b>TG-1</b> 05270300	<b>TAGLIERE</b> <b>EN</b> Chopping board • <b>DE</b> Schneidebrett • <b>FR</b> Plan a découpe • <b>ES</b> Picador <b>cm. 29x 48,5x 2,5h</b>			<b>98,00</b> 4 / 0,01
<b>TG-2</b> 05270600	<b>cm. 59x 48,5x 2,5h</b>			<b>173,00</b> 8 / 0,01

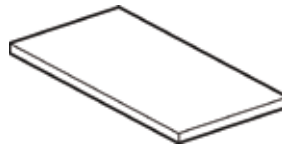







**55**



Le immagini presentate non sono vincolanti. La ditta si riserva di apportare modifiche senza preavviso. • The pictures are purely representative. The manufacturer reserves the right to modify the technical data and models without previous notice. • Les images

**LO**

présentées ne nous engagent pas. La Société se réserve le droit d'apporter toute modification sans préavis. • Die dargestellten Abbildungen sind nicht verbindlich. Technische Änderungen vorbehalten. • Las imágenes presentadas no son vinculantes. El Fabricante se reserva el derecho de modificar sus productos sin previo aviso.

MOD. \_\_\_\_\_  
COD. \_\_\_\_\_

DESCRIZIONE/DESCRIPTION/BEZEICHNUNG/DESCRIPTION/DESCRIPCIÓN  
DIMENSIONI/DIMENSIONS/ABMESSUNGEN/DIMENSIONS/DIMENSIONES

POTENZA/POWER/LEISTUNG/PUISSANCE/POTENCIA  
VOLTAGGIO/VOLTAGE/SPANNUNG/VOLTAGE/VOLTAJE

⚡ kW kcal/h ⚡ kW kcal/h  
V~ Hz PREZZO/PRICE €  
PREIS/PRIX/PRECIO €  
KG / M<sup>3</sup>

**CF2-58G**  
15120850

**CUCINETTA 2 FUOCHI - FORNO GAS  
STATICO CON GRILL CM. 67X38X34H, TEMP:  
50÷250°C, CON 1 GRIGLIA CM.65X36**

**EN** Gas range - N. 2 burners Gas static oven with grill cm. 67x38x34h, temp: 50÷250°C, with 1 grid cm.65x36 • **DE** Gashernd - N. 2 Kochstellen Statischer Gas-Backofen mit Grill cm. 67x38x34h, temp: 50÷250°C, mit 1 Rost cm.65x36 • **FR** Cuisinière à gaz - N. 2 feux vifs Four gaz statique avec grill cm. 67x38x34h, temp: 50÷250°C, avec 1 grille cm.65x36 • **ES** Cocina a gas - N. 2 quemadores Horno gas estático con asador cm. 67x38x34h, temp: 50÷250°C, con 1 parilla cm.65x36  
**cm. 80x 55x 90h**



⚡ 21 kW 2.391,00  
18.060 kcal/h 122 / 0,61

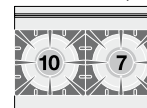

**CF2-58GE**  
15130860

**CUCINETTA 2 FUOCHI - FORNO ELETTRICO  
STATICO CON GRILL CM. 67X38X34H, TEMP:  
50÷250°C, CON 1 GRIGLIA CM.65X36**

**EN** Gas range - N. 2 burners Electric static oven with grill cm. 67x38x34h, temp: 50÷250°C, with 1 grid cm.65x36 • **DE** Gashernd - N. 2 Kochstellen - Statischer Elektro-Backofen mit Grill cm. 67x38x34h, temp: 50÷250°C, mit 1 Rost cm.65x36 • **FR** Cuisinière à gaz - N. 2 feux vifs - Four électrique statique avec grill cm. 67x38x34h, temp: 50÷250°C, avec 1 grille cm.65x36 • **ES** Cocina a gas - N. 2 quemadores - Horno eléctrico estático con asador cm. 67x38x34h, temp: 50÷250°C, con 1 parilla cm.65x36  
**cm. 80x 55x 90h**



⚡ 17 kW 2.391,00  
14.620 kcal/h 120 / 0,61

⚡ 3,05 kW  
230V~  
50/60 Hz

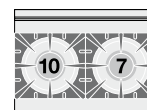

**CF3-512GV**  
15121251

**CUCINETTA 3 FUOCHI - FORNO GAS  
STATICO CON GRILL CM. 67X38X34H, TEMP:  
50÷250°C, CON 1 GRIGLIA CM.65X36. VANO  
NEUTRO CON PORTA**

**EN** Gas range - N. 3 burners - Gas static oven with grill cm. 67x38x34h, temp: 50÷250°C, with 1 grid cm.65x36 - Neutral cabinet with door • **DE** Gashernd - N. 3 Kochstellen - Statischer Gas-Backofen mit Grill cm. 67x38x34h, temp: 50÷250°C, mit 1 Rost cm.65x36 - Neutrales Schrankelement mit Tür • **FR** Cuisinière gaz - N. 3 feux vifs - Four gaz statique avec grill cm. 67x38x34h, temp: 50÷250°C, avec 1 grille cm.65x36 - Élément neutre avec porte • **ES** Cocina a gas - N. 3 quemadores - Horno gas estático con asador cm. 67x38x34h, temp: 50÷250°C, con 1 parilla cm.65x36 - Armario neutro con puerta  
**cm. 120x 55x 90h**



⚡ 31 kW 2.981,00  
26.660 kcal/h 150 / 0,91

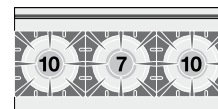

**CF3-512GEV**  
15131261

**CUCINETTA 3 FUOCHI - FORNO ELETTRICO  
STATICO CON GRILL CM. 67X38X34H, TEMP:  
50÷250°C, CON 1 GRIGLIA CM.65X36. VANO  
NEUTRO CON PORTA**

**EN** Gas range - N. 3 burners - Electric static oven with grill cm. 67x38x34h, temp: 50÷250°C, with 1 grid cm.65x36 - Neutral cabinet with door • **DE** Gashernd - N. 3 Kochstellen - Statischer Elektro-Backofen mit Grill cm. 67x38x34h, temp: 50÷250°C, mit 1 Rost cm.65x36 - Neutrales Schrankelement mit Tür • **FR** Cuisinière gaz - N. 3 feux vifs - Four électrique statique avec grill cm. 67x38x34h, temp: 50÷250°C, avec 1 grille cm.65x36 - Élément neutre avec porte • **ES** Cocina a gas - N. 3 quemadores - Horno eléctrico estático con asador cm. 67x38x34h, temp: 50÷250°C, con 1 parilla cm.65x36 - Armario neutro con puerta  
**cm. 120x 55x 90h**



⚡ 27 kW 2.981,00  
23.220 kcal/h 148 / 0,91

⚡ 3,05 kW  
230V~  
50/60 Hz

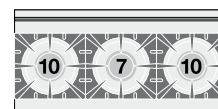

MOD. \_\_\_\_\_  
COD. \_\_\_\_\_

DESCRIZIONE/DESCRIPTION/BEZEICHNUNG/DESCRIPTION/DESCRIPCIÓN  
DIMENSIONI/DIMENSIONS/ABMESSUNGEN/DIMENSIONS/DIMENSIONES

POTENZA/POWER/LEISTUNG/PUISSANCE/POTENCIA  
VOLTAGGIO/VOLTAGE/SPANNUNG/VOLTAGE/VOLTAJE

⚡ kW kcal/h  
⚡ kW V~ Hz

PREZZO/PRICE €  
PREIS/PRIX/PRECIO €  
KG / M<sup>3</sup>

**KIT-WOK**  
09580040

**KIT WOK - FIAMMA VERTICALE - SOLO SU BRUCIATORE DA 10 KW E GRIGLIE IN GHISA**  
**EN** KIT WOK - vertical flame - only for 10 kW burner and cast iron grills • **DE** KIT WOK - vertikaler Flamme - nur 10 kW-Brenner und Roste aus Gusseisen • **FR** KIT WOK - verticale de la flamme - seulement 10 kW brûleur et grilles en fonte • **ES** KIT WOK - llama vertical - sólo 10 kW quemador y parrilas de hierro colado  
**cm. Ø 26x 16h**



**337,00**  
5 / 0,02







60

# BAGNOMARIA ELETTRICI - TOP

MOD. \_\_\_\_\_  
COD. \_\_\_\_\_

DESCRIZIONE/DESCRIPTION/BEZEICHNUNG/DESCRIPTION/DESCRIPCIÓN  
DIMENSIONI/DIMENSIONS/ABMESSUNGEN/DIMENSIONS/DIMENSIONES

POTENZA/POWER/LEISTUNG/PUISSANCE/POTENCIA  
VOLTAGGIO/VOLTAGE/SPANNUNG/VOLTAGE/VOLTAJE

⚡ kW  
kcal/h

⚡ kW  
V~  
Hz

PREZZO/PRICE €  
PREIS/PRIX/PRECIO €  
KG / M<sup>3</sup>

**BMT-63EM**  
16050310

**BAGNOMARIA ELETTRICO MONOFASE VASCA PER GN 1/2 + GN 1/4 H=15**

EN Bain marie singlephase Bowl for GN 1/2 + GN 1/4 h=15 • DE Wasserbäder einphasig Becken GN 1/2 + GN 1/4 h=15 • FR Bain marie monophasé Cuve GN 1/2 + GN 1/4 h=15 • ES Baño de maría monofásico Cuba para GN 1/2 + GN 1/4 h=15  
cm. 30x 60x 28h



⚡ 1,55 kW  
230V~  
50/60 Hz

**733,00**  
17 / 0,14

**BMT-64EM**  
16050410

**BAGNOMARIA ELETTRICO MONOFASE VASCA PER GN 1/2 + GN 1/3 H=15**

EN Bain marie singlephase Bowl for GN 1/2 + GN 1/3 h=15 • DE Wasserbäder einphasig Becken GN 1/2 + GN 1/3 h=15 • FR Bain marie monophasé Cuve GN 1/2 + GN 1/3 h=15 • ES Baño de maría monofásico Cuba para GN 1/2 + GN 1/3 h=15  
cm. 40x 60x 28h

⚡ 1,65 kW  
230V~  
50/60 Hz

**854,00**  
21 / 0,18

**BMT-66EM**  
16050610

**BAGNOMARIA ELETTRICO MONOFASE VASCA PER GN 1/1 + 2 GN 1/4 H=15**

EN Bain marie singlephase Bowl for GN 1/1 + 2 GN 1/4 h=15 • DE Wasserbäder einphasig Becken GN 1/1 + 2 GN 1/4 h=15 • FR Bain marie monophasé Cuve GN 1/1 + 2 GN 1/4 h=15 • ES Baño de maría monofásico Cuba para GN 1/1 + 2 GN 1/4 h=15  
cm. 60x 60x 28h

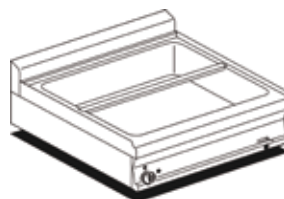

⚡ 3,1 kW  
230V~  
50/60 Hz

**946,00**  
23 / 0,27

**BMT-64G**  
16220450

**BAGNOMARIA A GAS VASCA PER GN 1/2 + GN 1/3 H=15**

EN Gas bain-marie Bowl for GN 1/2 + GN 1/3 h=15 • DE Gas Wasserbad Becken GN 1/2 + GN 1/3 h=15 • FR Bain-marie gaz Cuve pour GN 1/2 + GN 1/3 h=15 • ES Baño de maría gas Cuba para GN 1/2 + GN 1/3 h=15  
cm. 40x 60x 28h

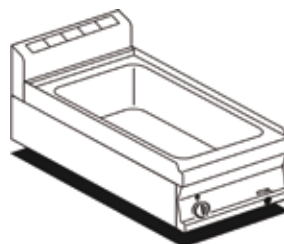

⚡ 2,5 kW  
2.150 kcal/h

**1.169,00**  
26 / 0,18

**BMT-66G**  
16220650

**BAGNOMARIA A GAS VASCA PER GN 1/1 + 2 GN 1/4 H=15**

EN Gas bain-marie Bowl for GN 1/1 + 2 GN 1/4 h=15 • DE Gas Wasserbad Becken GN 1/1 + 2 GN 1/4 h=15 • FR Bain-marie gaz Cuve pour GN 1/1 + 2 GN 1/4 h=15 • ES Baño de maría gas Cuba para GN 1/1 + 2 GN 1/4 h=15  
cm. 60x 60x 28h



⚡ 4,5 kW  
3.870 kcal/h

**1.415,00**  
28 / 0,27

**BST-64EM**  
16040410

**CONTENITORE CALDO MONOFASE VASCA GN 2/3 H15 CON FALSO FONDO FORATO**

EN Fry dump singlephase Bowl GN 2/3 h15 with perforated bottom • DE Frittenwanne einphasig Becke GN 2/3 h15 mit gelochtem Bodenrost • FR Silo à frites monophasé Cuve GN 2/3 h15 avec double-fond perforé • ES Recipiente caliente monofásico Cuba GN 2/3 h15 con falso fondo agujereado  
cm. 40x 60x 28h



⚡ 1,47 kW  
230V~  
50/60 Hz

**1.059,00**  
22 / 0,18

**BRF-64ET**  
06070433

**BRASIERA FISSA MULTIFUNZIONALE ELETTRICA - LT.12 VASCA CM. 30X42X10H**

EN Electric multi-function fixed braising pan - lt.12 Bowl cm. 30x42x10h • DE Elektrische Multifunktionsbratpfanne Fest - lt.12 Becken cm. 30x42x10h • FR Sauteuse fixe multifonction électrique - lt.12 Cuve cm. 30x42x10h • ES Sarten fija multifunción eléctrica Cuba - lt.12 cm. 30x42x10h  
cm. 40x 60x 90h



⚡ 3,3 kW  
400V~3N  
230V~3  
50/60 Hz

**2.672,00**  
75 / 0,32

# BRASIERE FISSE MULTIFUNZIONE A GAS

MOD. \_\_\_\_\_  
COD. \_\_\_\_\_

DESCRIZIONE/DESCRIPTION/BEZEICHNUNG/DESCRIPTION/DESCRIPCIÓN  
DIMENSIONI/DIMENSIONS/ABMESSUNGEN/DIMENSIONS/DIMENSIONES

POTENZA/POWER/LEISTUNG/PUISSANCE/POTENCIA  
VOLTAGGIO/VOLTAGE/SPANNUNG/VOLTAGE/VOLTAJE

6 kW  
5.160 kcal/h

PREZZO/PRICE €  
PREIS/PRIX/PRECIO €  
KG / M<sup>3</sup>

**BRF-64G**  
06240453

## BRASIERA FISSA MULTIFUNZIONALE GAS- LT.12 VASCA 30X42X10H

**EN** Gas multi-function fixed braising pan - Lt.12 Bowl 30x42x10h • **DE** Gas-Multifunktionsbratpfanne Fest - Lt.12 Becken 30x42x10h • **FR** Sauteuse fixe multifonction à gaz - Lt.12 Cuve 30x42x10h • **ES** Sartén fija multifunción a gas Cuba - Lt.12 30x42x10h  
**cm. 40x 60x 90h**



6 kW  
5.160 kcal/h

**2.842,00**  
75 / 0,32

**BRT-66ET**  
16070630

## BRASIERA TRIFASE - LT. 20 VASCA CM. 50,5X41X10H

**EN** Bratt-pan threephase - Tank capacity 20 lts. - Pan cm. 50,5x41x10 h • **DE** Bratpfanne dreiphasig - Lt. 20 - Becken cm. 50,5x41x10 h • **FR** Sauteuse triphase - Lt. 20 - Bac cm. 50,5x41x10h • **ES** Sartén trifásica - 20 Lt. - Cuba cm. 50,5x41x10h  
**cm. 60x 60x 28h**



6 kW  
400V~3N  
230V~3  
50/60 Hz

**1.384,00**  
45 / 0,27

**BRF-66G**  
16240650

## BRASIERA GAS - LT. 20 VASCA CM. 50,5X41X10H

**EN** Gas bratt-pan - Capacity 20 litres - Pan cm. 50,5x41x10 h • **DE** Gas Bratpfanne - Lt. 20 - Becken cm. 50,5x41x10 h • **FR** Sauteuse gaz - Lt. 20 - Bac cm. 50,5x41x10h • **ES** Sartén gas - 20 l. - Cuba cm. 50,5x41x10h  
**cm. 60x 60x 28h**



6,9 kW  
5.930 kcal/h

**1.842,00**  
46 / 0,27

**CF4-68G**  
06680850

## CUCINA A GAS 4 FUOCHI FORNO A GAS STATICO CON GRILL CM. 64X39X35H, TEMP: 125÷275°C, CON 1 GRIGLIA CM.53X32,5 GN1/1 - PORTA VETRO

**EN** Gas range - N. 4 burners - Gas static oven with grill cm. 64x39x35h, temp: 125÷275°C, with 1 grid cm.53x32,5 GN1/1 - glass door • **DE** Gasherd - N. 4 Kochstellen - Gas Statischer Backofen mit grill cm. 64x39x35h, temp: 125÷275°C, mit 1 Rost cm.53x32,5 GN1/1 - Glastür • **FR** Cuisinière gaz - N. 4 feux vifs - Four gaz statique avec grill cm. 64x39x35h, temp: 125÷275°C, avec 1 grille cm.53x32,5 GN1/1 - Porte vitrée • **ES** Cocina gas - N. 4 quemadores - Horno gas estático con asador cm. 64x39x35h, temp: 125÷275°C, con 1 parilla cm.53x32,5 GN1/1 - Puerta vidrio  
**cm. 80x 60x 90h**



22 kW  
18.920 kcal/h

**2.729,00**  
97 / 0,62

0,015 kW  
230V~  
50/60 Hz

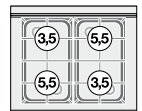

**CF4-68G**  
06680851

## CUCINA A GAS 4 FUOCHI FORNO A GAS STATICO CON GRILL CM. 64X39X35H, TEMP: 125÷275°C, CON 1 GRIGLIA CM.53X32,5 GN1/1 - PORTA CIECA INOX

**EN** Gas range - N. 4 burners - Gas static oven with grill cm. 64x39x35h, temp: 125÷275°C, with 1 grid cm.53x32,5 GN1/1 - Stainless steel door • **DE** Gasherd - N. 4 Kochstellen - Gas Statischer Backofen mit grill cm. 64x39x35h, temp: 125÷275°C, mit 1 Rost cm.53x32,5 GN1/1 - Edelstahltür/Porte acier inoxydable • **FR** Cuisinière gaz - N. 4 feux vifs - Four gaz statique avec grill cm. 64x39x35h, temp: 125÷275°C, avec 1 grille cm.53x32,5 GN1/1 - Porte acier inoxydable • **ES** Cocina gas - N. 4 quemadores - Horno gas estático con asador cm. 64x39x35h, temp: 125÷275°C, con 1 parilla cm.53x32,5 GN1/1 - Puerta ciega inox  
**cm. 80x 60x 90h**



22 kW  
18.920 kcal/h

**2.729,00**  
97 / 0,62

0,015 kW  
230V~  
50/60 Hz

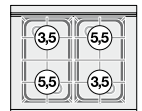

60



Le immagini presentate non sono vincolanti. La ditta si riserva di apportare modifiche senza preavviso. • The pictures are purely representative. The manufacturer reserves the right to modify the technical data and models without previous notice. • Les images

LO

présentées ne nous engagent pas. La Société se réserve le droit d'apporter tout modification sans préavis. • Die dargestellten Abbildungen sind nicht verbindlich. Technische Änderungen vorbehalten. • Las imágenes presentadas no son vinculantes. El Fabricante se reserva el derecho de modificar sus productos sin previo aviso.

01/20

25

MOD. \_\_\_\_\_  
COD. \_\_\_\_\_

DESCRIZIONE/DESCRIPTION/BEZEICHNUNG/DESCRIPTION/DESCRIPCIÓN  
DIMENSIONI/DIMENSIONS/ABMESSUNGEN/DIMENSIONS/DIMENSIONES

POTENZA/POWER/LEISTUNG/PUISSANCE/POTENCIA  
VOLTAGGIO/VOLTAGE/SPANNUNG/VOLTAGE/VOLTAJE

⚡ kW kcal/h ⚡ kW V~ Hz PREZZO/PRICE € KG / M<sup>3</sup>  
PREIS/PRIX/PRECIO

**CF6-610G**  
06681050

**CUCINA A GAS 6 FUOCHI FORNO A GAS STATICO CON GRILL CM. 64X39X35H, TEMP: 125÷275°C, CON 1 GRIGLIA CM.53X32,5 GN1/1 - PORTA VETRO**

**EN** Gas range - N. 6 burners - Gas static oven with grill cm. 64x39x35h, temp: 125÷275°C, with 1 grid cm.53x32,5 GN1/1 - glass door • **DE** Gasherd - N. 6 Kochstellen - Gas statischer Backofen mit grill cm. 64x39x35h, temp: 125÷275°C, mit 1 Rost cm.53x32,5 GN1/1 - Glastür • **FR** Cuisinière gaz - N. 6 feux vifs - Four gaz statique avec grill cm. 64x39x35h, temp: 125÷275°C, avec 1 grille cm.53x32,5 GN1/1 - Porte vitrée • **ES** Cocina gas - N. 6 quemadores - Horno gas estático con asador cm. 64x39x35h, temp: 125÷275°C, con 1 parilla cm.53x32,5 GN1/1 - Puerta vidrio  
**cm. 100x 60x 90h**



⚡ 31 kW 2.925,00  
26.660 kcal/h 106 / 0,77

⚡ 0,015 kW  
230V~  
50/60 Hz

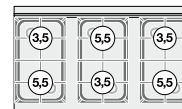

**CF6-610G**  
06681051

**CUCINA A GAS 6 FUOCHI FORNO A GAS STATICO CON GRILL CM. 64X39X35H, TEMP: 125÷275°C, CON 1 GRIGLIA CM.53X32,5 GN1/1 - PORTA CIECA INOX**

**EN** Gas range - N. 6 burners - Gas static oven with grill cm. 64x39x35h, temp: 125÷275°C, with 1 grid cm.53x32,5 GN1/1 - Stainless steel door • **DE** Gasherd - N. 6 Kochstellen - Gas statischer Backofen mit grill cm. 64x39x35h, temp: 125÷275°C, mit 1 Rost cm.53x32,5 GN1/1 - Edelstahltür/Porte acier inoxydable • **FR** Cuisinière gaz - N. 6 feux vifs - Four gaz statique avec grill cm. 64x39x35h, temp: 125÷275°C, avec 1 grille cm.53x32,5 GN1/1 - Porte acier inoxydable • **ES** Cocina gas - N. 6 quemadores - Horno gas estático con asador cm. 64x39x35h, temp: 125÷275°C, con 1 parilla cm.53x32,5 GN1/1 - Puerta ciega inox  
**cm. 100x 60x 90h**



⚡ 31 kW 2.925,00  
26.660 kcal/h 106 / 0,77

⚡ 0,015 kW  
230V~  
50/60 Hz

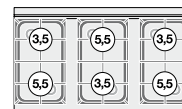

**CF4-68GEM**  
06690860

**CUCINA MISTA 4 FUOCHI CON FORNO ELETTRICO STATICO CON GRILL CM. 64X42X35H, TEMP: 50÷250°C, CON 1 GRIGLIA CM.53X32,5 GN1/1 - PORTA VETRO**

**EN** Combined range static oven - N. 4 burners Static oven with grill cm. 64x42x35h, temp: 50÷250°C, with 1 grid cm.53x32,5 GN1/1 - Glass door • **DE** Gemischtherd statischer Ofen - N. 4 Kochstellen Statischer Ofen mit Grill cm. 64x42x35h, temp: 50÷250°C, mit 1 Rost cm.53x32,5 GN1/1 - Glastür • **FR** Cuisinière mixte gaz four statique - N. 4 feux vifs Four statique avec grill cm. 64x42x35h, temp: 50÷250°C, avec 1 grille cm.53x32,5 GN1/1 - Porte vitrée • **ES** Cocina mixta horno estático - N. 4 quemadores Horno estático con asador cm. 64x42x35h, temp: 50÷250°C, con 1 parilla cm.53x32,5 GN1/1 - Puerta vidrio  
**cm. 80x 60x 90h**



⚡ 18 kW 2.395,00  
15.480 kcal/h 97 / 0,62

⚡ 2,62 kW  
230V~  
50/60 Hz

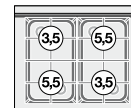

**CF4-68GEM**  
06690861

**CUCINA MISTA 4 FUOCHI CON FORNO ELETTRICO STATICO CON GRILL CM. 64X42X35H, TEMP: 50÷250°C, CON 1 GRIGLIA CM.53X32,5 GN1/1 - PORTA CIECA INOX**

**EN** Combined range static oven - N. 4 burners Static oven with grill cm. 64x42x35h, temp: 50÷250°C, with 1 grid cm.53x32,5 GN1/1 - Stainless steel door • **DE** Gemischtherd statischer Ofen - N. 4 Kochstellen Statischer Ofen mit Grill cm. 64x42x35h, temp: 50÷250°C, mit 1 Rost cm.53x32,5 GN1/1 - Edelstahltür • **FR** Cuisinière mixte gaz four estático - N. 4 feux vifs Four statique avec grill cm. 64x42x35h, temp: 50÷250°C, avec 1 grille cm.53x32,5 GN1/1 - Porte acier inoxydable • **ES** Cocina mixta horno estático - N. 4 quemadores Horno estático con asador cm. 64x42x35h, temp: 50÷250°C, con 1 parilla cm.53x32,5 GN1/1 - Puerta ciega inox  
**cm. 80x 60x 90h**



⚡ 18 kW 2.395,00  
15.480 kcal/h 97 / 0,62

⚡ 2,62 kW  
230V~  
50/60 Hz

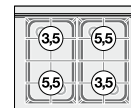



# CUCINE A GAS CON FORNO ELETTRICO

MOD. \_\_\_\_\_  
COD. \_\_\_\_\_

DESCRIZIONE/DESCRIPTION/BEZEICHNUNG/DESCRIPTION/DESCRIPCIÓN  
DIMENSIONI/DIMENSIONS/ABMESSUNGEN/DIMENSIONS/DIMENSIONES

POTENZA/POWER/LEISTUNG/PUISSANCE/POTENCIA  
VOLTAGGIO/VOLTAGE/SPANNUNG/VOLTAGE/VOLTAJE

⚡ kW \_\_\_\_\_  
kcal/h \_\_\_\_\_  
⚡ kw \_\_\_\_\_  
V~ \_\_\_\_\_  
Hz \_\_\_\_\_

PREZZO/PRICE € \_\_\_\_\_  
PREIS/PRIX/PRECIO € \_\_\_\_\_  
KG / M<sup>3</sup> \_\_\_\_\_

**CF6-610GEM CUCINA MISTA 6 FUOCHI CON FORNO ELETTRICO STATICO CON GRILL CM. 64X42X35H, TEMP: 50÷250°C, CON 1 GRIGLIA CM.53X32,5 GN1/1 - PORTA VETRO EN** Combined range static oven - N. 6 burners Static oven with grill cm. 64x42x35h, temp: 50÷250°C, with 1 grid cm.53x32,5 GN1/1 - Glass door • **DE** Gemischtherd statischer Ofen - N. 6 Kochstellen Statischer Ofen mit Grill cm. 64x42x35h, temp: 50÷250°C, mit 1 Rost cm.53x32,5 GN1/1 - Glastür • **FR** Cuisinière mixte gaz four statique - N. 6 feux vifs Four statique avec grill cm. 64x42x35h, temp: 50÷250°C, avec 1 grille cm.53x32,5 GN1/1 - Porte vitrée • **ES** Cocina mixta horno estático - N. 6 quemadores Horno estático con asador cm. 64x42x35h, temp: 50÷250°C, con 1 parilla cm.53x32,5 GN1/1 - Puerta vidrio  
**cm. 100x 60x 90h**



⚡ 27 kW \_\_\_\_\_ **2.814,00**  
23.193 kcal/h 106 / 0,77

⚡ 2,62 kW \_\_\_\_\_  
230V~ \_\_\_\_\_  
50/60 Hz \_\_\_\_\_

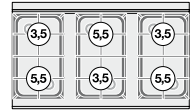

**CF6-610GEM CUCINA MISTA 6 FUOCHI CON FORNO ELETTRICO STATICO CON GRILL CM. 64X42X35H, TEMP: 50÷250°C, CON 1 GRIGLIA CM.53X32,5 GN1/1 - PORTA CIECA INOX EN** Combined range static oven - N. 6 burners Static oven with grill cm. 64x42x35h, temp: 50÷250°C, with 1 grid cm.53x32,5 GN1/1 - Stainless steel door • **DE** Gemischtherd statischer Ofen - N. 6 Kochstellen Statischer Ofen mit Grill cm. 64x42x35h, temp: 50÷250°C, mit 1 Rost cm.53x32,5 GN1/1 - Edelstahltür • **FR** Cuisinière mixte gaz four statique - N. 6 feux vifs Four statique avec grill cm. 64x42x35h, temp: 50÷250°C, avec 1 grille cm.53x32,5 GN1/1 - Porte acier inoxydable • **ES** Cocina mixta horno estático - N. 6 quemadores Horno estático con asador cm. 64x42x35h, temp: 50÷250°C, con 1 parilla cm.53x32,5 GN1/1 - Puerta ciega inox  
**cm. 100x 60x 90h**



⚡ 27 kW \_\_\_\_\_ **2.814,00**  
23.193 kcal/h 106 / 0,77

⚡ 2,62 kW \_\_\_\_\_  
230V~ \_\_\_\_\_  
50/60 Hz \_\_\_\_\_

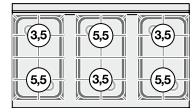

**CFM4-66ET CUCINA ELETTRICA TRIFASE CON 4 PIASTRE FORNO ELETTRICO MULTIFUNZIONE CAMERA CM. 46X37X35H, TEMP: 50÷250°C, CON 1 GRIGLIA CM.41X32,5 - PORTA VETRO EN** Range threephase - N. 4 plates Multifunction electric oven Chamber cm. 46x37x35h, temp: 50÷250°C, with 1 grid cm.41x32,5 - Glass door • **DE** Elektroherd dreiphasig - N. 4 Kochplatten Multifunktions-Elektroofen - cm. 46x37x35h, temp: 50÷250°C, mit 1 Rost cm.41x32,5 - Glastür • **FR** Cuisinière triphase - N. 4 plaques Four électrique à fonctions multiples - cm. 46x37x35h, temp: 50÷250°C, avec 1 grille cm.41x32,5 - Porte vitrée • **ES** Cocina trifásica - N. 4 planchas Horno eléctrico multifuncional - Cámara cm. 46x37x35h, temp: 50÷250°C, con 1 parilla cm.41x32,5 - Puerta vidrio  
**cm. 60x 60x 90h**



⚡ 9,05 kW \_\_\_\_\_ **2.466,00**  
400V~3N 70 / 0,47  
230V~3 \_\_\_\_\_  
230V~ \_\_\_\_\_  
50/60 Hz \_\_\_\_\_

**CFM4-66ET CUCINA ELETTRICA TRIFASE CON 4 PIASTRE FORNO ELETTRICO MULTIFUNZIONE CAMERA CM. 46X37X35H, TEMP: 50÷250°C, CON 1 GRIGLIA CM.41X32,5 - PORTA CIECA INOX EN** Range threephase - N. 4 plates Multifunction electric oven Chamber cm. 46x37x35h, temp: 50÷250°C, with 1 grid cm.41x32,5 - Stainless steel door • **DE** Elektroherd dreiphasig - N. 4 Kochplatten Multifunktions-Elektroofen - cm. 46x37x35h, temp: 50÷250°C, mit 1 Rost cm.41x32,5 - Edelstahltür • **FR** Cuisinière triphase - N. 4 plaques Four électrique à fonctions multiples - cm. 46x37x35h, temp: 50÷250°C, avec 1 grille cm.41x32,5 - Porte acier inoxydable • **ES** Cocina trifásica - N. 4 planchas Horno eléctrico multifuncional - Cámara cm. 46x37x35h, temp: 50÷250°C, con 1 parilla cm.41x32,5 - Puerta ciega inox  
**cm. 60x 60x 90h**



⚡ 9,05 kW \_\_\_\_\_ **2.466,00**  
400V~3N 70 / 0,47  
230V~3 \_\_\_\_\_  
230V~ \_\_\_\_\_  
50/60 Hz \_\_\_\_\_



Le immagini presentate non sono vincolanti. La ditta si riserva di apportare modifiche senza preavviso. • The pictures are purely representative. The manufacturer reserves the right to modify the technical data and models without previous notice. • Les images

LO

présentées ne nous engagent pas. La Société se réserve le droit d'apporter tout modification sans préavis. • Die dargestellten Abbildungen sind nicht verbindlich. Technische Änderungen vorbehalten. • Las imágenes presentadas no son vinculantes. El Fabricante se reserva el derecho de modificar sus productos sin previo aviso.

01/20

27

69



MOD. \_\_\_\_\_  
COD. \_\_\_\_\_

DESCRIZIONE/DESCRIPTION/BEZEICHNUNG/DESCRIPTION/DESCRIPCIÓN  
DIMENSIONI/DIMENSIONS/ABMESSUNGEN/DIMENSIONS/DIMENSIONES

POTENZA/POWER/LEISTUNG/PUISSANCE/POTENCIA  
VOLTAGGIO/VOLTAGE/SPANNUNG/VOLTAGE/VOLTAJE

⚡ kW kcal/h  
⚡ kW V~ Hz

PREZZO/PRICE €  
PREIS/PRIX/PRECIO €  
KG / M<sup>3</sup>

**CFM4-68ET**  
06660832

**CUCINA ELETTRICA TRIFASE CON 4 PIASTRE  
FORNO ELETTRICO MULTIFUNZIONE CAMERA  
CM. 64X37X35H, TEMP: 50÷250°C, CON 1  
GRIGLIA CM.53X32,5 GN1/1 - PORTA VETRO**  
EN Range threephase - N. 4 plates Multifunction electric oven Chamber cm. 64x37x35h, temp: 50÷250°C, with 1 grid cm.53x32,5 GN1/1 - Glass door • **DE** Elektroherd dreiphasig - N. 4 Kochplatten Multifunktions-Elektroofen cm. 64x37x35h, temp: 50÷250°C, mit 1 Rost cm.53x32,5 GN1/1 - Glastür • **FR** Cuisinière triphase - N. 4 plaques Four électrique à fonctions multiples cm. 64x37x35h, temp: 50÷250°C, avec 1 grille cm.53x32,5 GN1/1 - Porte vitrée • **ES** Cocina trifásica - N. 4 planchas Horno eléctrico multifuncional - Cámara cm. 64x37x35h, temp: 50÷250°C, con 1 parilla cm.53x32,5 GN1/1 - Puerta vidrio  
**cm. 80x 60x 90h**



⚡ 9,05 kW 3.026,00  
400V~3N 92 / 0,62  
230V~3  
230V~  
50/60 Hz

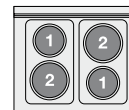

**CFM4-68ET**  
06660833

**CUCINA ELETTRICA TRIFASE CON 4 PIASTRE  
FORNO ELETTRICO MULTIFUNZIONE CAMERA  
CM. 64X37X35H, TEMP: 50÷250°C, CON 1  
GRIGLIA CM.53X32,5 GN1/1 - PORTA CIECA  
INOX**  
EN Range threephase - N. 4 plates Multifunction electric oven Chamber cm. 64x37x35h, temp: 50÷250°C, with 1 grid cm.53x32,5 GN1/1 - Stainless steel door • **DE** Elektroherd dreiphasig - N. 4 Kochplatten Multifunktions-Elektroofen cm. 64x37x35h, temp: 50÷250°C, mit 1 Rost cm.53x32,5 GN1/1 - Edelstahltür • **FR** Cuisinière triphase - N. 4 plaques Four électrique à fonctions multiples cm. 64x37x35h, temp: 50÷250°C, avec 1 grille cm.53x32,5 GN1/1 - Porte acier inoxydable • **ES** Cocina trifásica - N. 4 planchas Horno eléctrico multifuncional - Cámara cm. 64x37x35h, temp: 50÷250°C, con 1 parilla cm.53x32,5 GN1/1 - Puerta ciega inox  
**cm. 80x 60x 90h**



⚡ 9,05 kW 3.026,00  
400V~3N 92 / 0,62  
230V~3  
230V~  
50/60 Hz



**CFM6-610ET**  
06661032

**CUCINA ELETTRICA TRIFASE CON 6 PIASTRE  
FORNO ELETTRICO MULTIFUNZIONE CAMERA  
CM. 64X37X35H, TEMP: 50÷250°C, CON 1  
GRIGLIA CM.53X32,5 GN1/1 - PORTA VETRO**  
EN Range threephase - N. 6 plates Multifunction electric oven Chamber cm. 64x37x35h, temp: 50÷250°C, with 1 grid cm.53x32,5 GN1/1 - Glass door • **DE** Elektroherd dreiphasig - N. 6 Kochplatten Multifunktions-Elektroofen cm. 64x37x35h, temp: 50÷250°C, mit 1 Rost cm.53x32,5 GN1/1 - Glastür • **FR** Cuisinière triphase - N. 6 plaques Four électrique à fonctions multiples cm. 64x37x35h, temp: 50÷250°C, avec 1 grille cm.53x32,5 GN1/1 - Porte vitrée • **ES** Cocina trifásica - N. 6 planchas Horno eléctrico multifuncional - Cámara cm. 64x37x35h, temp: 50÷250°C, con 1 parilla cm.53x32,5 GN1/1 - Puerta vidrio  
**cm. 100x 60x 90h**



⚡ 12,05 kW 3.522,00  
400V~3N 96 / 0,77  
230V~3  
50/60 Hz

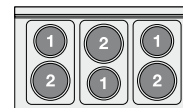

**CFM6-610ET**  
06661033

**CUCINA ELETTRICA TRIFASE CON 6 PIASTRE  
FORNO ELETTRICO MULTIFUNZIONE CAMERA  
CM. 64X37X35H, TEMP: 50÷250°C, CON 1  
GRIGLIA CM.53X32,5 GN1/1 - PORTA CIECA  
INOX**  
EN Range threephase - N. 6 plates Multifunction electric oven Chamber cm. 64x37x35h, temp: 50÷250°C, with 1 grid cm.53x32,5 GN1/1 - Stainless steel door • **DE** Elektroherd dreiphasig - N. 6 Kochplatten Multifunktions-Elektroofen cm. 64x37x35h, temp: 50÷250°C, mit 1 Rost cm.53x32,5 GN1/1 - Edelstahltür • **FR** Cuisinière triphase - N. 6 plaques Four électrique à fonctions multiples cm. 64x37x35h, temp: 50÷250°C, avec 1 grille cm.53x32,5 GN1/1 - Porte acier inoxydable • **ES** Cocina trifásica - N. 6 planchas Horno eléctrico multifuncional - Cámara cm. 64x37x35h, temp: 50÷250°C, con 1 parilla cm.53x32,5 GN1/1 - Puerta ciega inox  
**cm. 100x 60x 90h**

⚡ 12,05 kW 3.522,00  
400V~3N 96 / 0,77  
230V~3  
50/60 Hz

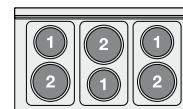

MOD. \_\_\_\_\_  
COD. \_\_\_\_\_

DESCRIZIONE/DESCRIPTION/BEZEICHNUNG/DESCRIPTION/DESCRIPCIÓN  
DIMENSIONI/DIMENSIONS/ABMESSUNGEN/DIMENSIONS/DIMENSIONES

POTENZA/POWER/LEISTUNG/PUISSANCE/POTENCIA  
VOLTAGGIO/VOLTAGE/SPANNUNG/VOLTAGE/VOLTAJE

⚡ kW kcal/h  
V~ Hz

PREZZO/PRICE €  
PREIS/PRIX/PRECIO €  
KG / M<sup>3</sup>

**CF4-68ET**  
06660830

**CUCINA ELETTRICA TRIFASE CON N. 4 PIASTRE - FORNO ELETTRICO STATICO CON GRILL**  
**CM. 64X42X35H, TEMP: 50÷250°C, CON 1 GRIGLIA CM.53X32,5 GN1/1 - PORTA VETRO**  
EN Range threephase - N. 4 plates - Static oven with grill cm. 64x42x35h, temp: 50÷250°C, with 1 grid cm.53x32,5 GN1/1 - Glass door • **DE** Elektroherd dreiphasig - N. 4 Kochplatten Statischer Ofen mit Grill cm. 64x42x35h, temp: 50÷250°C, mit 1 Rost cm.53x32,5 GN1/1 - Glastür • **FR** Cuisinière triphase - N. 4 plaques - Four statique avec grill cm. 64x42x35h, temp: 50÷250°C, avec 1 grille cm.53x32,5 GN1/1 - Porte vitrée • **ES** Cocina trifásica - N. 4 planchas - Horno estático con asador cm. 64x42x35h, temp: 50÷250°C, con 1 parilla cm.53x32,5 GN1/1 - Puerta vidrio  
**cm. 80x 60x 90h**



⚡ 8,62 kW 2.245,00  
400V~3N 91 / 0,62  
230V~3  
230V~  
50/60 Hz

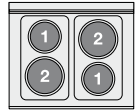

**CF4-68ET**  
06660831

**CUCINA ELETTRICA TRIFASE CON N. 4 PIASTRE - FORNO ELETTRICO STATICO CON GRILL**  
**CM. 64X42X35H, TEMP: 50÷250°C, CON 1 GRIGLIA CM.53X32,5 GN1/1 - PORTA CIECA INOX**  
EN Range threephase - N. 4 plates - Static oven with grill cm. 64x42x35h, temp: 50÷250°C, with 1 grid cm.53x32,5 GN1/1 - Stainless steel door • **DE** Elektroherd dreiphasig - N. 4 Kochplatten Statischer Ofen mit Grill cm. 64x42x35h, temp: 50÷250°C, mit 1 Rost cm.53x32,5 GN1/1 - Edelstahltür • **FR** Cuisinière triphase - N. 4 plaques - Four statique avec grill cm. 64x42x35h, temp: 50÷250°C, avec 1 grille cm.53x32,5 GN1/1 - Porte acier inoxydable • **ES** Cocina trifásica - N. 4 planchas - Horno estático con asador cm. 64x42x35h, temp: 50÷250°C, con 1 parilla cm.53x32,5 GN1/1 - Puerta ciega inox  
**cm. 80x 60x 90h**



⚡ 8,62 kW 2.245,00  
400V~3N 91 / 0,62  
230V~3  
230V~  
50/60 Hz

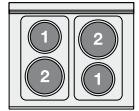

**CF6-610ET**  
06661030

**CUCINA ELETTRICA TRIFASE CON N. 6 PIASTRE - FORNO ELETTRICO STATICO CON GRILL**  
**CM. 64X42X35H, TEMP: 50÷250°C, CON 1 GRIGLIA CM.53X32,5 GN1/1 - PORTA VETRO**  
EN Range threephase - N. 6 plates - Static oven with grill cm. 64x42x35h, temp: 50÷250°C, with 1 grid cm.53x32,5 GN1/1 - Glass door • **DE** Elektroherd dreiphasig - N. 6 Kochplatten Statischer Ofen mit Grill cm. 64x42x35h, temp: 50÷250°C, mit 1 Rost cm.53x32,5 GN1/1 - Glastür • **FR** Cuisinière triphase - N. 6 plaques - Four statique avec grill cm. 64x42x35h, temp: 50÷250°C, avec 1 grille cm.53x32,5 GN1/1 - Porte vitrée • **ES** Cocina trifásica - N. 6 planchas - Horno estático con asador cm. 64x42x35h, temp: 50÷250°C, con 1 parilla cm.53x32,5 GN1/1 - Puerta vidrio  
**cm. 100x 60x 90h**



⚡ 11,62 kW 2.596,00  
400V~3N 95 / 0,77  
230V~3  
50/60 Hz



**CF6-610ET**  
06661031

**CUCINA ELETTRICA TRIFASE CON N. 6 PIASTRE - FORNO ELETTRICO STATICO CON GRILL**  
**CM. 64X42X35H, TEMP: 50÷250°C, CON 1 GRIGLIA CM.53X32,5 GN1/1 - PORTA CIECA INOX**  
EN Range threephase - N. 6 plates - Static oven with grill cm. 64x42x35h, temp: 50÷250°C, with 1 grid cm.53x32,5 GN1/1 - Stainless steel door • **DE** Elektroherd dreiphasig - N. 6 Kochplatten Statischer Ofen mit Grill cm. 64x42x35h, temp: 50÷250°C, mit 1 Rost cm.53x32,5 GN1/1 - Edelstahltür • **FR** Cuisinière triphase - N. 6 plaques - Four statique avec grill cm. 64x42x35h, temp: 50÷250°C, avec 1 grille cm.53x32,5 GN1/1 - Porte acier inoxydable • **ES** Cocina trifásica - N. 6 planchas - Horno estático con asador cm. 64x42x35h, temp: 50÷250°C, con 1 parilla cm.53x32,5 GN1/1 - Puerta ciega inox  
**cm. 100x 60x 90h**

⚡ 11,62 kW 2.596,00  
400V~3N 95 / 0,77  
230V~3  
50/60 Hz



# CUCINE A GAS CON FORNO ELETTRICO

MOD. \_\_\_\_\_  
COD. \_\_\_\_\_

DESCRIZIONE/DESCRIPTION/BEZEICHNUNG/DESCRIPTION/DESCRIPCIÓN  
DIMENSIONI/DIMENSIONS/ABMESSUNGEN/DIMENSIONS/DIMENSIONES

POTENZA/POWER/LEISTUNG/PUISSANCE/POTENCIA  
VOLTAGGIO/VOLTAGE/SPANNUNG/VOLTAGE/VOLTAJE

⚡ 18 kW  
15.480 kcal/h

PREZZO/PRICE €  
PREIS/PRIX/PRECIO €  
KG / M<sup>3</sup>

**CFM4-66GEM CUCINA MISTA 4 FUOCHI CON FORNO ELETTRICO MULTIFUNZIONE - CAMERA CM. 46X37X35H, TEMP: 50÷250°C, CON 1 GRIGLIA CM.41X32,5 - PORTA VETRO**

06690662

**EN** Combined range - N. 4 burners Multifunction oven - Chamber cm. 46x37x35h, temp: 50÷250°C, with 1 grid cm.41x32,5 - Glass door • **DE** Gemischtherd - N. 4 Kochstellen Multifunktions-Ofen - cm. 46x37x35h, temp: 50÷250°C, mit 1 Rost cm.41x32,5 - Glastür • **FR** Cuisinière mixte - N. 4 feux vifs Four à fonctions multiples - cm. 46x37x35h, temp: 50÷250°C, avec 1 grille cm.41x32,5 - Porte vitrée • **ES** Cocina mixta - N. 4 quemadores Horno multifuncional - Cámara cm. 46x37x35h, temp: 50÷250°C, con 1 parilla cm.41x32,5 - Puerta vidrio  
**cm. 60x 60x 90h**



⚡ 18 kW  
15.480 kcal/h

**2.697,00**  
70 / 0,47

⚡ 3,05 kW  
230V~  
50/60 Hz

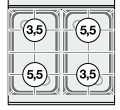

**CFM4-66GEM CUCINA MISTA 4 FUOCHI CON FORNO ELETTRICO MULTIFUNZIONE - CAMERA CM. 46X37X35H, TEMP: 50÷250°C, CON 1 GRIGLIA CM.41X32,5 - PORTA CIECA INOX**

06690663

**EN** Combined range - N. 4 burners Multifunction oven - Chamber cm. 46x37x35h, temp: 50÷250°C, with 1 grid cm.41x32,5 - Stainless steel door • **DE** Gemischtherd - N. 4 Kochstellen Multifunktions-Ofen - cm. 46x37x35h, temp: 50÷250°C, mit 1 Rost cm.41x32,5 - Edelstahltür • **FR** Cuisinière mixte - N. 4 feux vifs Four à fonctions multiples - cm. 46x37x35h, temp: 50÷250°C, avec 1 grille cm.41x32,5 - Porte acier inoxydatable • **ES** Cocina mixta - N. 4 quemadores Horno multifuncional - Cámara cm. 46x37x35h, temp: 50÷250°C, con 1 parilla cm.41x32,5 - Puerta ciega inox  
**cm. 60x 60x 90h**



⚡ 18 kW  
15.480 kcal/h

**2.697,00**  
70 / 0,47

⚡ 3,05 kW  
230V~  
50/60 Hz

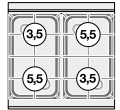

**CFM4-68GEM CUCINA MISTA 4 FUOCHI CON FORNO ELETTRICO MULTIFUNZIONE - CAMERA CM. 64X37X35H, TEMP: 50÷250°C, CON 1 GRIGLIA CM.53X32,5 GN1/1 - PORTA VETRO**

06690862

**EN** Combined range - N. 4 burners Multifunction oven - Chamber cm. 64x37x35h, temp: 50÷250°C, with 1 grid cm.53x32,5 GN1/1 - Glass door • **DE** Gemischtherd - N. 4 Kochstellen Multifunktions-Ofen cm. 64x37x35h, temp: 50÷250°C, with 1 grid cm.53x32,5 GN1/1 - Glastür • **FR** Cuisinière mixte - N. 4 feux vifs Four à fonctions multiples cm. 64x37x35h, temp: 50÷250°C, avec 1 grille cm.53x32,5 GN1/1 - Porte vitrée • **ES** Cocina mixta - N. 4 quemadores Horno multifuncional - Cámara cm. 64x37x35h, temp: 50÷250°C, con 1 parilla cm.53x32,5 GN1/1 - Puerta vidrio  
**cm. 80x 60x 90h**



⚡ 18 kW  
15.480 kcal/h

**3.497,00**  
98 / 0,62

⚡ 3,05 kW  
230V~  
50/60 Hz

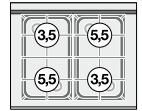

**CFM4-68GEM CUCINA MISTA 4 FUOCHI CON FORNO ELETTRICO MULTIFUNZIONE - CAMERA CM. 64X37X35H, TEMP: 50÷250°C, CON 1 GRIGLIA CM.53X32,5 GN1/1 - PORTA CIECA INOX**

06690863

**EN** Combined range - N. 4 burners Multifunction oven - Chamber cm. 64x37x35h, temp: 50÷250°C, with 1 grid cm.53x32,5 GN1/1 - Stainless steel door • **DE** Gemischtherd - N. 4 Kochstellen Multifunktions-Ofen cm. 64x37x35h, temp: 50÷250°C, with 1 grid cm.53x32,5 GN1/1 - Edelstahltür • **FR** Cuisinière mixte - N. 4 feux vifs Four à fonctions multiples cm. 64x37x35h, temp: 50÷250°C, avec 1 grille cm.53x32,5 GN1/1 - Porte acier inoxydatable • **ES** Cocina mixta - N. 4 quemadores Horno multifuncional - Cámara cm. 64x37x35h, temp: 50÷250°C, con 1 parilla cm.53x32,5 GN1/1 - Puerta ciega inox  
**cm. 80x 60x 90h**



⚡ 18 kW  
15.480 kcal/h

**3.497,00**  
98 / 0,62

⚡ 3,05 kW  
230V~  
50/60 Hz

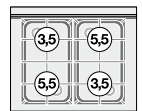



# CUCINE A GAS CON FORNO ELETTRICO

MOD. \_\_\_\_\_  
COD. \_\_\_\_\_

DESCRIZIONE/DESCRIPTION/BEZEICHNUNG/DESCRIPTION/DESCRIPCIÓN  
DIMENSIONI/DIMENSIONS/ABMESSUNGEN/DIMENSIONS/DIMENSIONES

POTENZA/POWER/LEISTUNG/PUISSANCE/POTENCIA  
VOLTAGGIO/VOLTAGE/SPANNUNG/VOLTAGE/VOLTAJE

⚡ kW  
kcal/h

PREZZO/PRICE €  
PREIS/PRIX/PRECIO €  
KG / M<sup>3</sup>

**CFM6-610GEM CUCINA MISTA 6 FUOCHI CON FORNO ELETTRICO MULTIFUNZIONE - CAMERA CM. 64X37X35H, TEMP: 50÷250°C, CON 1 GRIGLIA CM.53X32,5 GN1/1 - PORTA VETRO EN** Combined range - N. 6 burners Multifunction oven - Chamber cm. 64x37x35h, temp: 50÷250°C, with 1 grid cm.53x32,5 GN1/1 - Glass door • **DE** Gemischtherd - N. 6 Kochstellen Multifunktions-Ofen cm. 64x37x35h, temp: 50÷250°C, mit 1 Rost cm.53x32,5 GN1/1 - Glastür • **FR** Cuisinière mixte - N. 6 feux vifs Four à fonctions multiples cm. 64x37x35h, temp: 50÷250°C, avec 1 grille cm.53x32,5 GN1/1 - Porte vitrée • **ES** Cocina mixta - N. 6 quemadores Horno multifuncional - Cámara cm. 64x37x35h, temp: 50÷250°C, con 1 parilla cm.53x32,5 GN1/1 - Puerta vidrio  
**cm. 100x 60x 90h**



⚡ 27 kW  
23.193 kcal/h

**3.912,00**  
107 / 0,77

⚡ 3,05 kW  
230V~  
50/60 Hz

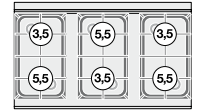

**CFM6-610GEM CUCINA MISTA 6 FUOCHI CON FORNO ELETTRICO MULTIFUNZIONE - CAMERA CM. 64X37X35H, TEMP: 50÷250°C, CON 1 GRIGLIA CM.53X32,5 GN1/1 - PORTA CIECA INOX EN** Combined range - N. 6 burners Multifunction oven - Chamber cm. 64x37x35h, temp: 50÷250°C, with 1 grid cm.53x32,5 GN1/1 - Stainless steel door • **DE** Gemischtherd - N. 6 Kochstellen Multifunktions-Ofen cm. 64x37x35h, temp: 50÷250°C, mit 1 Rost cm.53x32,5 GN1/1 - Edelstahltür • **FR** Cuisinière mixte - N. 6 feux vifs Four à fonctions multiples cm. 64x37x35h, temp: 50÷250°C, avec 1 grille cm.53x32,5 GN1/1 - Porte acier inoxydable • **ES** Cocina mixta - N. 6 quemadores Horno multifuncional - Cámara cm. 64x37x35h, temp: 50÷250°C, con 1 parilla cm.53x32,5 GN1/1 - Puerta ciega inox  
**cm. 100x 60x 90h**



⚡ 27 kW  
23.193 kcal/h

**3.912,00**  
107 / 0,77

⚡ 3,05 kW  
230V~  
50/60 Hz

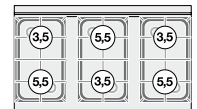

**TPF4-610G TUTTA PIASTRA + 4 FUOCHI FORNO A GAS STATICO CON GRILL CM. 64X39X35H, TEMP: 125÷275°C, CON 1 GRIGLIA CM.53X32,5 GN1/1 - PIASTRA CM. 37X50 - PORTA VETRO EN** Solid top + 4 burners on Gas static oven with grill cm. 64x39x35h, temp: 125÷275°C, with 1 grid cm.53x32,5 GN1/1, Plate cm. 37x50 - Glass door • **DE** Kochplatte + 4 Gaskochstellen auf Gas statischer Backofen mit grill cm. 64x39x35h, temp: 125÷275°C, mit 1 Rost cm.53x32,5 GN1/1 Platte cm. 37x50 - Glastür • **FR** Toute plaque + 4 brûleurs sur Four gaz statique avec grill cm. 64x39x35h, temp: 125÷275°C, avec 1 grille cm.53x32,5 GN1/1 Plaque cm. 37x50 - Porte vitrée • **ES** Placa de cocción + 4 fuegos con Horno gas estático con asador cm. 64x39x35h, temp: 125÷275°C, con 1 parilla cm.53x32,5 GN1/1, Placa cm. 37x50 - Puerta vidrio  
**cm. 100x 60x 90h**



⚡ 27,5 kW  
23.650 kcal/h

**4.023,00**  
165 / 0,77

⚡ 0,015 kW  
230V~  
50/60 Hz

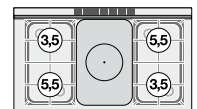

**TPF4-610G TUTTA PIASTRA + 4 FUOCHI FORNO A GAS STATICO CON GRILL CM. 64X39X35H, TEMP: 125÷275°C, CON 1 GRIGLIA CM.53X32,5 GN1/1 - PIASTRA CM. 37X50 - PORTA CIECA INOX EN** Solid top + 4 burners on Gas static oven with grill cm. 64x39x35h, temp: 125÷275°C, with 1 grid cm.53x32,5 GN1/1, Plate cm. 37x50 - Stainless steel door • **DE** Kochplatte + 4 Gaskochstellen auf Gas statischer Backofen mit grill cm. 64x39x35h, temp: 125÷275°C, mit 1 Rost cm.53x32,5 GN1/1 Platte cm. 37x50 - Edelstahltür • **FR** Toute plaque + 4 brûleurs sur Four gaz statique avec grill cm. 64x39x35h, temp: 125÷275°C, avec 1 grille cm.53x32,5 GN1/1 Plaque cm. 37x50 - Porte acier inoxydable • **ES** Placa de cocción + 4 fuegos con Horno gas estático con asador cm. 64x39x35h, temp: 125÷275°C, con 1 parilla cm.53x32,5 GN1/1, Placa cm. 37x50 - Puerta ciega inox  
**cm. 100x 60x 90h**



⚡ 27,5 kW  
23.650 kcal/h

**4.023,00**  
165 / 0,77

⚡ 0,015 kW  
230V~  
50/60 Hz

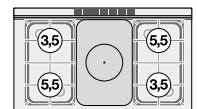

Le immagini presentate non sono vincolanti. La ditta si riserva di apportare modifiche senza preavviso. • The pictures are purely representative. The manufacturer reserves the right to modify the technical data and models without previous notice. • Les images

LO

présentées ne nous engagent pas. La Société se réserve le droit d'apporter tout modification sans préavis. • Die dargestellten Abbildungen sind nicht verbindlich. Technische Änderungen vorbehalten. • Las imágenes presentadas no son vinculantes. El Fabricante se reserva el derecho de modificar sus productos sin previo aviso.

01/20

31

69

# TUTTAPIASTRA A GAS CON FORNO ELETTRICO

MOD. \_\_\_\_\_  
COD. \_\_\_\_\_

DESCRIZIONE/DESCRIPTION/BEZEICHNUNG/DESCRIPTION/DESCRIPCIÓN  
DIMENSIONI/DIMENSIONS/ABMESSUNGEN/DIMENSIONS/DIMENSIONES

POTENZA/POWER/LEISTUNG/PUISSANCE/POTENCIA  
VOLTAGGIO/VOLTAGE/SPANNUNG/VOLTAGE/VOLTAJE

⚡ kW kcal/h  
⚡ kW V~ Hz

PREZZO/PRICE €  
PREIS/PRIX/PRECIO €  
KG / M<sup>3</sup>

## TPF4-610GEM TUTTA PIASTRA + 4 FUOCHI CON FORNO 06731060 ELETTRICO STATICO - CAMERA CM.

**64X42X35H, TEMP: 50÷250°C, CON 1  
GRIGLIA CM.53X32,5 GN1/1 - PIASTRA CM.  
37X50 - PORTA VETRO**

**EN** Solid top + 4 burners Traditional electric oven - chamber cm 64x42x35h, temp: 50÷250°C, with 1 grid cm.53x32,5 GN1/1, Plate cm. 37x50 - Glass door  
• **DE** Kochplatte + 4 Gaskochstellen Statischer elektro-backofen cm. 64x42x35h, temp: 50÷250°C, mit 1 Rost cm.53x32,5 GN1/1 Platte cm. 37x50 - Glastür  
• **FR** Toute plaque + 4 brûleurs vifs Four électrique statique chambre cm.64x42x35h, temp: 50÷250°C, avec 1 grille cm.53x32,5 GN1/1 Plaque cm. 37x50 - Porte vitrée  
• **ES** Placa de cocción + 4 fuegos Horno eléctrico estático cámara cm. 64x42x35h, temp: 50÷250°C, con 1 parilla cm.53x32,5 GN1/1, Placa cm. 37x50 - Puerta vidrio

**cm. 100x 60x 90h**



⚡ 23,5 kW 3.910,00  
20.210 kcal/h 165 / 0,77

⚡ 2,62 kW  
230V~  
50/60 Hz

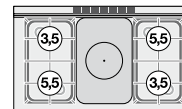

## TPF4-610GEM TUTTA PIASTRA + 4 FUOCHI CON FORNO 06731061 ELETTRICO STATICO - CAMERA CM.

**64X42X35H, TEMP: 50÷250°C, CON 1  
GRIGLIA CM.53X32,5 GN1/1 - PIASTRA CM.  
37X50 - PORTA CIECA INOX**

**EN** Solid top + 4 burners Traditional electric oven - chamber cm 64x42x35h, temp: 50÷250°C, with 1 grid cm.53x32,5 GN1/1, Plate cm. 37x50 - Stainless steel door  
• **DE** Kochplatte + 4 Gaskochstellen Statischer elektro-backofen cm. 64x42x35h, temp: 50÷250°C, mit 1 Rost cm.53x32,5 GN1/1 Platte cm. 37x50 - Edelstahltür  
• **FR** Toute plaque + 4 brûleurs vifs Four électrique statique chambre cm.64x42x35h, temp: 50÷250°C, avec 1 grille cm.53x32,5 GN1/1 Plaque cm. 37x50 - Porte acier inoxydable  
• **ES** Placa de cocción + 4 fuegos Horno eléctrico estático cámara cm. 64x42x35h, temp: 50÷250°C, con 1 parilla cm.53x32,5 GN1/1, Placa cm. 37x50 - Puerta ciega inox

**cm. 100x 60x 90h**



⚡ 23,5 kW 3.910,00  
20.210 kcal/h 165 / 0,77

⚡ 2,62 kW  
230V~  
50/60 Hz

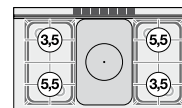

## TPFM4-610GEM TUTTA PIASTRA + 4 FUOCHI CON FORNO 06731062 ELETTRICO MULTIFUNZIONE CM. 64X37X35H,

**TEMP: 50÷250°C, CON 1 GRIGLIA  
CM.53X32,5 GN1/1 - PIASTRA CM. 37X50 -  
PORTA VETRO**

**EN** Solid top + 4 burners Multifunction electric oven cm. 64x37x35h, temp: 50÷250°C, with 1 grid cm.53x32,5 GN1/1, Plate cm. 37x50 - Glass door  
• **DE** Kochplatte + 4 Gaskochstellen Multifunktions-Elektroofen cm. 64x37x35h, temp: 50÷250°C, mit 1 Rost cm.53x32,5 GN1/1 Platte cm. 37x50 - Glastür  
• **FR** Toute plaque + 4 brûleurs vifs Four électrique à fonctions multiples cm. 64x37x35h, temp: 50÷250°C, avec 1 grille cm.53x32,5 GN1/1 Plaque cm. 37x50 - Porte vitrée  
• **ES** Placa de cocción + 4 fuegos Horno eléctrico multifuncional cm. 64x37x35h, temp: 50÷250°C, con 1 parilla cm.53x32,5 GN1/1, Placa cm. 37x50 - Puerta vidrio

**cm. 100x 60x 90h**



⚡ 23,5 kW 5.043,00  
20.210 kcal/h 166 / 0,77

⚡ 3,05 kW  
230V~  
50/60 Hz

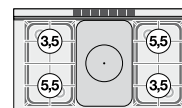

# TUTTAPIASTRA A GAS CON FORNO ELETTRICO

MOD. \_\_\_\_\_  
COD. \_\_\_\_\_

DESCRIZIONE/DESCRIPTION/BEZEICHNUNG/DESCRIPTION/DESCRIPCIÓN  
DIMENSIONI/DIMENSIONS/ABMESSUNGEN/DIMENSIONS/DIMENSIONES

POTENZA/POWER/LEISTUNG/PUISSANCE/POTENCIA  
VOLTAGGIO/VOLTAGE/SPANNUNG/VOLTAGE/VOLTAJE

⚡ kW kcal/h  
⚡ kw V~ Hz

PREZZO/PRICE €  
PREIS/PRIX/PRECIO €  
KG / M<sup>3</sup>

**TPFM4-610GEM TUTTA PIASTRA + 4 FUOCHI CON FORNO ELETTRICO MULTIFUNZIONE CM. 64X37X35H, TEMP: 50÷250°C, CON 1 GRIGLIA CM.53X32,5 GN1/1 - PIASTRA CM. 37X50 - PORTA CIECA INOX**

**EN** Solid top + 4 burners Multifunction electric oven cm. 64x37x35h, temp: 50÷250°C, with 1 grid cm.53x32,5 GN1/1, Plate cm. 37x50 - Stainless steel door  
• **DE** Kochplatte + 4 Gaskochstellen Multifunktions-Elektroofen cm. 64x37x35h, temp: 50÷250°C, mit 1 Rost cm.53x32,5 GN1/1 Platte cm. 37x50 - Edelstahltür  
• **FR** Toute plaque + 4 brûleurs vifs Four électrique à fonctions multiples cm. 64x37x35h, temp: 50÷250°C, avec 1 grille cm.53x32,5 GN1/1 Plaque cm. 37x50 - Porte acier inoxydable • **ES** Placa de cocción + 4 fuegos Horno eléctrico multifuncional cm. 64x37x35h, temp: 50÷250°C, con 1 parilla cm.53x32,5 GN1/1, Placa cm. 37x50 - Puerta ciega inox  
**cm. 100x 60x 90h**



⚡ 23,5 kW 5.043,00  
20.210 kcal/h 166 / 0,77

⚡ 3,05 kW  
230V~  
50/60 Hz

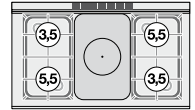

**CFMC4-66ET CUCINA CON PIANO IN VETRO CERAMICA VETRO CM. 58X44 FORNO MULTIFUNZIONE - CAMERA CM. 46X37X35H, TEMP: 50÷250°C, CON 1 GRIGLIA CM.41X32,5 - PORTA VETRO**

**EN** Range threephase - Ceramic, Glass: cm. 58x44 Multifunction oven - Chamber cm. 46x37x35h, temp: 50÷250°C, with 1 grid cm.41x32,5 - Glass door  
• **DE** Elektroherd dreiphasing - Ceran-Kochfläche cm. 58x44 Multifunktions-Ofen - cm. 46x37x35h, temp: 50÷250°C, mit 1 Rost cm.41x32,5 - Glastür • **FR** Cuisinière triphase - Vitrocéramique Plaque cm. 58x44 Four à fonctions multiples - cm. 46x37x35h, temp: 50÷250°C, avec 1 grille cm.41x32,5 - Porte vitrée • **ES** Cocina trifasica - Placa vitrocerámica, cristal cm. 58x44 Horno multifuncional - Cámara cm. 46x37x35h, temp: 50÷250°C, con 1 parilla cm.41x32,5 - Puerta vidrio  
**cm. 60x 60x 90h**



⚡ 9,05 kW 3.799,00  
400V~3N 70 / 0,47  
230V~3  
230V~

50/60 Hz

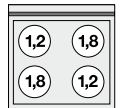

**CFMC4-66ET CUCINA CON PIANO IN VETRO CERAMICA VETRO CM. 58X44 FORNO MULTIFUNZIONE - CAMERA CM. 46X37X35H, TEMP: 50÷250°C, CON 1 GRIGLIA CM.41X32,5 - PORTA CIECA INOX**

**EN** Range threephase - Ceramic, Glass: cm. 58x44 Multifunction oven - Chamber cm. 46x37x35h, temp: 50÷250°C, with 1 grid cm.41x32,5 - Stainless steel door  
• **DE** Elektroherd dreiphasing - Ceran-Kochfläche cm. 58x44 Multifunktions-Ofen - cm. 46x37x35h, temp: 50÷250°C, mit 1 Rost cm.41x32,5 - Edelstahltür  
• **FR** Cuisinière triphase - Vitrocéramique Plaque cm. 58x44 Four à fonctions multiples - cm. 46x37x35h, temp: 50÷250°C, avec 1 grille cm.41x32,5 - Porte acier inoxydable • **ES** Cocina trifasica - Placa vitrocerámica, cristal cm. 58x44 Horno multifuncional - Cámara cm. 46x37x35h, temp: 50÷250°C, con 1 parilla cm.41x32,5 - Puerta ciega inox  
**cm. 60x 60x 90h**



⚡ 9,05 kW 3.799,00  
400V~3N 70 / 0,47  
230V~3  
230V~

50/60 Hz

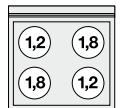

**PT2/3-CFM66 PORTATEGLIE GN 2/3. PER CFM-66**  
06460023 **EN** Frame for oven plates GN 2/3, for CFM-66 • **DE** Auflangeschienen für Backbleche GN 2/3 für CFM-66  
• **FR** Kit porte-plaques GN 2/3 pour CFM-66 • **ES** Portacazuelas GN2/3 para CFM-66

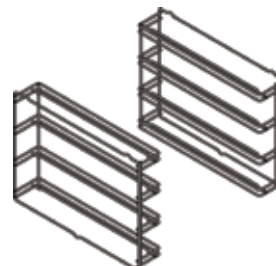

72,00  
5 / 0,02



Le immagini presentate non sono vincolanti. La ditta si riserva di apportare modifiche senza preavviso. • The pictures are purely representative. The manufacturer reserves the right to modify the technical data and models without previous notice. • Les images

LO

présentées ne nous engagent pas. La Société se réserve le droit d'apporter tout modification sans préavis. • Die dargestellten Abbildungen sind nicht verbindlich. Technische Änderungen vorbehalten. • Las imágenes presentadas no son vinculantes. El Fabricante se reserva el derecho de modificar sus productos sin previo aviso.

01/20

33

60



MOD. \_\_\_\_\_  
COD. \_\_\_\_\_

DESCRIZIONE/DESCRIPTION/BEZEICHNUNG/DESCRIPTION/DESCRIPCIÓN  
DIMENSIONI/DIMENSIONS/ABMESSUNGEN/DIMENSIONS/DIMENSIONES

POTENZA/POWER/LEISTUNG/PUISSANCE/POTENCIA  
VOLTAGGIO/VOLTAGE/SPANNUNG/VOLTAGE/VOLTAJE

⚡ 21 kW  
18.060 kcal/h

PREZZO/PRICE €  
PREIS/PRIX/PRECIO €  
KG / M<sup>3</sup>

**CF2-68G**  
06780851

**CUCINA A GAS 2 FUOCHI FORNO A GAS STATICO CON GRILL CM. 67X38X34H, TEMP: 125÷275°C, CON 1 GRIGLIA CM.65X36**

**EN** Gas range - N. 2 burners - Gas static oven with grill cm. 67x38x34h, temp: 125÷275°C, with 1 grid cm.65x36 • **DE** Gasherd - N. 2 Kochstellen - Gas statischer Backofen mit Grill cm. 67x38x34h, temp: 125÷275°C, mit 1 Rost cm.65x36 • **FR** Forneau gaz - N. 2 feux vifs - Four a gaz statique avec grill cm. 67x38x34h, temp: 125÷275°C, avec 1 grille cm.65x36 • **ES** Cocina gas - N. 2 quemadores Horno a gas estático con asador cm. 67x38x34h, temp: 125÷275°C, con 1 parilla cm.65x36  
**cm. 80x 60x 90h**



⚡ 21 kW  
18.060 kcal/h

**2.996,00**  
95 / 0,62

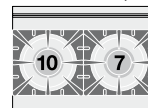

**CF2-68GEM**  
06790861

**CUCINA MISTA 2 FUOCHI CON FORNO ELETTRICO STATICO CON GRILL CM. 67X38X34H, TEMP: 50÷250°C, CON 1 GRIGLIA CM.65X36**

**EN** Combined range static oven - N. 2 burners Static oven cm. 67x38x34h, temp: 50÷250°C, with 1 grid cm.65x36 • **DE** Gemischtherd statischer Ofen - N. 2 Kochstellen Statischer Ofen cm. 67x38x34h, temp: 50÷250°C, mit 1 Rost cm.65x36 • **FR** Cuisinière mixte gaz four estático - N. 2 feux vifs Four statique cm. 67x38x34h, temp: 50÷250°C, avec 1 grille cm.65x36 • **ES** Cocina mixta horno estático - N. 2 quemadores Horno estático cm. 67x38x34h, temp: 50÷250°C, con 1 parilla cm.65x36  
**cm. 80x 60x 90h**



⚡ 17 kW  
14.620 kcal/h

**2.996,00**  
95 / 0,62

⚡ 3,05 kW  
230V~  
50/60 Hz

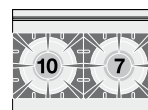

**CFM2-68GEM**  
06790862

**CUCINA MISTA 2 FUOCHI CON FORNO ELETTRICO MULTIFUNZIONE CM. 64X37X35H, TEMP: 50÷250°C, CON 1 GRIGLIA CM.53X32,5 GN1/1 - PORTA VETRO**

**EN** Combined range - N. 2 burners Multifunction electric oven cm. 64x37x35h, temp: 50÷250°C, with 1 grid cm.53x32,5 GN1/1 - Glass door • **DE** Gemischtherd - N. 2 Kochstellen Multifunktions-Elektroofen cm. 64x37x35h, temp: 50÷250°C, mit 1 Rost cm.53x32,5 GN1/1 - Glastür • **FR** Cuisinière mixte - N. 2 feux vifs Four électrique à fonctions multiples cm. 64x37x35h, temp: 50÷250°C, avec 1 grille cm.53x32,5 GN1/1 - Porte acier inoxydable • **ES** Cocina mixta - N. 2 quemadores Horno eléctrico multifuncional cm. 64x37x35h, temp: 50÷250°C, con 1 parilla cm.53x32,5 GN1/1 - Puerta ciega inox  
**cm. 80x 60x 90h**



⚡ 17 kW  
14.620 kcal/h

**3.289,00**  
96 / 0,62

⚡ 3,05 kW  
230V~  
50/60 Hz

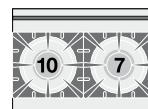

**CFM2-68GEM**  
06790863

**CUCINA MISTA 2 FUOCHI CON FORNO ELETTRICO MULTIFUNZIONE CM. 64X37X35H, TEMP: 50÷250°C, CON 1 GRIGLIA CM.53X32,5 GN1/1 - PORTA CIECA INOX**

**EN** Combined range - N. 2 burners Multifunction electric oven cm. 64x37x35h, temp: 50÷250°C, with 1 grid cm.53x32,5 GN1/1 - Stainless steel door • **DE** Gemischtherd - N. 2 Kochstellen Multifunktions-Elektroofen cm. 64x37x35h, temp: 50÷250°C, mit 1 Rost cm.53x32,5 GN1/1 - Edelstahltür • **FR** Cuisinière mixte - N. 2 feux vifs Four électrique à fonctions multiples cm. 64x37x35h, temp: 50÷250°C, avec 1 grille cm.53x32,5 GN1/1 - Porte acier inoxydable • **ES** Cocina mixta - N. 2 quemadores Horno eléctrico multifuncional cm. 64x37x35h, temp: 50÷250°C, con 1 parilla cm.53x32,5 GN1/1 - Puerta ciega inox  
**cm. 80x 60x 90h**



⚡ 17 kW  
14.620 kcal/h

**3.289,00**  
96 / 0,62

⚡ 3,05 kW  
230V~  
50/60 Hz

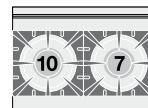

MOD. \_\_\_\_\_  
COD. \_\_\_\_\_

DESCRIZIONE/DESCRIPTION/BEZEICHNUNG/DESCRIPTION/DESCRIPCIÓN  
DIMENSIONI/DIMENSIONS/ABMESSUNGEN/DIMENSIONS/DIMENSIONES

POTENZA/POWER/LEISTUNG/PUISSANCE/POTENCIA  
VOLTAGGIO/VOLTAGE/SPANNUNG/VOLTAGE/VOLTAJE

⚡ kW  
kcal/h

PREZZO/PRICE €  
PREIS/PRIX/PRECIO  
KG / M<sup>3</sup>

**CF3-612GV CUCINA A GAS 3 FUOCHI FORNO A GAS  
STATICO CON GRILL CM. 67X38X34H, TEMP:  
125÷275°C, CON 1 GRIGLIA CM.65X36,  
VANO NEUTRO CON PORTA.**

06781251

**EN** Gas range - N. 3 burners - Gas static oven with grill cm. 67x38x34h, temp: 125÷275°C, with 1 grid cm.65x36 - Neutral cabinet with door • **DE** Gasherd - N. 3 Kochstellen - Gas statischer Backofen mit Grill cm. 67x38x34h, temp: 125÷275°C, mit 1 Rost cm.65x36 - Neutrales Schrankelement mit Tür • **FR** Forneau gaz - N. 3 feux vifs - Four a gaz statique avec grill cm. 67x38x34h, temp: 125÷275°C, avec 1 grille cm.65x36 - Element neutre avec porte • **ES** Cocina gas - N. 3 quemadores Horno a gas estático con asador cm. 67x38x34h, temp: 125÷275°C, con 1 parilla cm.65x36 - Armario neutro con puerta equipado  
**cm. 120x 60x 90h**



⚡ 31 kW  
26.660 kcal/h

**3.671,00**  
102 / 0,92

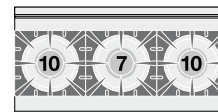

**CF3-612GEMV CUCINA MISTA 3 FUOCHI CON FORNO  
ELETTICO STATICO CON GRILL CM.  
67X38X34H, TEMP: 50÷250°C, CON 1  
GRIGLIA CM.65X36, VANO NEUTRO CON  
PORTA**

06791261

**EN** Combined range static oven - N. 3 burners Static oven cm. 67x38x34h, temp: 50÷250°C, with 1 grid cm.65x36 - Neutral cabinet with door • **DE** Gemischtherd statischer Ofen - N. 3 Kochstellen Statischer Ofen cm. 67x38x34h, temp: 50÷250°C, mit 1 Rost cm.65x36 - Neutrales Schrankelement mit Tür • **FR** Cuisinière mixte gaz four estático - N. 3 feux vifs Four statique cm. 67x38x34h, temp: 50÷250°C, avec 1 grille cm.65x36 - Element neutre avec porte • **ES** Cocina mixta horno estático - N. 3 quemadores Horno estático cm. 67x38x34h, temp: 50÷250°C, con 1 parilla cm.65x36 - Armario neutro con puerta equipado  
**cm. 120x 60x 90h**



⚡ 27 kW  
23.220 kcal/h

**3.671,00**  
102 / 0,92

⚡ 3,05 kW  
230V~  
50/60 Hz

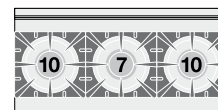

**CFM3-612GEMV CUCINA MISTA 3 FUOCHI CON FORNO  
ELETTICO MULTIFUNZIONE CM. 64X37X35H,  
TEMP: 50÷250°C, CON 1 GRIGLIA  
CM.53X32,5 GN1/1 - PORTA VETRO - VANO  
NEUTRO CON PORTA**

06791262

**EN** Combined range - N. 3 burners Multifunction electric oven cm. 64x37x35h, temp: 50÷250°C, with 1 grid cm.53x32,5 GN1/1 - Glass door - Neutral cabinet with door • **DE** Gemischtherd - N. 3 Kochstellen Multifunktions-Elektroofen cm. 64x37x35h, temp: 50÷250°C, mit 1 Rost cm.53x32,5 GN1/1 - Glastür - Neutrales Schrankelement mit Tür • **FR** Cuisinière mixte - N. 3 feux vifs Four électrique à fonctions multiples cm. 64x37x35h, temp: 50÷250°C, avec 1 grille cm.53x32,5 GN1/1 - Porte acier inoxydable - Element neutre avec porte • **ES** Cocina mixta - N. 3 quemadores Horno eléctrico multifuncional cm. 64x37x35h, temp: 50÷250°C, con 1 parilla cm.53x32,5 GN1/1 - Puerta ciega inox - Armario neutro con puerta equipado  
**cm. 120x 60x 90h**



⚡ 27 kW  
23.220 kcal/h

**3.944,00**  
103 / 0,92

⚡ 3,05 kW  
230V~  
50/60 Hz

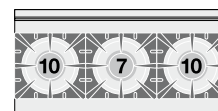

69

# CUCINE A GAS CON FORNO ELETTRICO

MOD. \_\_\_\_\_  
COD. \_\_\_\_\_

DESCRIZIONE/DESCRIPTION/BEZEICHNUNG/DESCRIPTION/DESCRIPCIÓN  
DIMENSIONI/DIMENSIONS/ABMESSUNGEN/DIMENSIONS/DIMENSIONES

POTENZA/POWER/LEISTUNG/PUISSANCE/POTENCIA  
VOLTAGGIO/VOLTAGE/SPANNUNG/VOLTAGE/VOLTAJE

⚡ kW \_\_\_\_\_  
kcal/h \_\_\_\_\_  
⚡ kw \_\_\_\_\_  
V~ \_\_\_\_\_  
Hz \_\_\_\_\_

PREZZO/PRICE € \_\_\_\_\_  
PREIS/PRIX/PRECIO € \_\_\_\_\_  
KG / M<sup>3</sup> \_\_\_\_\_

**CFM3-612GEMV CUCINA MISTA 3 FUOCHI CON FORNO  
ELETTRICO MULTIFUNZIONE CM. 64X37X35H,  
06791263 TEMP: 50÷250°C, CON 1 GRIGLIA  
CM.53X32,5 GN1/1 - PORTA CIECA INOX -  
VANO NEUTRO CON PORTA**

**EN** Combined range - N. 3 burners Multifunction electric oven cm. 64x37x35h, temp: 50÷250°C, with 1 grid cm.53x32,5 GN1/1 - Stainless steel door - Neutral cabinet with door • **DE** Gemischtherd - N. 3 Kochstellen Multifunktions-Elektroofen cm. 64x37x35h, temp: 50÷250°C, mit 1 Rost cm.53x32,5 GN1/1 - Edelstahltür - Neutrales Schrankelement mit Tür • **FR** Cuisinière mixte - N. 3 feux vifs Four électrique à fonctions multiples cm. 64x37x35h, temp: 50÷250°C, avec 1 grille cm.53x32,5 GN1/1 - Porte acier inoxydable - Element neutre avec porte • **ES** Cocina mixta - N. 3 quemadores Horno eléctrico multifuncional cm. 64x37x35h, temp: 50÷250°C, con 1 parilla cm.53x32,5 GN1/1 - Puerta ciega inox - Armario neutro con puerta equipado  
**cm. 120x 60x 90h**



⚡ 27 kW \_\_\_\_\_ **3.944,00**  
23.220 kcal/h \_\_\_\_\_ 103 / 0,92

⚡ 3,05 kW \_\_\_\_\_  
230V~ \_\_\_\_\_  
50/60 Hz \_\_\_\_\_

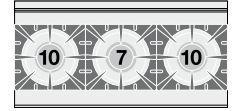

**CPT-64ET CUOCIPASTA TRIFASE LT. 17 VASCA CM.  
16100430 31X33,5X22H. RUBINETTO SCARICO (CESTI  
ESCLUSI)**

**EN** Pasta cooker threephase 17 lts. Tank cm. 31x33,5x22h. Drain-tap (BASKETS EXCLUDED) • **DE** Nudelkocher dreiphasig lt.17 Becken cm. 31x33,5x22h. Ablasshahn (KORB AUSGESCHLOSSEN) • **FR** Cuiseur à pâtes triphase lt.17 Cuve cm. 31x33,5x22h. Robinet de vidange (PANIERS EXCLUS) • **ES** Cuece pasta trifásico lt.17 Cuba cm. 31x33,5x22h. Grifo descarga (CESTAS EXCLUIDAS)  
**cm. 40x 60x 28h**



⚡ 5 kW \_\_\_\_\_ **1.460,00**  
400V~3N \_\_\_\_\_ 27 / 0,18  
230V~ \_\_\_\_\_  
50/60 Hz \_\_\_\_\_

#### COMBINAZIONI

- Combinations / • Zusammenstellungen
- Combinaisons / • Combinación múltiple



**CPT-66ET CUOCIPASTA TRIFASE LT. 25 VASCA CM.  
16100630 51X31X22H. RUBINETTO SCARICO (CESTI  
ESCLUSI)**

**EN** Pasta cooker threephase 25 lts. Tank cm. 51x31x22h. Drain-tap (BASKETS EXCLUDED) • **DE** Nudelkocher dreiphasig lt.25 Becken cm. 51x31x22h. Ablasshahn (KORB AUSGESCHLOSSEN) • **FR** Cuiseur à pâtes triphase lt.25 Cuve cm. 51x31x22h. Robinet de vidange (PANIERS EXCLUS) • **ES** Cuece pasta trifásico lt.25 Cuba cm. 51x31x22h. Grifo descarga (CESTAS EXCLUIDAS)  
**cm. 60x 60x 28h**



⚡ 7,5 kW \_\_\_\_\_ **1.621,00**  
400V~3N \_\_\_\_\_ 42 / 0,27  
50/60 Hz \_\_\_\_\_

#### COMBINAZIONI

- Combinations / • Zusammenstellungen
- Combinaisons / • Combinación múltiple



# CUOCIPASTA A GAS - TOP

MOD. \_\_\_\_\_  
COD. \_\_\_\_\_

DESCRIZIONE/DESCRIPTION/BEZEICHNUNG/DESCRIPTION/DESCRIPCIÓN  
DIMENSIONI/DIMENSIONS/ABMESSUNGEN/DIMENSIONS/DIMENSIONES

POTENZA/POWER/LEISTUNG/PUISSANCE/POTENCIA  
VOLTAGGIO/VOLTAGE/SPANNUNG/VOLTAGE/VOLTAJE

⚡ kW  
kcal/h

PREZZO/PRICE €  
PREIS/PRIX/PRECIO €  
KG / M<sup>3</sup>

**CPT-64G**  
16270450

**CUOCIPASTA A GAS CAPACITA' LT. 13 VASCA CM. 31X33,5X18H. RUBINETTO SCARICO (CESTI ESCLUSI)**

**EN** Gas pasta cookers Tank capacity 13 lts. Tank cm. 31x33,5x18h. Drain-tap (BASKETS EXCLUDED) • **DE** Gas -Nudelkocher Beckeninhalte 13 Becken cm. 31x33,5x18h. Ablasshahn (KORB AUSGESCHLOSSEN) • **FR** Cuiseur à pâtes gaz Cuve lt.13 Cuve cm. 31x33,5x18h. Robinet de vidange (PANIERS EXCLUS) • **ES** Cucece pasta gas Cuba 13 lt. Cuba cm. 31x33,5x18h. Grifo descarga (CESTAS EXCLUIDAS)  
**cm. 40x 60x 28h**



⚡ 6 kW  
5.160 kcal/h

**1.496,00**  
30 / 0,18

**COMBINAZIONI**

- Combinations / • Zusammenstellungen
- Combinaisons / • Combinación múltiple



**CPT-66G**  
16270650

**CUOCIPASTA A GAS CAPACITA' LT. 19 VASCA CM. 51X31X18H. RUBINETTO SCARICO (CESTI ESCLUSI)**

**EN** Gas pasta cookers Tank capacity 19 lts. Tank cm. 51x31x18h. Drain-tap (BASKETS EXCLUDED) • **DE** Gas -Nudelkocher Beckeninhalte 19 Becken cm. 51x31x18h. Ablasshahn (KORB AUSGESCHLOSSEN) • **FR** Cuiseur à pâtes gaz Cuve lt.19 Cuve cm. 51x31x18h. Robinet de vidange (PANIERS EXCLUS) • **ES** Cucece pasta gas Cuba 19 lt. Cuba cm. 51x31x18h. Grifo descarga (CESTAS EXCLUIDAS)  
**cm. 60x 60x 28h**



⚡ 9 kW  
7.740 kcal/h

**1.761,00**  
45 / 0,27

**COMBINAZIONI**

- Combinations / • Zusammenstellungen
- Combinaisons / • Combinación múltiple



**CP-66ET**  
06100630

**CUOCIPASTA TRIFASE LT. 40 VASCA CM. 51X30,7X32,7H. RUBINETTO CARICO ACQUA, SFIORATORE + SCARICO A PAVIMENTO (CESTI ESCLUSI)**

**EN** Pasta cooker threephase 40 lts. - Tank cm. 51x30,7x32,7h. Water loading tap + overflow device and floor draining (BASKETS EXCLUDED) • **DE** Nudelkocher dreiphasig lt. 40 - Becken cm. 51x30,7x32,7h. Wasserlauf-Hahn + Überlauf-Vorrichtung und Ablauf am Boden (KORB AUSGESCHLOSSEN) • **FR** Cuiseur a pâtes triphase lt. 40 - Cuve cm. 51x30,7x32,7h. Robinet d'arrivée d'eau trop plein + système de vidange au sol (PANIERS EXCLUS) • **ES** Cucece pasta trifásico lt. 40 - Cuba cm. 51x30,7x32,7h. Grifo carga agua + vertedero + descarga a pavimento (CESTAS EXCLUIDAS)  
**cm. 60x 60x 90h**



⚡ 13,5 kW  
400V~3N  
50/60 Hz

**2.826,00**  
81 / 0,47

**COMBINAZIONI**

- Combinations / • Zusammenstellungen
- Combinaisons / • Combinación múltiple



60



Le immagini presentate non sono vincolanti. La ditta si riserva di apportare modifiche senza preavviso. • The pictures are purely representative. The manufacturer reserves the right to modify the technical data and models without previous notice. • Les images

LO

présentées ne nous engagent pas. La Société se réserve le droit d'apporter tout modification sans préavis. • Die dargestellten Abbildungen sind nicht verbindlich. Technische Änderungen vorbehalten. • Las imágenes presentadas no son vinculantes. El Fabricante se reserva el derecho de modificar sus productos sin previo aviso.

01/20

37

MOD. \_\_\_\_\_  
COD. \_\_\_\_\_

DESCRIZIONE/DESCRIPTION/BEZEICHNUNG/DESCRIPTION/DESCRIPCIÓN  
DIMENSIONI/DIMENSIONS/ABMESSUNGEN/DIMENSIONS/DIMENSIONES

POTENZA/POWER/LEISTUNG/PUISSANCE/POTENCIA  
VOLTAGGIO/VOLTAGE/SPANNUNG/VOLTAGE/VOLTAJE

⚡ kW kcal/h  
⚡ kW V~ Hz

PREZZO/PRICE €  
PREIS/PRIX/PRECIO €  
KG / M<sup>3</sup>

**CPA-66ET**  
06100635

**CUOCIPASTA TRIFASE LT. 40 VASCA CM. 51X30,7X32,7H. CARICO ACQUA AUTOMATICO CON SENSORE DI LIVELLO - SFIORATORE + SCARICO A PAVIMENTO (CESTI ESCLUSI)**

**EN** Pasta cooker threephase 40 lts. - Tank cm. 51x30,7x32,7h. - Automatic Water loading with level sensor - overflow device and floor draining (BASKETS EXCLUDED) • **DE** Nudelkocher dreiphasig lt. 40 - Becken cm. 51x30,7x32,7h. Automatische Wasser Beladung mit Niveauregulierung + Überlauf-Vorrichtung und Ablauf am Boden (KORB AUSGESCHLOSSEN) • **FR** Cuiseur a pates triphase lt. 40 - Cuve cm. 51x30,7x32,7h. Chargement automatique de l'eau avec sensor de niveau, trop plein Système de vidange au sol (PANIERS EXCLUS) • **ES** Cuece pasta trifásico lt. 40 - Cuba cm. 51x30,7x32,7h. Carga automática de agua con sensor de nivel + vertedero + descarga a pavimento. (CESTAS EXCLUIDAS)  
**cm. 60x 60x 90h**



⚡ 13,5 kW **3.210,00**  
400V~3N 82 / 0,47  
50/60 Hz

**COMBINAZIONI**

- Combinations / • Zusammenstellungen
- Combinaisons / • Combinación múltiple



**CP-66G**  
06270650

**CUOCIPASTA GAS LT. 40 VASCA CM. 51X30,7X32,7H. RUBINETTO CARICO ACQUA, SFIORATORE + SCARICO A PAVIMENTO (CESTI ESCLUSI)**

**EN** Gas pasta cooker on cabinet Tank capacity 40 lts. cm. 51x30,7x32,7h. Water loading tap + overflow device and floor draining (BASKETS EXCLUDED) • **DE** Gas-Nudelkocher Standgerät - Inhalt lt. 40 cm. 51x30,7x32,7h. Wasserlauf-Hahn + Überlauf-Vorrichtung und Ablauf am Boden (KORB AUSGESCHLOSSEN) • **FR** Cuiseur a pates sur coffre gaz - Cuve lt. 40 cm. 51x30,7x32,7h. Robinet d'arrivée d'eau trop plein + système de vidange au sol (PANIERS EXCLUS) • **ES** Cuece pasta gas - Cuba 40 lt. cm. 51x30,7x32,7h. Grifo carga agua + vertedero + descarga a pavimento (CESTAS EXCLUIDAS)  
**cm. 60x 60x 90h**



⚡ 13,95 kW **3.175,00**  
11.997 kcal/h 84 / 0,47  
⚡ 0,02 KW  
230V~  
50/60 Hz

**COMBINAZIONI**

- Combinations / • Zusammenstellungen
- Combinaisons / • Combinación múltiple





# CUOCIPASTA A GAS

MOD. \_\_\_\_\_  
COD. \_\_\_\_\_

DESCRIZIONE/DESCRIPTION/BEZEICHNUNG/DESCRIPTION/DESCRIPCIÓN  
DIMENSIONI/DIMENSIONS/ABMESSUNGEN/DIMENSIONS/DIMENSIONES

POTENZA/POWER/LEISTUNG/PUISSANCE/POTENCIA  
VOLTAGGIO/VOLTAGE/SPANNUNG/VOLTAGE/VOLTAJE

⚡ kW  
kcal/h

⚡ kW  
V~  
Hz

PREZZO/PRICE €  
PREIS/PRIX/PRECIO €  
KG / M<sup>3</sup>

**CPA-66G**  
06270655

**CUOCIPASTA GAS LT. 40 VASCA CM. 51X30,7X32,7H. CARICO ACQUA AUTOMATICO CON SENSORE DI LIVELLO - SFIORATORE + SCARICO A PAVIMENTO (CESTI ESCLUSI)**

**EN** Gas pasta cooker on cabinet Tank capacity 40 lts. cm. 51x30,7x32,7h. Automatic Water loading with level sensor - overflow device and floor draining (BASKETS EXCLUDED) • **DE** Gas-Nudelkocher Standgerät - Inhalt lt. 40 cm. 51x30,7x32,7h. Automatische Wasser Beladung mit Niveauregulierung + Überlauf-Vorrichtung und Ablauf am Boden (KORB AUSGESCHLOSSEN) • **FR** Cuiseur a pates sur coffre gaz - Cuve lt. 40 cm. 51x30,7x32,7h. Chargement automatique de l'eau avec sensor de niveau, trop plein Système de vidange au sol (PANIERS EXCLUS) • **ES** Cuece pasta gas - Cuba 40 lt. cm. 51x30,7x32,7h. Carga automática de agua con sensor de nivel + vertedero + descarga a pavimento. (CESTAS EXCLUIDAS)

**cm. 60x 60x 90h**



⚡ 13,95 kW  
11.997 kcal/h **3.395,00**  
85 / 0,47

⚡ 0,035 kW  
230V~  
50/60 Hz

## COMBINAZIONI

- Combinations / • Zusammenstellungen
- Combinaisons / • Combinación múltiple



**CWKT-64ET**  
16080431

**GRIGLIA CONTACT - COTTURA DIRETTA SU RESISTENZA IN ACCIAIO INOX CM. 27X35 RIBALTABILE**

**EN** CONTACT Grill threephase - Stainless steel grill cm. 27x35 • **DE** Wurstbrater dreiphasig KONTAKT - Einstellbarer Rost aus Nirosta cm. 27x35 • **FR** Grillade triphase CONTACT - Grille inox cm 27x35 • **ES** Parrilla trifásico CONTACT - Parrilla de acero inox regulable cm 27x35

**cm. 40x 60x 28h**



⚡ 3,36 kW **2.175,00**  
400V~3N 35 / 0,18  
50/60 Hz

**CWKT-68ET**  
16080831

**GRIGLIA CONTACT - COTTURA DIRETTA SU RESISTENZA IN ACCIAIO INOX CM. 55X35 RIBALTABILE**

**EN** CONTACT Grill threephase - Stainless steel grill cm. 55x35 • **DE** Wurstbrater dreiphasig KONTAKT - Einstellbarer Rost aus Nirosta cm. 55x35 • **FR** Grillade triphase CONTACT - Grille inox cm 55x35 • **ES** Parrilla trifásico CONTACT - Parrilla de acero inox regulable cm 55x35

**cm. 80x 60x 28h**

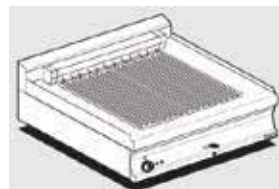

⚡ 6,72 kW **2.924,00**  
400V~3N 50 / 0,35  
50/60 Hz

**CWT-64ET**  
16080430

**GRIGLIA ELETTRICA TRIFASE GRIGLIA IN ACCIAIO INOX CM. 38X42,5 REGOLABILE**

**EN** Grill threephase - Stainless steel grill cm. 38x42,5 • **DE** Wurstbrater dreiphasig Einstellbarer Rost aus Nirosta cm. 38x42,5 • **FR** Grillade Triphase - Grille inox cm. 38x42,5 • **ES** Parrilla trifásico Parrilla de acero inox regulable cm. 38x42,5

**cm. 40x 60x 28h**



⚡ 4,8 kW **1.501,00**  
400V~3N 36 / 0,18  
230V~3  
50/60 Hz

**CWT-66ET**  
16080630

**GRIGLIA ELETTRICA TRIFASE GRIGLIA IN ACCIAIO INOX CM. 58X42,5 REGOLABILE**

**EN** Grill threephase - Stainless steel grill cm. 58x42,5 • **DE** Wurstbrater dreiphasig Einstellbarer Rost aus Nirosta cm. 58x42,5 • **FR** Grillade Triphase - Grille inox cm. 58x42,5 • **ES** Parrilla trifásico Parrilla de acero inox regulable cm. 58x42,5

**cm. 60x 60x 28h**



⚡ 6,3 kW **1.708,00**  
400V~3N 48 / 0,27  
230V~3  
50/60 Hz



Le immagini presentate non sono vincolanti. La ditta si riserva di apportare modifiche senza preavviso. • The pictures are purely representative. The manufacturer reserves the right to modify the technical data and models without previous notice. • Les images

LO

présentées ne nous engagent pas. La Société se réserve le droit d'apporter tout modification sans préavis. • Die dargestellten Abbildungen sind nicht verbindlich. Technische Änderungen vorbehalten. • Las imágenes presentadas no son vinculantes. El Fabricante se reserva el derecho de modificar sus productos sin previo aviso.

01/20

39

# GRIGLIE ELETTRICHE - TOP

MOD. \_\_\_\_\_  
COD. \_\_\_\_\_

DESCRIZIONE/DESCRIPTION/BEZEICHNUNG/DESCRIPTION/DESCRIPCIÓN  
DIMENSIONI/DIMENSIONS/ABMESSUNGEN/DIMENSIONS/DIMENSIONES

POTENZA/POWER/LEISTUNG/PUISSANCE/POTENCIA  
VOLTAGGIO/VOLTAGE/SPANNUNG/VOLTAGE/VOLTAJE

⚡ kW  
kcal/h  
V~  
Hz

PREZZO/PRICE €  
PREIS/PRIX/PRECIO €  
KG / M<sup>3</sup>

**CWT-68ET**  
16080830

**GRIGLIA ELETTRICA TRIFASE N. 2 GRIGLIE IN ACCIAIO INOX CM. 38X42,5 REGOLABILI 2 ZONE DI COTTURA**

**EN** Grill threephase - N. 2 Stainless steel grill cm. 38x42,5 2 cooking areas • **DE** Wurstbrater dreiphasig - N. 2 einstellbarer Rost aus Nirosta cm. 38x42,5 - 2 Heizzonen • **FR** Grillade Triphase - N. 2 grilles réglables en acier inox cm. 38x42,5 - 2 zones de cuisson • **ES** Parrilla trifásico - N. 2 Parrillas de acero inox regulable cm. 38x42,5 - 2 zonas de cocción  
**cm. 80x 60x 28h**



⚡ 9,6 kW  
400V~3N  
230V~3  
50/60 Hz  
**2.323,00**  
52 / 0,35

**CWT-64G**  
16250450

**GRIGLIA A GAS-PIETRALAVICA GRIGLIA IN ACCIAIO INOX CM. 38X42,5 REGOLABILE**

**EN** Charcoal grill gas - Stainless steel grill cm. 38x42,5 • **DE** Gas-Lavasteingrill - Einstellbarer Rost aus Nirosta cm. 38x42,5 • **FR** Grille à gaz en pierre de lave - Grille inox cm. 38x42,5 • **ES** Parrilla a gas piedra lávica Parrilla de acero inox regulable cm. 38x42,5  
**cm. 40x 60x 28h**



⚡ 5,8 kW  
4.988 kcal/h  
**1.598,00**  
41 / 0,18

**CWT-66G**  
16250650

**GRIGLIA A GAS-PIETRALAVICA GRIGLIA IN ACCIAIO INOX CM. 58X42,5 REGOLABILE**

**EN** Charcoal grill gas - Stainless steel grill cm. 58x42,5 • **DE** Gas-Lavasteingrill - Einstellbarer Rost aus Nirosta cm. 58x42,5 • **FR** Grille à gaz en pierre de lave - Grille inox cm. 58x42,5 • **ES** Parrilla a gas piedra lávica Parrilla de acero inox regulable cm. 58x42,5  
**cm. 60x 60x 28h**



⚡ 8,9 kW  
7.654 kcal/h  
**1.916,00**  
58 / 0,27

**CWT-68G**  
16250850

**GRIGLIA A GAS-PIETRALAVICA N. 2 GRIGLIE IN ACCIAIO INOX CM. 38X42,5 REGOLABILI - 2 ZONE DI COTTURA**

**EN** Charcoal grill gas N. 2 Stainless steel grill cm. 38x42,5 - 2 cooking areas • **DE** Gas-Lavasteingrill N. 2 einstellbarer Rost aus Nirosta cm. 38x42,5 - Heizzonen • **FR** Grille à gaz en pierre de lave N. 2 grilles réglables en acier inox cm. 38x42,5 - 2 zones de cuisson • **ES** Parrilla a gas piedra lávica N. 2 Parrillas de acero inox regulable cm. 38x42,5 - 2 zonas de cocción  
**cm. 80x 60x 28h**



⚡ 11,6 kW  
9.976 kcal/h  
**2.574,00**  
62 / 0,35

**F10T-63EM**  
16090310

**FRIGGITRICE ELETTRICA MONOFASE - VASCA LT. 10 CM. 22X35X23H CON FILTRO E COPERCHIO - CESTO CM. 20X30X10H PRODUZIONE PATATE 8 KG/H**

**EN** Fryer singlephase - Tank capacity 10 Lst. cm. 22x35x23h - Sieve and lid for pan - Basket cm. 20x30x10h - Production 8 kg/hr • **DE** Friteuse einphasig - Beckeninhalte lt. 10 cm. 22x35x23h - Einlegesieb und Deckel für Becken - Korb cm. 20x30x10h Pommes frites: 8 kg/pro Stunde • **FR** Friteuse monophasé - Cuve lt. 10 cm. 22x35x23h - Filtre, couvercle pour cuve - Panier 20x30x10h Production de pommes frites: 8 kg/h • **ES** Freidora monofásica - Cuba 10 lt cm. 22x35x23h - Filtro y tapa para cuba - Cesta cm. 20x30x10h Producción patatas 8 kg/h  
**cm. 30x 60x 28h**



⚡ 3,6 kW  
230V~  
50/60 Hz  
**992,00**  
20 / 0,14

# FRIGGITRICI ELETTRICHE - TOP

MOD. \_\_\_\_\_  
COD. \_\_\_\_\_

DESCRIZIONE/DESCRIPTION/BEZEICHNUNG/DESCRIPTION/DESCRIPCIÓN  
DIMENSIONI/DIMENSIONS/ABMESSUNGEN/DIMENSIONS/DIMENSIONES

POTENZA/POWER/LEISTUNG/PUISSANCE/POTENCIA  
VOLTAGGIO/VOLTAGE/SPANNUNG/VOLTAGE/VOLTAJE

⚡ kcal/h  $\frac{kW}{Hz}$

PREZZO/PRICE €  
PREIS/PRIX/PRECIO €  
KG / M<sup>3</sup>

**F10T-63ET**  
16090330

**FRIGGITRICE ELETTRICA TRIFASE - VASCA LT. 10 CM. 22X35X23H CON FILTRO E COPERCHIO - CESTO CM. 20X30X10H PRODUZIONE PATATE 10 KG/H**

EN Fryer threephase - Tank capacity 10 Lst. cm. 22x35x23h - Sieve and lid for pan - Basket cm. 20x30x10h - Production 10 kg/hr • DE Friteuse dreiphasing - Beckeninhalte lt. 10 cm. 22x35x23h - Einlegesieb und Deckel für Becken - Korb cm. 20x30x10h - Pommes frites: 10 kg/pro Stunde • FR Friteuse triphase - Cuve lt. 10 cm. 22x35x23h - Filtre, couvercle pour cuve - Panier 20x30x10h Production de pommes frites: 10 kg/h • ES Freidora Trifásica - Cuba 10 lt cm. 22x35x23h - Filtro y tapa para cuba - Cesta cm. 20x30x10h Producción patatas 10 kg/h  
**cm. 30x 60x 28h**



⚡ 7,15 kW 1.149,00  
400V~3N 21 / 0,14  
230V~3  
50/60 Hz

**F2/10T-66ET**  
16090630

**FRIGGITRICE ELETTRICA TRIFASE - VASCHE LT. 10+10 CM. 22X35X23H CON FILTRO E COPERCHIO - N. 2 CESTI CM. 20X30X10H PRODUZIONE PATATE 20 KG/H**

EN Fryer threephase - Tank capacity 10+10 Lst. cm. 22x35x23h - Sieve and lid for pan - N. 2 baskets cm. 20x30x10h - Production 20 kg/hr • DE Friteuse dreiphasing - Beckeninhalte lt. 10+10cm. 22x35x23h - Einlegesieb und Deckel für Becken - N. 2 Korbe cm. 20x30x10h - Pommes frites: 20 kg/pro Stunde • FR Friteuse triphase - Cuves lt. 10+10 cm. 22x35x23h - Filtre, couvercle pour cuve - N. 2 paniers 20x30x10h Production de pommes frites: 20 kg/h • ES Freidora Trifásica - Cuba 10+10 lt. cm. 22x35x23h - Filtro y tapa para cuba - N. 2 cestas cm. 20x30x10h Producción patatas 20 kg/h  
**cm. 60x 60x 28h**



⚡ 14,3 kW 2.032,00  
400V~3N 37 / 0,27  
230V~3  
50/60 Hz

**F2/10T-66EM**  
16090610

**FRIGGITRICE ELETTRICA MONOFASE - VACHE LT. 10+10 CM. 22X35X23H CON FILTRO E COPERCHIO - N. 2 CESTI CM. 20X30X10H PRODUZIONE PATATE 16 KG/H**

EN Fryer singlephase - Tank capacity 10+10 Lst. cm. 22x35x23h - Sieve and lid for pan - N. 2 baskets cm. 20x30x10h Production 16 kg/hr • DE Friteuse einphasig - Beckeninhalte lt. 10+10cm. 22x35x23h - Einlegesieb und Deckel für Becken - N. 2 Korbe cm. 20x30x10h Pommes frites: 16 kg/pro Stunde • FR Friteuse monophasé - Cuves lt. 10+10 cm. 22x35x23h - Filtre, couvercle pour cuve - N. 2 paniers 20x30x10h Production de pommes frites: 16 kg/h • ES Freidora monofásica - Cuba 10+10 lt. cm. 22x35x23h - Filtro y tapa para cuba - N. 2 cestas cm. 20x30x10h Producción patatas 16 kg/h  
**cm. 60x 60x 28h**

⚡ 7,2 kW 1.722,00  
230V~ 34 / 0,27  
50/60 Hz

**F8T-63G**  
16260350

**FRIGGITRICE A GAS - VASCA LT. 8 CM. 22X27,5X22H - CON FILTRO E COPERCHIO - CESTO 20X24X9H - PRODUZIONE PATATE: 8 KG/H**

EN Gas fryer - Tank capacity 8 lts. cm. 22x27,5x22h - Basket cm. 20x24x9h - Production: 8kg/h • DE Gas-einzelfriteuse - Beckeninhalte lt. 8 cm. 22x27,5x22h - Korb cm. 20x24x9h - Pommes frites: 8 kg/pro Stunde • FR Friteuse gaz - Cuve lt. 8 cm. 22x27,5x22h - Panier 20x24x9h Production de pommes frites: 8 kg/h • ES Freidora gas - Cuba 8 lt. cm. 22x27,5x22h - Cesta cm. 20x24x9h Producción patatas: 8 kg/h  
**cm. 30x 60x 28h**



⚡ 6 kW 1.375,00  
5.160 kcal/h 23 / 0,14



Le immagini presentate non sono vincolanti. La ditta si riserva di apportare modifiche senza preavviso. • The pictures are purely representative. The manufacturer reserves the right to modify the technical data and models without previous notice. • Les images

LO

présentées ne nous engagent pas. La Société se réserve le droit d'apporter tout modification sans préavis. • Die dargestellten Abbildungen sind nicht verbindlich. Technische Änderungen vorbehalten. • Las imágenes presentadas no son vinculantes. El Fabricante se reserva el derecho de modificar sus productos sin previo aviso.

01/20

41

60

# FRIGGITRICI A GAS - TOP

MOD. \_\_\_\_\_  
COD. \_\_\_\_\_

DESCRIZIONE/DESCRIPTION/BEZEICHNUNG/DESCRIPTION/DESCRIPCIÓN  
DIMENSIONI/DIMENSIONS/ABMESSUNGEN/DIMENSIONS/DIMENSIONES

POTENZA/POWER/LEISTUNG/PUISSANCE/POTENCIA  
VOLTAGGIO/VOLTAGE/SPANNUNG/VOLTAGE/VOLTAJE

⚡ kW  
kcal/h

⚡ kW  
V~  
Hz

PREZZO/PRICE €  
PREIS/PRIX/PRECIO €  
KG / M<sup>3</sup>

**F2/8T-66G**  
16260650

**FRIGGITRICE A GAS - VASCHE LT. 8+8 CM. 22X27,5X22H - CON FILTRO E COPERCHIO - N. 2 CESTI 20X24X9H - PRODUZIONE PATATE: 16 KG/H**

EN Gas fryer - Tank capacity 8+8 lts. cm. 22x27,5x22h - N. 2 baskets cm. 20x24x9h Production: 16 kg/h  
• DE Gas-einzelfriteuse - Beckeninhalte lt. 8+8 cm. 22x27,5x22h - N. 2 Korbe cm. 20x24x9h Pommes frites: 16 kg/pro Stunde • FR Friteuse gaz - Cuve lt. 8+8 cm. 22x27,5x22h - N. 2 paniers 20x24x9h - Production de pommes frites: 16 kg/h • ES Freidora gas - Cuba 8+8 lt. cm. 22x27,5x22h - N. 2 cestas cm. 20x24x9h Producción patatas: 16 kg/h  
**cm. 60x 60x 28h**



⚡ 12 kW  
10.320 kcal/h

**2.388,00**  
41 / 0,27

**F13-64ET**  
06090430

**FRIGGITRICE TRIFASE LT. 13 VASCA CM. 24X35X32H - 1 CESTO CM. 21X30X12H - FILTRO E COPERCHIO VASCA. BACINELLA RACCOGLIOLIO CON FILTRO. - PRODUZIONE PATATE: 10 KG/H**

EN Fryer threephase 13 lts - Bowl cm. 24x35x32h - 1 basket cm. 21x30x12h. Sieve and lid for pan. - Drip tray with sieve. Production: 10 kg/h • DE Friteuse dreiphasig lt. 13 - Becken cm. 24x35x32h - 1 Korb cm. 21x30x12h. Einlegesieb und Deckel für Becken. - Fettauffangschale mit Sieb. Pommes frites: 10 kg/h • FR Friteuse triphase lt. 13 - Cuve cm. 24x35x32h - 1 Panier cm. 21x30x12h. Filtre, couvercle pour cuve. - Bac de récupération de l'huile avec filtre. Production de pommes frites: 10 kg/h • ES Freidoras trifásico 13 lt. - Cuba cm. 24x35x32h - 1 cesta cm. 21x30x12h. Filtro y tapa para cuba. Bandeja recoge aceite con filtro. Prod. patatas: 10 Kg/h  
**cm. 40x 60x 90h**



⚡ 11,95 kW  
400V~3N  
50/60 Hz

**1.946,00**  
52 / 0,32

**F13-64G**  
06260450

**FRIGGITRICE GAS LT. 13 VASCA CM. 32,5X31,5X36H - 1 CESTO CM. 30X27,5X12H - FILTRO E COPERCHIO VASCA. BACINELLA RACCOGLIOLIO CON FILTRO. - PRODUZIONE PATATE: 10 KG/H**

EN Gas fryer 13 lts - Bowl cm. 32,5x31,5x36h - 1 basket cm. 30x27,5x12h. Sieve and lid for pan. - Drip tray with sieve. Production: 10 kg/h • DE Gas-Friteuse lt. 13 - Becken cm. 32,5x31,5x36h - 1 Korb cm. 30x27,5x12h. Einlegesieb und Deckel für Becken. - Fettauffangschale mit Sieb. Pommes frites: 10 kg/h • FR Friteuse a gaz lt. 13 - Cuve cm. 32,5x31,5x36h - 1 Panier cm. 30x27,5x12h. Filtre, couvercle pour cuve. - Bac de récupération de l'huile avec filtre. Production de pommes frites: 10 kg/h • ES Freidoras a gas 13 lt. - Cuba cm. 32,5x31,5x36h - 1 cesta cm. 30x27,5x12h. Filtro y tapa para cuba. Bandeja recoge aceite con filtro. Prod. patatas: 10 Kg/h  
**cm. 40x 60x 90h**



⚡ 10,5 kW  
9.020 kcal/h

**2.193,00**  
60 / 0,32

**F1LT-64ET**  
16060431

**FRY-TOP ELETTRICO LISCIO, PIASTRA CM.39,5X45**

EN Electric Fry-top smooth griddle, plate cm.39,5x45  
• DE Griddleplatte elektrische glatt, platte cm.39,5x45  
• FR Plaque électriques lisse, plaque cm.39,5x45 • ES Fry-top eléctrico liso, plancha cm.39,5x45  
**cm. 40x 60x 28h**



⚡ 4,5 kW  
400V~3N  
230V~3  
50/60 Hz

**1.029,00**  
49 / 0,18



# FRY-TOP ELETTRICI - TOP

MOD. \_\_\_\_\_  
COD. \_\_\_\_\_

DESCRIZIONE/DESCRIPTION/BEZEICHNUNG/DESCRIPTION/DESCRIPCIÓN  
DIMENSIONI/DIMENSIONS/ABMESSUNGEN/DIMENSIONS/DIMENSIONES

POTENZA/POWER/LEISTUNG/PUISSANCE/POTENCIA  
VOLTAGGIO/VOLTAGE/SPANNUNG/VOLTAGE/VOLTAJE

⚡ kW kcal/h  
V~ Hz

PREZZO/PRICE €  
PREIS/PRIX/PRECIO €  
KG / M<sup>3</sup>

**FTLT-64ETS**  
16060434

**FRY-TOP ELETTRICO LISCIO CROMATO SUPERCHROME (MOCA APPROVED), PIASTRA CM.39,5X45**  
**EN** Electric Fry-top smooth chromed griddle SUPERCHROME (Moca Approved), plate cm.39,5x45  
• **DE** Griddleplatte elektrische glatt hartverchromt SUPERCHROME (Moca Approved), platte cm.39,5x45  
• **FR** Plaque électriques lisse chromée SUPERCHROME (Moca Approved), plaque cm.39,5x45 • **ES** Fry-top eléctrico liso cromado SUPERCHROME (Moca Approved), plancha cm.39,5x45  
**cm. 40x 60x 28h**



⚡ 4,5 kW **1.412,00**  
400V~3N 49 / 0,18  
230V~3  
50/60 Hz

**FTRT-64ET**  
16060433

**FRY-TOP ELETTRICO RIGATO, PIASTRA CM.39,5X45**  
**EN** Electric Fry-top grooved griddle, plate cm.39,5x45  
• **DE** Griddleplatte elektrische gerillt, platte cm.39,5x45  
• **FR** Plaque électriques nervurée, plaque cm.39,5x45  
• **ES** Fry-top eléctrico estriado, plancha cm.39,5x45  
**cm. 40x 60x 28h**

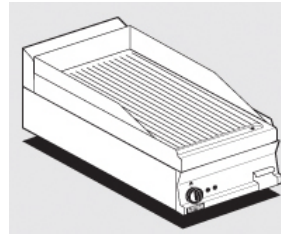

⚡ 4,5 kW **1.181,00**  
400V~3N 49 / 0,18  
230V~3  
50/60 Hz

**FTRT-64ETS**  
16060436

**FRY-TOP ELETTRICO RIGATO CROMATO SUPERCHROME (MOCA APPROVED), PIASTRA CM.39,5X45**  
**EN** Electric Fry-top grooved chromed griddle SUPERCHROME (Moca Approved), plate cm.39,5x45 • **DE** Griddleplatte elektrische gerillt hartverchromt SUPERCHROME (Moca Approved), platte cm.39,5x45 • **FR** Plaque électriques nervurée chromée SUPERCHROME (Moca Approved), plaque cm.39,5x45 • **ES** Fry-top eléctrico estriado cromado SUPERCHROME (Moca Approved), plancha cm.39,5x45  
**cm. 40x 60x 28h**

⚡ 4,5 kW **1.548,00**  
400V~3N 49 / 0,18  
230V~3  
50/60 Hz

**FTLT-66ET**  
16060631

**FRY-TOP ELETTRICO LISCIO, PIASTRA CM.59,5X45 - 2 ZONE DI COTTURA**  
**EN** Electric Fry-top smooth griddle, plate cm.59,5x45 - 2 cooking areas • **DE** Griddleplatte elektrische glatt, platte cm.59,5x45 - 2 Heizzonen • **FR** Plaque électriques lisse, plaque cm.59,5x45 - 2 zones de cuisson • **ES** Fry-top eléctrico liso, plancha cm.59,5x45 - 2 zonas de cocción  
**cm. 60x 60x 28h**



⚡ 6,75 kW **1.350,00**  
400V~3N 66 / 0,27  
230V~3  
230V~  
50/60 Hz

**FTLT-66ETS**  
16060634

**FRY-TOP ELETTRICO LISCIO CROMATO SUPERCHROME (MOCA APPROVED), PIASTRA CM.59,5X45 - 2 ZONE DI COTTURA**  
**EN** Electric Fry-top smooth chromed griddle SUPERCHROME (Moca Approved), plate cm.59,5x45 - 2 cooking areas • **DE** Griddleplatte elektrische glatt hartverchromt SUPERCHROME (Moca Approved), platte cm.59,5x45 - 2 Heizzonen • **FR** Plaque électriques lisse chromée SUPERCHROME (Moca Approved), plaque cm.59,5x45 - 2 zones de cuisson • **ES** Fry-top eléctrico liso cromado SUPERCHROME (Moca Approved), plancha cm.59,5x45 - 2 zonas de cocción  
**cm. 60x 60x 28h**

⚡ 6,75 kW **1.827,00**  
400V~3N 66 / 0,27  
230V~3  
230V~  
50/60 Hz

**FTLRT-66ET**  
16060632

**FRY-TOP ELETTRICO 1/2 RIGATO + 1/2 LISCIO, PIASTRA CM.59,5X45 - 2 ZONE DI COTTURA**  
**EN** Electric Fry-top 1/2 grooved + 1/2 smooth, plate cm.59,5x45 - 2 cooking areas • **DE** Griddleplatte elektrische 1/2 gerillt + 1/2 glatt, platte cm.59,5x45 - 2 Heizzonen • **FR** Plaque électriques 1/2 nervurée + 1/2 lisse, plaque cm.59,5x45 - 2 zones de cuisson • **ES** Fry-top eléctrico 1/2 estriado + 1/2 liso, plancha cm.59,5x45 - 2 zonas de cocción  
**cm. 60x 60x 28h**

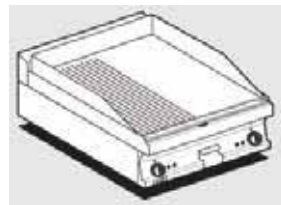

⚡ 6,75 kW **1.470,00**  
400V~3N 66 / 0,27  
230V~3  
230V~  
50/60 Hz



Le immagini presentate non sono vincolanti. La ditta si riserva di apportare modifiche senza preavviso. • The pictures are purely representative. The manufacturer reserves the right to modify the technical data and models without previous notice. • Les images

LO

présentées ne nous engagent pas. La Société se réserve le droit d'apporter tout modification sans préavis. • Die dargestellten Abbildungen sind nicht verbindlich. Technische Änderungen vorbehalten. • Las imágenes presentadas no son vinculantes. El Fabricante se reserva el derecho de modificar sus productos sin previo aviso.

01/20

43

60



# FRY-TOP ELETTRICI - TOP

MOD. \_\_\_\_\_  
COD. \_\_\_\_\_

DESCRIZIONE/DESCRIPTION/BEZEICHNUNG/DESCRIPTION/DESCRIPCIÓN  
DIMENSIONI/DIMENSIONS/ABMESSUNGEN/DIMENSIONS/DIMENSIONES

POTENZA/POWER/LEISTUNG/PUISSANCE/POTENCIA  
VOLTAGGIO/VOLTAGE/SPANNUNG/VOLTAGE/VOLTAJE

⚡ kW kcal/h  
V~ Hz

PREZZO/PRICE €  
PREIS/PRIX/PRECIO  
KG / M<sup>3</sup>

**FTLRT-66ETS FRY-TOP ELETTRICO 1/2 RIGATO + 1/2 LISCIO CROMATO SUPERCHROME (MOCA APPROVED), PIASTRA CM.59,5X45 - 2 ZONE DI COTTURA**

16060635

**EN** Electric Fry-top 1/2 grooved + 1/2 smooth chromed griddle SUPERCHROME (Moca Approved), plate cm.59,5x45 - 2 cooking areas • **DE** Griddleplatte elektrische 1/2 gerillt + 1/2 glatt hartverchromt SUPERCHROME (Moca Approved), platte cm.59,5x45 - 2 Heizzonen • **FR** Plaque électriques 1/2 nervurée + 1/2 lisse chromée SUPERCHROME (Moca Approved), plaque cm.59,5x45 - 2 zones de cuisson • **ES** Fry-top eléctrico 1/2 estriado + 1/2 liso cromado SUPERCHROME (Moca Approved), plancha cm.59,5x45 - 2 zonas de cocción  
**cm. 60x 60x 28h**

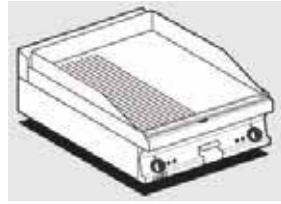

⚡ 6,75 kW 1.953,00  
400V~3N 66 / 0,27  
230V~3  
230V~  
50/60 Hz



**FTRT-66ET FRY-TOP ELETTRICO RIGATO, PIASTRA CM.59,5X45 - 2 ZONE DI COTTURA**

16060633

**EN** Electric Fry-top grooved griddle, plate cm.59,5x45 - 2 cooking areas • **DE** Griddleplatte elektrische gerillt, platte cm.59,5x45 - 2 Heizzonen • **FR** Plaque électriques nervurée, plaque cm.59,5x45 - 2 zones de cuisson • **ES** Fry-top eléctrico estriado, plancha cm.59,5x45 - 2 zonas de cocción  
**cm. 60x 60x 28h**



⚡ 6,75 kW 1.608,00  
400V~3N 66 / 0,27  
230V~3  
230V~  
50/60 Hz



**FTRT-66ETS FRY-TOP ELETTRICO RIGATO CROMATO SUPERCHROME (MOCA APPROVED), PIASTRA CM.59,5X45 - 2 ZONE DI COTTURA**

16060636

**EN** Electric Fry-top grooved chromed griddle SUPERCHROME (Moca Approved), plate cm.59,5x45 - 2 cooking areas • **DE** Griddleplatte elektrische gerillt hartverchromt SUPERCHROME (Moca Approved), platte cm.59,5x45 - 2 Heizzonen • **FR** Plaque électriques nervurée chromée SUPERCHROME (Moca Approved), plaque cm.59,5x45 - 2 zones de cuisson • **ES** Fry-top eléctrico estriado cromado SUPERCHROME (Moca Approved), plancha cm.59,5x45 - 2 zonas de cocción  
**cm. 60x 60x 28h**

⚡ 6,75 kW 2.085,00  
400V~3N 66 / 0,27  
230V~3  
230V~  
50/60 Hz



**FTLT-68ET FRY-TOP ELETTRICO LISCIO, PIASTRA CM.79,5X45 - 2 ZONE DI COTTURA**

16060831

**EN** Electric Fry-top smooth griddle, plate cm.79,5x45 - 2 cooking areas • **DE** Griddleplatte elektrische glatt, platte cm.79,5x45 - 2 Heizzonen • **FR** Plaque électriques lisse, plaque cm.79,5x45 - 2 zones de cuisson • **ES** Fry-top eléctrico liso, plancha cm.79,5x45 - 2 zonas de cocción  
**cm. 80x 60x 28h**

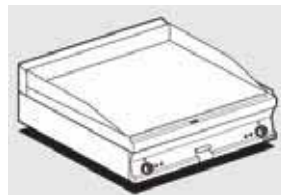

⚡ 9 kW 1.989,00  
400V~3N 81 / 0,35  
230V~3  
50/60 Hz

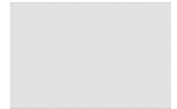

**FTLT-68ETS FRY-TOP ELETTRICO LISCIO CROMATO SUPERCHROME (MOCA APPROVED), PIASTRA CM.79,5X45 - 2 ZONE DI COTTURA**

16060834

**EN** Electric Fry-top smooth chromed griddle SUPERCHROME (Moca Approved), plate cm.79,5x45 - 2 cooking areas • **DE** Griddleplatte elektrische glatt hartverchromt SUPERCHROME (Moca Approved), platte cm.79,5x45 - 2 Heizzonen • **FR** Plaque électriques lisse chromée SUPERCHROME (Moca Approved), plaque cm.79,5x45 - 2 zones de cuisson • **ES** Fry-top eléctrico liso cromado SUPERCHROME (Moca Approved), plancha cm.79,5x45 - 2 zonas de cocción  
**cm. 80x 60x 28h**

⚡ 9 kW 2.439,00  
400V~3N 81 / 0,35  
230V~3  
50/60 Hz

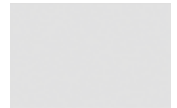

# FRY-TOP ELETTRICI - TOP

MOD. \_\_\_\_\_  
COD. \_\_\_\_\_

DESCRIZIONE/DESCRIPTION/BEZEICHNUNG/DESCRIPTION/DESCRIPCIÓN  
DIMENSIONI/DIMENSIONS/ABMESSUNGEN/DIMENSIONS/DIMENSIONES

POTENZA/POWER/LEISTUNG/PUISSANCE/POTENCIA  
VOLTAGGIO/VOLTAGE/SPANNUNG/VOLTAGE/VOLTAJE

⚡ kW kcal/h  
⚡ kW V~ Hz

PREZZO/PRICE €  
PREIS/PRIX/PRECIO €  
KG / M<sup>3</sup>

**FTLRT-68ET** **FRY-TOP ELETTRICO 1/2 RIGATO + 1/2 LISCIO, PIASTRA CM.79,5X45 - 2 ZONE DI COTTURA**  
16060832  
**EN** Electric Fry-top 1/2 grooved + 1/2 smooth, plate cm.79,5x45 - 2 cooking areas • **DE** Griddleplatte elektrische 1/2 gerillt + 1/2 glatt, platte cm.79,5x45 - 2 Heizzonen • **FR** Plaque électriques 1/2 nervurée + 1/2 lisse, plaque cm.79,5x45 - 2 zones de cuisson • **ES** Fry-top eléctrico 1/2 estriado + 1/2 liso, plancha cm.79,5x45 - 2 zonas de cocción  
**cm. 80x 60x 28h**



⚡ 9 kW **2.116,00**  
400V~3N 81 / 0,35  
230V~3  
50/60 Hz



**FTLRT-68ETS** **FRY-TOP ELETTRICO 1/2 RIGATO + 1/2 LISCIO CROMATO SUPERCHROME (MOCA APPROVED), PIASTRA CM.79,5X45 - 2 ZONE DI COTTURA**  
16060835  
**EN** Electric Fry-top 1/2 grooved + 1/2 smooth chromed griddle SUPERCHROME (Moca Approved), plate cm.79,5x45 - 2 cooking areas • **DE** Griddleplatte elektrische 1/2 gerillt + 1/2 glatt hartverchromt SUPERCHROME (Moca Approved), platte cm.79,5x45 - 2 Heizzonen • **FR** Plaque électriques 1/2 nervurée + 1/2 lisse chromée SUPERCHROME (Moca Approved), plaque cm.79,5x45 - 2 zones de cuisson • **ES** Fry-top eléctrico 1/2 estriado + 1/2 liso cromado SUPERCHROME (Moca Approved), plancha cm.79,5x45 - 2 zonas de cocción  
**cm. 80x 60x 28h**

⚡ 9 kW **2.566,00**  
400V~3N 81 / 0,35  
230V~3  
50/60 Hz



**FTRT-68ET** **FRY-TOP ELETTRICO RIGATO, PIASTRA CM.79,5X45 - 2 ZONE DI COTTURA**  
16060833  
**EN** Electric Fry-top grooved griddle, plate cm.79,5x45 - 2 cooking areas • **DE** Griddleplatte elektrische gerillt, platte cm.79,5x45 - 2 Heizzonen • **FR** Plaque électriques nervurée, plaque cm.79,5x45 - 2 zones de cuisson • **ES** Fry-top eléctrico estriado, plancha cm.79,5x45 - 2 zonas de cocción  
**cm. 80x 60x 28h**

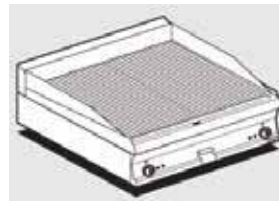

⚡ 9 kW **2.240,00**  
400V~3N 81 / 0,35  
230V~3  
50/60 Hz



**FTRT-68ETS** **FRY-TOP ELETTRICO RIGATO CROMATO SUPERCHROME (MOCA APPROVED), PIASTRA CM.79,5X45 - 2 ZONE DI COTTURA**  
16060836  
**EN** Electric Fry-top grooved chromed griddle SUPERCHROME (Moca Approved), plate cm.79,5x45 - 2 cooking areas • **DE** Griddleplatte elektrische gerillt hartverchromt SUPERCHROME (Moca Approved), platte cm.79,5x45 - 2 Heizzonen • **FR** Plaque électriques nervurée chromée SUPERCHROME (Moca Approved), plaque cm.79,5x45 - 2 zones de cuisson • **ES** Fry-top eléctrico estriado cromado SUPERCHROME (Moca Approved), plancha cm.79,5x45 - 2 zonas de cocción  
**cm. 80x 60x 28h**

⚡ 9 kW **2.694,00**  
400V~3N 81 / 0,35  
230V~3  
50/60 Hz



**FTLT-610ET** **FRY-TOP ELETTRICO LISCIO, PIASTRA CM.99,5X45 - 2 ZONE DI COTTURA**  
16061031  
**EN** Electric Fry-top smooth griddle, plate cm.99,5x45 - 2 cooking areas • **DE** Griddleplatte elektrische glatt, platte cm.99,5x45 - 2 Heizzonen • **FR** Plaque électriques lisse, plaque cm.99,5x45 - 2 zones de cuisson • **ES** Fry-top eléctrico liso, plancha cm.99,5x45 - 2 zonas de cocción  
**cm. 100x 60x 28h**



⚡ 11,25 kW **2.263,00**  
400V~3N 88 / 0,43  
50/60 Hz



60



Le immagini presentate non sono vincolanti. La ditta si riserva di apportare modifiche senza preavviso. • The pictures are purely representative. The manufacturer reserves the right to modify the technical data and models without previous notice. • Les images

LO

présentées ne nous engagent pas. La Société se réserve le droit d'apporter tout modification sans préavis. • Die dargestellten Abbildungen sind nicht verbindlich. Technische Änderungen vorbehalten. • Las imágenes presentadas no son vinculantes. El Fabricante se reserva el derecho de modificar sus productos sin previo aviso.

01/20

45

# FRY-TOP ELETTRICI - TOP

MOD. \_\_\_\_\_  
COD. \_\_\_\_\_

DESCRIZIONE/DESCRIPTION/BEZEICHNUNG/DESCRIPTION/DESCRIPCIÓN  
DIMENSIONI/DIMENSIONS/ABMESSUNGEN/DIMENSIONS/DIMENSIONES

POTENZA/POWER/LEISTUNG/PUISSANCE/POTENCIA  
VOLTAGGIO/VOLTAGE/SPANNUNG/VOLTAGE/VOLTAJE

⚡ kW  
400V~3N  
50/60 Hz

PREZZO/PRICE €  
PREIS/PRIX/PRECIO €  
KG / M<sup>3</sup>

**FTLT-610ETS FRY-TOP ELETTRICO LISCIO CROMATO SUPERCHROME (MOCA APPROVED), PIASTRA CM.99,5X45 - 2 ZONE DI COTTURA**  
16061034  
**EN** Electric Fry-top smooth chromed griddle SUPERCHROME (Moca Approved), plate cm.99,5x45 - 2 cooking areas • **DE** Griddleplatte elektrische glatt hartverchromt SUPERCHROME (Moca Approved), platte cm.99,5x45 - 2 Heizzonen • **FR** Plaque électriques lisse chromée SUPERCHROME (Moca Approved), plaque cm.99,5x45 - 2 zones de cuisson • **ES** Fry-top eléctrico liso cromado SUPERCHROME (Moca Approved), plancha cm.99,5x45 - 2 zonas de cocción  
**cm. 100x 60x 28h**



⚡ 11,25 kW **2.695,00**  
400V~3N 88 / 0,43  
50/60 Hz

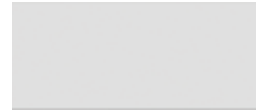

**FTLRT-610ET FRY-TOP ELETTRICO 2/5 RIGATO + 3/5 LISCIO, PIASTRA CM.99,5X45 - 2 ZONE DI COTTURA**  
16061032  
**EN** Electric Fry-top 2/5 grooved + 3/5 smooth, plate cm.99,5x45 - 2 cooking areas • **DE** Griddleplatte elektrische 2/5 gerillt + 3/5 glatt, platte cm.99,5x45 - 2 Heizzonen • **FR** Plaque électriques 2/5 nervurée + 3/5 lisse, plaque cm.99,5x45 - 2 zones de cuisson • **ES** Fry-top eléctrico 2/5 estriado + 3/5 liso, plancha cm.99,5x45 - 2 zonas de cocción  
**cm. 100x 60x 28h**



⚡ 11,25 kW **2.400,00**  
400V~3N 88 / 0,43  
50/60 Hz



**FTLRT-610ETS FRY-TOP ELETTRICO 2/5 RIGATO + 3/5 LISCIO CROMATO SUPERCHROME (MOCA APPROVED), PIASTRA CM.99,5X45 - 2 ZONE DI COTTURA**  
16061035  
**EN** Electric Fry-top 2/5 grooved + 3/5 smooth chromed griddle SUPERCHROME (Moca Approved), plate cm.99,5x45 - 2 cooking areas • **DE** Griddleplatte elektrische 2/5 gerillt + 3/5 glatt hartverchromt SUPERCHROME (Moca Approved), platte cm.99,5x45 - 2 Heizzonen • **FR** Plaque électriques 2/5 nervurée + 3/5 lisse chromée SUPERCHROME (Moca Approved), plaque cm.99,5x45 - 2 zones de cuisson • **ES** Fry-top eléctrico 2/5 estriado + 3/5 liso cromado SUPERCHROME (Moca Approved), plancha cm.99,5x45 - 2 zonas de cocción  
**cm. 100x 60x 28h**

⚡ 11,25 kW **2.822,00**  
400V~3N 88 / 0,43  
50/60 Hz



**FTRT-610ET FRY-TOP ELETTRICO RIGATO, PIASTRA CM.99,5X45 - 2 ZONE DI COTTURA**  
16061033  
**EN** Electric Fry-top grooved griddle, plate cm.99,5x45 - 2 cooking areas • **DE** Griddleplatte elektrische gerillt, platte cm.99,5x45 - 2 Heizzonen • **FR** Plaque électriques nervurée, plaque cm.99,5x45 - 2 zones de cuisson • **ES** Fry-top eléctrico estriado, plancha cm.99,5x45 - 2 zonas de cocción  
**cm. 100x 60x 28h**



⚡ 11,25 kW **2.536,00**  
400V~3N 88 / 0,43  
50/60 Hz



**FTRT-610ETS FRY-TOP ELETTRICO RIGATO CROMATO SUPERCHROME (MOCA APPROVED), PIASTRA CM.99,5X45 - 2 ZONE DI COTTURA**  
16061036  
**EN** Electric Fry-top grooved chromed griddle SUPERCHROME (Moca Approved), plate cm.99,5x45 - 2 cooking areas • **DE** Griddleplatte elektrische gerillt hartverchromt SUPERCHROME (Moca Approved), platte cm.99,5x45 - 2 Heizzonen • **FR** Plaque électriques nervurée chromée SUPERCHROME (Moca Approved), plaque cm.99,5x45 - 2 zones de cuisson • **ES** Fry-top eléctrico estriado cromado SUPERCHROME (Moca Approved), plancha cm.99,5x45 - 2 zonas de cocción  
**cm. 100x 60x 28h**

⚡ 11,25 kW **2.962,00**  
400V~3N 88 / 0,43  
50/60 Hz



# FRY-TOP A GAS - TOP

MOD. \_\_\_\_\_  
COD. \_\_\_\_\_

DESCRIZIONE/DESCRIPTION/BEZEICHNUNG/DESCRIPTION/DESCRIPCIÓN  
DIMENSIONI/DIMENSIONS/ABMESSUNGEN/DIMENSIONS/DIMENSIONES

POTENZA/POWER/LEISTUNG/PUISSANCE/POTENCIA  
VOLTAGGIO/VOLTAGE/SPANNUNG/VOLTAGE/VOLTAJE

6 kW  
5.160 kcal/h

PREZZO/PRICE €  
PREIS/PRIX/PRECIO €  
KG / M<sup>3</sup>

**FTLT-64G**  
16230451

**FRY-TOP GAS LISCIO, PIASTRA CM.39,5X45**  
**EN** Gas Fry-top smooth griddle, plate cm.39,5x45  
• **DE** Gas-griddleplatte glatt, platte cm.39,5x45 • **FR** Plaque gaz lisse, plaque cm.39,5x45 • **ES** Fry-top gas liso, plancha cm.39,5x45  
**cm. 40x 60x 28h**



6 kW  
5.160 kcal/h

**1.105,00**  
47 / 0,18

**FTLT-64GS**  
16230454

**FRY-TOP GAS LISCIO CROMATO SUPERCHROME (MOCA APPROVED), PIASTRA CM.39,5X45**  
**EN** Gas Fry-top smooth chromed griddle SUPERCHROME (Moca Approved), plate cm.39,5x45  
• **DE** Gas-griddleplatte glatt hartverchromt SUPERCHROME (Moca Approved), platte cm.39,5x45  
• **FR** Plaque gaz lisse chromée SUPERCHROME (Moca Approved), plaque cm.39,5x45 • **ES** Fry-top gas liso cromado SUPERCHROME (Moca Approved), plancha cm.39,5x45  
**cm. 40x 60x 28h**

6 kW  
5.160 kcal/h

**1.468,00**  
47 / 0,18

**FVRT-64G**  
16230453

**FRY-TOP GAS RIGATO, PIASTRA CM.39,5X45**  
**EN** Gas Fry-top grooved griddle, plate cm.39,5x45  
• **DE** Gas-griddleplatte gerillt, platte cm.39,5x45 • **FR** Plaque gaz nervurée, plaque cm.39,5x45 • **ES** Fry-top gas estriado, plancha cm.39,5x45  
**cm. 40x 60x 28h**

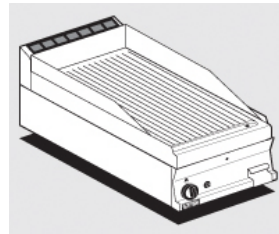

6 kW  
5.160 kcal/h

**1.209,00**  
47 / 0,18

**FVRT-64GS**  
16230456

**FRY-TOP GAS RIGATO CROMATO SUPERCHROME (MOCA APPROVED), PIASTRA CM.39,5X45**  
**EN** Gas Fry-top grooved chromed griddle SUPERCHROME (Moca Approved), plate cm.39,5x45  
• **DE** Gas-griddleplatte gerillt hartverchromt SUPERCHROME (Moca Approved), platte cm.39,5x45  
• **FR** Plaque gaz nervurée chromée SUPERCHROME (Moca Approved), plaque cm.39,5x45 • **ES** Fry-top gas estriado cromado SUPERCHROME (Moca Approved), plancha cm.39,5x45  
**cm. 40x 60x 28h**

6 kW  
5.160 kcal/h

**1.618,00**  
47 / 0,18

**FTLT-66G**  
16230651

**FRY-TOP GAS LISCIO, PIASTRA CM.59,5X45 - 2 ZONE DI COTTURA**  
**EN** Gas Fry-top smooth griddle, plate cm.59,5x45 - 2 cooking areas • **DE** Gas-griddleplatte glatt, platte cm.59,5x45 - 2 Heizzonen • **FR** Plaque gaz lisse, plaque cm.59,5x45 - 2 zones de cuisson • **ES** Fry-top gas liso, plancha cm.59,5x45 - 2 zonas de cocción  
**cm. 60x 60x 28h**

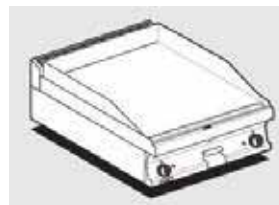

9 kW  
7.740 kcal/h

**1.575,00**  
65 / 0,27

**FTLT-66GS**  
16230654

**FRY-TOP GAS LISCIO CROMATO SUPERCHROME (MOCA APPROVED), PIASTRA CM.59,5X45 - 2 ZONE DI COTTURA**  
**EN** Gas Fry-top smooth chromed griddle SUPERCHROME (Moca Approved), plate cm.59,5x45 - 2 cooking areas • **DE** Gas-griddleplatte glatt hartverchromt SUPERCHROME (Moca Approved), platte cm.59,5x45 - 2 Heizzonen • **FR** Plaque gaz lisse chromée SUPERCHROME (Moca Approved), plaque cm.59,5x45 - 2 zones de cuisson • **ES** Fry-top gas liso cromado SUPERCHROME (Moca Approved), plancha cm.59,5x45 - 2 zonas de cocción  
**cm. 60x 60x 28h**

9 kW  
7.740 kcal/h

**1.895,00**  
65 / 0,27

60



Le immagini presentate non sono vincolanti. La ditta si riserva di apportare modifiche senza preavviso. • The pictures are purely representative. The manufacturer reserves the right to modify the technical data and models without previous notice. • Les images

LO

présentées ne nous engagent pas. La Société se réserve le droit d'apporter tout modification sans préavis. • Die dargestellten Abbildungen sind nicht verbindlich. Technische Änderungen vorbehalten. • Las imágenes presentadas no son vinculantes. El Fabricante se reserva el derecho de modificar sus productos sin previo aviso.

01/20

47



# FRY-TOP A GAS - TOP

MOD. \_\_\_\_\_  
COD. \_\_\_\_\_

DESCRIZIONE/DESCRIPTION/BEZEICHNUNG/DESCRIPTION/DESCRIPCIÓN  
DIMENSIONI/DIMENSIONS/ABMESSUNGEN/DIMENSIONS/DIMENSIONES

POTENZA/POWER/LEISTUNG/PUISSANCE/POTENCIA  
VOLTAGGIO/VOLTAGE/SPANNUNG/VOLTAGE/VOLTAJE

9 kW  
7.740 kcal/h

PREZZO/PRICE €  
PREIS/PRIX/PRECIO €  
KG / M<sup>3</sup>

**FRLRT-66G**  
16230652

**FRY-TOP GAS 1/2 RIGATO + 1/2 LISCIO, PIASTRA CM.59,5X45 - 2 ZONE DI COTTURA**  
EN Gas Fry-top 1/2 grooved + 1/2 smooth, plate cm.59,5x45 - 2 cooking areas • DE Gas-griddleplatte 1/2 gerillt + 1/2 glatt, platte cm.59,5x45 - 2 Heizzonen • FR Plaque gaz 1/2 nervurée + 1/2 lisse, plaque cm.59,5x45 - 2 zones de cuisson • ES Fry-top gas 1/2 estriado + 1/2 liso, plancha cm.59,5x45 - 2 zonas de cocción  
**cm. 60x 60x 28h**



9 kW  
7.740 kcal/h

**1.692,00**  
65 / 0,27



**FRLRT-66GS**  
16230655

**FRY-TOP GAS 1/2 RIGATO + 1/2 LISCIO CROMATO SUPERCHROME (MOCA APPROVED), PIASTRA CM.59,5X45 - 2 ZONE DI COTTURA**  
EN Gas Fry-top 1/2 grooved + 1/2 smooth chromed griddle SUPERCHROME (Moca Approved), plate cm.59,5x45 - 2 cooking areas • DE Gas-griddleplatte 1/2 gerillt + 1/2 glatt hartverchromt SUPERCHROME (Moca Approved), platte cm.59,5x45 - 2 Heizzonen • FR Plaque gaz 1/2 nervurée + 1/2 lisse chromée SUPERCHROME (Moca Approved), plaque cm.59,5x45 - 2 zones de cuisson • ES Fry-top gas 1/2 estriado + 1/2 liso cromado SUPERCHROME (Moca Approved), plancha cm.59,5x45 - 2 zonas de cocción  
**cm. 60x 60x 28h**

9 kW  
7.740 kcal/h

**1.940,00**  
65 / 0,27



**FRT-66G**  
16230653

**FRY-TOP GAS RIGATO, PIASTRA CM.59,5X45 - 2 ZONE DI COTTURA**  
EN Gas Fry-top grooved griddle, plate cm.59,5x45 - 2 cooking areas • DE Gas-griddleplatte gerillt, platte cm.59,5x45 - 2 Heizzonen • FR Plaque gaz nervurée, plaque cm.59,5x45 - 2 zones de cuisson • ES Fry-top gas estriado, plancha cm.59,5x45 - 2 zonas de cocción  
**cm. 60x 60x 28h**



9 kW  
7.740 kcal/h

**1.810,00**  
65 / 0,27



**FRT-66GS**  
16230656

**FRY-TOP GAS RIGATO CROMATO SUPERCHROME (MOCA APPROVED), PIASTRA CM.59,5X45 - 2 ZONE DI COTTURA**  
EN Gas Fry-top grooved chromed griddle SUPERCHROME (Moca Approved), plate cm.59,5x45 - 2 cooking areas • DE Gas-griddleplatte gerillt hartverchromt SUPERCHROME (Moca Approved), platte cm.59,5x45 - 2 Heizzonen • FR Plaque gaz nervurée chromée SUPERCHROME (Moca Approved), plaque cm.59,5x45 - 2 zones de cuisson • ES Fry-top gas estriado cromado SUPERCHROME (Moca Approved), plancha cm.59,5x45 - 2 zonas de cocción  
**cm. 60x 60x 28h**

9 kW  
7.740 kcal/h

**2.034,00**  
65 / 0,27



**FRLT-68G**  
16230851

**FRY-TOP GAS LISCIO, PIASTRA CM.79,5X45 - 2 ZONE DI COTTURA**  
EN Gas Fry-top smooth griddle, plate cm.79,5x45 - 2 cooking areas • DE Gas-griddleplatte glatt, platte cm.79,5x45 - 2 Heizzonen • FR Plaque gaz lisse, plaque cm.79,5x45 - 2 zones de cuisson • ES Fry-top gas liso, plancha cm.79,5x45 - 2 zonas de cocción  
**cm. 80x 60x 28h**

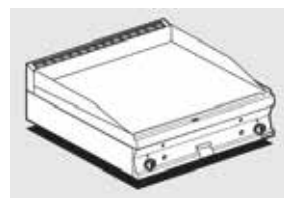

12 kW  
10.320 kcal/h

**2.177,00**  
83 / 0,35

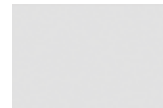



# FRY-TOP A GAS - TOP

MOD. \_\_\_\_\_  
COD. \_\_\_\_\_

DESCRIZIONE/DESCRIPTION/BEZEICHNUNG/DESCRIPTION/DESCRIPCIÓN  
DIMENSIONI/DIMENSIONS/ABMESSUNGEN/DIMENSIONS/DIMENSIONES

POTENZA/POWER/LEISTUNG/PUISSANCE/POTENCIA  
VOLTAGGIO/VOLTAGE/SPANNUNG/VOLTAGE/VOLTAJE

12 kW  
10.320 kcal/h

PREZZO/PRICE €  
PREIS/PRIX/PRECIO €  
KG / M<sup>3</sup>

**FTLT-68GS**  
16230854

**FRY-TOP GAS LISCIO CROMATO SUPERCHROME (MOCA APPROVED), PIASTRA CM.79,5X45 - 2 ZONE DI COTTURA**  
**EN** Gas Fry-top smooth chromed griddle SUPERCHROME (Moca Approved), plate cm.79,5x45 - 2 cooking areas • **DE** Gas-griddleplatte glatt hartverchromt SUPERCHROME (Moca Approved), platte cm.79,5x45 - 2 Heizzonen • **FR** Plaque gaz lisse chromée SUPERCHROME (Moca Approved), plaque cm.79,5x45 - 2 zones de cuisson • **ES** Fry-top gas liso cromado SUPERCHROME (Moca Approved), plancha cm.79,5x45 - 2 zonas de cocción  
**cm. 80x 60x 28h**

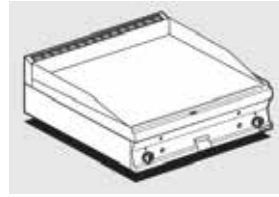

12 kW  
10.320 kcal/h

**2.589,00**  
83 / 0,35

**FRLT-68G**  
16230852

**FRY-TOP GAS 1/2 RIGATO + 1/2 LISCIO, PIASTRA CM.79,5X45 - 2 ZONE DI COTTURA**  
**EN** Gas Fry-top 1/2 grooved + 1/2 smooth, plate cm.79,5x45 - 2 cooking areas • **DE** Gas-griddleplatte 1/2 gerillt + 1/2 glatt, platte cm.79,5x45 - 2 Heizzonen • **FR** Plaque gaz 1/2 nervurée + 1/2 lisse, plaque cm.79,5x45 - 2 zones de cuisson • **ES** Fry-top gas 1/2 estriado + 1/2 liso, plancha cm.79,5x45 - 2 zonas de cocción  
**cm. 80x 60x 28h**



12 kW  
10.320 kcal/h

**2.256,00**  
83 / 0,35

**FRLT-68GS**  
16230855

**FRY-TOP GAS 1/2 RIGATO + 1/2 LISCIO CROMATO SUPERCHROME (MOCA APPROVED), PIASTRA CM.79,5X45 - 2 ZONE DI COTTURA**  
**EN** Gas Fry-top 1/2 grooved + 1/2 smooth chromed griddle SUPERCHROME (Moca Approved), plate cm.79,5x45 - 2 cooking areas • **DE** Gas-griddleplatte 1/2 gerillt + 1/2 glatt hartverchromt SUPERCHROME (Moca Approved), platte cm.79,5x45 - 2 Heizzonen • **FR** Plaque gaz 1/2 nervurée + 1/2 lisse chromée SUPERCHROME (Moca Approved), plaque cm.79,5x45 - 2 zones de cuisson • **ES** Fry-top gas 1/2 estriado + 1/2 liso cromado SUPERCHROME (Moca Approved), plancha cm.79,5x45 - 2 zonas de cocción  
**cm. 80x 60x 28h**



12 kW  
10.320 kcal/h

**2.650,00**  
83 / 0,35

**FVRT-68G**  
16230853

**FRY-TOP GAS RIGATO, PIASTRA CM.79,5X45 - 2 ZONE DI COTTURA**  
**EN** Gas Fry-top grooved griddle, plate cm.79,5x45 - 2 cooking areas • **DE** Gas-griddleplatte gerillt, platte cm.79,5x45 - 2 Heizzonen • **FR** Plaque gaz nervurée, plaque cm.79,5x45 - 2 zones de cuisson • **ES** Fry-top gas estriado, plancha cm.79,5x45 - 2 zonas de cocción  
**cm. 80x 60x 28h**

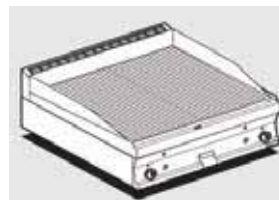

12 kW  
10.320 kcal/h

**2.400,00**  
83 / 0,35

**FVRT-68GS**  
16230856

**FRY-TOP GAS RIGATO CROMATO SUPERCHROME (MOCA APPROVED), PIASTRA CM.79,5X45 - 2 ZONE DI COTTURA**  
**EN** Gas Fry-top grooved chromed griddle SUPERCHROME (Moca Approved), plate cm.79,5x45 - 2 cooking areas • **DE** Gas-griddleplatte gerillt hartverchromt SUPERCHROME (Moca Approved), platte cm.79,5x45 - 2 Heizzonen • **FR** Plaque gaz nervurée chromée SUPERCHROME (Moca Approved), plaque cm.79,5x45 - 2 zones de cuisson • **ES** Fry-top gas estriado cromado SUPERCHROME (Moca Approved), plancha cm.79,5x45 - 2 zonas de cocción  
**cm. 80x 60x 28h**



12 kW  
10.320 kcal/h

**2.793,00**  
83 / 0,35

69



Le immagini presentate non sono vincolanti. La ditta si riserva di apportare modifiche senza preavviso. • The pictures are purely representative. The manufacturer reserves the right to modify the technical data and models without previous notice. • Les images

LO

présentées ne nous engagent pas. La Société se réserve le droit d'apporter tout modification sans préavis. • Die dargestellten Abbildungen sind nicht verbindlich. Technische Änderungen vorbehalten. • Las imágenes presentadas no son vinculantes. El Fabricante se reserva el derecho de modificar sus productos sin previo aviso.

01/20

49

# FRY-TOP A GAS - TOP

MOD. \_\_\_\_\_  
COD. \_\_\_\_\_

DESCRIZIONE/DESCRIPTION/BEZEICHNUNG/DESCRIPTION/DESCRIPCIÓN  
DIMENSIONI/DIMENSIONS/ABMESSUNGEN/DIMENSIONS/DIMENSIONES

POTENZA/POWER/LEISTUNG/PUISSANCE/POTENCIA  
VOLTAGGIO/VOLTAGE/SPANNUNG/VOLTAGE/VOLTAJE

15 kW  
12.900 kcal/h

PREZZO/PRICE €  
PREIS/PRIX/PRECIO €  
KG / M<sup>3</sup>

**FTLT-610G** **FRY-TOP GAS LISCIO, PIASTRA CM.99,5X45 - 2 ZONE DI COTTURA**  
16231051

**EN** Gas Fry-top smooth griddle, plate cm.99,5x45 - 2 cooking areas • **DE** Gas-griddleplatte glatt, platte cm.99,5x45 - 2 Heizzonen • **FR** Plaque gaz lisse, plaque cm.99,5x45 - 2 zones de cuisson • **ES** Fry-top gas liso, plancha cm.99,5x45 - 2 zonas de cocción  
**cm. 100x 60x 28h**



15 kW  
12.900 kcal/h

**2.491,00**  
89 / 0,43

**FTLT-610GS** **FRY-TOP GAS LISCIO CROMATO SUPERCHROME (MOCA APPROVED), PIASTRA CM.99,5X45 - 2 ZONE DI COTTURA**  
16231054

**EN** Gas Fry-top smooth chromed griddle SUPERCHROME (Moca Approved), plate cm.99,5x45 - 2 cooking areas • **DE** Gas-griddleplatte glatt hartverchromt SUPERCHROME (Moca Approved), platte cm.99,5x45 - 2 Heizzonen • **FR** Plaque gaz lisse chromée SUPERCHROME (Moca Approved), plaque cm.99,5x45 - 2 zones de cuisson • **ES** Fry-top gas liso cromado SUPERCHROME (Moca Approved), plancha cm.99,5x45 - 2 zonas de cocción  
**cm. 100x 60x 28h**

15 kW  
12.900 kcal/h

**2.906,00**  
89 / 0,43

**FTLRT-610G** **FRY-TOP GAS 2/5 RIGATO + 3/5 LISCIO, PIASTRA CM.99,5X45 - 2 ZONE DI COTTURA**  
16231052

**EN** Gas Fry-top 2/5 grooved + 3/5 smooth, plate cm.99,5x45 - 2 cooking areas • **DE** Gas-griddleplatte 2/5 gerillt + 3/5 glatt, platte cm.99,5x45 - 2 Heizzonen • **FR** Plaque gaz 2/5 nervurée + 3/5 lisse, plaque cm.99,5x45 - 2 zones de cuisson • **ES** Fry-top gas 2/5 estriado + 3/5 liso, plancha cm.99,5x45 - 2 zonas de cocción  
**cm. 100x 60x 28h**



15 kW  
12.900 kcal/h

**2.628,00**  
89 / 0,43

**FTLRT-610GS** **FRY-TOP GAS 2/5 RIGATO + 3/5 LISCIO CROMATO SUPERCHROME (MOCA APPROVED), PIASTRA CM.99,5X45 - 2 ZONE DI COTTURA**  
16231055

**EN** Gas Fry-top 2/5 grooved + 3/5 smooth chromed griddle SUPERCHROME (Moca Approved), plate cm.99,5x45 - 2 cooking areas • **DE** Gas-griddleplatte 2/5 gerillt + 3/5 glatt hartverchromt SUPERCHROME (Moca Approved), platte cm.99,5x45 - 2 Heizzonen • **FR** Plaque gaz 2/5 nervurée + 3/5 lisse chromée SUPERCHROME (Moca Approved), plaque cm.99,5x45 - 2 zones de cuisson • **ES** Fry-top gas 2/5 estriado + 3/5 liso cromado SUPERCHROME (Moca Approved), plancha cm.99,5x45 - 2 zonas de cocción  
**cm. 100x 60x 28h**

15 kW  
12.900 kcal/h

**3.031,00**  
89 / 0,43

**FTRT-610G** **FRY-TOP GAS RIGATO, PIASTRA CM.99,5X45 - 2 ZONE DI COTTURA**  
16231053

**EN** Gas Fry-top grooved griddle, plate cm.99,5x45 - 2 cooking areas • **DE** Gas-griddleplatte gerillt, platte cm.99,5x45 - 2 Heizzonen • **FR** Plaque gaz nervurée, plaque cm.99,5x45 - 2 zones de cuisson • **ES** Fry-top gas estriado, plancha cm.99,5x45 - 2 zonas de cocción  
**cm. 100x 60x 28h**



15 kW  
12.900 kcal/h

**2.868,00**  
89 / 0,43

# FRY-TOP A GAS - TOP

MOD. \_\_\_\_\_  
COD. \_\_\_\_\_

DESCRIZIONE/DESCRIPTION/BEZEICHNUNG/DESCRIPTION/DESCRIPCIÓN  
DIMENSIONI/DIMENSIONS/ABMESSUNGEN/DIMENSIONS/DIMENSIONES

POTENZA/POWER/LEISTUNG/PUISSANCE/POTENCIA  
VOLTAGGIO/VOLTAGE/SPANNUNG/VOLTAGE/VOLTAJE

$\frac{kW}{kcal/h}$   $\frac{V}{Hz}$

PREZZO/PRICE €  
PREIS/PRIX/PRECIO €  
KG / M<sup>3</sup>

**FTRT-610GS FRY-TOP GAS RIGATO CROMATO SUPERCHROME (MOCA APPROVED), PIASTRA CM.99,5X45 - 2 ZONE DI COTTURA**  
16231056  
**EN** Gas Fry-top grooved chromed griddle SUPERCHROME (Moca Approved), plate cm.99,5x45 - 2 cooking areas • **DE** Gas-griddleplatte gerillt hartverchromt SUPERCHROME (Moca Approved), platte cm.99,5x45 - 2 Heizzonen • **FR** Plaque gaz nervurée chromée SUPERCHROME (Moca Approved), plaque cm.99,5x45 - 2 zones de cuisson • **ES** Fry-top gas estriado cromado SUPERCHROME (Moca Approved), plancha cm.99,5x45 - 2 zonas de cocción  
**cm. 100x 60x 28h**



$\frac{15 kW}{12.900 kcal/h}$  **3.158,00**  
89 / 0,43



**RSFT-63EM PIASTRA PER SANDWICH SOPRA FRYTOP ELETTRICI - PIASTRA CM. 29X40 (ATTENZIONE: PROFONDITA' MACCHINA +CM.10)**  
16630317  
**EN** Sandwiches plate above electric griddle - plate cm. 29x40 (ATTENTION: DEPTH MACHINE +cm.10) • **DE** Sandwiches Platte über Elektrische Griddle - platte cm. 29x40 (VORSICHT: TIEFE MACHINE +cm.10) • **FR** Plaque pour sandwichs au-dessus électrique fry-top - plaque cm. 29x40 (ATTENTION: PROFONDEUR MACHINE +cm.10) • **ES** Plancia para sándwiches sobre fry-top eléctrico - plancia cm. 29x40 (ATENCIÓN: PROFUNDIDAD MÁQUINA +cm.10)  
**cm. 32x 61x 41h**



$\frac{2,9 KW}{230V\sim}$  **933,00**  
 $\frac{50/60 Hz}{20 / 0,21}$

**PCT-63ET PIANO COTTURA TRIFASE N. 2 PIASTRE**  
16030330  
**EN** Boiling unit - N. 2 plates • **DE** Kochplatte - N. 2 Kochplatten • **FR** Rechaud - N. 2 plaques • **ES** Sobre de cocción - N. 2 planchas  
**cm. 30x 60x 28h**



$\frac{3 kW}{400V\sim 2N}$  **628,00**  
 $\frac{230V\sim 3}{16 / 0,14}$   
 $\frac{230V\sim}{50/60 Hz}$

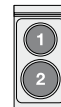

**PCT-66ET PIANO COTTURA TRIFASE N. 4 PIASTRE**  
16030630  
**EN** Boiling unit - N. 4 plates • **DE** Kochplatte - N. 4 Kochplatten • **FR** Rechaud - N. 4 plaques • **ES** Sobre de cocción - N. 4 planchas  
**cm. 60x 60x 28h**



$\frac{6 kW}{400V\sim 3N}$  **1.010,00**  
 $\frac{230V\sim 3}{27 / 0,27}$   
 $\frac{230V\sim}{50/60 Hz}$

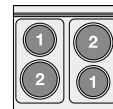

**PCTT-63ET PIANO COTTURA VETROCERAMICA TRIFASE - N. 2 ZONE - VETRO CM.25X47**  
16030332  
**EN** Ceramic glass boiling unit - n. 2 zones - glass cm.25x47 • **DE** Ceran-Kochplatte dreiphasig - 2 zonen - Glas 25x47 cm • **FR** Plan de cuisson à vitroceramique triphasé N. 2 zones - Verre cm.25x47 • **ES** Sobre de cocción trifásico vitrocerámica - 2 zonas - vidrio cm.35x57  
**cm. 30x 60x 28h**



$\frac{3 kW}{400V\sim 2N}$  **1.388,00**  
 $\frac{230V\sim 3}{19 / 0,14}$   
 $\frac{230V\sim}{50/60 Hz}$



Le immagini presentate non sono vincolanti. La ditta si riserva di apportare modifiche senza preavviso. • The pictures are purely representative. The manufacturer reserves the right to modify the technical data and models without previous notice. • Les images

LO

présentées ne nous engagent pas. La Société se réserve le droit d'apporter tout modification sans préavis. • Die dargestellten Abbildungen sind nicht verbindlich. Technische Änderungen vorbehalten. • Las imágenes presentadas no son vinculantes. El Fabricante se reserva el derecho de modificar sus productos sin previo aviso.

01/20

51

60

# PIANI COTTURA ELETTRICI - TOP

MOD. \_\_\_\_\_  
COD. \_\_\_\_\_

DESCRIZIONE/DESCRIPTION/BEZEICHNUNG/DESCRIPTION/DESCRIPCIÓN  
DIMENSIONI/DIMENSIONS/ABMESSUNGEN/DIMENSIONS/DIMENSIONES

POTENZA/POWER/LEISTUNG/PUISSANCE/POTENCIA  
VOLTAGGIO/VOLTAGE/SPANNUNG/VOLTAGE/VOLTAJE

⚡ kW \_\_\_\_\_ kcal/h \_\_\_\_\_  
V~ \_\_\_\_\_ Hz \_\_\_\_\_

PREZZO/PRICE € \_\_\_\_\_  
PREIS/PRIX/PRECIO € \_\_\_\_\_  
KG / M<sup>3</sup> \_\_\_\_\_

**PCCT-66ET**  
16030632

**PIANO COTTURA VETROCERAMICA TRIFASE - N. 4 ZONE - VETRO CM.55X47**  
**EN** Ceramic glass boiling unit - n. 4 zones - glass cm.55x47 • **DE** Ceran-Kochplatte dreiphasig - 4 zonen - Glas 55x47 cm • **FR** Plan de cuisson à vitroceramique triphasé N. 4 zones - Verre cm.55x47 • **ES** Sobre de cocción trifásico vitrocerámica - 2 zonas - vidrio cm.35x57  
**cm. 60x 60x 28h**



⚡ 6 kW \_\_\_\_\_ **2.368,00**  
400V~3N \_\_\_\_\_ 26 / 0,27  
230V~3 \_\_\_\_\_  
230V~ \_\_\_\_\_  
50/60 Hz \_\_\_\_\_

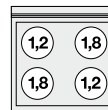

**PCIT-64ET**  
16030433

**PIANI COTTURA A INDUZIONE TRIFASE - VETRO CM 35X47 (NON POSIZIONARE SU FORNI O CASSETTIERE)**  
**EN** Three-phase induction cooking top - Plates cm 35x47 (do not place on ovens or drawers) • **DE** Induktions-Kochplatte dreiphasig cm 35x47 (nicht Platz auf Öfen oder Schubladen) • **FR** Plan de cuisson à induction triphasé - Verre cm. 35x47 (ne placez pas sur des fours ou des tiroirs) • **ES** Encimera inducción trifásica - Vidrio cm. 35x47 (No coloque en los hornos o en los cajones)  
**cm. 40x 60x 28h**



⚡ 5 kW \_\_\_\_\_ **4.240,00**  
400V~3 \_\_\_\_\_ 23 / 0,18  
50/60 Hz \_\_\_\_\_

**PCIT-64ETD**  
16030438

**PIANI COTTURA A INDUZIONE TRIFASE - VETRO CM 35X47 (NON POSIZIONARE SU FORNI O CASSETTIERE) - COMANDI DIGITALI**  
**EN** Three-phase induction cooking top - Plates cm 35x47 (do not place on ovens or drawers) - digital controls • **DE** Induktions-Kochplatte dreiphasig cm 35x47 (nicht Platz auf Öfen oder Schubladen) - digitale Steuerungen • **FR** Plan de cuisson à induction triphasé - Verre cm. 35x47 (ne placez pas sur des fours ou des tiroirs) - commandes numériques • **ES** Encimera inducción trifásica - Vidrio cm. 35x47 (No coloque en los hornos o en los cajones) - controles digitales  
**cm. 40x 60x 28h**



⚡ 5 kW \_\_\_\_\_ **4.481,00**  
400V~3 \_\_\_\_\_ 23 / 0,18  
50/60 Hz \_\_\_\_\_

**PCIWT-64ET**  
16030434

**PIANI COTTURA A INDUZIONE WOK 1 PIASTRA INDUZIONE - VETRO Ø 30 CM (NON POSIZIONARE SU FORNI O CASSETTIERE)**  
**EN** Three-phase wok induction cooking top 1 glass induction plates Ø 30 cm (do not place on ovens or drawers) • **DE** Induktions-Kochplatte dreiphasig Wok 1 Glasinduktionsplatten Ø 30 cm (nicht Platz auf Öfen oder Schubladen) • **FR** Plan de cuisson à induction triphasé wok 1 plaques à induction - Verre Ø 30 cm (ne placez pas sur des fours ou des tiroirs) • **ES** Encimera inducción trifásica wok 1 placas inducción - Vidrio Ø 30 cm (No coloque en los hornos o en los cajones)  
**cm. 40x 60x 28h**



⚡ 5 kW \_\_\_\_\_ **4.394,00**  
400V~3 \_\_\_\_\_ 23 / 0,18  
50/60 Hz \_\_\_\_\_

**PCIWT-64ETD**  
16030439

**PIANI COTTURA A INDUZIONE WOK 1 PIASTRA INDUZIONE - VETRO Ø 30 CM (NON POSIZIONARE SU FORNI O CASSETTIERE) - COMANDI DIGITALI**  
**EN** Three-phase wok induction cooking top 1 glass induction plates Ø 30 cm (do not place on ovens or drawers) - digital controls • **DE** Induktions-Kochplatte dreiphasig Wok 1 Glasinduktionsplatten Ø 30 cm (nicht Platz auf Ofen oder Schubladen) - digitale Steuerungen • **FR** Plan de cuisson à induction triphasé wok 1 plaques à induction - Verre Ø 30 cm (ne placez pas sur des fours ou des tiroirs) - commandes numériques • **ES** Encimera inducción trifásica wok 1 placas inducción - Vidrio Ø 30 cm (No coloque en los hornos o en los cajones) - controles digitales  
**cm. 40x 60x 28h**

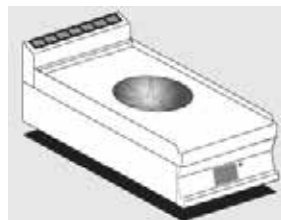

⚡ 5 kW \_\_\_\_\_ **4.635,00**  
400V~3 \_\_\_\_\_ 23 / 0,18  
50/60 Hz \_\_\_\_\_



# PIANI COTTURA A GAS - TOP

MOD. \_\_\_\_\_  
COD. \_\_\_\_\_

DESCRIZIONE/DESCRIPTION/BEZEICHNUNG/DESCRIPTION/DESCRIPCIÓN  
DIMENSIONI/DIMENSIONS/ABMESSUNGEN/DIMENSIONS/DIMENSIONES

POTENZA/POWER/LEISTUNG/PUISSANCE/POTENCIA  
VOLTAGGIO/VOLTAGE/SPANNUNG/VOLTAGE/VOLTAJE

⚡ kW kcal/h  
⚡ kw kcal/h  
V~ Hz

PREZZO/PRICE €  
PREIS/PRIX/PRECIO €  
KG / M<sup>3</sup>

**PCT-63G**  
16210350

**PIANO COTTURA A GAS, 2 FUOCHI**  
**EN** Gas heated boiling - 2 burners • **DE** Gas-Kochplatte - 2 Kochstellen • **FR** Rechaud gaz - 2 feux vifs • **ES** Sobres de cocción gas - 2 quemadores  
**cm. 30x 60x 28h**



⚡ 9 kW  
7.740 kcal/h

**948,00**  
20 / 0,14

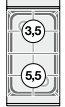

**PCT-66G**  
16210650

**PIANO COTTURA A GAS, 4 FUOCHI**  
**EN** Gas heated boiling - 4 burners • **DE** Gas-Kochplatte - 4 Kochstellen • **FR** Rechaud gaz - 4 feux vifs • **ES** Sobres de cocción gas - 4 quemadores  
**cm. 60x 60x 28h**



⚡ 18 kW  
15.480 kcal/h

**1.491,00**  
31 / 0,27

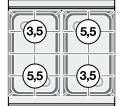

**PCT-610G**  
16211050

**PIANO COTTURA A GAS, 6 FUOCHI**  
**EN** Gas heated boiling - 6 burners • **DE** Gas-Kochplatte - 6 Kochstellen • **FR** Rechaud gaz - 6 feux vifs • **ES** Sobres de cocción gas - 6 quemadores  
**cm. 100x 60x 28h**



⚡ 27 kW  
23.220 kcal/h

**2.400,00**  
63 / 0,43

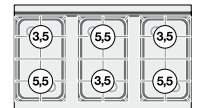

**PCT-64G**  
16210451

**PIANO COTTURA A GAS, 1 FUOCO**  
**EN** Gas heated boiling - 1 burner • **DE** Gas-Kochplatte - 1 Kochstellen • **FR** Rechaud gaz - 1 feux vifs • **ES** Sobres de cocción gas - 1 quemador  
**cm. 40x 60x 28h**



⚡ 10 kW  
8.600 kcal/h

**918,00**  
23 / 0,18



**PCT-68G**  
16210851

**PIANO COTTURA A GAS, 2 FUOCHI**  
**EN** Gas heated boiling - 2 burners • **DE** Gas-Kochplatte - 2 Kochstellen • **FR** Rechaud gaz - 2 feux vifs • **ES** Sobres de cocción gas - 2 quemadores  
**cm. 80x 60x 28h**



⚡ 17 kW  
14.620 kcal/h

**1.449,00**  
39 / 0,35

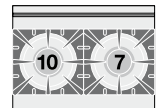

**PC3T-612G**  
16211251

**PIANO COTTURA A GAS, 3 FUOCHI**  
**EN** Gas heated boiling - 3 burners • **DE** Gas-Kochplatte - 3 Kochstellen • **FR** Rechaud gaz - 3 feux vifs • **ES** Sobres de cocción gas - 3 quemadores  
**cm. 120x 60x 28h**



⚡ 27 kW  
23.220 kcal/h

**2.119,00**  
54 / 0,52

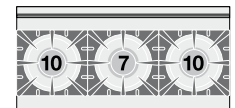

60



Le immagini presentate non sono vincolanti. La ditta si riserva di apportare modifiche senza preavviso. • The pictures are purely representative. The manufacturer reserves the right to modify the technical data and models without previous notice. • Les images

LO

présentées ne nous engagent pas. La Société se réserve le droit d'apporter tout modification sans préavis. • Die dargestellten Abbildungen sind nicht verbindlich. Technische Änderungen vorbehalten. • Las imágenes presentadas no son vinculantes. El Fabricante se reserva el derecho de modificar sus productos sin previo aviso.

01/20

53



# TUTTAPIASTRA A GAS - TOP

MOD. \_\_\_\_\_  
COD. \_\_\_\_\_

DESCRIZIONE/DESCRIPTION/BEZEICHNUNG/DESCRIPTION/DESCRIPCIÓN  
DIMENSIONI/DIMENSIONS/ABMESSUNGEN/DIMENSIONS/DIMENSIONES

POTENZA/POWER/LEISTUNG/PUISSANCE/POTENCIA  
VOLTAGGIO/VOLTAGE/SPANNUNG/VOLTAGE/VOLTAJE

⚡ kW kcal/h  
⚡ kw kcal/h  
V~ Hz

PREZZO/PRICE €  
PREIS/PRIX/PRECIO €  
KG / M<sup>3</sup>

**TPT-64G**  
16290450

**TUTTAPIASTRA A GAS PIASTRA CM 37X50**  
**EN** Solid top - Plate cm 37x50 • **DE** Kochplatte - Platte cm 37x50 • **FR** Toute plaque - Plaque cm 37x50 • **ES** Placa de cocción - Placa cm 37x50  
**cm. 40x 60x 28h**



⚡ 5,5 kW 1.543,00  
4.730 kcal/h 54 / 0,18

**TP4T-610G**  
16301050

**TUTTA PIASTRA + 4 FUOCHI PIASTRA CM. 37X50**  
**EN** Solid top + 4 burners - Plate 37x50cm • **DE** Kochplatte + 4 Gaskochstellen - Platte 37x50 cm • **FR** Toute plaque + 4 brûleurs - Plaque cm. 37x50 • **ES** Placa de cocción + 4 fuegos - Placa cm. 37x50  
**cm. 100x 60x 28h**



⚡ 23,5 kW 3.295,00  
20.210 kcal/h 103 / 0,43

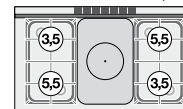

**PLT-62**  
16010200

**PIANO DI LAVORO**  
**EN** Worktop • **DE** Arbeitsplatte • **FR** Plan de travail  
• **ES** Sobre de trabajo  
**cm. 20x 60x 28h**

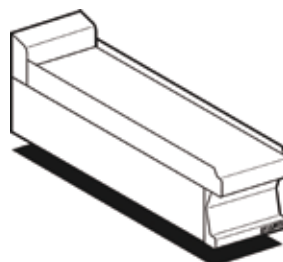

**336,00**  
13 / 0,14

**PLT-63**  
16010300

**PIANO DI LAVORO CON CASSETTO INOX CM.21X47X15H INOX**  
**EN** Worktop with inox drawer cm.21x47x15h inox  
• **DE** Arbeitsplatte mit Schublade inox cm.21x47x15h inox • **FR** Plan de travail avec tiroir inox cm.21x47x15h inox • **ES** Sobre de trabajo con Cajón inox cm.21x47x15h inox  
**cm. 30x 60x 28h**



**430,00**  
21 / 0,14

**PLT-64**  
16010400

**PIANO DI LAVORO CON CASSETTO INOX CM.31X47X15H INOX**  
**EN** Worktop with inox drawer cm.31x47x15h inox  
• **DE** Arbeitsplatte mit Schublade inox cm.31x47x15h inox • **FR** Plan de travail avec tiroir inox cm.31x47x15h inox • **ES** Sobre de trabajo con Cajón inox cm.31x47x15h inox  
**cm. 40x 60x 28h**



**453,00**  
22 / 0,18

**PLT-66**  
16010600

**PIANO DI LAVORO CON CASSETTO INOX CM.51X47X15H INOX**  
**EN** Worktop with inox drawer cm.51x47x15h inox  
• **DE** Arbeitsplatte mit Schublade inox cm.51x47x15h inox • **FR** Plan de travail avec tiroir inox cm.51x47x15h inox • **ES** Sobre de trabajo con Cajón inox cm.51x47x15h inox  
**cm. 60x 60x 28h**



**646,00**  
25 / 0,27

# PIANI LAVORO - TOP

MOD. \_\_\_\_\_  
COD. \_\_\_\_\_

DESCRIZIONE/DESCRIPTION/BEZEICHNUNG/DESCRIPTION/DESCRIPCIÓN  
DIMENSIONI/DIMENSIONS/ABMESSUNGEN/DIMENSIONS/DIMENSIONES

POTENZA/POWER/LEISTUNG/PUISSANCE/POTENCIA  
VOLTAGGIO/VOLTAGE/SPANNUNG/VOLTAGE/VOLTAJE

⚡ kW kcal/h  
⚡ kw V~ Hz

PREZZO/PRICE €  
PREIS/PRIX/PRECIO €  
KG / M<sup>3</sup>

**PLT-68**  
16010800

**PIANO DI LAVORO CON CASSETTO INOX  
CM.71X47X15H INOX**

**EN** Worktop with inox drawer cm.71x47x15h inox  
• **DE** Arbeitsplatte mit Schublade inox cm.71x47x15h  
inox • **FR** Plan de travail avec tiroir inox  
cm.71x47x15h inox • **ES** Sobre de trabajo con Cajón  
inox cm.71x47x15h inox  
**cm. 80x 60x 28h**



**791,00**  
38 / 0,35

**PLT-610**  
16011000

**PIANO DI LAVORO CON 2 CASSETTI INOX,  
1XCM.51X47X15H + 1XCM.31X47X15H**

**EN** Worktop with 2 inox drawers, 1xcm.51x47x15h +  
1xcm.31x47x15h • **DE** Arbeitsplatte mit 2 Schublade  
inox, 1xcm.51x47x15h + 1xcm.31x47x15h • **FR**  
Plan de travail avec 2 tiroirs inox, 1xcm.51x47x15h +  
1xcm.31x47x15h • **ES** Sobre de trabajo con 2 Cajónes  
inox, 1xcm.51x47x15h + 1xcm.31x47x15h  
**cm. 100x 60x 28h**



**1.099,00**  
51 / 0,43

**PLA-68**  
06010801

**PIANO DI LAVORO AD ANGOLO SU MOBILE**

**EN** Corner base with door • **DE** Eckschrank mit Tür  
• **FR** Placard d'angle avec porte • **ES** Base angular con  
puerta  
**cm.80÷80x 60x 90h**



**1.311,00**  
50 / 0,89

**LAT-64**  
16020400

**LAVELLO 1 VASCA RUBINETTO A LEVA - VASCA  
CM 29X35X14H**

**EN** Sink unit - Lever type tap - Bowl cm 29x35x14h  
• **DE** Spülbecken - Einhebel-Mischbatterie Becken cm  
29x35x14h • **FR** Bac-evier avec robinetterie - Bac cm  
29x35x14h • **ES** Fregadero - Grifo a palanca - Pileta  
cm 29x35x14h  
**cm. 40x 60x 28h**



**771,00**  
20 / 0,18

**LAT-68**  
16020800

**LAVELLO 2 VASCHE CM 29X35X14H  
RUBINETTO A LEVA**

**EN** Sink unit - Lever type tap - 2 Bowls cm 29x35x14h  
• **DE** Spülbecken - Einhebel-Mischbatterie 2 Becken cm  
29x35x14h • **FR** Bac-evier avec robinetterie - 2 Bac cm  
29x35x14h • **ES** Fregadero - Grifo a palanca - 2 Pileta  
cm 29x35x14h  
**cm. 80x 60x 28h**



**1.173,00**  
32 / 0,35

**LAT-610DX**  
16021000

**LAVELLO PREDISPOSTO - VASCA CM  
29X35X14H DX SGOCCIOLATOIO CM 60 SX -  
RUBINETTO A LEVA A NORME.**

**EN** Sink unit - R/h Bowl cm 29x35x14h - L/h Draining  
board cm 60 Suitable for dishwasher - Lever type  
tap. • **DE** Spülbecken - Becken cm 29x35x14h  
rechts Abtropffläche cm 60 links - Vorbereitung für  
Geschirrspülmaschine - Einhebel-Mischbatterie • **FR**  
Plan evier - Bac à droite cm 29x35x14h Égouttoir  
à gauche cm 60 Prêdisposé pour lave-vaisselle  
Robinetterie • **ES** Fregadero predispuesto - Pileta cm  
29x35x14h derecho Escurridor 60 cm izq. - Grifo a  
palanca según normativa  
**cm. 100x 60x 28h**



**1.062,00**  
36 / 0,43

60



Le immagini presentate non sono vincolanti. La ditta si riserva di apportare modifiche senza preavviso. • The pictures are purely representative. The manufacturer reserves the right to modify the technical data and models without previous notice. • Les images

LO

présentées ne nous engagent pas. La Société se réserve le droit d'apporter tout modification sans préavis. • Die dargestellten Abbildungen sind nicht verbindlich. Technische Änderungen vorbehalten. • Las imágenes presentadas no son vinculantes. El Fabricante se reserva el derecho de modificar sus productos sin previo aviso.

01/20

55

MOD. \_\_\_\_\_  
COD. \_\_\_\_\_

DESCRIZIONE/DESCRIPTION/BEZEICHNUNG/DESCRIPTION/DESCRIPCIÓN  
DIMENSIONI/DIMENSIONS/ABMESSUNGEN/DIMENSIONS/DIMENSIONES

POTENZA/POWER/LEISTUNG/PUISSANCE/POTENCIA  
VOLTAGGIO/VOLTAGE/SPANNUNG/VOLTAGE/VOLTAJE

⚡ kcal/h    ⚡ kw  
V~    Hz

PREZZO/PRICE €  
PREIS/PRIX/PRECIO €  
KG / M<sup>3</sup>

**LAT-6105X**  
16021001

**LAVELLO PREDISPOSTO - VASCA CM 29X35X14H SX SGOCCIOLATOIO CM 60 DX - RUBINETTO A LEVA A NORME.**

**EN** Sink unit - L/h Bowl cm 29x35x14h - R/h Draining board cm 60 Suitable for dishwasher - Lever type tap. • **DE** Spülbecken - Becken cm 29x35x14h links Abtropffläche cm 60 rechts - Vorbereitung für Geschirrspülmaschine - Einhebel-Mischbatterie • **FR** Plan evier - Bac à gauche cm 29x35x14h Égouttoir à droite cm 60 Prêdisposé pour lave-vaisselle Robinetterie • **ES** Fregadero predispuesto - Pileta cm 29x35x14h izq. Escurridor 60 cm derecho - Grifo a palanca según normativa

**cm. 100x 60x 28h**



**1.062,00**  
36 / 0,43

**LAA-68**  
06020801

**LAVELLO AD ANGOLO SU MOBILE VASCA CM 50X40X20H**

**EN** Corner base with sink and door Bowl cm 50x40x20h • **DE** Eckschrank mit Spülbecken und mit Tür Becken cm 50x40x20h • **FR** Placard d'angle avec porte et evier Cuve cm 50x40x20h • **ES** Con fregadero y puerta cm. Cuba cm 50x40x20h

**cm.80÷80x 60x 90h**



**1.584,00**  
50 / 0,89

**MFM-68EM**  
06490812

**BASE CON FORNO ELETTRICO MULTIFUNZIONE CM. 46X37X35H, TEMP: 50÷250°C, CON 1 GRIGLIA CM.41X32,5 - PORTA VETRO (NON SOVRAPPORRE ELEMENTI AD INDUZIONE)**

**EN** Stand with Multifunction electric oven cm. 46x37x35h, temp: 50÷250°C, with 1 grid cm.41x32,5 - Glass door (no induction top) • **DE** unterbau mit Multifunktions-Elektroofen cm. 46x37x35h, temp: 50÷250°C, mit 1 Rost cm.41x32,5 - Glastür (nicht Induktions) • **FR** placard avec Four électrique à fonctions multiples cm. 46x37x35h, temp: 50÷250°C, avec 1 grille cm.41x32,5 - Porte vitrée (il faut pas de induction) • **ES** mueble con Horno eléctrico multifuncional cm. 46x37x35h, temp: 50÷250°C, con 1 parilla cm.41x32,5 - Puerta vidrio (no inducción)

**cm. 80x 57,5x 57h**



⚡ 3,05 kW    **2.286,00**  
230V~    51 / 0,43  
50/60 Hz

**MFM-68EM**  
06490813

**BASE CON FORNO ELETTRICO MULTIFUNZIONE CM. 46X37X35H, TEMP: 50÷250°C, CON 1 GRIGLIA CM.41X32,5 - PORTA CIECA INOX (NON SOVRAPPORRE ELEMENTI AD INDUZIONE)**

**EN** Stand with Multifunction electric oven cm. 46x37x35h, temp: 50÷250°C, with 1 grid cm.41x32,5 - Stainless steel door (no induction top) • **DE** unterbau mit Multifunktions-Elektroofen cm. 46x37x35h, temp: 50÷250°C, mit 1 Rost cm.41x32,5 - Edelstahltür (nicht Induktions) • **FR** placard avec Four électrique à fonctions multiples cm. 46x37x35h, temp: 50÷250°C, avec 1 grille cm.41x32,5 - Porte acier inoxydable (il faut pas de induction) • **ES** mueble con Horno eléctrico multifuncional cm. 46x37x35h, temp: 50÷250°C, con 1 parilla cm.41x32,5 - Puerta ciega inox (no inducción)

**cm. 80x 57,5x 57h**



⚡ 3,05 Kw    **2.286,00**  
230V~    51 / 0,43  
50/60 Hz

# BASE CON FORNO ELETTRICO

MOD. \_\_\_\_\_  
COD. \_\_\_\_\_

DESCRIZIONE/DESCRIPTION/BEZEICHNUNG/DESCRIPTION/DESCRIPCIÓN  
DIMENSIONI/DIMENSIONS/ABMESSUNGEN/DIMENSIONS/DIMENSIONES

POTENZA/POWER/LEISTUNG/PUISSANCE/POTENCIA  
VOLTAGGIO/VOLTAGE/SPANNUNG/VOLTAGE/VOLTAJE

⚡ kW kcal/h  
230V~  
50/60 Hz

PREZZO/PRICE €  
PREIS/PRIX/PRECIO €  
KG / M<sup>3</sup>

**MFM-610EM BASE CON FORNO ELETTRICO**  
06491012 **MULTIFUNZIONE CM. 64X37X35H, TEMP: 50÷250°C, CON 1 GRIGLIA CM.53X32,5 GN1/1 - PORTA VETRO (NON SOVRAPPORRE ELEMENTI AD INDUZIONE)**  
**EN** Stand with Multifunction electric oven cm. 64x37x35h, temp: 50÷250°C, with 1 grid cm.53x32,5 GN1/1 - Glass door (no induction top) • **DE** unterbau mit Multifunktions-Elektroofen cm. 64x37x35h, temp: 50÷250°C, mit 1 Rost cm.53x32,5 GN1/1 - Glastür (nicht Induktions) • **FR** placard avec Four électrique à fonctions multiples cm. 64x37x35h, temp: 50÷250°C, avec 1 grille cm.53x32,5 GN1/1 - Porte vitrée (il faut pas de induction) • **ES** mueble con Horno eléctrico multifuncional cm. 64x37x35h, temp: 50÷250°C, con 1 parilla cm.53x32,5 GN1/1 - Puerta vidrio (no inducción)  
**cm. 100x 57,5x 57h**



⚡ 3,05 kW **2.524,00**  
230V~ 59 / 0,53  
50/60 Hz

**MFM-610EM BASE CON FORNO ELETTRICO**  
06491013 **MULTIFUNZIONE CM. 64X37X35H, TEMP: 50÷250°C, CON 1 GRIGLIA CM.53X32,5 GN1/1 - PORTA CIECA INOX (NON SOVRAPPORRE ELEMENTI AD INDUZIONE)**  
**EN** Stand with Multifunction electric oven cm. 64x37x35h, temp: 50÷250°C, with 1 grid cm.53x32,5 GN1/1 - Stainless steel door (no induction top) • **DE** unterbau mit Multifunktions-Elektroofen cm. 64x37x35h, temp: 50÷250°C, mit 1 Rost cm.53x32,5 GN1/1 - Edelstahltür (nicht Induktions) • **FR** placard avec Four électrique à fonctions multiples cm. 64x37x35h, temp: 50÷250°C, avec 1 grille cm.53x32,5 GN1/1 - Porte acier inoxydable (il faut pas de induction) • **ES** mueble con Horno eléctrico multifuncional cm. 64x37x35h, temp: 50÷250°C, con 1 parilla cm.53x32,5 GN1/1 - Puerta ciega inox (no inducción)  
**cm. 100x 57,5x 57h**



⚡ 3,05 kW **2.524,00**  
230V~ 59 / 0,53  
50/60 Hz

**CMF-68 COPERCHIO PER MFM-68E**  
06490800 **EN** Lid for MFM-68E • **DE** Berichterstattung für MFM-68E • **FR** Couverture pour MFM-68E • **ES** cubertura para MFM-68E  
**cm. 80x 54x 2,8h**



**166,00**  
4 / 0,02

**CMF-610 COPERCHIO PER MFM-610E**  
06491000 **EN** Lid for MFM-610E • **DE** Berichterstattung für MFM-610E • **FR** Couverture pour MFM-610E • **ES** cubertura para MFM-610E  
**cm. 100x 54x 2,8h**

**212,00**  
5 / 0,03

**MPI-64 BASE CON PORTA PER INDUZIONE**  
06410403 **EN** Stand with door for induction top • **DE** Unterbau für Induktions mit Tür • **FR** Placard pour induction avec porte • **ES** Mueble base para inducción con puerta  
**cm. 40x 51x 57h**



**526,00**  
18,5 / 0,14

**M-62 BASE NEUTRA**  
06410200 **EN** Stand • **DE** Unterbau • **FR** Placard • **ES** Mueble base  
**cm. 20x 48,5x 57h**



**301,00**  
11 / 0,09



Le immagini presentate non sono vincolanti. La ditta si riserva di apportare modifiche senza preavviso. • The pictures are purely representative. The manufacturer reserves the right to modify the technical data and models without previous notice. • Les images

**LO**

présentées ne nous engagent pas. La Société se réserve le droit d'apporter tout modification sans préavis. • Die dargestellten Abbildungen sind nicht verbindlich. Technische Änderungen vorbehalten. • Las imágenes presentadas no son vinculantes. El Fabricante se reserva el derecho de modificar sus productos sin previo aviso.

01/20

**57**

60

MOD. \_\_\_\_\_  
COD. \_\_\_\_\_

DESCRIZIONE/DESCRIPTION/BEZEICHNUNG/DESCRIPTION/DESCRIPCIÓN  
DIMENSIONI/DIMENSIONS/ABMESSUNGEN/DIMENSIONS/DIMENSIONES

POTENZA/POWER/LEISTUNG/PUISSANCE/POTENCIA  
VOLTAGGIO/VOLTAGE/SPANNUNG/VOLTAGE/VOLTAJE

⚡ kW  
kcal/h

⚡ kw  
V~  
Hz

PREZZO/PRICE €  
PREIS/PRIX/PRECIO €  
KG / M<sup>3</sup>

<b>M-63</b> 06410300	<b>BASE NEUTRA A GIORNO</b> EN Open Stand • DE Offener Unterbau • FR Placard ouvert • ES Mueble base abierto cm. 30x 48,5x 57h		<b>292,00</b> 13 / 0,11
<b>M-64</b> 06410400	cm. 40x 48,5x 57h		<b>328,00</b> 15 / 0,14
<b>M-66</b> 06410600	cm. 60x 48,5x 57h		<b>363,00</b> 19 / 0,20
<b>M-67</b> 06410700	cm. 70x 48,5x 57h		<b>398,00</b> 20 / 0,23
<b>M-68</b> 06410800	cm. 80x 48,5x 57h		<b>426,00</b> 22 / 0,26
<b>M-69</b> 06410900	cm. 90x 48,5x 57h		<b>530,00</b> 25 / 0,29
<b>M-610</b> 06411000	cm. 100x 48,5x 57h		<b>554,00</b> 27 / 0,32
<b>M-612</b> 06411200	cm. 120x 48,5x 57h		<b>591,00</b> 32 / 0,37
<b>S-63</b> 06400300	<b>CAVALLETTO BASE</b> EN Stand • DE Untergestell • FR Piedement simple • ES Soporte base cm. 30x 48,5x 57h		<b>340,00</b> 18 / 0,11
<b>S-64</b> 06400400	cm. 40x 48,5x 57h		<b>357,00</b> 19 / 0,14
<b>S-66</b> 06400600	cm. 60x 48,5x 57h		<b>369,00</b> 23 / 0,20
<b>S-68</b> 06400800	cm. 80x 48,5x 57h		<b>456,00</b> 26 / 0,26
<b>S-610</b> 06401000	cm. 100x 48,5x 57h		<b>497,00</b> 29 / 0,32
<b>PM-63/73/93-DX</b> 08430302	<b>PORTA 300 DESTRA</b> EN Right door 300 • DE Rechte tür 300 • FR Porte droite 300 • ES Puerta derecha 300 cm. 29,5x 2,5x 47,5h		<b>157,00</b> 3 / 0,01



# ACCESSORI

MOD. \_\_\_\_\_  
COD. \_\_\_\_\_

DESCRIZIONE/DESCRIPTION/BEZEICHNUNG/DESCRIPTION/DESCRIPCIÓN  
DIMENSIONI/DIMENSIONS/ABMESSUNGEN/DIMENSIONS/DIMENSIONES

POTENZA/POWER/LEISTUNG/PUISSANCE/POTENCIA  
VOLTAGGIO/VOLTAGE/SPANNUNG/VOLTAGE/VOLTAJE

⚡ kW kcal/h  
⚡ kW V~ Hz

PREZZO/PRICE €  
PREIS/PRIX/PRECIO €  
KG / M<sup>3</sup>

**PM-64/74/94-DX PORTA 400 DESTRA**  
08430402 **EN** Right door 400 • **DE** Rechte tür 400 • **FR** Porte droite 400 • **ES** Puerta derecha 400  
**cm. 39,5x 2,5x 47,5h**



**163,00**  
3.5 / 0,02

**PM-63/73/93-SX PORTA 300 SINISTRA**  
08430303 **EN** Left door 300 • **DE** Linke tür 300 • **FR** Porte gauche 300 • **ES** Puerta izquierda 300  
**cm. 29,5x 2,5x 47,5h**



**157,00**  
3 / 0,01

**PM-64/74/94-SX PORTA 400 SINISTRA**  
08430403 **EN** Left door 400 • **DE** Linke tür 400 • **FR** Porte gauche 400 • **ES** Puerta izquierda 400  
**cm. 39,5x 2,5x 47,5h**



M-610 =PM-64SX+PM-63SX+PM-63DX

**163,00**  
3.5 / 0,02

**C-63**  
06440320 **CASSETTIERA 300/400/600 - N. 2 CASSETTI CON VASCA INOX GUIDE TELESCOPICHE**  
**EN** Drawer set 300/400/600 - N. 2 drawers with inox pans, telescopic guides • **DE** Schubladen 300/400/600 - N. 2 Schubladen mit chromnickelstahl Telescopeinführungen • **FR** Tiroirs pour meuble de 300/400/600 - N. 2 tiroirs avec cuve inox, Guides télescopiques • **ES** Cajonera 300/400/600 - N. 2 cajones con cuba de acero inox, Guías telescópicas  
**cm. 29,5x 51x 47,5h**



**549,00**  
8 / 0,14

**C-64**  
06440420 **cm. 39,5x 51x 47,5h**

**566,00**  
9 / 0,18

**C-66**  
06440620 **cm. 59,5x 51x 47,5h**



**662,00**  
14 / 0,27

# ACCESSORI

MOD. \_\_\_\_\_  
COD. \_\_\_\_\_

DESCRIZIONE/DESCRIPTION/BEZEICHNUNG/DESCRIPTION/DESCRIPCIÓN  
DIMENSIONI/DIMENSIONS/ABMESSUNGEN/DIMENSIONS/DIMENSIONES

POTENZA/POWER/LEISTUNG/PUISSANCE/POTENCIA  
VOLTAGGIO/VOLTAGE/SPANNUNG/VOLTAGE/VOLTAJE

⚡ kW kcal/h  
⚡ kw V~ Hz

PREZZO/PRICE €  
PREIS/PRIX/PRECIO €  
KG / M<sup>3</sup>

**R-63**  
06450300  
**RIPIANO 300**  
**EN** Shelf 300 • **DE** Zwischenboden 300 • **FR** Etagère 300 • **ES** Estante 300  
**cm. 25x 48x 2h**

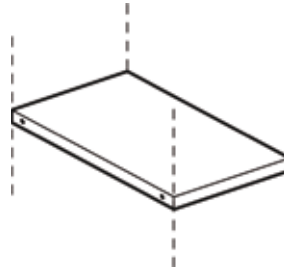

**67,00**  
1,5 / 0,01

**R-64**  
06450400  
**RIPIANO 400**  
**EN** Shelf 400 • **DE** Abstellbrett 400 • **FR** Etagère 400 • **ES** Estante 400  
**cm. 35x 48x 2h**

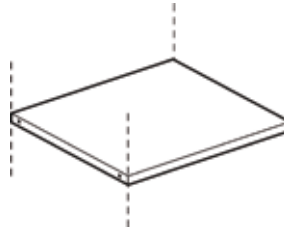

**74,00**  
2,5 / 0,01

**R-66**  
06450600  
**RIPIANO 600**  
**EN** Shelf 600 • **DE** Abstellbrett 600 • **FR** Etagère 600 • **ES** Estante 600  
**cm. 55x 48x 2h**



**84,00**  
3 / 0,01

**544023800** **RASCHIETTO PER PIASTRA RIGATA**  
**EN** Scraper for gooved plate • **DE** Schaber für gerillte Kochplatte • **FR** Racloir pour plaque nervurée • **ES** Rasqueta para placa ranurada



**50,00**  
/ 1,00

**531040800** **RASCHIETTO PER PIASTRA LISCIA CROMATA**  
**EN** Scraper for smooth chromed plate • **DE** Schaber für glatte verchromte Platte • **FR** Racloir pour plaque lisse au chrome • **ES** Rasqueta para placa lisa cromada



**47,00**  
/ 1,00

**531040900** **KIT 10 LAME PER RASCHIETTO**  
**EN** 10 blades kit for scraper • **DE** Kit 10 Klingen für Schaber • **FR** Kit de 10 lames pour racloir • **ES** Kit de 10 cuchillas para rasqueta

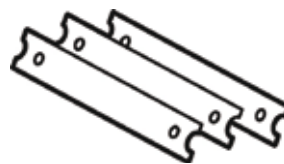

**33,00**  
/ 0,00

**T-FT**  
09580060  
**TAPPO PER FRY-TOP**  
**EN** stopper for Fry-top • **DE** Stopfen griddleplatte • **FR** bouchon pour Plaque • **ES** tapón Fry-top  
**cm. 10x 2x 5h**

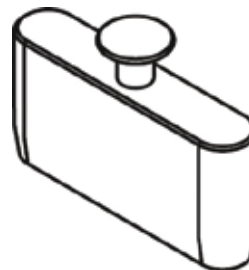

**198,00**  
/ 0,00

# ACCESSORI FRY-TOP





MOD. \_\_\_\_\_  
COD. \_\_\_\_\_

DESCRIZIONE/DESCRIPTION/BEZEICHNUNG/DESCRIPCION  
DIMENSIONI/DIMENSIONS/ABMESSUNGEN/DIMENSIONES

POTENZA/POWER/LEISTUNG/PUISSANCE/POTENCIA  
VOLTAGGIO/VOLTAGE/SPANNUNG/VOLTAGE/VOLTAJE

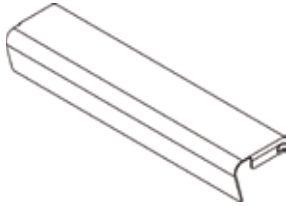
⚡ kW kcal/h  
⚡ kW V~ Hz

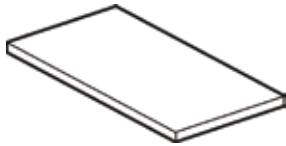
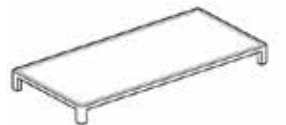
PREZZO/PRICE €  
PREIS/PRIX/PRECIO €  
KG / M<sup>3</sup>

<b>PFT-64</b> 06620400	<b>KIT PROTEZIONE FRONTALE PIANO FRY-TOP</b> <b>EN</b> KIT front protection plan fry-top • <b>DE</b> Schutz-kit vorne Plan griddleplatte • <b>FR</b> KIT protection avant plan plaque • <b>ES</b> KIT de protección frontal plan de fry-top <b>cm. 38x 8x 6h</b>		<b>102,00</b> / 0,00
<b>PFT-66</b> 06620600	<b>cm. 58x 8x 6h</b>		<b>137,00</b> / 0,01
<b>PFT-68</b> 06620800	<b>cm. 78x 8x 6h</b>		<b>172,00</b> / 0,01
<b>PFT-610</b> 06621000	<b>cm. 98x 8x 6h</b>		<b>195,00</b> / 0,01
<b>CG-60</b> 06560000	<b>COPRIGIUNTO</b> <b>EN</b> Joint cover • <b>DE</b> Klemmsteg • <b>FR</b> Couvre-joint • <b>ES</b> Cubre junta <b>cm. 0,7x 52x 1,2h</b>		<b>29,00</b> 0.12 / 1,00
<b>06550400</b>	<b>COPERCHIO BRF-64</b> <b>EN</b> Lid BRF-64 • <b>DE</b> Deckel BRF-64 • <b>FR</b> Couvercle BRF-64 • <b>ES</b> Tapa BRF-64 <b>cm. 33x 45x 5h</b>		<b>110,00</b> / 0,02
<b>06550600</b>	<b>COPERCHIO BRT-66</b> <b>EN</b> Lid BRF-66 • <b>DE</b> Deckel BRF-66 • <b>FR</b> Couvercle BRF-66 • <b>ES</b> Tapa BRF-66 <b>cm. 51x 42x 3h</b>		<b>111,00</b> / 0,02
<b>TG-63</b> 06580300	<b>TAGLIERE PLASTICA</b> <b>EN</b> Plastic chopping-board • <b>DE</b> Schneidebrett • <b>FR</b> Plan de decoupe • <b>ES</b> Picador de plástico <b>cm. 29x 52,5x 2,5h</b>		<b>103,00</b> 4 / 0,01
<b>TG-64</b> 06580400	<b>cm. 39x 52,5x 2,5h</b>		<b>111,00</b> 6 / 0,01
<b>TG-66</b> 06580600	<b>cm. 59x 52,5x 2,5h</b>		<b>187,00</b> 9 / 0,01
<b>TG-68</b> 06580800	<b>cm. 79x 52,5x 2,5h</b>		<b>220,00</b> 11 / 0,02
<b>PLF/62</b> 06590421	<b>PIASTRA LISCIA 2 FUOCHI</b> <b>EN</b> Smooth griddle plate 2 burners • <b>DE</b> Fortkochplatte glatt 2 Kochstellen • <b>FR</b> Plaque lisse 2 feux • <b>ES</b> Plancha lisa 2 quemadores <b>cm. 29x 50</b>		<b>182,00</b> 15 / 0,01
<b>PRF/62</b> 06590423	<b>PIASTRA RIGATA 2 FUOCHI</b> <b>EN</b> Grooved griddle plate 2 burners • <b>DE</b> Fortkochplatte gerillt 2 Kochstellen • <b>FR</b> Plaque nervurée 2 feux • <b>ES</b> Plancha estriada 2 quemadores <b>cm. 29x 50</b>		<b>268,00</b> 15 / 0,01

60



Le immagini presentate non sono vincolanti. La ditta si riserva di apportare modifiche senza preavviso. • The pictures are purely representative. The manufacturer reserves the right to modify the technical data and models without previous notice. • Les images

LO

présentées ne nous engagent pas. La Société se réserve le droit d'apporter tout modification sans préavis. • Die dargestellten Abbildungen sind nicht verbindlich. Technische Änderungen vorbehalten. • Las imágenes presentadas no son vinculantes. El Fabricante se reserva el derecho de modificar sus productos sin previo aviso.

01/20

61

MOD. \_\_\_\_\_  
COD. \_\_\_\_\_

DESCRIZIONE/DESCRIPTION/BEZEICHNUNG/DESCRIPTION/DESCRIPCIÓN  
DIMENSIONI/DIMENSIONS/ABMESSUNGEN/DIMENSIONS/DIMENSIONES

POTENZA/POWER/LEISTUNG/PUISSANCE/POTENCIA  
VOLTAGGIO/VOLTAGE/SPANNUNG/VOLTAGE/VOLTAJE

⚡ kW kcal/h  
⚡ kw V~ Hz

PREZZO/PRICE €  
PREIS/PRIX/PRECIO €  
KG / M<sup>3</sup>

## 533009100 GRIGLIA DI RIDUZIONE

EN Reduction • DE Reduzierstern • FR Grille de réduction • ES Rejilla de reducción  
cm. 15x 15



17,00  
0,2 / 0,00

## 533009200 GRIGLIA DI RIDUZIONE PER PC1/2/3T E CF2/3

EN Reduction PC1/2/3T & CF2/3 • DE Reduzierstern PC1/2/3T & CF2/3 • FR Grille de réduction PC1/2/3T & CF2/3 • ES Rejilla de reducción PC1/2/3T & CF2/3  
cm. 25x 25



31,00  
0.2 / 0,00

## RV

08660410

## RISCALDANTE VANO

EN Heater for cabinet • DE Heizer für Schrankelement • FR Réchauffeur pour armoire • ES elemento de calefacción para armario neutro  
cm. 32x 48,5x 8h

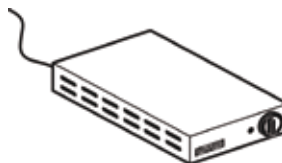

⚡ 0,75 kW  
230V~  
50/60 Hz

721,00  
8 / 0,08

## RRV-64

06450401

## RIPIANO FORATO IN APPOGGIO PER RISCALDANTE (NO CF)

EN Perforated shelf for heater element mod.RV (NO CF) • DE regale Gelocht für Heizer mod.RV (NO CF) • FR Étagère perforées pour réchauffeur mod.RV (NO CF) • ES estante perforado para elemento de calefacción mod.RV (NO CF)  
cm. 34x 46x 10h



249,00  
/

## RRV-66

06450601

cm. 54x 46x 10h

374,00  
/

## RRV-67

06450701

cm. 64x 46x 10h

470,00  
/

## RRV-68

06450801

cm. 74x 46x 10h

480,00  
/

## RRV-69

06450901

cm. 84x 46x 10h

604,00  
/

## RRV-610

06451001

cm. 94x 46x 10h

678,00  
/

## RRV-612

06451201

cm. 114x 46x 10h

808,00  
/

## KIT-WOK

09580040

## KIT WOK - FIAMMA VERTICALE - SOLO SU BRUCIATORE DA 10 KW E GRIGLIE IN GHISA

EN KIT WOK - vertical flame - only for 10 kW burner and cast iron grills • DE KIT WOK - vertikaler Flamme - nur 10 kW-Brenner und Roste aus Gusseisen • FR KIT WOK - verticale de la flamme - seulement 10 kW brûleur et grilles en fonte • ES KIT WOK - llama vertical - sólo 10 kW quemador y parrillas de hierro colado  
cm. Ø 26x 16h



337,00  
5 / 0,02

# ACCESSORI

MOD. \_\_\_\_\_  
COD. \_\_\_\_\_

DESCRIZIONE/DESCRIPTION/BEZEICHNUNG/DESCRIPTION/DESCRIPCIÓN  
DIMENSIONI/DIMENSIONS/ABMESSUNGEN/DIMENSIONS/DIMENSIONES

POTENZA/POWER/LEISTUNG/PUISSANCE/POTENCIA  
VOLTAGGIO/VOLTAGE/SPANNUNG/VOLTAGE/VOLTAJE

⚡ kW kcal/h  
⚡ kW V~ Hz

PREZZO/PRICE €  
PREIS/PRIX/PRECIO €  
KG / M<sup>3</sup>

**544439900 ANELLO PER WOK - SOLO PER GRIGLIE IN GHISA**

EN Wok ring - only for cast iron grills • DE Wok Aufsatzring - nur für Roste aus Gusseisen • FR Anneau Wok - seulement pour grilles en fonte • ES Anillo Wok - solo para parrilas de hierro colado  
**cm. Ø22,5x 3,5h**

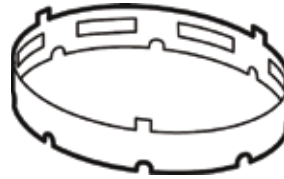

**126,00**  
2 / 0,00

**SIA-7/9 STAFFA INFERIORE UNIONE APPARECCHI**

08480000

EN Lower bracket to join two items

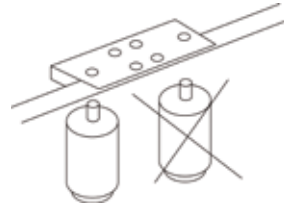

**48,00**  
2 / 0,00

**SR-100 SET 4 RUOTE Ø 100X30, 2 CON FRENO**

50900001

EN Set of 4 wheels Ø 100x30, 2 with brake • DE 4 Rollen Satz Ø 100x30, 2 davon mit Feststellbremse • FR Kit 4 roues Ø 100x30, 2 avec frein • ES Equipo 4 ruedas Ø 100x30, 2 con frenos  
**cm. 12,7h**

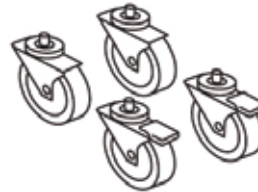

**284,00**  
1 / 0,01

**ZB ZOCCOLATURA BASE**

01410000

EN FRONT PLINTH • DE GRUNDSOCKEL • FR PLINTHE FRONTAL • ES ZOCCOLOS BASE  
**€/m x cm. 15h**

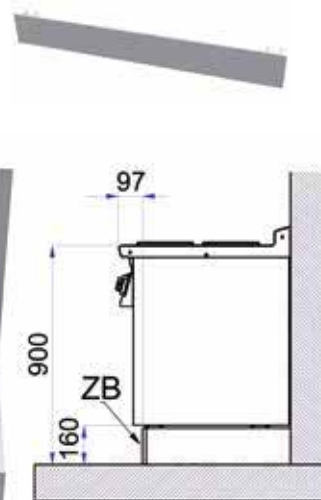

**113,00**  
/

**ZA ZOCCOLATURA ANGOLO**

01410002

EN CORNER PLINTH • DE EKE-SOCKEL • FR PLINTHE ANGLE • ES ZOCCOLOS ANGULAR  
**cm. 15h**

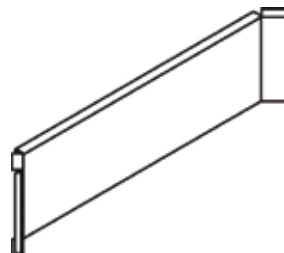

**69,00**  
0.3 / 0,01

**D-60 DIVISORIO - NECESSARIO PER APPLICARE CASSETTIERA C-64 SU MOBILE 70/80**

06470000

EN Spacer - For installation of a C-64 on a stand 70/80 • DE Trennwand - Um ein C-64 an einem Unterschrank 70/80 einzubauen • FR Separation - Pour l'installation de C-64 sur placard 70/80 • ES Divisorio - Necesario para aplicar cajoneras C-64 en Mueble 70/80  
**cm. 5x 48x 38h**

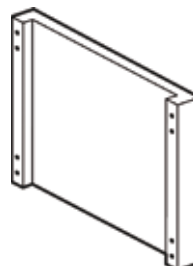

**122,00**  
2 / 0,02



Le immagini presentate non sono vincolanti. La ditta si riserva di apportare modifiche senza preavviso. • The pictures are purely representative. The manufacturer reserves the right to modify the technical data and models without previous notice. • Les images

**LO**

présentées ne nous engagent pas. La Société se réserve le droit d'apporter tout modification sans préavis. • Die dargestellten Abbildungen sind nicht verbindlich. Technische Änderungen vorbehalten. • Las imágenes presentadas no son vinculantes. El Fabricante se reserva el derecho de modificar sus productos sin previo aviso.

01/20

**63**

60



MOD. \_\_\_\_\_  
COD. \_\_\_\_\_

DESCRIZIONE/DESCRIPTION/BEZEICHNUNG/DESCRIPTION/DESCRIPCIÓN  
DIMENSIONI/DIMENSIONS/ABMESSUNGEN/DIMENSIONS/DIMENSIONES

POTENZA/POWER/LEISTUNG/PUISSANCE/POTENCIA  
VOLTAGGIO/VOLTAGE/SPANNUNG/VOLTAGE/VOLTAJE

↓ kW kcal/h  
↑ kw V~ Hz

PREZZO/PRICE €  
PREIS/PRIX/PRECIO €  
KG / M<sup>3</sup>

**PT-64**  
06460002

**PORTATEGLIE VANO - 400 (GN2/3) - VANO 600 (GN1/1)**  
EN Frame for oven plates. 400 GN 2/3 - 600 GN 1/1  
• DE Aufangeschienen für Backbleche. 400 GN 2/3 - 600 GN 1/1  
• FR Kit porte-plaques. 400 GN 2/3 - 600 GN 1/1  
• ES Portacazuelas. 400 GN 2/3 - 600 GN 1/1  
**cm. 2x 47x 30h**

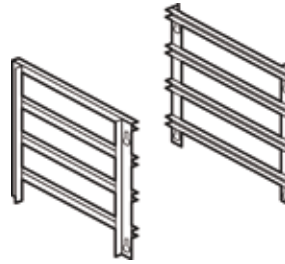

**256,00**  
2.5 / 0,01

**06570401**

**GRIGLIA TONDINO PER CW64 (SERIE 60)**  
EN Grid for CW-64 (60 line) • DE Gitter für CW-64 (60. Serie)  
• FR Grille ronde pour CW-64 (serie 60)  
• ES Rejilla para CW-64 (serie 60)  
**cm. 38x 42**

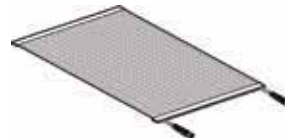

**304,00**  
9 / 0,02

**06570601**

**GRIGLIA TONDINO PER CW66 (SERIE 60)**  
EN Grid for CW-66 (60 line) • DE Gitter für CW-66 (60. Serie)  
• FR Grille ronde pour CW-66 (serie 60)  
• ES Rejilla para CW-66 (serie 60)  
**cm. 58x 42**

**431,00**  
9 / 0,03

**06570402**

**GRIGLIA TEGOLO V PER CW-64 (SERIE 60)**  
EN V TRAY for CW-64 ( 60 LINE)  
• DE V ROSTE FÜR CW-64 (60 LINIE)  
• FR V GRILLE POUR CW-64 ( LIGNE 60)  
• ES V rejilla para CW-64 (serie 60)  
**cm. 36x 43**

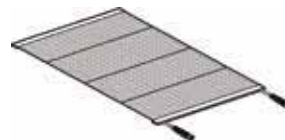

**207,00**  
9 / 0,02

**06570602**

**GRIGLIA TEGOLO V PER CW-66 (SERIE 60)**  
EN V TRAY for CW-66 ( 60 LINE)  
• DE V ROSTE FÜR CW-66 (60 LINIE)  
• FR V GRILLE POUR CW-66 ( LIGNE 60)  
• ES V rejilla para CW-66 (serie 60)  
**cm. 56x 43**

**298,00**  
9 / 0,03

**531017900**

**CESTO 1/3 PER CP-66**  
EN Basket 1/3 for CP-66 • DE Korb 1/3 für CP-66  
• FR Panier 1/3 pour CP-66 • ES Cesta 1/3 para CP-66  
**cm. 16x 29x 20h**

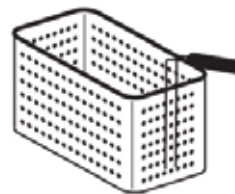

..179..

**107,00**  
1,5 / 0,05

**531064300**

**CESTO 1/4 PER CP-66**  
EN Basket 1/4 for CP-66 • DE Korb 1/4 für CP-66  
• FR Panier 1/4 pour CP-66 • ES Cesta 1/4 para CP-66  
**cm. 11,5x 29x 20h**

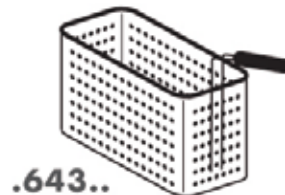

..643..

**95,00**  
1,2 / 0,04

**531053900**

**CESTO 1/1 PER CP-66**  
EN Basket 1/1 for CP-66 • DE Korb 1/1 für CP-66  
• FR Panier 1/1 pour CP-66 • ES Cesta 1/1 para CP-66  
**cm. 49x 29x 20h**

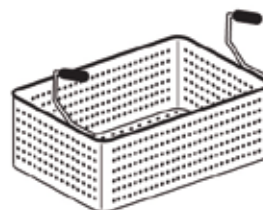

..539..

**147,00**  
3,5 / 0,08

# ACCESSORI CUOCIPASTA

MOD. \_\_\_\_\_  
COD. \_\_\_\_\_

DESCRIZIONE/DESCRIPTION/BEZEICHNUNG/DESCRIPTION/DESCRIPCIÓN  
DIMENSIONI/DIMENSIONS/ABMESSUNGEN/DIMENSIONS/DIMENSIONES

POTENZA/POWER/LEISTUNG/PUISSANCE/POTENCIA  
VOLTAGGIO/VOLTAGE/SPANNUNG/VOLTAGE/VOLTAJE

⚡ kW kcal/h  
⚡ kW V~ Hz

PREZZO/PRICE €  
PREIS/PRIX/PRECIO €  
KG / M<sup>3</sup>

**531018800 CESTO 1/2 PER CPT-64 - 1/3 PER CPT-66**  
EN Basket 1/2 for CPT-64 - 1/3 for CPT-66 • DE Korb 1/2 für CPT-64 - 1/3 für CPT-66 • FR Panier 1/2 pour CPT-64 - 1/3 pour CPT-66 • ES Cesta 1/2 para CPT-64 - 1/3 para CPT-66  
cm. 14,5x 29x 15h

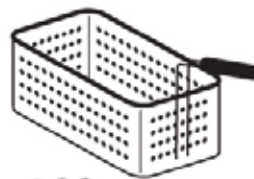

..188..

**103,00**  
1,3 / 0,04

**531053800 CESTO 1/4 PER CPT-66**  
EN Basket 1/4 for CPT-66 • DE Korb 1/4 für CPT-66 • FR Panier 1/4 pour CPT-66 • ES Cesta 1/4 para CPT-66  
cm. 11,5x 29x 15h

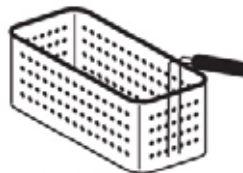

..538..

**97,00**  
1,2 / 0,04

**531040000 CESTO 1/1 PER CPT-66**  
EN Basket 1/1 for CPT-66 • DE Korb 1/1 für CPT-66 • FR Panier 1/1 pour CPT-66 • ES Cesta 1/1 para CPT-66  
cm. 49x 29x 15h



..400..

**176,00**  
3,5 / 0,07

**531053700 CESTO 1/4 PER CPT-64**  
EN Basket 1/4 for CPT-64 • DE Korb 1/4 für CPT-64 • FR Panier 1/4 pour CPT-64 • ES Cesta 1/4 para CPT-64  
cm. 14x 16x 15h

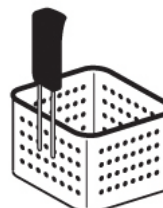

..537..

**69,00**  
1 / 0,02

**531053500 CESTO 1/1 PER CPT-64**  
EN Basket 1/1 for CPT-64 • DE Korb 1/1 für CPT-64 • FR Panier 1/1 pour CPT-64 • ES Cesta 1/1 para CPT-64  
cm. 29x 29x 15h

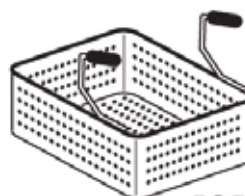

..535..

**127,00**  
1,5 / 0,05

**531071300 CESTO CON GANCIO 1/2 PER CPT-64 - 1/3 PER CPT-66**  
EN Basket with hook 1/2 for CPT-64 - 1/3 for CPT-66 • DE Korb mit Haken 1/2 für CPT-64 - 1/3 für CPT-66 • FR Panier avec crochet 1/2 pour CPT-64 - 1/3 pour CPT-66 • ES Cesta con gancho 1/2 para CPT-64 - 1/3 para CPT-66  
cm. 13,5x 25,5x 15h

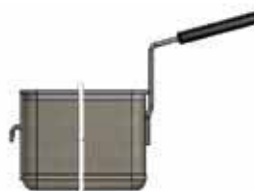

**102,00**  
1,3 / 0,04

**531071400 CESTO CON GANCIO 1/4 PER CPT-66**  
EN Basket with hook 1/4 for CPT-66 • DE Korb mit Haken 1/4 für CPT-66 • FR Panier avec crochet 1/4 pour CPT-66 • ES Cesta con gancho 1/4 para CPT-66  
cm. 11x 25,5x 15h

**95,00**  
1,2 / 0,03



Le immagini presentate non sono vincolanti. La ditta si riserva di apportare modifiche senza preavviso. • The pictures are purely representative. The manufacturer reserves the right to modify the technical data and models without previous notice. • Les images

LO

présentées ne nous engagent pas. La Société se réserve le droit d'apporter tout modification sans préavis. • Die dargestellten Abbildungen sind nicht verbindlich. Technische Änderungen vorbehalten. • Las imágenes presentadas no son vinculantes. El Fabricante se reserva el derecho de modificar sus productos sin previo aviso.

01/20

65

60

# ACCESSORI CUOCIPASTA

MOD. \_\_\_\_\_  
COD. \_\_\_\_\_

DESCRIZIONE/DESCRIPTION/BEZEICHNUNG/DESCRIPTION/DESCRIPCIÓN  
DIMENSIONI/DIMENSIONS/ABMESSUNGEN/DIMENSIONS/DIMENSIONES

POTENZA/POWER/LEISTUNG/PUISSANCE/POTENCIA  
VOLTAGGIO/VOLTAGE/SPANNUNG/VOLTAGE/VOLTAJE

⚡ kW kcal/h  
⚡ kw V~ Hz

PREZZO/PRICE €  
PREIS/PRIX/PRECIO €  
KG / M<sup>3</sup>

**531071200 CESTO CON GANCIO 1/3 PER CP-66**  
EN Basket with hook 1/3 for CP-66 • DE Korb mit Haken 1/3 für CP-66 • FR Panier avec crochet 1/3 pour CP-66 • ES Cesta con gancho 1/3 para CP-66  
cm. 15x 26x 20h



**116,00**  
1,5 / 0,05

**531018700 CESTO CON GANCIO 1/4 PER CP-66**  
EN Basket with hook 1/4 for CP-66 • DE Korb mit Haken 1/4 für CP-66 • FR Panier avec crochet 1/4 pour CP-66 • ES Cesta con gancho 1/4 para CP-66  
cm. 11x 26x 20h

**96,00**  
1,2 / 0,04

**531069400 GRIGLIA SUPPORTO CESTI CON GANCIO PER CP-66**  
EN support for baskets with hook for CP-66 • DE Unterstützung für Körbe mit Haken für CP-66 • FR soutien pour les paniers avec crochet pour CP-66 • ES soporte para cestas con gancho para CP-66  
cm. 50x 29x 41h



**145,00**  
4 / 0,09

**531071800 GRIGLIA SUPPORTO CESTI CON GANCIO PER CPT-64**  
EN support for baskets with hook for CPT-64 • DE Unterstützung für Körbe mit Haken für CPT-64 • FR soutien pour les paniers avec crochet pour CPT-64 • ES soporte para cestas con gancho para CPT-64  
cm. 30x 33x 25h



**103,00**  
3 / 0,04

**531071900 GRIGLIA SUPPORTO CESTI CON GANCIO PER CPT-66**  
EN support for baskets with hook for CPT-66 • DE Unterstützung für Körbe mit Haken für CPT-66 • FR soutien pour les paniers avec crochet pour CPT-66 • ES soporte para cestas con gancho para CPT-66  
cm. 50x 30x 25h

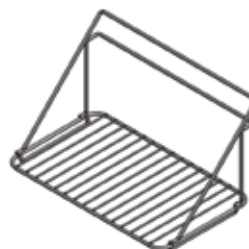

**131,00**  
3,5 / 0,06

**531013200 CESTO 1/2 PER F13-64E / F10T-63E**  
EN Basket 1/2 for F13-64E / F10T-63E • DE Korb 1/2 für F13-64E / F10T-63E • FR Panier 1/2 pour F13-64E / F10T-63E • ES Cesta 1/2 para F13-64E / F10T-63E  
cm. 10x 30x 12h



**47,00**  
0,7 / 0,03

**531053300 CESTO 1/2 PER F13-64G**  
EN Basket 1/2 for F13-64G • DE Korb 1/2 für F13-64G • FR Panier 1/2 pour F13-64G • ES Cesta 1/2 para F13-64G  
cm. 15x 27x 12h

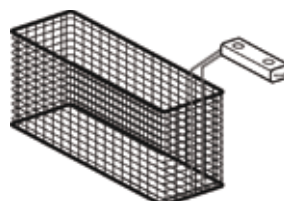

**63,00**  
0,7 / 0,04

MOD. \_\_\_\_\_  
COD. \_\_\_\_\_

DESCRIZIONE/DESCRIPTION/BEZEICHNUNG/DESCRIPTION/DESCRIPCIÓN  
DIMENSIONI/DIMENSIONS/ABMESSUNGEN/DIMENSIONS/DIMENSIONES

POTENZA/POWER/LEISTUNG/PUISSANCE/POTENCIA  
VOLTAGGIO/VOLTAGE/SPANNUNG/VOLTAGE/VOLTAJE

⚡ kcal/h  
⚡ kw  
V~  
Hz

PREZZO/PRICE €  
PREIS/PRIX/PRECIO €  
KG / M<sup>3</sup>

<b>SA-62</b> 06600200	<b>SCHIENA POSTERIORE A VISTA PER APPARECCHI</b> <b>EN</b> Back cover • <b>DE</b> Ruckenwand • <b>FR</b> Dos de finition • <b>ES</b> panel posterior <b>cm. 20x 1,5x 81h</b>		<b>83,00</b> 2 / 0,01
<b>SA-63</b> 06600300	<b>cm. 30x 1,5x 81h</b>		<b>94,00</b> 3 / 0,01
<b>SA-64</b> 06600400	<b>cm. 40x 1,5x 81h</b>		<b>108,00</b> 3 / 0,01
<b>SA-66</b> 06600600	<b>cm. 60x 1,5x 81h</b>		<b>156,00</b> 4 / 0,02
<b>SA-68</b> 06600800	<b>cm. 80x 1,5x 81h</b>		<b>183,00</b> 5 / 0,02
<b>SA-610</b> 06601000	<b>cm. 100x 1,5x 81h</b>		<b>228,00</b> 6 / 0,03
<b>SA-612</b> 06601200	<b>cm. 120x 1,5x 81h</b>		<b>274,00</b> 7 / 0,03
<b>SA-63FG</b> 06600301	<b>SCHIENA POSTERIORE A VISTA PER FRIGGITRICI GAS</b> <b>EN</b> Back cover for Gas Fryer • <b>DE</b> Ruckenwand fur Gas-Friteuse • <b>FR</b> Dos de finition pour Friteuse a gaz • <b>ES</b> panel posterior para Freidoras a gas <b>cm. 30x 1,5x 90h</b>		<b>100,00</b> 3 / 0,01
<b>SA-66FG</b> 06600601	<b>cm. 60x 1,5x 90h</b>		<b>168,00</b> 4 / 0,02

**KIT-TOPM-SA KIT TAMPONAMENTI LATERALI PER SCHIENA POSTERIORE MONTATA SU APPARECCHI TOP E MOBILI "M-.."**

08600001

**EN** Side KIT for back cover mounted on the TOP machine and Stand "M-..". • **DE** Seitliches KIT fur Ruckenwand montiert auf der TOP-Maschine und Unterbau "M-..". • **FR** KIT latéral pour Dos de finition monté sur la machine TOP et Placard "M-..". • **ES** KIT lateral para panel posterior montado en la máquina TOP y Mueble base "M-..".

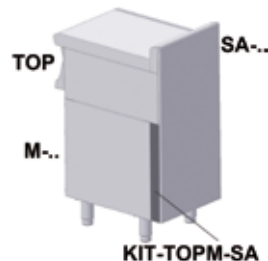

**73,00**  
1 / 0,01

**TMA-6SX TESTATA 1 LATO SERIE 60 SINISTRA**

06540601

**EN** Head 1 side S60 left • **DE** Abschluss element 1 seite S60 links • **FR** Element de jonction 1 coté S60 gauche  
• **ES** Embellecedor 1 lado S60 izquierda  
**cm. 0,2x 60**



**197,00**  
7 / 0,02

**TMA-6DX TESTATA 1 LATO SERIE 60 DESTRA**

06540600

**EN** Head 1 side S60 right • **DE** Abschluss element 1 seite S60 recht • **FR** Element de jonction 1 coté S60 droit  
• **ES** Embellecedor 1 lado S60 derecha  
**cm. 0,2x 60**



**197,00**  
7 / 0,02



Le immagini presentate non sono vincolanti. La ditta si riserva di apportare modifiche senza preavviso. • The pictures are purely representative. The manufacturer reserves the right to modify the technical data and models without previous notice. • Les images

**LO**

présentées ne nous engagent pas. La Société se réserve le droit d'apporter tout modification sans préavis. • Die dargestellten Abbildungen sind nicht verbindlich. Technische Änderungen vorbehalten. • Las imágenes presentadas no son vinculantes. El Fabricante se reserva el derecho de modificar sus productos sin previo aviso.

01/20

**67**

MOD. \_\_\_\_\_  
COD. \_\_\_\_\_

DESCRIZIONE/DESCRIPTION/BEZEICHNUNG/DESCRIPTION/DESCRIPCIÓN  
DIMENSIONI/DIMENSIONS/ABMESSUNGEN/DIMENSIONS/DIMENSIONES

POTENZA/POWER/LEISTUNG/PUISSANCE/POTENCIA  
VOLTAGGIO/VOLTAGE/SPANNUNG/VOLTAGE/VOLTAJE

⚡ kW kcal/h  
⚡ kw V~ Hz

PREZZO/PRICE €  
PREIS/PRIX/PRECIO €  
KG / M<sup>3</sup>

**TMA-66**  
06546600

**TESTATA 2 LATI SERIE 60**  
**EN** Head 2 sides S60 • **DE** Abschluss element seiten S60 • **FR** Element de jonction 2 cotés S60 • **ES** Embellecedor 2 lados S60  
**cm. 0,2x 120**



**394,00**  
14 / 0,04

**TMA-67SX**  
06546701

**TESTATA 2 LATI SERIE 60/70 SINISTRA**  
**EN** Head 2 sides S60/70 left • **DE** Abschluss element seiten S60/70 links • **FR** Element de jonction 2 cotés S60/70 gauche • **ES** Embellecedor 2 lados S60/70 izquierda  
**cm. 0,2x 130,5**



**404,00**  
15 / 0,04

**TMA-67DX**  
06546700

**TESTATA 2 LATI SERIE 60/70 DESTRA**  
**EN** Head 2 sides S60/70 right • **DE** Abschluss element seiten S60/70 recht • **FR** Element de jonction 2 cotés S60/70 droit • **ES** Embellecedor 2 lados S60/70 derecha  
**cm. 0,2x 130,5**



**404,00**  
15 / 0,04

**TMA-69SX**  
06546901

**TESTATA 2 LATI SERIE 60/90 SINISTRA**  
**EN** Head 2 sides S60/90 left • **DE** Abschluss element seiten S60/90 links • **FR** Element de jonction 2 cotés S60/90 gauche • **ES** Embellecedor 2 lados S60/90 izquierda  
**cm. 0,2x 150**



**425,00**  
16 / 0,04

**TMA-69DX**  
06546900

**TESTATA 2 LATI SERIE 60/90 DESTRA**  
**EN** Head 2 sides S60/90 right • **DE** Abschluss element seiten S60/90 recht • **FR** Element de jonction 2 cotés S60/90 droit • **ES** Embellecedor 2 lados S60/90 derecha  
**cm. 0,2x 150**



**425,00**  
16 / 0,04

**BCC**  
16000000

**BLOCCO COTTURA CARRELLATO COMPOSTO**  
**DA:** BRS-161, F10T-63ET, PLT-64, TG-64, FTLRT-66ET, PLT-63, HP-4, TS-6  
**EN** Cooking unit on trolley - Made of: BRS-161, F10T-63ET, PLT-64, TG-64, FTLRT-66ET, PLT-63, HP-4, TS-6  
• **DE** Kochvorrichtung mit fahrbarem gestell Anbauteile: BRS-161, F10T-63ET, PLT-64, TG-64, FTLRT-66ET, PLT-63, HP-4, TS-6 • **FR** Bloc cuisson roulant - Elements de composition: BRS-161, F10T-63ET, PLT-64, TG-64, FTLRT-66ET, PLT63, HP-4, TS-6 • **ES** Bloque cocción con ruedas - Compuesto por: BRS-161, F10T-63ET, PLT-64, TG-64, FTLRT-66ET, PLT-63, HP-4, TS-6  
**cm. 220x 65x 110h**



⚡ 15,48 kW  
400V~3N  
230V~3  
50 Hz

**12.737,00**  
260 / 2,29





FINE KITCHEN



Tabella					
MOD. SP	INT 1	INT 2	-	MOD. PP	INT 3
SP/630	276		-	PP-630 SX/DX	190
SP/640	376		-	PP-640 SX/DX	290
SP/645	426		-	PP-645 SX/DX	340
SP/650	476		-	PP-650 SX/DX	390
SP/670	676		-	PP-660/PPS-660	490
SP/6105	1026		-	PP-670	590
SP/6110	1076		-	PP-680	690
SP/6125	1226		-	PP-690/PPS-690	790
SP/6135	1326		-	PP-6100	890
SP-SK/660		576	-	PP-6105	940
SP-SK/680		776	-	PP-6110	990
SP-SK/690		876	-	PP-6120	1090
SP-SK/6100		976	-	PP-6125	1140
SP-SK/6120		1176	-	PP-6135	1240
SP-SK/6140		1376	-	PP-6150	1390
SP-SK/6150		1476	-		
SP-SK/6160		1576	-		
SP-SK/6180		1776	-		
SP-SK/6200		1976	-		

# CASSETTIERE

MOD. \_\_\_\_\_  
COD. \_\_\_\_\_

DESCRIZIONE/DESCRIPTION/BEZEICHNUNG/DESCRIPTION/DESCRIPCIÓN  
DIMENSIONI/DIMENSIONS/ABMESSUNGEN/DIMENSIONS/DIMENSIONES

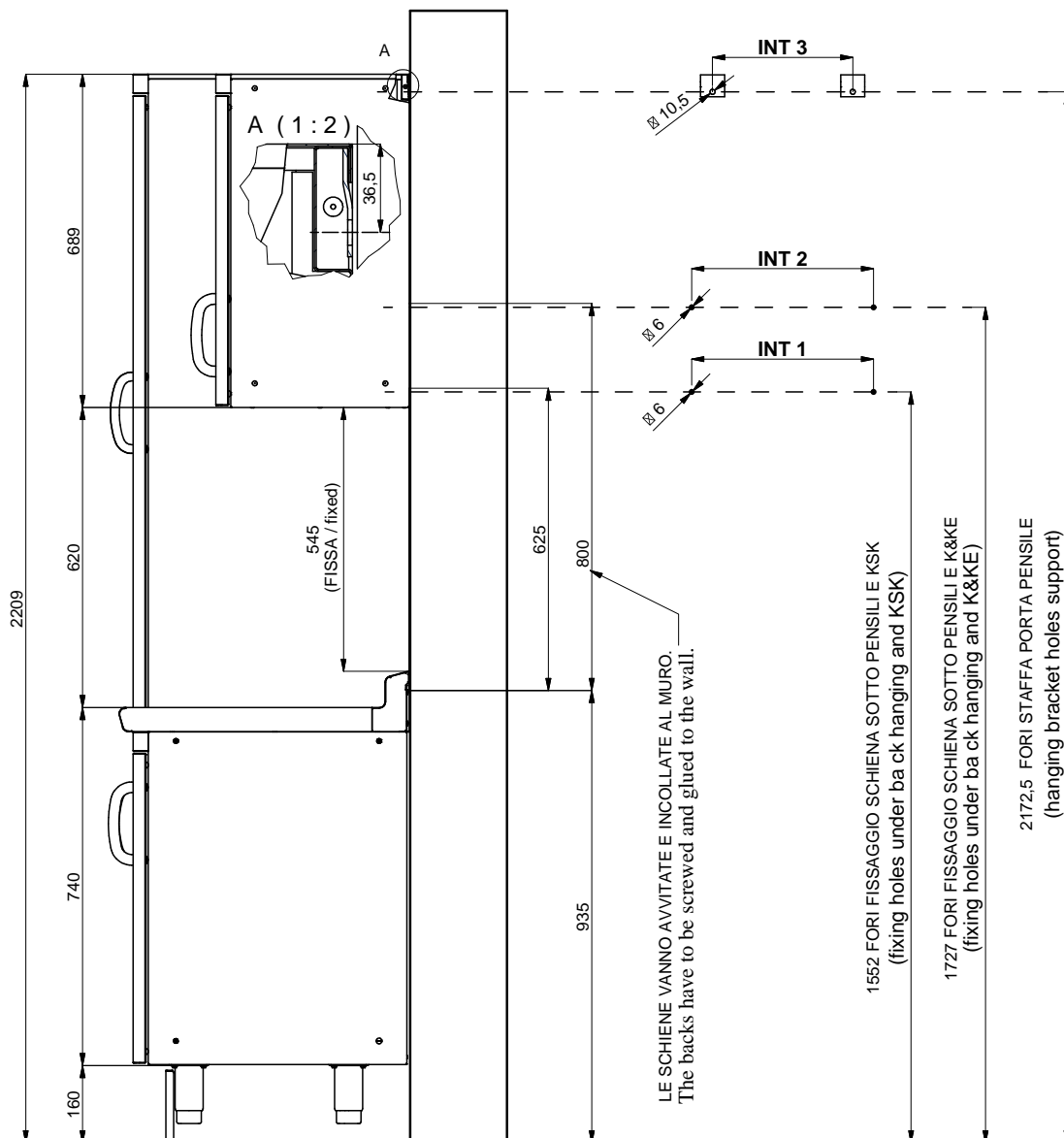
POTENZA/POWER/LEISTUNG/PUISSANCE/POTENCIA  
VOLTAGGIO/VOLTAGE/SPANNUNG/VOLTAGE/VOLTAJE

⚡ kW  
kcal/h

⚡ kw  
V~  
Hz

PREZZO/PRICE €  
PREIS/PRIX/PRECIO €  
KG / M<sup>3</sup>

**BC1/660**  
01070601

**1 CASSETTO CM.51,8X52X57,2**  
**EN** 1 DRAWER cm.51,8x52x57,2 • **DE** 1  
SCHUBLADEN cm.51,8x52x57,2 • **FR** 1 TIROIR  
cm.51,8x52x57,2 • **ES** 1 CAJONE cm.51,8x52x57,2  
**cm. 60x 56,6x 81h**

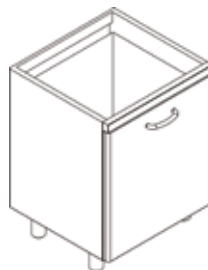

**1.059,00**  
41 / 0,40

**BC2/640**  
01070402

**2 CASSETTI CM.31,8X52X25**  
**EN** 2 DRAWERS cm.31,8x52x25 • **DE** 2 SCHUBLADEN  
cm.31,8x52x25 • **FR** 2 TIROIRS cm.31,8x52x25 • **ES**  
2 CAJONES cm.31,8x52x25  
**cm. 40x 56,6x 81h**

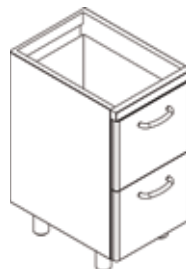

**990,00**  
35 / 0,28

**BC2/645**  
01070452

**2 CASSETTI CM.36,8X52X25**  
**EN** 2 DRAWERS cm.36,8x52x25 • **DE** 2 SCHUBLADEN  
cm.36,8x52x25 • **FR** 2 TIROIRS cm.36,8x52x25 • **ES**  
2 CAJONES cm.36,8x52x25  
**cm. 45x 56,6x 81h**



**1.093,00**  
37.5 / 0,31

**BC2/650**  
01070502

**2 CASSETTI CM.41,8X52X25**  
**EN** 2 DRAWERS cm.41,8x52x25 • **DE** 2 SCHUBLADEN  
cm.41,8x52x25 • **FR** 2 TIROIRS cm.41,8x52x25 • **ES**  
2 CAJONES cm.41,8x52x25  
**cm. 50x 56,6x 81h**

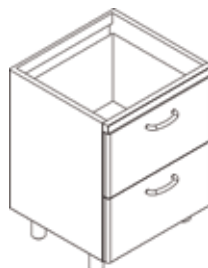

**1.178,00**  
40 / 0,34

**BC2/660**  
01070602

**2 CASSETTI CM.51,8X52X25**  
**EN** 2 DRAWERS cm.51,8x52x25 • **DE** 2 SCHUBLADEN  
cm.51,8x52x25 • **FR** 2 TIROIRS cm.51,8x52x25 • **ES**  
2 CAJONES cm.51,8x52x25  
**cm. 60x 56,6x 81h**



**1.254,00**  
44 / 0,40

**BC3/640**  
01070403

**3 CASSETTI CM.31,8X52X14,3**  
**EN** 3 DRAWERS cm.31,8x52x14,3 • **DE** 3  
SCHUBLADEN cm.31,8x52x14,3 • **FR** 3 TIROIRS  
cm.31,8x52x14,3 • **ES** 3 CAJONES cm.31,8x52x14,3  
**cm. 40x 56,6x 81h**



**1.026,00**  
39 / 0,28

**BC3/645**  
01070453

**3 CASSETTI CM.36,8X52X14,3**  
**EN** 3 DRAWERS cm.36,8x52x14,3 • **DE** 3  
SCHUBLADEN cm.36,8x52x14,3 • **FR** 3 TIROIRS  
cm.36,8x52x14,3 • **ES** 3 CAJONES cm.36,8x52x14,3  
**cm. 45x 56,6x 81h**



**1.238,00**  
41.5 / 0,31

**BC3/650**  
01070503

**3 CASSETTI CM.41,8X52X14,3**  
**EN** 3 DRAWERS cm.41,8x52x14,3 • **DE** 3  
SCHUBLADEN cm.41,8x52x14,3 • **FR** 3 TIROIRS  
cm.41,8x52x14,3 • **ES** 3 CAJONES cm.41,8x52x14,3  
**cm. 50x 56,6x 81h**



**1.328,00**  
43 / 0,34

**BC4/630**  
01070304

**4 CASSETTI CM.21,8X52X8,9**  
**EN** 4 DRAWERS cm.21,8x52x8,9 • **DE** 4  
SCHUBLADEN cm.21,8x52x8,9 • **FR** 4 TIROIRS  
cm.21,8x52x8,9 • **ES** 4 CAJONES cm.21,8x52x8,9  
**cm. 30x 56,6x 81h**

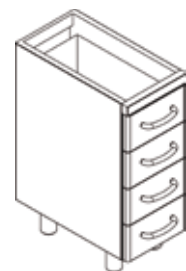

**1.093,00**  
37 / 0,22

FINE KITCHEN



Le immagini presentate non sono vincolanti. La ditta si riserva di apportare modifiche senza preavviso. • The pictures are purely representative. The manufacturer reserves the right to modify the technical data and models without previous notice. • Les images

LO

présentées ne nous engagent pas. La Société se réserve le droit d'apporter tout modification sans préavis. • Die dargestellten Abbildungen sind nicht verbindlich. Technische Änderungen vorbehalten. • Las imágenes presentadas no son vinculantes. El Fabricante se reserva el derecho de modificar sus productos sin previo aviso.

01/20

71

# CASSETTIERE

MOD. \_\_\_\_\_  
COD. \_\_\_\_\_

DESCRIZIONE/DESCRIPTION/BEZEICHNUNG/DESCRIPTION/DESCRIPCIÓN  
DIMENSIONI/DIMENSIONS/ABMESSUNGEN/DIMENSIONS/DIMENSIONES

POTENZA/POWER/LEISTUNG/PUISSANCE/POTENCIA  
VOLTAGGIO/VOLTAGE/SPANNUNG/VOLTAGE/VOLTAJE

⚡ kW kcal/h  
⚡ kw V~ Hz

PREZZO/PRICE €  
PREIS/PRIX/PRECIO €  
KG / M<sup>3</sup>

**BC4/640** **4 CASSETTI CM.31,8X52X8,9**  
01070404 **EN** 4 DRAWERS cm.31,8x52x8,9 • **DE** 4 SCHUBLADEN cm.31,8x52x8,9 • **FR** 4 TIROIRS cm.31,8x52x8,9 • **ES** 4 CAJONES cm.31,8x52x8,9  
**cm. 40x 56,6x 81h**



**1.162,00**  
42 / 0,28

**BC4/645** **4 CASSETTI CM.36,8X52X8,9**  
01070454 **EN** 4 DRAWERS cm.36,8x52x8,9 • **DE** 4 SCHUBLADEN cm.36,8x52x8,9 • **FR** 4 TIROIRS cm.36,8x52x8,9 • **ES** 4 CAJONES cm.36,8x52x8,9  
**cm. 45x 56,6x 81h**

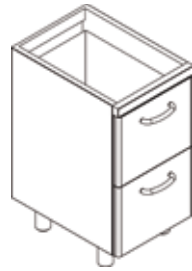

**1.383,00**  
43.5 / 0,31

**BC2B/640** **2 BACINELLE INOX GN 1/1 H20**  
01080402 **EN** 2 CONTAINERS INOX GN 1/1 h20 • **DE** 2 BEHALTERN INOX GN 1/1 h20 • **FR** 2 BACS INOX GN 1/1 h20 • **ES** 2 CONTENEDORES INOX GN 1/1 h20  
**cm. 40x 56,6x 81h**

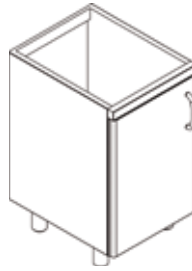

**1.113,00**  
34 / 0,28

**BP/630SX** **BASE CON PORTA E RIPIANO INTERMEDIO**  
01010301 **EN** STORAGE UNIT WITH DOOR AND MIDDLE SHELF • **DE** FLUGELTURELEMENT MIT ZWISCHENBORD • **FR** ELEMENT DE BASE AVEC PORTE ET ETAGERE INTERMEDIAIRE • **ES** BASE CON PUERTA Y ESTANTE INTERMEDIO  
**cm. 30x 56,6x 81h**



**566,00**  
18 / 0,22

**BP/640SX** **cm. 40x 56,6x 81h**  
01010401

**580,00**  
21 / 0,28

**BP/645SX** **cm. 45x 56,6x 81h**  
01010451

**608,00**  
22.5 / 0,31

**BP/650SX** **cm. 50x 56,6x 81h**  
01010501

**616,00**  
24 / 0,34

**BP/630DX** **cm. 30x 56,6x 81h**  
01010300

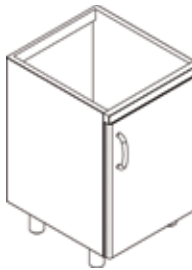

**566,00**  
18 / 0,22

**BP/640DX** **cm. 40x 56,6x 81h**  
01010400

**580,00**  
21 / 0,28

**BP/645DX** **cm. 45x 56,6x 81h**  
01010450

**608,00**  
22.5 / 0,31

**BP/650DX** **cm. 50x 56,6x 81h**  
01010500

**616,00**  
24 / 0,34

**BP/660** **BASE CON PORTE, GUARNIZIONE E RIPIANO INTERMEDIO**  
01010600 **EN** STORAGE UNIT WITH DOORS , GASKET AND MIDDLE SHELF • **DE** FLUGELTURELEMENT MIT TURDICHTUNG UND ZWISCHENBORD • **FR** ELEMENT DE BASE AVEC PORTES , JOINT ET ETAGERE INTERMEDIAIRE • **ES** BASE CON PUERTAS, GUARNICION Y ESTANTE INTERMEDIO  
**cm. 60x 56,6x 81h**

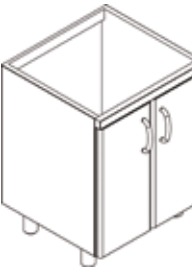

**811,00**  
28 / 0,40

**BP/670** **cm. 70x 56,6x 81h**  
01010700

**843,00**  
32 / 0,46

FINE KITCHEN

# MOBILI BASE



MOD. \_\_\_\_\_  
COD. \_\_\_\_\_

DESCRIZIONE/DESCRIPTION/BEZEICHNUNG/DESCRIPTION/DESCRIPCIÓN  
DIMENSIONI/DIMENSIONS/ABMESSUNGEN/DIMENSIONS/DIMENSIONES

POTENZA/POWER/LEISTUNG/PUISSANCE/POTENCIA  
VOLTAGGIO/VOLTAGE/SPANNUNG/VOLTAGE/VOLTAJE

⚡ kW kcal/h  
⚡ kw V~ Hz

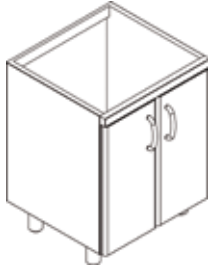
PREZZO/PRICE €  
PREIS/PRIX/PRECIO €  
KG / M<sup>3</sup>

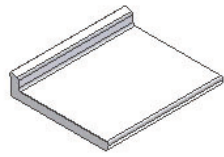
<b>BP/680</b> 01010800	cm. 80x 56,6x 81h		<b>880,00</b> 36 / 0,51
<b>BP/690</b> 01010900	cm. 90x 56,6x 81h		<b>936,00</b> 39 / 0,57
<b>BP/6100</b> 01011000	cm. 100x 56,6x 81h		<b>983,00</b> 42 / 0,63
<b>BP/6105</b> 01011050	<b>BASE CON 3 PORTE, GUARNIZIONI E RIPIANO INTERMEDIO</b> <b>EN</b> STORAGE UNIT WITH 3 DOORS , GASKETS AND MIDDLE SHELF • <b>DE</b> FLUGELTUELEMENT MIT 3 TUREN, TURDICHTUNGEN UND ZWISCHENBORD • <b>FR</b> ELEMENT DE BASE AVEC 3 PORTES , JOINTS ET ETAGERE INTERMEDIAIRE • <b>ES</b> BASE CON 3 PUERTAS, GUARNICION Y ESTANTE INTERMEDIO cm. 105x 56,6x 81h		<b>1.171,00</b> 43.5 / 0,66
<b>BP/6110</b> 01011100	cm. 110x 56,6x 81h		<b>1.194,00</b> 45 / 0,69
<b>BP/6120</b> 01011200	cm. 120x 56,6x 81h		<b>1.238,00</b> 48 / 0,75
<b>BP/6125</b> 01011250	cm. 125x 56,6x 81h		<b>1.260,00</b> 49.5 / 0,78
<b>BP/6135</b> 01011350	cm. 135x 56,6x 81h		<b>1.307,00</b> 52.5 / 0,83
<b>BP/6150</b> 01011500	cm. 150x 56,6x 81h		<b>1.377,00</b> 57 / 0,92
<b>BPA/680</b> 01110801	<b>BASE AD ANGOLO CON PORTA E RIPIANO INTERMEDIO</b> <b>EN</b> CORNER STORAGE UNIT WITH DOOR AND MIDDLE SHELF • <b>DE</b> ECK-ELEMENT 90° MIT TUR UND ZWISCHENBORD • <b>FR</b> ELEMENT DE BASE D'ANGLE AVEC PORTE ET ETAGERE INTERMEDIAIRE • <b>ES</b> BASE ANGULAR CON PUERTA Y ENTANTE INTERMEDIO cm.80/80x 56,6x 81h		<b>1.118,00</b> 41 / 0,70
<b>PL/630</b> 01310300	<b>PIANO LAVORO CON ALZATINA E BORDO FRONTALE ARROTONDATO</b> <b>EN</b> WORKTOP WITH RAISED AND REAR BORDER • <b>DE</b> OBERPLATTE MIT AUFKANTUNG HINTEN UND PROFILE ABGERUNDET. • <b>FR</b> PLAN DE TRAVAIL AVEC JOINT DE FINITION POSTERIEUR ET BORDE FRONTAL TOMBE' • <b>ES</b> SOBRE DE TRABAJO CON PETO TRASERO Y BORDE FRONTAL REDONDEADO cm. 30x 60x 5h		<b>159,00</b> 5,5 / 0,05
<b>PL/640</b> 01310400	cm. 40x 60x 5h		<b>182,00</b> 7,5 / 0,06
<b>PL/645</b> 01310450	cm. 45x 60x 5h		<b>205,00</b> 8,5 / 0,07
<b>PL/650</b> 01310500	cm. 50x 60x 5h		<b>216,00</b> 9 / 0,08



# PIANI LAVORO

MOD. \_\_\_\_\_  
COD. \_\_\_\_\_

DESCRIZIONE/DESCRIPTION/BEZEICHNUNG/DESCRIPTION/DESCRIPCIÓN  
DIMENSIONI/DIMENSIONS/ABMESSUNGEN/DIMENSIONS/DIMENSIONES

POTENZA/POWER/LEISTUNG/PUISSANCE/POTENCIA  
VOLTAGGIO/VOLTAGE/SPANNUNG/VOLTAGE/VOLTAJE

$\frac{kW}{kcal/h}$   $\frac{V}{Hz}$

PREZZO/PRICE €  
PREIS/PRIX/PRECIO €  
KG / M<sup>3</sup>

MOD. / COD.	DESCRIZIONE / DIMENSIONI	POTENZA / VOLTAGGIO	PREZZO / PRICE
PL/660 01310600	cm. 60x 60x 5h		226,00 11 / 0,09
PL/670 01310700	cm. 70x 60x 5h		250,00 13 / 0,10
PL/675 01310750	cm. 75x 60x 5h		260,00 13.5 / 0,11
PL/680 01310800	cm. 80x 60x 5h		284,00 14,5 / 0,11
PL/690 01310900	cm. 90x 60x 5h		294,00 16,5 / 0,13
PL/6100 01311000	cm. 100x 60x 5h		307,00 18,5 / 0,14
PL/6105 01311050	cm. 105x 60x 5h		318,00 19,5 / 0,15
PL/6110 01311100	cm. 110x 60x 5h		329,00 20 / 0,15
PL/6120 01311200	cm. 120x 60x 5h		340,00 22 / 0,17
PL/6125 01311250	cm. 125x 60x 5h		352,00 23 / 0,17
PL/6130 01311300	cm. 130x 60x 5h		363,00 24 / 0,18
PL/6135 01311350	cm. 135x 60x 5h		374,00 24,5 / 0,19
PL/6140 01311400	cm. 140x 60x 5h		407,00 25,5 / 0,19
PL/6150 01311500	cm. 150x 60x 5h		431,00 27,5 / 0,21
PL/6160 01311600	cm. 160x 60x 5h		453,00 29,5 / 0,22
PL/6165 01311650	cm. 165x 60x 5h		476,00 30,5 / 0,23
PL/6180 01311800	cm. 180x 60x 5h		510,00 33 / 0,24
PL/6195 01311950	cm. 195x 60x 5h		555,00 35,5 / 0,26
PL/6200 01312000	cm. 200x 60x 5h		578,00 36,5 / 0,27

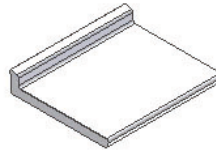

FINE KITCHEN

# PIANI LAVORO

MOD. \_\_\_\_\_  
COD. \_\_\_\_\_

DESCRIZIONE/DESCRIPTION/BEZEICHNUNG/DESCRIPTION/DESCRIPCIÓN  
DIMENSIONI/DIMENSIONS/ABMESSUNGEN/DIMENSIONS/DIMENSIONES

POTENZA/POWER/LEISTUNG/PUISSANCE/POTENCIA  
VOLTAGGIO/VOLTAGE/SPANNUNG/VOLTAGE/VOLTAJE

⚡ kW kcal/h  
⚡ kw V~ Hz

PREZZO/PRICE €  
PREIS/PRIX/PRECIO €  
KG / M<sup>3</sup>

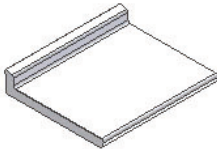
<b>PL/6210</b> 01312100	<b>cm. 210x 60x 5h</b>		<b>600,00</b> 38,5 / 0,28
<b>PL/6220</b> 01312200	<b>cm. 220x 60x 5h</b>		<b>624,00</b> 40,5 / 0,30
<b>PL/6225</b> 01312250	<b>cm. 225x 60x 5h</b>		<b>657,00</b> 41,5 / 0,30
<b>PL/6240</b> 01312400	<b>cm. 240x 60x 5h</b>		<b>702,00</b> 44 / 0,32

<b>PLA/680</b> 01320800	<b>PIANO LAVORO AD ANGOLO CON ALZATINA E BORDO FRONTALE ARROTONDATO</b> <b>EN CORNER WORKTOP WITH RAISED AND REAR BORDER • DE OBERPLATTE ECK-ELEMENT 90° MIT 75mm AUFKANTUNG HINTEN UND PROFILE ABGERUNDET. • FR PLAN DE TRAVAIL D'ANGLE AVEC JOINT DE FINITION POSTERIEUR ET BORD FRONTAL TOMBE' • ES SOBRE DE TRABAJO ANGULAR CON PETO TRASERO Y BORDE FRONTAL REDONDEADO</b> <b>cm.80/80x 60x 5h</b>		<b>450,00</b> 18 / 0,16
----------------------------	---	--	----------------------------

<b>BPL/645SX</b> 01030451	<b>BASE PER LAVELLO CON PORTA</b> <b>EN STORAGE UNIT FOR SINK WITH DOOR • DE FLUGELTURELEMENT FUR SPULBECKEN • FR ELEMENT DE BASE POUR EVIER AVEC PORTE • ES BASE PARA FREGADERO CON PUERTA</b> <b>cm. 45x 56,6x 81h</b>		<b>575,00</b> 20.5 / 0,31
------------------------------	--	---	------------------------------

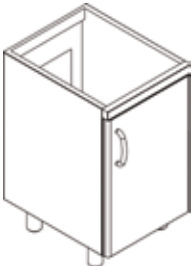
<b>BPL/645DX</b> 01030450	<b>cm. 45x 56,6x 81h</b>		<b>575,00</b> 20.5 / 0,31
------------------------------	--------------------------	--	------------------------------

<b>BPL/660</b> 01030600	<b>BASE PER LAVELLO CON PORTE</b> <b>EN STORAGE UNIT FOR SINK WITH 2 DOORS • DE FLUGELTURELEMENT FUR SPULBECKEN • FR ELEMENT DE BASE POUR EVIER AVEC 2 PORTES • ES BASE PARA FREGADERO CON PUERTAS</b> <b>cm. 60x 56,6x 81h</b>		<b>775,00</b> 26 / 0,40
----------------------------	---	--	----------------------------

<b>BPL/690</b> 01030900	<b>cm. 90x 56,6x 81h</b>		<b>880,00</b> 37 / 0,57
----------------------------	--------------------------	--	----------------------------

FINE KITCHEN



Le immagini presentate non sono vincolanti. La ditta si riserva di apportare modifiche senza preavviso. • The pictures are purely representative. The manufacturer reserves the right to modify the technical data and models without previous notice. • Les images

LO

présentées ne nous engagent pas. La Société se réserve le droit d'apporter tout modification sans préavis. • Die dargestellten Abbildungen sind nicht verbindlich. Technische Änderungen vorbehalten. • Las imágenes presentadas no son vinculantes. El Fabricante se reserva el derecho de modificar sus productos sin previo aviso.

01/20

75

# MOBILI BASE LAVELLO

MOD. \_\_\_\_\_  
COD. \_\_\_\_\_

DESCRIZIONE/DESCRIPTION/BEZEICHNUNG/DESCRIPTION/DESCRIPCIÓN  
DIMENSIONI/DIMENSIONS/ABMESSUNGEN/DIMENSIONS/DIMENSIONES

POTENZA/POWER/LEISTUNG/PUISSANCE/POTENCIA  
VOLTAGGIO/VOLTAGE/SPANNUNG/VOLTAGE/VOLTAJE

↓ kW kcal/h  
↑ kW V~ Hz

PREZZO/PRICE €  
PREIS/PRIX/PRECIO €  
KG / M<sup>3</sup>

**BPL/6105** **BASE PER LAVELLO CON 3 PORTE**  
01031050 **EN** STORAGE UNIT FOR SINK WITH 3 DOORS • **DE** FLUGELTURELEMENT FÜR SPULBECKEN • **FR** ELEMENT DE BASE POUR EVIER AVEC 3 PORTES • **ES** BASE PARA FREGADERO CON 3 PUERTAS  
**cm. 105x 56,6x 81h**



**911,00**  
41.5 / 0,66

**BPL/6120** **cm. 120x 56,6x 81h**  
01031200

**1.150,00**  
45 / 0,75

**BPL/6135** **cm. 135x 56,6x 81h**  
01031350

**1.201,00**  
49.5 / 0,83

**BPL/6150** **cm. 150x 56,6x 81h**  
01031500

**1.250,00**  
54 / 0,92

**BPAL/680** **BASE PER LAVELLO AD ANGOLO CON PORTA**  
01130800 **EN** CORNER STORAGE UNIT FOR SINK WITH DOOR  
• **DE** ECK-ELEMENT 90° FÜR ECKSPULABDECKUNG  
MIT FLUGELTURE • **FR** ELEMENT DE BASE D'ANGLE  
POUR EVIER AVEC PORTE • **ES** BASE ANGULAR PARA  
FREGADERO CON PUERTA  
**cm.80/80x 56,6x 81h**

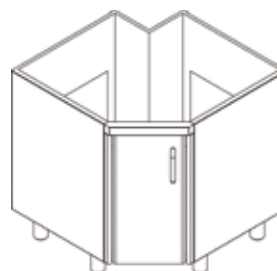

**1.134,00**  
37 / 0,70

**L/645** **1 VASCA CM.29X35X14H**  
01330450 **EN** 1 BOWL cm.29x35x14h • **DE** 1 BECKEN  
cm.29x35x14h • **FR** 1 BAC cm.29x35x14h • **ES** 1  
CUBA cm.29x35x14h  
**cm. 45x 60x 5h**

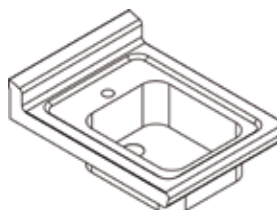

**340,00**  
9.5 / 0,12

**L/660** **1 VASCA CM.34X39X19,5H**  
01330600 **EN** 1 BOWL cm.34x39x19,5h • **DE** 1 BECKEN  
cm.34x39x19,5h • **FR** 1 BAC cm.34x39x19,5h • **ES** 1  
CUBA cm.34x39x19,5h  
**cm. 60x 60x 5h**

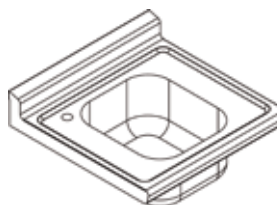

**417,00**  
12 / 0,15

**L/691 SX** **1 VASCA SX CM.34X39X19,5H CON**  
01330902 **SGOCCIOLATOIO**  
**EN** 1 BOWL LEFT cm.34x39x19,5h WITH DRAINING  
BOARD • **DE** 1 BECKEN LINKS cm.34x39x19,5h  
MIT ABTROPFFLACHE • **FR** 1 BAC A GAUCHE  
cm.34x39x19,5h AVEC EGOUTTOIR • **ES** 1 CUBA A  
LA IZQ. cm.34x39x19,5h CON ESCURRIDOR  
**cm. 90x 60x 5h**

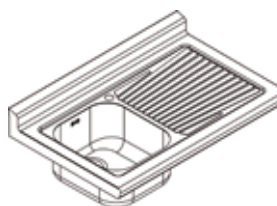

**507,00**  
18.5 / 0,22

**L/691 DX** **1 VASCA DX CM.34X39X19,5H CON**  
01330901 **SGOCCIOLATOIO**  
**EN** 1 BOWL RIGHT cm.34x39x19,5h WITH DRAINING  
BOARD • **DE** 1 BECKEN RECHT cm.34x39x19,5h  
MIT ABTROPFFLACHE • **FR** 1 BAC A DROITE  
cm.34x39x19,5h AVEC EGOUTTOIR • **ES** 1 CUBA A  
LA DERECHA cm.34x39x19,5h CON ESCURRIDOR  
**cm. 90x 60x 5h**

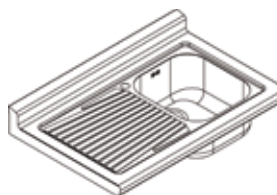

**507,00**  
18.5 / 0,22

MOD. \_\_\_\_\_  
COD. \_\_\_\_\_

DESCRIZIONE/DESCRIPTION/BEZEICHNUNG/DESCRIPTION/DESCRIPCIÓN  
DIMENSIONI/DIMENSIONS/ABMESSUNGEN/DIMENSIONS/DIMENSIONES

POTENZA/POWER/LEISTUNG/PUISSANCE/POTENCIA  
VOLTAGGIO/VOLTAGE/SPANNUNG/VOLTAGE/VOLTAJE

⚡ kW kcal/h  
⚡ kw V~ Hz

PREZZO/PRICE €  
PREIS/PRIX/PRECIO €  
KG / M<sup>3</sup>

**L/692**  
01330905

**2 VASCHE CM.34X39X19,5H**  
**EN** 2 BOWLS cm.34x39x19,5h • **DE** 2 BECKEN cm.34x39x19,5h • **FR** 2 BACS cm.34x39x19,5h • **ES** 2 CUBAS cm.34x39x19,5h  
**cm. 90x 60x 5h**

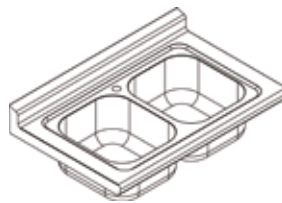

**616,00**  
18.5 / 0,22

**L/6105SX**  
01331052

**1 VASCA SX CM.34X39X19,5H CON SGOCCIOLATOIO**  
**EN** 1 BOWL LEFT cm.34x39x19,5h WITH DRAINING BOARD • **DE** 1 BECKEN LINKS cm.34x39x19,5h MIT ABTROPFFLACHE • **FR** 1 BAC A GAUCHE cm.34x39x19,5h AVEC EGOUTTOIR • **ES** 1 CUBA A LA IZQ. cm.34x39x19,5h CON ESCURRIDOR  
**cm. 105x 60x 5h**

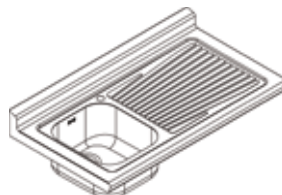

**557,00**  
21,5 / 0,25

**L/6105DX**  
01331051

**1 VASCA DX CM.34X39X19,5H CON SGOCCIOLATOIO**  
**EN** 1 BOWL RIGHT cm.34x39x19,5h WITH DRAINING BOARD • **DE** 1 BECKEN RECHT cm.34x39x19,5h MIT ABTROPFFLACHE • **FR** 1 BAC A DROITE cm.34x39x19,5h AVEC EGOUTTOIR • **ES** 1 CUBA A LA DERECHA cm.34x39x19,5h CON ESCURRIDOR  
**cm. 105x 60x 5h**

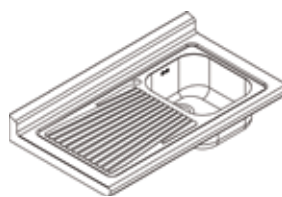

**557,00**  
21,5 / 0,25

**L/6121SX**  
01331202

**1 VASCA SX CM.34X39X19,5H CON SGOCCIOLATOIO**  
**EN** 1 BOWL LEFT cm.34x39x19,5h WITH DRAINING BOARD • **DE** 1 BECKEN LINKS cm.34x39x19,5h MIT ABTROPFFLACHE • **FR** 1 BAC A GAUCHE cm.34x39x19,5h AVEC EGOUTTOIR • **ES** 1 CUBA A LA IZQ. cm.34x39x19,5h CON ESCURRIDOR  
**cm. 120x 60x 5h**



**613,00**  
24 / 0,28

**L/6121DX**  
01331201

**1 VASCA DX CM.34X39X19,5H CON SGOCCIOLATOIO**  
**EN** 1 BOWL RIGHT cm.34x39x19,5h WITH DRAINING BOARD • **DE** 1 BECKEN RECHT cm.34x39x19,5h MIT ABTROPFFLACHE • **FR** 1 BAC A DROITE cm.34x39x19,5h AVEC EGOUTTOIR • **ES** 1 CUBA A LA DERECHA cm.34x39x19,5h CON ESCURRIDOR  
**cm. 120x 60x 5h**



**613,00**  
24 / 0,28

**L/6122SX**  
01331204

**2 VASCHE SX CM.34X39X19,5H CON SGOCCIOLATOIO**  
**EN** 2 BOWLS LEFT cm.34x39x19,5h WITH DRAINING BOARD • **DE** 2 BECKEN LINKS cm.34x39x19,5h MIT ABTROPFFLACHE • **FR** 2 BACS A GAUCHE cm.34x39x19,5h AVEC EGOUTTOIR • **ES** 2 CUBAS A LA IZQ. cm.34x39x19,5h CON ESCURRIDOR  
**cm. 120x 60x 5h**



**728,00**  
25 / 0,28

**L/6122DX**  
01331203

**2 VASCHE DX CM.34X39X19,5H CON SGOCCIOLATOIO**  
**EN** 2 BOWLS RIGHT cm.34x39x19,5h WITH DRAINING BOARD • **DE** 2 BECKEN RECHT cm.34x39x19,5h MIT ABTROPFFLACHE • **FR** 2 BACS A DROITE cm.34x39x19,5h AVEC EGOUTTOIR • **ES** 2 CUBAS A LA DERECHA cm.34x39x19,5h CON ESCURRIDOR  
**cm. 120x 60x 5h**



**728,00**  
25 / 0,28

**L/6135SX**  
01331354

**2 VASCHE SX CM.34X39X19,5H CON SGOCCIOLATOIO**  
**EN** 2 BOWLS LEFT cm.34x39x19,5h WITH DRAINING BOARD • **DE** 2 BECKEN LINKS cm.34x39x19,5h MIT ABTROPFFLACHE • **FR** 2 BACS A GAUCHE cm.34x39x19,5h AVEC EGOUTTOIR • **ES** 2 CUBAS A LA IZQ. cm.34x39x19,5h CON ESCURRIDOR  
**cm. 135x 60x 5h**



**781,00**  
28 / 0,32

MOD. \_\_\_\_\_  
COD. \_\_\_\_\_

DESCRIZIONE/DESCRIPTION/BEZEICHNUNG/DESCRIPTION/DESCRIPCIÓN  
DIMENSIONI/DIMENSIONS/ABMESSUNGEN/DIMENSIONS/DIMENSIONES

POTENZA/POWER/LEISTUNG/PUISSANCE/POTENCIA  
VOLTAGGIO/VOLTAGE/SPANNUNG/VOLTAGE/VOLTAJE

⚡ kW kcal/h  
⚡ kw V~ Hz

PREZZO/PRICE €  
PREIS/PRIX/PRECIO €  
KG / M<sup>3</sup>

**L/6135DX**  
01331353

**2 VASCHE DX CM.34X39X19,5H CON SGOCCIOLATOIO**  
**EN** 2 BOWLS RIGHT cm.34x39x19,5h WITH DRAINING BOARD • **DE** 2 BECKEN RECHT cm.34x39x19,5h MIT ABTROPFFLACHE • **FR** 2 BACS A DROITE cm.34x39x19,5h AVEC EGOUTTOIR • **ES** 2 CUBAS A LA DERECHA cm.34x39x19,5h CON ESCURRIDOR  
**cm. 135x 60x 5h**



**781,00**  
28 / 0,32

**L/6150SX**  
01331504

**2 VASCHE SX CM.34X39X19,5H CON SGOCCIOLATOIO**  
**EN** 2 BOWLS LEFT cm.34x39x19,5h WITH DRAINING BOARD • **DE** 2 BECKEN LINKS cm.34x39x19,5h MIT ABTROPFFLACHE • **FR** 2 BACS A GAUCHE cm.34x39x19,5h AVEC EGOUTTOIR • **ES** 2 CUBAS A LA IZQ. cm.34x39x19,5h CON ESCURRIDOR  
**cm. 150x 60x 5h**



**841,00**  
30.5 / 0,35

**L/6150DX**  
01331503

**2 VASCHE DX CM.34X39X19,5H CON SGOCCIOLATOIO**  
**EN** 2 BOWLS RIGHT cm.34x39x19,5h WITH DRAINING BOARD • **DE** 2 BECKEN RECHT cm.34x39x19,5h MIT ABTROPFFLACHE • **FR** 2 BACS A DROITE cm.34x39x19,5h AVEC EGOUTTOIR • **ES** 2 CUBAS A LA DERECHA cm.34x39x19,5h CON ESCURRIDOR  
**cm. 150x 60x 5h**



**841,00**  
30.5 / 0,35

**LA/680**  
01340800

**1 VASCA CM.50X40X20H**  
**EN** 1 BOWL cm.50x40x20h • **DE** 1 BECKEN cm.50x40x20h • **FR** 1 BAC cm.50x40x20h • **ES** 1 CUBA cm.50x40x20h  
**cm.80/80x 60x 5h**



**709,00**  
19 / 0,26

**PP/630SX**  
01210301

**PENSILE CON PORTA E RIPIANO INTERMEDIO**  
**EN** WALL UNIT WITH DOOR , AND MIDDLE SHELF • **DE** WANDHANGESCHRANK MIT TUR , UND ZWISCHENBORD • **FR** ARMOIRE SUSPENDUE AVEC PORTE ET ETAGERE INTERMEDIAIRE • **ES** ARMARIO DE PARED CON PUERTA Y ESTANTE INTERMEDIO  
**cm. 30x 40x 69h**

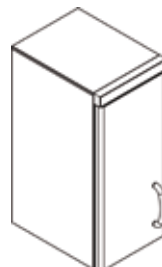

**525,00**  
16 / 0,17

**PP/640SX**  
01210401

**cm. 40x 40x 69h**

**541,00**  
19 / 0,21

**PP/645SX**  
01210451

**cm. 45x 40x 69h**

**556,00**  
20.5 / 0,23

**PP/650SX**  
01210501

**cm. 50x 40x 69h**

**572,00**  
22 / 0,25

**PP/630DX**  
01210300

**cm. 30x 40x 69h**

**525,00**  
16 / 0,17

**PP/640DX**  
01210400

**cm. 40x 40x 69h**

**541,00**  
19 / 0,21

**PP/645DX**  
01210450

**cm. 45x 40x 69h**

**556,00**  
20.5 / 0,23

**PP/650DX**  
01210500

**cm. 50x 40x 69h**

**572,00**  
22 / 0,25



MOD. \_\_\_\_\_  
COD. \_\_\_\_\_

DESCRIZIONE/DESCRIPTION/BEZEICHNUNG/DESCRIPTION/DESCRIPCIÓN  
DIMENSIONI/DIMENSIONS/ABMESSUNGEN/DIMENSIONS/DIMENSIONES

POTENZA/POWER/LEISTUNG/PUISSANCE/POTENCIA  
VOLTAGGIO/VOLTAGE/SPANNUNG/VOLTAGE/VOLTAJE

⚡ kW kcal/h  
⚡ kW V~ Hz

PREZZO/PRICE €  
PREIS/PRIX/PRECIO €  
KG / M<sup>3</sup>

**PP/660**  
01210600

**PENSILE CON PORTE, GUARNIZIONE E RIPIANO INTERMEDIO**  
**EN** WALL UNIT WITH DOORS , GASKET AND MIDDLE SHELF • **DE** WANDHANGESCHRANK MIT TUREN , TURDICHTUNGEN UND ZWISCHENBORD • **FR** ARMOIRE SUSPENDUE AVEC PORTES, JOINT DE PORTE ET ETAGERE INTERMEDIAIRE • **ES** ARMARIO DE PARED CON PUERTAS, GUARNICION Y ESTANTE INTERMEDIO  
**cm. 60x 40x 69h**

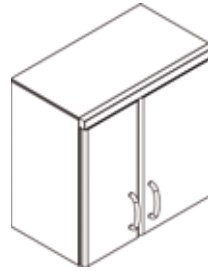

**719,00**  
26 / 0,30

**PP/670**  
01210700

**cm. 70x 40x 69h**

**748,00**  
29 / 0,34

**PP/680**  
01210800

**cm. 80x 40x 69h**

**778,00**  
33 / 0,38

**PP/690**  
01210900

**cm. 90x 40x 69h**

**822,00**  
36 / 0,43

**PP/6100**  
01211000

**cm. 100x 40x 69h**

**853,00**  
39 / 0,47

**PP/6105**  
01211050

**PENSILE CON 3 PORTE, GUARNIZIONI E RIPIANO INTERMEDIO**  
**EN** WALL UNIT WITH 3 DOORS , GASKET AND MIDDLE SHELF • **DE** WANDHANGESCHRANK MIT 3 TUREN , TURDICHTUNGEN UND ZWISCHENBORD • **FR** ARMOIRE SUSPENDUE AVEC 3 PORTES, JOINT DE PORTE ET ETAGERE INTERMEDIAIRE • **ES** ARMARIO DE PARED CON 3 PUERTAS, GUARNICION Y ESTANTE INTERMEDIO  
**cm. 105x 40x 69h**

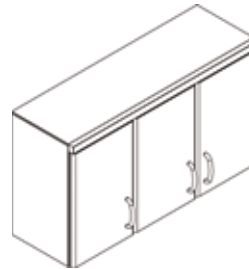

**1.024,00**  
40.5 / 0,49

**PP/6110**  
01211100

**cm. 110x 40x 69h**

**1.042,00**  
42 / 0,51

**PP/6120**  
01211200

**cm. 120x 40x 69h**

**1.073,00**  
45 / 0,56

**PP/6125**  
01211250

**cm. 125x 40x 69h**

**1.091,00**  
46.5 / 0,58

**PP/6135**  
01211350

**cm. 135x 40x 69h**

**1.150,00**  
49.5 / 0,62

**PP/6150**  
01211500

**cm. 150x 40x 69h**

**1.212,00**  
53 / 0,69

**PPS/660**  
01230600

**PENSILE SCOLAPIATTI CON PORTE, GUARNIZIONE E PORTAPIATTI**  
**EN** WALL UNIT PLATE RACK WITH DOORS, GASKETS AND PLATE RACK • **DE** WANDHANGESCHRANK FÜR TELLER MIT FLUGELTUREN UND TURDICHTUNGEN • **FR** ARMOIRE EGOUTTOIR SUSPENDUE AVEC PORTES JOINTS DE PORTE, GRILLE INTERMEDIAIRE PORTE-ASSIETTES • **ES** ARMARIO DE PARED ESCURRIDOR CON PUERTA Y GUARNICION  
**cm. 60x 40x 69h**

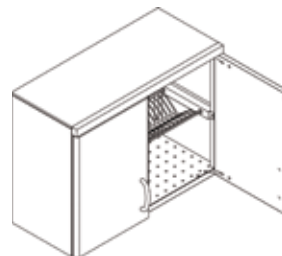

**901,00**  
26 / 0,30

**PPS/690**  
01230900

**cm. 90x 40x 69h**

**987,00**  
34 / 0,43

MOD. \_\_\_\_\_  
COD. \_\_\_\_\_

DESCRIZIONE/DESCRIPTION/BEZEICHNUNG/DESCRIPTION/DESCRIPCIÓN  
DIMENSIONI/DIMENSIONS/ABMESSUNGEN/DIMENSIONS/DIMENSIONES

POTENZA/POWER/LEISTUNG/PUISSANCE/POTENCIA  
VOLTAGGIO/VOLTAGE/SPANNUNG/VOLTAGE/VOLTAJE

⚡ kW kcal/h  
⚡ kw V~ Hz

PREZZO/PRICE €  
PREIS/PRIX/PRECIO €  
KG / M<sup>3</sup>

**PPA/680**  
01260801

**PENSILE AD ANGOLO CON PORTA E RIPIANO INTERMEDIO**

**EN** CORNER WALL UNIT WITH DOOR AND MIDDLE SHELF • **DE** ECK-WANDHANGESCHRANK MIT FLUGELTURE UND ZWISCHENBORD • **FR** ARMOIRE D'ANGLE SUSPENDUE AVEC 2 PORTES ET ETAGERE INTERMEDIAIRE • **ES** ARMARIO ANGULAR DE PARED CON PUERTA Y ESTANTE INTERMEDIO  
**cm.80/80x 40x 69h**

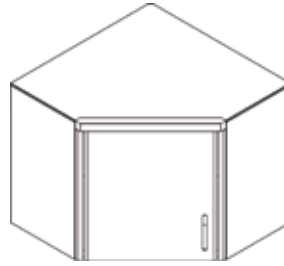

**1.200,00**  
38 / 0,70

**PPV/630SX**  
01220301

**PENSILE CON PORTA VETRO E RIPIANO INTERMEDIO**

**EN** WALL UNIT WITH GLASS DOOR AND MIDDLE SHELF • **DE** WANDHANGESCHRANK MIT GLASTUR UND ZWISCHENBORD • **FR** ARMOIRE SUSPENDUE AVEC PORTE VITREE ET ETAGERE INTERMEDIAIRE • **ES** ARMARIO DE PARED CON PUERTA VIDRIERA Y ESTANTE INTERMEDIO  
**cm. 30x 40x 69h**



**580,00**  
16.5 / 0,17

**PPV/645SX** **cm. 45x 40x 69h**  
01220451

**639,00**  
21 / 0,23

**PPV/630DX** **cm. 30x 40x 69h**  
01220300

**580,00**  
16.5 / 0,17

**PPV/645DX** **cm. 45x 40x 69h**  
01220450

**639,00**  
21 / 0,23

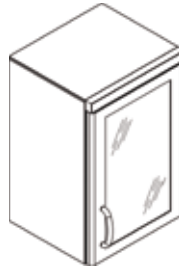

**PPV/660**  
01220600

**PENSILE CON PORTE VETRO, GUARNIZIONE E RIPIANO INTERMEDIO**

**EN** WALL UNIT WITH GLASS DOORS, GASKET AND MIDDLE SHELF • **DE** WANDHANGESCHRANK MIT 2 GLASTURE, TURDICHTUNG UND ZWISCHENBORD • **FR** ARMOIRE SUSPENDUE AVEC 2 PORTES VITREE , JOINT DE PORTE ET ETAGERE INTERMEDIAIRE • **ES** ARMARIO DE PARED CON PUERTAS VIDRIERA, GUARNICION Y ESTANTE INTERMEDIO  
**cm. 60x 40x 69h**

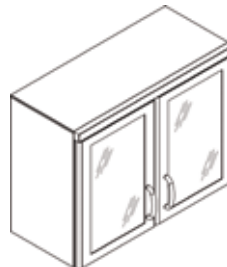

**817,00**  
27 / 0,30

**PPV/690** **cm. 90x 40x 69h**  
01220900

**977,00**  
37 / 0,43

**PPV/6105**  
01221050

**PENSILE CON 3 PORTE VETRO, GUARNIZIONI E RIPIANO INTERMEDIO**

**EN** WALL UNIT WITH 3 GLASS DOORS, GASKETS AND MIDDLE SHELF • **DE** WANDHANGESCHRANK MIT 3 GLASTURE, TURDICHTUNG UND ZWISCHENBORD • **FR** ARMOIRE SUSPENDUE AVEC 3 PORTES VITREE , JOINT DE PORTE ET ETAGERE INTERMEDIAIRE • **ES** ARMARIO DE PARED CON 3 PUERTAS VIDRIERA, GUARNICION Y ESTANTE INTERMEDIO  
**cm. 105x 40x 69h**

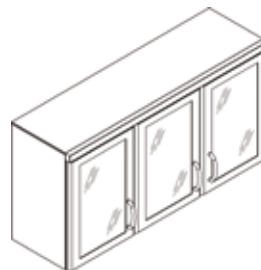

**1.199,00**  
42 / 0,49

**PPV/6135** **cm. 135x 40x 69h**  
01221350

**1.381,00**  
51 / 0,62

MOD. \_\_\_\_\_  
COD. \_\_\_\_\_

DESCRIZIONE/DESCRIPTION/BEZEICHNUNG/DESCRIPTION/DESCRIPCIÓN  
DIMENSIONI/DIMENSIONS/ABMESSUNGEN/DIMENSIONS/DIMENSIONES

POTENZA/POWER/LEISTUNG/PUISSANCE/POTENCIA  
VOLTAGGIO/VOLTAGE/SPANNUNG/VOLTAGE/VOLTAJE

⚡ kW kcal/h  
⚡ kW V~ Hz

PREZZO/PRICE €  
PREIS/PRIX/PRECIO €  
KG / M<sup>3</sup>

**A/660**  
01160600

**ARMADIO CON PORTE, GUARNIZIONI E 4 RIPIANI INTERMEDI**

**EN** TWIN UNIT WITH DOORS, GASKET AND 4 MIDDLE SHELVES • **DE** HOCHSCHRANK MIT TÜREN, TURDICHTUNGEN UND 4 ZWISCHENBORDE • **FR** ARMOIRE A PORTES, JOINTS DE PORTE ET 4 ETAGERES INTERMEDIAIRES • **ES** ARMARIO CON PUERTAS, GUARNICIONES Y 4 ESTANTES INTERMEDIOS  
**cm. 60x 60x 220h**



**1.912,00**  
70 / 1,07

**A/690**  
01160900

**cm. 90x 60x 220h**

**2.294,00**  
99 / 1,52

**AV/660**  
01170600

**ARMADIO CON PORTE VETRO, GUARNIZIONI E 4 RIPIANI INTERMEDI**

**EN** TWIN UNIT WITH GLASS DOORS, GASKETS AND 4 MIDDLE SHELVES • **DE** HOCHSCHRANK MIT 4 GLASTÜREN, TURDICHTUNGEN UND 4 ZWISCHENBORDE • **FR** ARMOIRE AVEC PORTES VITREES, JOINTS DE PORTE ET 4 ETAGERES INTERMEDIAIRES • **ES** ARMARIO CON PUERTAS VIDRIERA, GUARNICIONES Y 4 ESTANTES INTERMEDIOS  
**cm. 60x 60x 220h**

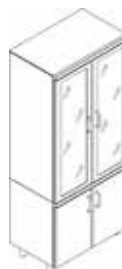

**2.067,00**  
73 / 1,07

**AV/690**  
01170900

**cm. 90x 60x 220h**

**2.454,00**  
102 / 1,52

**KSK/660**  
01280600

**CAPPA STILE CON PARETE E MENSOLA, ASPIRAZIONE AUTOFILTRANTE E CARBONI ATTIVI, 2 VELOCITA' E LUCE**

**EN** SELF-FILTER EXTRACTOR HOOD WITH WALL AND BRACKET, ACTIVATED CHARCOAL, 2 SPEED MOTOR AND LIGHT. • **DE** SELBSTFILTRIERENDE ABZUGSHAUBE MIT KOHLEAKTIVFILTERN, 2-STUFEN GEBLASE, BELEUCHTUNG, WANDVERKLEIDUNG UND KONSOLLE. • **FR** HOTTE D'ASPIRATION DE STYLE AUTOFILTRANTE, AU CHARBON ACTIF, MOTEUR 2 VITESSES, LUMIERE, PAROIR ET ATAGERE • **ES** CAMPANA EXTRACTORA CON PARED Y REPISA, CON ASPIRACION AUTOFILTRANTE Y CARBONES ACTIVOS, 2 VELOCIDADES Y LUZ.  
**cm. 60x 60x 70h**

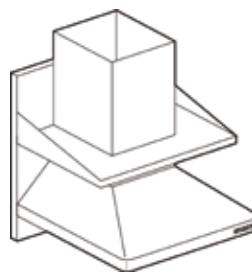

⚡ 0,22 KW **1.087,00**  
230V~ 23 / 0,41  
50 Hz

**KSK/690**  
01280900

**cm. 90x 60x 70h**

⚡ 0,22 KW **1.264,00**  
230V~ 32 / 0,60  
50 Hz

**KSK/6100**  
01281000

**cm. 100x 60x 70h**

⚡ 0,22 KW **1.465,00**  
230V~ 33 / 0,67  
50 Hz

# ACCESSORI

MOD. \_\_\_\_\_  
COD. \_\_\_\_\_

DESCRIZIONE/DESCRIPTION/BEZEICHNUNG/DESCRIPTION/DESCRIPCIÓN  
DIMENSIONI/DIMENSIONS/ABMESSUNGEN/DIMENSIONS/DIMENSIONES

POTENZA/POWER/LEISTUNG/PUISSANCE/POTENCIA  
VOLTAGGIO/VOLTAGE/SPANNUNG/VOLTAGE/VOLTAJE

⚡ kW kcal/h  
⚡ kw V~ Hz

PREZZO/PRICE €  
PREIS/PRIX/PRECIO €  
KG / M<sup>3</sup>

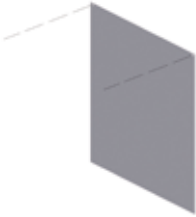
<b>SP/630</b> 01400300	<b>SCHIENA SOTTO PENSILI</b> <b>EN</b> SPLASH BACK FOR WALL UNIT • <b>DE</b> RUCKWAND FÜR HOCHSCHRANK • <b>FR</b> FINITION DOS POUR ARMOIRES SUSPENDUE • <b>ES</b> ESPALDA DEBAJO DE ARMADIO DE PARED <b>cm. 30x 0,2x 62,5h</b>		<b>63,00</b> 1.3 / 0,00
<b>SP/640</b> 01400400	<b>cm. 40x 0,2x 62,5h</b>		<b>83,00</b> 1.8 / 0,01
<b>SP/645</b> 01400450	<b>cm. 45x 0,2x 62,5h</b>		<b>94,00</b> 2 / 0,01
<b>SP/650</b> 01400500	<b>cm. 50x 0,2x 62,5h</b>		<b>104,00</b> 2.2 / 0,01
<b>SP/670</b> 01400700	<b>cm. 70x 0,2x 62,5h</b>		<b>131,00</b> 3.1 / 0,01
<b>SP-SK/680</b> 01400800	<b>cm. 80x 0,2x 80h</b>		<b>150,00</b> 4.5 / 0,01
<b>SP/6105</b> 01401050	<b>cm. 105x 0,2x 62,5h</b>		<b>196,00</b> 4.6 / 0,01
<b>SP/6110</b> 01401100	<b>cm. 110x 0,2x 62,5h</b>		<b>205,00</b> 4.8 / 0,02
<b>SP-SK/6120</b> 01401200	<b>cm. 120x 0,2x 80h</b>		<b>224,00</b> 6.7 / 0,02
<b>SP/6125</b> 01401250	<b>cm. 125x 0,2x 62,5h</b>		<b>233,00</b> 5.5 / 0,02
<b>SP/6135</b> 01401350	<b>cm. 135x 0,2x 62,5h</b>		<b>252,00</b> 5.9 / 0,02
<b>SP-SK/6150</b> 01401500	<b>cm. 150x 0,2x 80h</b>		<b>280,00</b> 8.4 / 0,03
<b>SP-SK/660</b> 01400600	<b>SCHIENA SOTTO PENSILI E CAPPE KSK</b> <b>EN</b> SPLASH BACK FOR WALL UNIT AND HOOD KSK • <b>DE</b> RUCKWAND FÜR HOCHSCHRANK UND HAUBE KSK • <b>FR</b> FINITION DOS POUR ARMOIRES SUSPENDUE ET HOTTE KSK • <b>ES</b> ESPALDA DEBAJO DE ARMADIO DE PARED Y CAMPANA KSK <b>cm. 60x 0,2x 80h</b>		<b>112,00</b> 3.4 / 0,01
<b>SP-SK/690</b> 01400900	<b>cm. 90x 0,2x 80h</b>		<b>168,00</b> 5 / 0,02
<b>SP-SK/6100</b> 01401000	<b>cm. 100x 0,2x 80h</b>		<b>187,00</b> 5.6 / 0,02

FINE KITCHEN

# ACCESSORI

MOD. \_\_\_\_\_  
COD. \_\_\_\_\_

DESCRIZIONE/DESCRIPTION/BEZEICHNUNG/DESCRIPTION/DESCRIPCIÓN  
DIMENSIONI/DIMENSIONS/ABMESSUNGEN/DIMENSIONS/DIMENSIONES

POTENZA/POWER/LEISTUNG/PUISSANCE/POTENCIA  
VOLTAGGIO/VOLTAGE/SPANNUNG/VOLTAGE/VOLTAJE

⚡ kW kcal/h  
⚡ kw V~ Hz

PREZZO/PRICE €  
PREIS/PRIX/PRECIO €  
KG / M<sup>3</sup>

**ZB**  
01410000

**ZOCCOLATURA BASE**  
**EN** FRONT PLINTH • **DE** GRUNDSOCKEL • **FR**  
PLINTHE FRONTAL • **ES** ZOCCOLOS BASE  
€/m x cm. 15h

**113,00**  
/

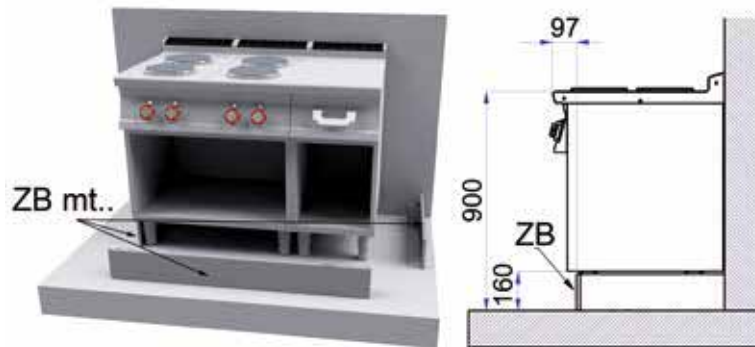

**ZA**  
01410002

**ZOCCOLATURA ANGOLO**  
**EN** CORNER PLINTH • **DE** EKE-SOCKEL • **FR** PLINTHE  
ANGLE • **ES** ZOCCOLOS ANGULAR  
cm. 15h

**69,00**  
0.3 / 0,01

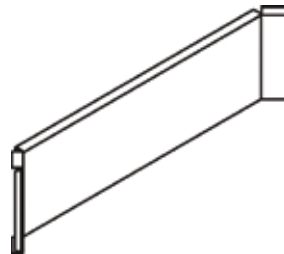

**PC PP/630**  
01430300

**PROTEZIONE CAVO FARETTO**  
**EN** CABLE PROTECTION OF SMALL LAMP • **DE**  
SCHUTZKABEL VOM SCHEINWERFER • **FR**  
PROTECTION CABLE POUR LAMP • **ES** PROTECCION  
CABLE PUNTO DE LUZ  
cm. 30x 1,2x 2,9h

**17,00**  
/ 0,00



**PC PP/640**  
01430400

cm. 40x 1,2x 2,9h

**22,00**  
/ 0,00

**PC PP/645**  
01430450

cm. 45x 1,2x 2,9h

**24,00**  
/ 0,00

**PC PP/650**  
01430500

cm. 50x 1,2x 2,9h

**26,00**  
/ 0,00

**PC PP/660**  
01430600

cm. 60x 1,2x 2,9h

**33,00**  
/ 0,00

**PC PP/670**  
01430700

cm. 70x 1,2x 2,9h

**35,00**  
/ 0,00

**PC PP/680**  
01430800

cm. 80x 1,2x 2,9h

**42,00**  
/ 0,00

**PC PP/690**  
01430900

cm. 90x 1,2x 2,9h

**45,00**  
/ 0,00

**PC PP/6100**  
01431000

cm. 100x 1,2x 2,9h

**48,00**  
/ 0,00

**PC PP/6105**  
01431050

cm. 105x 1,2x 2,9h

**54,00**  
/ 0,00

FINE KITCHEN



Le immagini presentate non sono vincolanti. La ditta si riserva di apportare modifiche senza preavviso. • The pictures are purely representative. The manufacturer reserves the right to modify the technical data and models without previous notice. • Les images

**LO**

présentées ne nous engagent pas. La Société se réserve le droit d'apporter tout modification sans préavis. • Die dargestellten Abbildungen sind nicht verbindlich. Technische Änderungen vorbehalten. • Las imágenes presentadas no son vinculantes. El Fabricante se reserva el derecho de modificar sus productos sin previo aviso.

01/20

**83**



# ACCESSORI

MOD. \_\_\_\_\_  
COD. \_\_\_\_\_

DESCRIZIONE/DESCRIPTION/BEZEICHNUNG/DESCRIPTION/DESCRIPCIÓN  
DIMENSIONI/DIMENSIONS/ABMESSUNGEN/DIMENSIONS/DIMENSIONES

POTENZA/POWER/LEISTUNG/PUISSANCE/POTENCIA  
VOLTAGGIO/VOLTAGE/SPANNUNG/VOLTAGE/VOLTAJE

⚡ kW kcal/h  
⚡ kW V~ Hz

PREZZO/PRICE €  
PREIS/PRIX/PRECIO €  
KG / M<sup>3</sup>

**PC PP/6110 cm. 110x 1,2x 2,9h**  
01431100

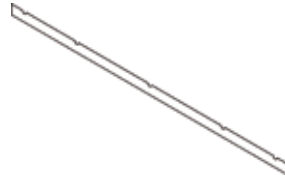

**57,00**  
/ 0,00

**PC PP/6120 cm. 120x 1,2x 2,9h**  
01431200

**67,00**  
/ 0,00

**PC PP/6125 cm. 125x 1,2x 2,9h**  
01431250

**71,00**  
/ 0,00

**PC PP/6135 cm. 135x 1,2x 2,9h**  
01431350

**78,00**  
/ 0,00

**PC PP/6150 cm. 150x 1,2x 2,9h**  
01431500

**85,00**  
/ 0,00

**KIT FARETTO KIT FARETTO LED 1,3W L2000**  
**(FARETTO, GHIERA, STAFFA)**  
01420000  
**EN** KIT SMALL LAMP LED 1,3W L2000 • **DE** KIT SCHEINWERFER LED 1,3W L2000 • **FR** KIT LAMPE LED 1,3W L2000 • **ES** PUNTO DE LUZ LED 1,3W L2000

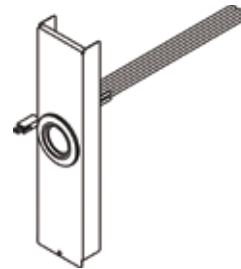

⚡ 0,001 KW  
12V~  
50/60 Hz  
**126,00**  
/ 0,00

**TRASFORMATORE TRASFORMATORE 230V-12V MAX 6 INGRESSI**  
01420001  
**LED**  
**EN** TRANSFORMER 230V-12V MAX 6 LED • **DE** VERWANDLER 230V-12V MAX 6 LED • **FR** TRANSFORMATEUR 230V-12V MAX 6 LED • **ES** TRANSFORMADOR DE CORRIENTE 230V-12V MAX 6 LED

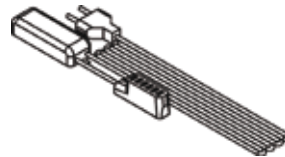

**69,00**  
/ 0,00

**PROLUNGA BT PROLUNGA 12V L1500**  
01420002  
**EN** EXTENSION 12V-L1500 • **DE** FORTSATZT 12V L1500 • **FR** RALLONGE 12V L1500 • **ES** EXTENSIÓN 12V L1500



**38,00**  
/ 1,00

**EROS4 GRUPPO RUBINETTO DOCCIA A LEVA**  
\_EROS004  
**EN** TAP FOR SINK WITH SHOWER • **DE** MISCHBATTERIE • **FR** GROUPE ROBINET AVEC DOUCHE • **ES** GRUPO GRIFO CON DUCHA  
**cm. 27x 45h**



**270,00**  
2 / 0,01

**GL GRUPPO RUBINETTO A LEVA, A NORME**  
51262000  
**IGENICHE**  
**EN** LEVER TAP FOR SINK IN ACCORDANCE WITH SANITARY REGULATIONS • **DE** EINHEBEL-MISCHBATTERIE • **FR** GROUPE ROBINET A LEVIER, AUX NORMES HYGIENIQUES • **ES** GRUPO GRIFO CON PALANCA SEGUN NORMAS HIGIENICAS  
**cm. 21x 24h**



**152,00**  
1 / 0,00

# ACCESSORI

MOD. \_\_\_\_\_  
COD. \_\_\_\_\_

DESCRIZIONE/DESCRIPTION/BEZEICHNUNG/DESCRIPTION/DESCRIPCIÓN  
DIMENSIONI/DIMENSIONS/ABMESSUNGEN/DIMENSIONS/DIMENSIONES

POTENZA/POWER/LEISTUNG/PUISSANCE/POTENCIA  
VOLTAGGIO/VOLTAGE/SPANNUNG/VOLTAGE/VOLTAJE

$\frac{kW}{kcal/h}$   $\frac{V}{Hz}$

PREZZO/PRICE €  
PREIS/PRIX/PRECIO €  
KG / M<sup>3</sup>

SER  
01.440000

**KIT SERRATURA CON CHIAVE PER PORTA**  
**EN KIT LOCK WITH KEYS FOR DOOR • DE KIT**  
**SCHLOSS KT SCHLUSSEL FUR TUR • FR SERRURE**  
**AVEC CLES POUR PORTE • ES CERRADURA CON**  
**LLAVE PARA PUERTA**



**48,00**  
/





65

# BAGNOMARIA ELETTRICI

MOD. \_\_\_\_\_  
COD. \_\_\_\_\_

DESCRIZIONE/DESCRIPTION/BEZEICHNUNG/DESCRIPTION/DESCRIPCIÓN  
DIMENSIONI/DIMENSIONS/ABMESSUNGEN/DIMENSIONS/DIMENSIONES

POTENZA/POWER/LEISTUNG/PUISSANCE/POTENCIA  
VOLTAGGIO/VOLTAGE/SPANNUNG/VOLTAGE/VOLTAJE

⚡ kW kcal/h  
⚡ kW V~ Hz

PREZZO/PRICE €  
PREIS/PRIX/PRECIO €  
KG / M<sup>3</sup>

**BM-4EM**  
07050410

**BAGNOMARIA MONOFASE VASCA PER GN 1/1 H.15**

EN Bain marie singlephase - Bowl for GN 1/1 h.15  
• DE Wasserbäder einphasig - Becken GN 1/1 h.15  
• FR Bain marie monophasé - Cuve GN 1/1 h.15 • ES Baño de maría monofásico - Cuba para GN 1/1 15h  
**cm. 40x 65x 29h**



⚡ 2,1 kW **854,00**  
230V~ 21 / 0,18  
50/60 Hz

**BM-6EM**  
07050610

**BAGNOMARIA MONOFASE VASCA PER 1 GN 1/1 + 2 GN 1/4 H.15**

EN Bain marie singlephase - Bowl for 1 GN 1/1 + 2 GN 1/4 h.15 • DE Wasserbäder einphasig - Becken für 1 GN 1/1 + 2 GN 1/4 h.15 • FR Bain-marie monophasé - Cuve pour 1 GN 1/1 + 2 GN 1/4 h.15  
• ES Baño de maría monofásico - Cuba para 1 GN 1/1 + 2 GN 1/4 15h  
**cm. 60x 65x 29h**

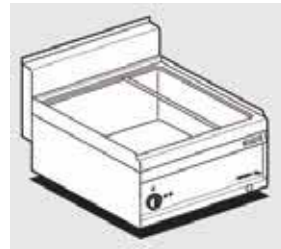

⚡ 3,15 kW **1.037,00**  
230V~ 27 / 0,27  
50/60 Hz

**BM-8ET**  
07050830

**BAGNOMARIA TRIFASE VASCA PER 2 GN 1/1 H.15**

EN Bain marie threephase - Bowl for 2 GN 1/1 h.15  
• DE Wasserbäder dreiphasig - Becken für 2 GN 1/1 h.15 • FR Bain-marie triphasé - Cuve pour 2 GN 1/1 h.15 • ES Baño de maría trifásico - Cuba para 2 GN 1/1 15h  
**cm. 80x 65x 29h**



⚡ 4,2 kW **1.355,00**  
400V~3N 31 / 0,35  
230V~3  
50/60 Hz

**BM-10ET**  
07051030

**BAGNOMARIA TRIFASE VASCA PER 3 GN 1/1 H.15**

EN Bain marie threephase - Bowl for 3 GN 1/1 h.15  
• DE Wasserbäder dreiphasig - Becken für 3 GN 1/1 h.15 • FR Bain-marie triphasé - Cuve pour 3 GN 1/1 h.15 • ES Baño de maría trifásico - Cuba para 3 GN 1/1 15h  
**cm. 100x 65x 29h**

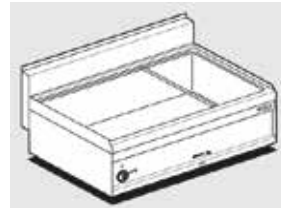

⚡ 6,3 kW **1.575,00**  
400V~3N 36.5 / 0,43  
230V~3  
50/60 Hz

**BM-4G**  
07220450

**BAGNOMARIA GAS - VASCA PER GN 1/1 H.15**

EN Gas bain-marie - Bowl for GN 1/1 h.15 • DE Gas Wasserbad - Becken für GN 1/1 h.15 • FR Bain-marie gaz - Cuve pour GN 1/1 h.15 • ES Baño de maría gas - Cuba para GN 1/1 h.15  
**cm. 40x 65x 29h**



⚡ 3,5 kW **1.193,00**  
3.010 kcal/h 27 / 0,18

**BM-6G**  
07220650

**BAGNOMARIA GAS VASCA PER GN 1/1 + 2 GN 1/4, H.15**

EN Gas bain-marie - Bowl for GN 1/1 + 2 GN 1/4, h.15 • DE Gas Wasserbad - Becken für GN 1/1 + 2 GN 1/4, h.15 • FR Bain-marie gaz - Cuve pour GN 1/1 + 2 GN 1/4, h.15 • ES Baño de maría gas - Cuba para GN 1/1 + 2 GN 1/4, h.15  
**cm. 60x 65x 29h**



⚡ 5 kW **1.541,00**  
4.300 kcal/h 33 / 0,27



# BAGNOMARIA A GAS

MOD. \_\_\_\_\_  
COD. \_\_\_\_\_

DESCRIZIONE/DESCRIPTION/BEZEICHNUNG/DESCRIPTION/DESCRIPCIÓN  
DIMENSIONI/DIMENSIONS/ABMESSUNGEN/DIMENSIONS/DIMENSIONES

POTENZA/POWER/LEISTUNG/PUISSANCE/POTENCIA  
VOLTAGGIO/VOLTAGE/SPANNUNG/VOLTAGE/VOLTAJE

⚡ kW kcal/h  
⚡ kw kcal/h  
V~ Hz

PREZZO/PRICE €  
PREIS/PRIX/PRECIO €  
KG / M<sup>3</sup>

**BM-8G**  
07220850

**BAGNOMARIA GAS - VASCA PER 2 GN 1/1, H.15**

**EN** Gas bain-marie - Bowl for 2 GN 1/1, h.15 • **DE** Gas Wasserbad - Becken für 2 GN 1/1, h.15 • **FR** Bain-marie gaz - Cuve pour 2 GN 1/1, h.15 • **ES** Baño de maría gas - Cuba para 2 GN 1/1, h.15  
**cm. 80x 65x 29h**

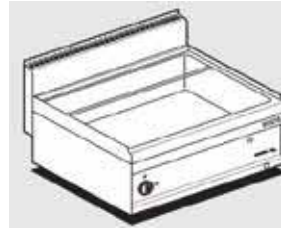

⚡ 6,5 kW 1.957,00  
5.590 kcal/h 39 / 0,35

**BS-4EM**  
07040410

**CONTENITORE CALDO MONOFASE VASCA CM. 30,5X51X16,5H CON FALSO FONDO FORATO.**

**EN** Fry dump singlephase Bowl cm. 30,5x51x16,5h with perforated bottom. • **DE** Frittenwanne einphasig Becke cm. 30,5x51x16,5h mit gelochtem Bodenrost. • **FR** Silo à frites monophasé Cuve cm 30,5x51x16,5h avec double-fond perforé • **ES** Recipiente caliente monofásico Cuba cm. 30,5x51x16,5h con falso fondo agujereado  
**cm. 40x 65x 29h**



⚡ 0,82 kW 864,00  
230V~ 21.5 / 0,18  
50/60 Hz

**RI-4EM**  
07040411

**RISCALDANTE INFRAROSSO MONOFASE**

**EN** Infra-red heater singlephase • **DE** Infrarot-Strahler einphasig • **FR** Lampe chauffante à infrarouge monophasé • **ES** Calentador infrarrojo monofásico  
**cm. 39x 50x 37h**



⚡ 0,33 kW 636,00  
230V~ 8 / 0,10  
50/60 Hz

**PC-4ET**  
07030430

**PIANO COTTURA TRIFASE N. 2 PIASTRE**

**EN** Boiling unit - N. 2 plates • **DE** Kochplatte - N. 2 Kochplatten • **FR** Rechaud - N. 2 plaques • **ES** Sobre de cocción - N. 2 planchas  
**cm. 40x 65x 29h**



⚡ 4 kW 708,00  
400V~2N 25.5 / 0,18  
230V~3  
230V~  
50/60 Hz

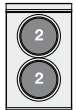

**PC-6ET**  
07030630

**PIANO COTTURA TRIFASE N. 4 PIASTRE**

**EN** Boiling unit - N. 4 plates • **DE** Kochplatte - N. 4 Kochplatten • **FR** Rechaud - N. 4 plaques • **ES** Sobre de cocción - N. 4 planchas  
**cm. 60x 65x 29h**



⚡ 7,5 kW 1.270,00  
400V~3N 37 / 0,27  
230V~3  
230V~  
50/60 Hz

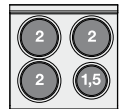

**PC-8ET**  
07030830

**cm. 80x 65x 29h**

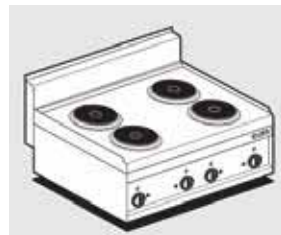

⚡ 8 kW 1.441,00  
400V~3N 43.5 / 0,35  
230V~3  
50/60 Hz

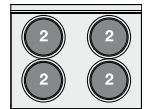

65



Le immagini presentate non sono vincolanti. La ditta si riserva di apportare modifiche senza preavviso. • The pictures are purely representative. The manufacturer reserves the right to modify the technical data and models without previous notice. • Les images

LO

présentées ne nous engagent pas. La Société se réserve le droit d'apporter tout modification sans préavis. • Die dargestellten Abbildungen sind nicht verbindlich. Technische Änderungen vorbehalten. • Las imágenes presentadas no son vinculantes. El Fabricante se reserva el derecho de modificar sus productos sin previo aviso.

01/20

89

# PIANI COTTURA ELETTRICI

MOD. \_\_\_\_\_  
COD. \_\_\_\_\_

DESCRIZIONE/DESCRIPTION/BEZEICHNUNG/DESCRIPTION/DESCRIPCIÓN  
DIMENSIONI/DIMENSIONS/ABMESSUNGEN/DIMENSIONS/DIMENSIONES

POTENZA/POWER/LEISTUNG/PUISSANCE/POTENCIA  
VOLTAGGIO/VOLTAGE/SPANNUNG/VOLTAGE/VOLTAJE

⚡ kcal/h  
kw  
V~  
Hz

PREZZO/PRICE €  
PREIS/PRIX/PRECIO  
KG / M<sup>3</sup>

**PC-10ET**  
07031030

**PIANO COTTURA TRIFASE N. 6 PIASTRE**  
**EN** Boiling unit three-phase - N. 6 plates • **DE** Kochplatte dreiphasig - N. 6 Kochplatten • **FR** Rechaud triphase - N. 6 plaques • **ES** Sobre de cocción trifásico - 6 planchas  
**cm. 100x 65x 29h**



⚡ 11,5 kW  
400V~3N  
230V~3  
50/60 Hz

**1.845,00**  
53.5 / 0,43

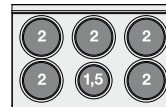

**PCIW-4ET**  
07030434

**PIANO COTTURA INDUZIONE TRIFASE "WOK"**  
**- N. 1 ZONA - VETRO Ø 30 CM.**  
**EN** Three-phase induction cooking "WOK" - 1 zone - glass Ø 30 cm • **DE** Induktions-Kochplatte "WOK" dreiphasig - 1 zonen - Glas Ø 30 cm • **FR** Plan de cuisson à induction "WOK" triphasé N. 1 zone - Verre cm Ø 30 • **ES** Encimera inducción "WOK" trifásica - 1 zona - Vidrio Ø 30 cm  
**cm. 40x 65x 29h**



⚡ 5 kW  
400V~3  
50/60 Hz

**4.526,00**  
24 / 0,18

**PCIW-4ETD**  
07030439

**PIANO COTTURA INDUZIONE TRIFASE "WOK"**  
**- N. 1 ZONA - VETRO Ø 30 CM. - COMANDI DIGITALI**  
**EN** Three-phase induction cooking "WOK" - 1 zone - glass Ø 30 cm - digital controls • **DE** Induktions-Kochplatte "WOK" dreiphasig - 1 zonen - Glas Ø 30 cm - digitale Steuerungen • **FR** Plan de cuisson à induction "WOK" triphasé N. 1 zone - Verre cm Ø 30 - commandes numériques • **ES** Encimera inducción "WOK" trifásica - 1 zona - Vidrio Ø 30 cm - controles digitales  
**cm. 40x 65x 29h**



⚡ 5 kW  
400V~3  
50/60 Hz

**4.774,00**  
24 / 0,18

**PC-4G**  
07210450

**PIANO COTTURA GAS 2 FUOCHI**  
**EN** Gas heated boiling unit - 2 burners • **DE** Gas-Kochplatte - 2 Kochstellen • **FR** Rechaud gaz - 2 Feux vifs • **ES** Sobres de cocción gas - 2 quemadores  
**cm. 40x 65x 29h**



⚡ 9 kW  
7.740 kcal/h

**980,00**  
44 / 0,18

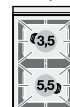

**PC-8G**  
07210850

**PIANO COTTURA GAS 4 FUOCHI**  
**EN** Gas heated boiling unit - 4 burners • **DE** Gas-Kochplatte - 4 Kochstellen • **FR** Rechaud gaz - 4 Feux vifs • **ES** Sobres de cocción gas - 4 quemadores  
**cm. 80x 65x 29h**



⚡ 18 kW  
15.480 kcal/h

**1.504,00**  
60.5 / 0,35

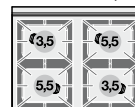

**PC-12G**  
07211250

**PIANO COTTURA GAS 6 FUOCHI**  
**EN** Gas heated boiling unit - 6 burners • **DE** Gas-Kochplatte - 6 Kochstellen • **FR** Rechaud gaz - 6 Feux vifs • **ES** Sobres de cocción gas - 6 quemadores  
**cm. 120x 65x 29h**



⚡ 27 kW  
23.220 kcal/h

**2.335,00**  
101 / 0,52

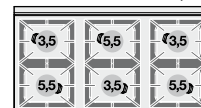

01/20  
**90**

Le immagini presentate non sono vincolanti. La ditta si riserva di apportare modifiche senza preavviso. • The pictures are purely representative. The manufacturer reserves the right to modify the technical data and models without previous notice. • Les images présentées ne nous engagent pas. La Société se réserve le

**LO**

droit d'apporter tout modification sans préavis. • Die dargestellten Abbildungen sind nicht verbindlich. Technische Änderungen vorbehalten. • Las imágenes presentadas no son vinculantes. El Fabricante se reserva el derecho de modificar sus productos sin previo aviso.



# PIANI COTTURA ELETTRICI

MOD. \_\_\_\_\_  
COD. \_\_\_\_\_

DESCRIZIONE/DESCRIPTION/BEZEICHNUNG/DESCRIPTION/DESCRIPCIÓN  
DIMENSIONI/DIMENSIONS/ABMESSUNGEN/DIMENSIONS/DIMENSIONES

POTENZA/POWER/LEISTUNG/PUISSANCE/POTENCIA  
VOLTAGGIO/VOLTAGE/SPANNUNG/VOLTAGE/VOLTAJE

⚡ kW \_\_\_\_\_  
kcal/h \_\_\_\_\_  
V~ \_\_\_\_\_  
Hz \_\_\_\_\_

PREZZO/PRICE € \_\_\_\_\_  
PREIS/PRIX/PRECIO € \_\_\_\_\_  
KG / M<sup>3</sup> \_\_\_\_\_

**PCC-4ET**  
07110430

**PIANO COTTURA VETROCERAMICA TRIFASE 2  
PIASTRE - VETRO: CM. 36X52**

**EN** Boiling unit ceramic glass threephase, 2 plates.  
Glass: cm. 36x52 • **DE** Kochplatte ceran-kochfläche  
dreiphasig, 2 Kochplatten. Kochfläche: cm. 36x52 • **FR**  
Rechaud triphase vitrocéramique, 2 foyers. Vitre: cm.  
36x52 • **ES** Sobres de cocción vitrocerámica trifásico, 2  
planchas. Vidrio: 36x52 cm  
**cm. 40x 65x 29h**



⚡ 3,6 kW \_\_\_\_\_ **1.609,00**  
400V~2N \_\_\_\_\_ 23.5 / 0,18  
230V~3  
230V~  
50/60 Hz

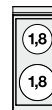

**PCC-6ET**  
07110630

**PIANO COTTURA VETROCERAMICA TRIFASE 4  
PIASTRE - VETRO: CM. 56X52**

**EN** Boiling unit ceramic glass threephase, 4 plates.  
Glass: cm. 56x52 • **DE** Kochplatte Ceran-Kochfläche  
dreiphasig, 4 Kochplatten. Kochfläche: cm. 56x52 • **FR**  
Rechaud triphase vitrocéramique, 4 foyers. Vitre: cm.  
56x52 • **ES** Sobres de cocción vitrocerámica trifásico, 4  
planchas. Vidrio: 56x52 cm  
**cm. 60x 65x 29h**



⚡ 7,2 kW \_\_\_\_\_ **2.430,00**  
400V~3N \_\_\_\_\_ 32 / 0,27  
230V~3  
230V~  
50/60 Hz

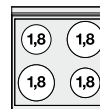

**PCC-8ET**  
07110830

**PIANO COTTURA VETROCERAMICA TRIFASE 4  
PIASTRE - VETRO: CM. 76X52**

**EN** Boiling unit ceramic glass threephase, 4 plates.  
Glass: cm. 76x52 • **DE** Kochplatte Ceran-Kochfläche  
dreiphasig, 4 Kochplatten. Kochfläche: cm. 76x52 • **FR**  
Rechaud triphase vitrocéramique, 4 foyers. Vitre: cm.  
76x52 • **ES** Sobres de cocción vitrocerámica trifásico, 4  
planchas. Vidrio: 76x52 cm  
**cm. 80x 65x 29h**

⚡ 8,6 kW \_\_\_\_\_ **2.936,00**  
400V~3N \_\_\_\_\_ 37 / 0,35  
230V~3  
50/60 Hz

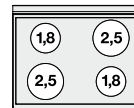

**BR-6ET**  
07070630

**BRASIERA TRIFASE - LT. 20 - VASCA CM.  
50,5X41X10H**

**EN** Bratt-pan threephase - Cap. 20 litres - Pan cm.  
50,5x41x10h • **DE** Bratpfanne dreiphasig lt. 20 -  
Becken cm. 50,5x41x10h • **FR** Sauteuse triphase  
capacité 20 lt. Cuve cm. 50,5x41x10h • **ES** Sartén  
trifásica 20 lt. - Cuba cm. 50,5x41x10h  
**cm. 60x 65x 29h**



⚡ 6 kW \_\_\_\_\_ **1.559,00**  
400V~3N \_\_\_\_\_ 47 / 0,27  
230V~3  
50/60 Hz

**BR-6G**  
07240650

**BRASIERA GAS LT. 20 - VASCA CM.  
50,5X41X10H**

**EN** Gas bratt-pan - Capacity 20 litres - Pan cm.  
50,5x41x10 h • **DE** Gas Bratpfanne - lt. 20 - Becken  
cm. 50,5x41x10 h • **FR** Sauteuse gaz - lt. 20 - Bac  
cm. 50,5x41x10h • **ES** Sartén gas - 20 l. - Cuba cm.  
50,5x41x10h  
**cm. 60x 65x 29h**



⚡ 6,9 kW \_\_\_\_\_ **2.026,00**  
5.930 kcal/h \_\_\_\_\_ 46 / 0,27



Le immagini presentate non sono vincolanti. La ditta si riserva di apportare modifiche senza preavviso. • The pictures are purely representative. The manufacturer reserves the right to modify the technical data and models without previous notice. • Les images

LO

présentées ne nous engagent pas. La Société se réserve le droit d'apporter tout modification sans préavis. • Die dargestellten Abbildungen sind nicht verbindlich. Technische Änderungen vorbehalten. • Las imágenes presentadas no son vinculantes. El Fabricante se reserva el derecho de modificar sus productos sin previo aviso.

01/20

91

65

MOD. \_\_\_\_\_  
COD. \_\_\_\_\_

DESCRIZIONE/DESCRIPTION/BEZEICHNUNG/DESCRIPTION/DESCRIPCIÓN  
DIMENSIONI/DIMENSIONS/ABMESSUNGEN/DIMENSIONS/DIMENSIONES

POTENZA/POWER/LEISTUNG/PUISSANCE/POTENCIA  
VOLTAGGIO/VOLTAGE/SPANNUNG/VOLTAGE/VOLTAJE

⚡ kW kcal/h  
V~ Hz

PREZZO/PRICE €  
PREIS/PRIX/PRECIO €  
KG / M<sup>3</sup>

**CF4-8ET**  
07660830

**CUCINA ELETTRICA CON 4 PIASTRE FORNO ELETTRICO MULTIFUNZIONE CAMERA CM. 64X37X35H, TEMP: 50÷250°C, CON 1 GRIGLIA CM.53X32,5 GN1/1 - PORTA VETRO**  
EN Range N. 4 plates Multifunction electric oven Chamber cm. 64x37x35h, temp: 50÷250°C ,with 1 grid cm.53x32,5 GN1/1 - Glass door • **DE** Elektroherd N. 4 Kochplatten Multifunktions-Elektroofen cm. 64x37x35h, temp: 50÷250°C ,with 1 grid GN1/1 - Glastür • **FR** Cuisinière - N. 4 plaques Four électrique à fonctions multiples cm. 64x37x35h, temp: 50÷250°C ,avec 1 grille cm.53x32,5 GN1/1 - Porte vitrée • **ES** Cocina N. 4 planchas Horno eléctrico multifuncional - Cámara cm. 64x37x35h, temp: 50÷250°C ,con 1 parilla cm.53x32,5 GN1/1 - Puerta vidrio  
**cm. 80x 65x 87h**



⚡ 11,11 kW 2.923,00  
400V~3N 95 / 0,78  
230V~3  
50/60 Hz

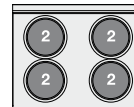

**CF4-8ET**  
07660831

**CUCINA ELETTRICA CON 4 PIASTRE FORNO ELETTRICO MULTIFUNZIONE CAMERA CM. 64X37X35H, TEMP: 50÷250°C, CON 1 GRIGLIA CM.53X32,5 GN1/1 - PORTA CIECA INOX**  
EN Range N. 4 plates Multifunction electric oven Chamber cm. 64x37x35h, temp: 50÷250°C ,with 1 grid cm.53x32,5 GN1/1 - Stainless steel door • **DE** Elektroherd N. 4 Kochplatten Multifunktions-Elektroofen cm. 64x37x35h, temp: 50÷250°C ,with 1 grid cm.53x32,5 GN1/1 - Edelstahltür • **FR** Cuisinière - N. 4 plaques Four électrique à fonctions multiples cm. 64x37x35h, temp: 50÷250°C ,avec 1 grille cm.53x32,5 GN1/1 - Porte acier inoxydable • **ES** Cocina N. 4 planchas Horno eléctrico multifuncional - Cámara cm. 64x37x35h, temp: 50÷250°C ,con 1 parilla cm.53x32,5 GN1/1 - Puerta ciega inox  
**cm. 80x 65x 87h**



⚡ 11,11 kW 2.923,00  
400V~3N 95 / 0,78  
230V~3  
50/60 Hz

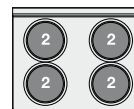

**CF4-8ETS**  
07660832

**CUCINA ELETTRICA CON N. 4 PIASTRE - FORNO ELETTRICO STATICO C/GRILL CM. 64X42X35H, TEMP: 50÷250°C, CON 1 GRIGLIA CM.53X32,5 GN1/1 - PORTA VETRO**  
EN Range N. 4 plates - Static oven with grill cm. 64x42x35h, temp: 50÷250°C ,with 1 grid cm.53x32,5 GN1/1 - Glass door • **DE** Elektroherd N. 4 Kochplatten Statischer Ofen mit Grill cm. 64x42x35h, temp: 50÷250°C ,with 1 grid cm.53x32,5 GN1/1 - Glastür • **FR** Cuisinière N. 4 plaques - Four statique avec grill cm. 64x42x35h, temp: 50÷250°C ,mit 1 Rost cm.53x32,5 GN1/1 - Porte vitrée • **ES** Cocina N. 4 planchas - Horno estático con asador cm. 64x42x35h, temp: 50÷250°C ,con 1 parilla cm.53x32,5 GN1/1 - Puerta vidrio  
**cm. 80x 65x 87h**



⚡ 10,62 kW 2.558,00  
400V~3N 95 / 0,78  
230V~3  
50/60 Hz

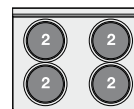

**CF4-8ETS**  
07660833

**CUCINA ELETTRICA CON N. 4 PIASTRE - FORNO ELETTRICO STATICO C/GRILL CM. 64X42X35H, TEMP: 50÷250°C, CON 1 GRIGLIA CM.53X32,5 GN1/1 - PORTA CIECA INOX**  
EN Range N. 4 plates - Static oven with grill cm. 64x42x35h, temp: 50÷250°C ,with 1 grid cm.53x32,5 GN1/1 - Stainless steel door • **DE** Elektroherd N. 4 Kochplatten Statischer Ofen mit Grill cm. 64x42x35h, temp: 50÷250°C ,with 1 grid cm.53x32,5 GN1/1 - Edelstahltür • **FR** Cuisinière N. 4 plaques - Four statique avec grill cm. 64x42x35h, temp: 50÷250°C ,mit 1 Rost cm.53x32,5 GN1/1 - Porte acier inoxydable • **ES** Cocina N. 4 planchas - Horno estático con asador cm. 64x42x35h, temp: 50÷250°C ,con 1 parilla cm.53x32,5 GN1/1 - Puerta ciega inox  
**cm. 80x 65x 87h**



⚡ 10,62 kW 2.558,00  
400V~3N 95 / 0,78  
230V~3  
50/60 Hz

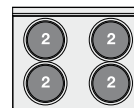



MOD. \_\_\_\_\_  
COD. \_\_\_\_\_

DESCRIZIONE/DESCRIPTION/BEZEICHNUNG/DESCRIPTION/DESCRIPCIÓN  
DIMENSIONI/DIMENSIONS/ABMESSUNGEN/DIMENSIONS/DIMENSIONES

POTENZA/POWER/LEISTUNG/PUISSANCE/POTENCIA  
VOLTAGGIO/VOLTAGE/SPANNUNG/VOLTAGE/VOLTAJE

⚡ kW \_\_\_\_\_  
kcal/h \_\_\_\_\_  
V~ \_\_\_\_\_  
Hz \_\_\_\_\_

PREZZO/PRICE € \_\_\_\_\_  
PREIS/PRIX/PRECIO € \_\_\_\_\_  
KG / M<sup>3</sup> \_\_\_\_\_

**CF4-8ET**  
07670830

**CUCINA CON PIANO IN VETROCERAMICA  
VETRO CM. 76X52 FORNO MULTIFUNZIONE -  
CAMERA CM. 64X37X35H, TEMP: 50÷250°C,  
CON 1 GRIGLIA CM.53X32,5 GN1/1 - PORTA  
VETRO**

**EN** Range - Ceramic, Glass: cm. 76x52 Multifunction oven - Chamber cm. 64x37x35h, temp: 50÷250°C ,with 1 grid cm.53x32,5 GN1/1 - Glass door  
• **DE** Elektroherd - Ceran-Kochfläche cm. 76x52 Multifunktions-Ofen cm. 64x37x35h, temp: 50÷250°C ,with 1 grid cm.53x32,5 GN1/1 - Glastür • **FR** Cuisinière - Vitrocéramique Plaque cm. 76x52 Four à fonctions multiples cm. 64x37x35h, temp: 50÷250°C ,avec 1 grille cm.53x32,5 GN1/1 - Porte vitrée • **ES** Cocina - Placa vitrocerámica, cristal cm. 76x52 Horno multifuncional - Cámara cm. 64x37x35h, temp: 50÷250°C ,con 1 parilla cm.53x32,5 GN1/1 - Puerta vidrio

**cm. 80x 65x 87h**



⚡ 11,71 kW \_\_\_\_\_ **4.664,00**  
400V~3N \_\_\_\_\_ 95 / 0,78  
230V~3 \_\_\_\_\_  
50/60 Hz \_\_\_\_\_

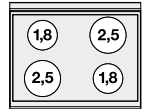

**CF4-8ET**  
07670831

**CUCINA CON PIANO IN VETROCERAMICA  
VETRO CM. 76X52 FORNO MULTIFUNZIONE -  
CAMERA CM. 64X37X35H, TEMP: 50÷250°C,  
CON 1 GRIGLIA CM.53X32,5 GN1/1 - PORTA  
CIECA INOX**

**EN** Range - Ceramic, Glass: cm. 76x52 Multifunction oven - Chamber cm. 64x37x35h, temp: 50÷250°C ,with 1 grid cm.53x32,5 GN1/1 - Stainless steel door  
• **DE** Elektroherd - Ceran-Kochfläche cm. 76x52 Multifunktions-Ofen cm. 64x37x35h, temp: 50÷250°C ,with 1 grid cm.53x32,5 GN1/1 - Edelstahltür  
• **FR** Cuisinière - Vitrocéramique Plaque cm. 76x52 Four à fonctions multiples cm. 64x37x35h, temp: 50÷250°C ,avec 1 grille cm.53x32,5 GN1/1 - Porte acier inoxydable • **ES** Cocina - Placa vitrocerámica, cristal cm. 76x52 Horno multifuncional - Cámara cm. 64x37x35h, temp: 50÷250°C ,con 1 parilla cm.53x32,5 GN1/1 - Puerta ciega inox

**cm. 80x 65x 87h**

⚡ 11,71 kW \_\_\_\_\_ **4.664,00**  
400V~3N \_\_\_\_\_ 95 / 0,78  
230V~3 \_\_\_\_\_  
50/60 Hz \_\_\_\_\_

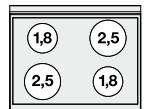

**CF4-8G**  
07680850

**CUCINA A GAS 4 FUOCHI FORNO A GAS  
STATICO CON GRILL CM. 64X39X35H, TEMP:  
125÷275°C, CON 1 GRIGLIA CM.53X32,5  
GN1/1 - PORTA VETRO**

**EN** Gas range - N. 4 burners - Gas static oven with grill cm. 64x39x35h, temp: 125÷275°C, with 1 grid cm.53x32,5 GN1/1 - glass door • **DE** Gasherd - N. 4 Kochstellen - Gas Statischer Backofen mit grill cm. 64x39x35h, temp: 125÷275°C, mit 1 Rost cm.53x32,5 GN1/1 - Glastür • **FR** Cuisinière gaz - N. 4 feux vifs - Four gaz statique avec grill cm. 64x39x35h, temp: 125÷275°C, avec 1 grille cm.53x32,5 GN1/1 - Porte vitrée • **ES** Cocina gas - N. 4 quemadores - Horno gas estático con asador cm. 64x39x35h, temp: 125÷275°C, con 1 parilla cm.53x32,5 GN1/1 - Puerta vidrio

**cm. 80x 65x 87h**



⚡ 22 kW \_\_\_\_\_ **3.446,00**  
18.920 kcal/h \_\_\_\_\_ 97 / 0,78

⚡ 0,03 kW \_\_\_\_\_  
230V~ \_\_\_\_\_  
50/60 Hz \_\_\_\_\_

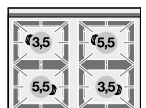

**CF4-8G**  
07680851

**CUCINA A GAS 4 FUOCHI FORNO A GAS  
STATICO CON GRILL CM. 64X39X35H, TEMP:  
125÷275°C, CON 1 GRIGLIA CM.53X32,5  
GN1/1 - PORTA CIECA INOX**

**EN** Gas range - N. 4 burners - Gas static oven with grill cm. 64x39x35h, temp: 125÷275°C, with 1 grid cm.53x32,5 GN1/1 - Stainless steel door • **DE** Gasherd - N. 4 Kochstellen - Gas Statischer Backofen mit grill cm. 64x39x35h, temp: 125÷275°C, mit 1 Rost cm.53x32,5 GN1/1 - Edelstahltür • **FR** Cuisinière gaz - N. 4 feux vifs - Four gaz statique avec grill cm. 64x39x35h, temp: 125÷275°C, avec 1 grille cm.53x32,5 GN1/1 - Porte acier inoxydable • **ES** Cocina gas - N. 4 quemadores - Horno gas estático con asador cm. 64x39x35h, temp: 125÷275°C, con 1 parilla cm.53x32,5 GN1/1 - Puerta ciega inox

**cm. 80x 65x 87h**



⚡ 22 kW \_\_\_\_\_ **3.446,00**  
18.920 kcal/h \_\_\_\_\_ 97 / 0,78

⚡ 0,03 kW \_\_\_\_\_  
230V~ \_\_\_\_\_  
50/60 Hz \_\_\_\_\_

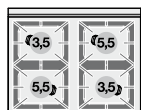

65



Le immagini presentate non sono vincolanti. La ditta si riserva di apportare modifiche senza preavviso. • The pictures are purely representative. The manufacturer reserves the right to modify the technical data and models without previous notice. • Les images

LO

présentées ne nous engageant pas. La Société se réserve le droit d'apporter tout modification sans préavis. • Die dargestellten Abbildungen sind nicht verbindlich. Technische Änderungen vorbehalten. • Las imágenes presentadas no son vinculantes. El Fabricante se reserva el derecho de modificar sus productos sin previo aviso.

01/20

93



# CUCINE A GAS CON FORNO ELETTRICO

MOD. \_\_\_\_\_  
COD. \_\_\_\_\_

DESCRIZIONE/DESCRIPTION/BEZEICHNUNG/DESCRIPTION/DESCRIPCIÓN  
DIMENSIONI/DIMENSIONS/ABMESSUNGEN/DIMENSIONS/DIMENSIONES

POTENZA/POWER/LEISTUNG/PUISSANCE/POTENCIA  
VOLTAGGIO/VOLTAGE/SPANNUNG/VOLTAGE/VOLTAJE

⚡ 18 kW  
15.480 kcal/h

PREZZO/PRICE €  
PREIS/PRIX/PRECIO €  
KG / M<sup>3</sup>

**CF4-8GEM**  
07690860

**CUCINA MISTA 4 FUOCHI CON FORNO ELETTRICO MULTIFUNZIONE - CAMERA CM. 64X37X35H, TEMP: 50÷250°C, CON 1 GRIGLIA CM.53X32,5 GN1/1 - PORTA VETRO EN** Combined range - N. 4 burners Multifunction oven - Chamber cm. 64x37x35h, temp: 50÷250°C ,with 1 grid cm.53x32,5 GN1/1 - Glass door • **DE** Gemischtherd - N. 4 Kochstellen Multifunktions-Ofen cm. 64x37x35h, temp: 50÷250°C ,with 1 grid cm.53x32,5 GN1/1 - Glastür • **FR** Cuisinière mixte - N. 4 feux vifs Four à fonctions multiples cm. 64x37x35h, temp: 50÷250°C ,avec 1 grille cm.53x32,5 GN1/1 - Porte vitrée • **ES** Cocina mixta - N. 4 quemadores Horno multifuncional - Cámara cm. 64x37x35h, temp: 50÷250°C ,con 1 parilla cm.53x32,5 GN1/1 - Puerta vidrio  
**cm. 80x 65x 87h**



⚡ 18 kW  
15.480 kcal/h **3.426,00**  
96 / 0,78

⚡ 3,11 kW  
230V~  
50/60 Hz

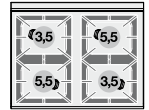

**CF4-8GEM**  
07690861

**CUCINA MISTA 4 FUOCHI CON FORNO ELETTRICO MULTIFUNZIONE - CAMERA CM. 64X37X35H, TEMP: 50÷250°C, CON 1 GRIGLIA CM.53X32,5 GN1/1 - PORTA CIECA INOX EN** Combined range - N. 4 burners Multifunction oven - Chamber cm. 64x37x35h, temp: 50÷250°C ,with 1 grid cm.53x32,5 GN1/1 - Stainless steel door • **DE** Gemischtherd - N. 4 Kochstellen Multifunktions-Ofen cm. 64x37x35h, temp: 50÷250°C ,with 1 grid cm.53x32,5 GN1/1 - Edelstahltür • **FR** Cuisinière mixte - N. 4 feux vifs Four à fonctions multiples cm. 64x37x35h, temp: 50÷250°C ,avec 1 grille cm.53x32,5 GN1/1 - Porte acier inoxydable • **ES** Cocina mixta - N. 4 quemadores Horno multifuncional - Cámara cm. 64x37x35h, temp: 50÷250°C ,con 1 parilla cm.53x32,5 GN1/1 - Puerta ciega inox  
**cm. 80x 65x 87h**



⚡ 18 kW  
15.480 kcal/h **3.426,00**  
96 / 0,78

⚡ 3,11 kW  
230V~  
50/60 Hz

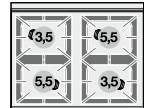

**CF4-8GEMS**  
07690862

**CUCINA MISTA 4 FUOCHI CON FORNO ELETTRICO STATICO C/GRILL CM. 64X42X35H, TEMP: 50÷250°C, CON 1 GRIGLIA CM.53X32,5 GN1/1 - PORTA VETRO EN** Combined range static oven - N. 4 burners Static oven with grill cm. 64x42x35h, temp: 50÷250°C ,with 1 grid cm.53x32,5 GN1/1 - Glass door • **DE** Gemischtherd statischer Ofen - N. 4 Kochstellen Statischer Ofen mit Grill cm. 64x42x35h, temp: 50÷250°C ,with 1 grid cm.53x32,5 GN1/1 - Glastür • **FR** Cuisinière mixte gaz four estático - N. 4 feux vifs Four statique avec grill cm. 64x42x35h, temp: 50÷250°C ,mit 1 Rost cm.53x32,5 GN1/1 - Porte vitrée • **ES** Cocina mixta horno estático - N. 4 quemadores Horno estático con asador cm. 64x42x35h, temp: 50÷250°C ,con 1 parilla cm.53x32,5 GN1/1 - Puerta vidrio  
**cm. 80x 65x 87h**



⚡ 18 kW  
15.480 kcal/h **3.221,00**  
96 / 0,78

⚡ 2,62 kW  
230V~  
50/60 Hz

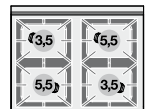

**CF4-8GEMS**  
07690863

**CUCINA MISTA 4 FUOCHI CON FORNO ELETTRICO STATICO C/GRILL CM. 64X42X35H, TEMP: 50÷250°C, CON 1 GRIGLIA CM.53X32,5 GN1/1 - PORTA CIECA INOX EN** Combined range static oven - N. 4 burners Static oven with grill cm. 64x42x35h, temp: 50÷250°C ,with 1 grid cm.53x32,5 GN1/1 - Stainless steel door • **DE** Gemischtherd statischer Ofen - N. 4 Kochstellen Statischer Ofen mit Grill cm. 64x42x35h, temp: 50÷250°C ,with 1 grid cm.53x32,5 GN1/1 - Edelstahltür • **FR** Cuisinière mixte gaz four estático - N. 4 feux vifs Four statique avec grill cm. 64x42x35h, temp: 50÷250°C ,mit 1 Rost cm.53x32,5 GN1/1 - Porte acier inoxydable • **ES** Cocina mixta horno estático - N. 4 quemadores Horno estático con asador cm. 64x42x35h, temp: 50÷250°C ,con 1 parilla cm.53x32,5 GN1/1 - Puerta ciega inox  
**cm. 80x 65x 87h**



⚡ 18 kW  
15.480 kcal/h **3.221,00**  
96 / 0,78

⚡ 2,62 kW  
230V~  
50/60 Hz

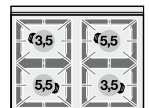

MOD. \_\_\_\_\_  
COD. \_\_\_\_\_

DESCRIZIONE/DESCRIPTION/BEZEICHNUNG/DESCRIPTION/DESCRIPCIÓN  
DIMENSIONI/DIMENSIONS/ABMESSUNGEN/DIMENSIONS/DIMENSIONES

POTENZA/POWER/LEISTUNG/PUISSANCE/POTENCIA  
VOLTAGGIO/VOLTAGE/SPANNUNG/VOLTAGE/VOLTAJE

⚡ kcal/h  
⚡ kW  
V~  
Hz

PREZZO/PRICE €  
PREIS/PRIX/PRECIO  
KG / M<sup>3</sup>

**CP-4ET**  
07100430

**CUOCIPASTA TRIFASE 17 LT. VASCA CM.**  
**31X33,5X20H. N. 2 CESTINI CM. 15X29X15H**  
**- ELETTROVALVOLA CARICO ACQUA -**  
**RUBINETTO SCARICO + SFIORATORE.**  
EN Pasta cooker threephase 17 lts. Tank cm. 31x33,5x20h. N. 2 baskets cm. 15x29x15h - Water loading electro-valve Drain-cock + overflow device • DE Nudelkocher dreiphasig 17 lt. Becken cm. 31x33,5x20h. Wasserlauf Elektroventil - Ablasshahn + Überlaufvorrichtung N. 2 Körbe cm. 15x29x15h • FR Cuiseur à pâtes monophasé 17 lt. Cuve cm. 31x33,5x20h. N. 2 paniers cm. 15x29x15h - Soupape électrique d'arrivée d'eau Robinet de vidange + trop plein • ES Cuece pasta trifásico 17 lt. - Cuba cm 31x33,5x20h. N. 2 cestas cm. 15x29x15h Electroválvula carga agua - Grifo descarga + vertedero  
**cm. 40x 65x 29h**



⚡ 4 kW **1.662,00**  
400V~2N 27 / 0,18  
230V~3  
50/60 Hz

**CP-6ET**  
07100630

**CUOCIPASTA TRIFASE 25 LT. VASCA CM.**  
**51X30,5X20H. N. 3 CESTINI CM. 15X29X15H**  
**- ELETTROVALVOLA CARICO ACQUA -**  
**RUBINETTO SCARICO + SFIORATORE.**  
EN Pasta cooker threephase 25 lts. Tank cm. 51x30,5x20h. N. 3 baskets cm. 15x29x15h - Water loading electro-valve Drain-cock + overflow device • DE Nudelkocher dreiphasig 25 lt. Becken cm. 51x30,5x20h. Wasserlauf Elektroventil - Ablasshahn + Überlaufvorrichtung N. 3 Körbe cm. 15x29x15h • FR Cuiseur à pâtes monophasé 25 lt. Cuve cm. 51x30,5x20h. N. 3 paniers cm. 15x29x15h - Soupape électrique d'arrivée d'eau Robinet de vidange + trop plein • ES Cuece pasta trifásico 25 lt. - Cuba cm 51x30,5x20h. N. 3 cestas cm. 15x29x15h Electroválvula carga agua - Grifo descarga + vertedero  
**cm. 60x 65x 29h**



⚡ 6 kW **2.316,00**  
400V~3N 42 / 0,27  
230V~3  
50/60 Hz

**CP-6G**  
07270650

**CUOCIPASTA GAS - VASCA LT. 27 CM.**  
**46X35X25H - N. 3 CESTI CM. 14,5X29X11H -**  
**RUBINETTO CARICO ACQUA + SFIORATORE**  
EN Gas pasta cooker - Tank capacity 27 lts. 46x35x25h N. 3 baskets cm. 14,5x29x11h Water loading cock + overflow device • DE Gas-Nudelkocher - Beckeninhalt lt. 27 cm. 46x35x25h N. 3 Körbe cm. 14,5x29x11h Wasserlauf Hahn + Überlaufvorrichtung • FR Cuiseur a pâtes gaz - Cuve lt. 27 46x35x25h - N. 3 paniers cm. 14,5x29x11h - Robinet d'arrivée d'eau + trop plein • ES Cuece pasta gas - Cuba 27 lt. cm. 46x35x25h - N. 3 cestas cm. 14,5x29x11h - Grifo carga agua + vertedero  
**cm. 60x 65x 29h**



⚡ 14 kW **2.516,00**  
12.040 kcal/h 47 / 0,27

**CPM-6G**  
07270651

**CUOCIPASTA GAS SU MOBILE - VASCA LT. 40**  
**CM. 51X31X30H. N. 3 CESTI CM. 16X29X20H**  
**RUBINETTO CARICO ACQUA, SFIORATORE +**  
**SCARICO A PAVIMENTO**  
EN Gas pasta cooker on cabinet - Tank capacity 40 lts cm. 51x31x30h. N. 3 baskets cm. 16x29x20h Water loading, cock, overflow device and floor draining • DE Gas-Nudelkocher Standgerät - Inhalt lt. 40 cm. 51x31x30h. N. 3 Körbe cm. 16x29x20h Wasserlauf Hahn, Überlauf und Ablauf am Boden • FR Cuiseur a pâtes sur coffre gaz - Cuve lt. 40 cm. 51x31x30h - N. 3 paniers cm. 16x29x20h - Robinet d'arrivée d'eau, trop plein + système de vidange au sol • ES Cuece pasta gas en mueble - Cuba 40 lt. cm. 51x31x30h. N. 3 cestas cm. 16x29x20h - Grifo carga agua + vertedero + descarga a pavimento  
**cm. 60x 65x 87h**



⚡ 13,5 kW **4.032,00**  
11.600 kcal/h 84 / 0,59

MOD. \_\_\_\_\_  
COD. \_\_\_\_\_

DESCRIZIONE/DESCRIPTION/BEZEICHNUNG/DESCRIPTION/DESCRIPCIÓN  
DIMENSIONI/DIMENSIONS/ABMESSUNGEN/DIMENSIONS/DIMENSIONES

POTENZA/POWER/LEISTUNG/PUISSANCE/POTENCIA  
VOLTAGGIO/VOLTAGE/SPANNUNG/VOLTAGE/VOLTAJE

⚡ kW kcal/h  
⚡ kW V~ Hz

PREZZO/PRICE €  
PREIS/PRIX/PRECIO €  
KG / M<sup>3</sup>

**CW-4ET**  
07080430

**GRIGLIA ELETTRICA TRIFASE GRIGLIA IN ACCIAIO INOX CM. 38X47 REGOLABILE.**  
**EN** Electric grill threephase - Stainless steel adjustable grill cm. 38x47 • **DE** Elektro-Wurstbrater dreiphasig - Einstellbarer Rost aus Nirosta (cm. 38x47) • **FR** Grillade électrique triphase réglable - Grille inox cm 38x47 • **ES** Parrilla eléctrica trifásica - Parrilla de acero inox regulable 38x47 cm  
**cm. 40x 65x 29h**



⚡ 6 kW 1.542,00  
400V~3N 35.5 / 0,18  
230V~3  
50/60 Hz

**CW-6ET**  
07080630

**GRIGLIA ELETTRICA TRIFASE N. 2 GRIGLIE IN ACCIAIO INOX CM. 28X47 REGOLABILI 2 ZONE DI COTTURA**  
**EN** Electric grill threephase - N. 2 adjustable stainless steel grills cm. 28x47 - 2 cooking areas • **DE** Elektro-Wurstbrater dreiphasig - Nr. 2 einstellbare Roste aus Nirosta (cm. 28x47) - 2 Heizzone • **FR** Grillade électrique triphase - N. 2 grilles inox réglable cm 28x47 - 2 zones de cuisson • **ES** Parrilla eléctrica trifásica - N. 2 parrillas de acero inox regulable 28x47 cm - 2 zonas de cocción  
**cm. 60x 65x 29h**



⚡ 8 kW 2.270,00  
400V~3N 48 / 0,27  
230V~3  
50/60 Hz

**CW-4G**  
07250450

**GRIGLIA A GAS-PIETRALAVICA GRIGLIA IN ACCIAIO INOX CM. 38X47 REGOLABILE.**  
**EN** Charcoal grill gas - Stainless steel adjustable grill cm. 38x47 • **DE** Gas Lavasteingrill - Einstellbarer Rost aus Nirosta (cm. 38x47) • **FR** Grille a gaz en pierre de lave Grille réglable en acier inox cm. 38x47 • **ES** Parrilla a gas piedra lávica Parrilla de acero inox regulable 38x47 cm  
**cm. 40x 65x 29h**



⚡ 6,5 kW 1.816,00  
5.590 kcal/h 41.5 / 0,18

**CW-6G**  
07250650

**GRIGLIA A GAS-PIETRALAVICA - N. 2 GRIGLIE IN ACCIAIO INOX CM. 28X47 REGOLABILI. 2 ZONE DI COTTURA**  
**EN** Charcoal grill gas - N. 2 Stainless steel adjustable grill cm. 28x47 - 2 cooking areas • **DE** Gas Lavasteingrill - Nr. 2 einstellbare Roste aus Nirosta (cm. 28x47) - 2 Heizzonen • **FR** Grille à gaz en pierre de lave - N. 2 grilles réglables en acier inox - cm. 28x47 - 2 zones de cuisson • **ES** Parrilla a gas piedra lávica - Parrilla de acero inox regulable 28x47 cm - 2 zonas de cocción  
**cm. 60x 65x 29h**



⚡ 9,8 kW 2.689,00  
8.420 kcal/h 58.5 / 0,27

**FQ-4EM**  
07090410

**FRIGGITRICE VASCA LT. 10 CM. 22X35X22H - CESTO CM. 20X30X10H PRODUZIONE PATATE 8 KG/H**  
**EN** Fryer - Tank capacity 10 lts. cm. 22x35x22h Basket cm. 20x30x10h - Production 8 kg/hr • **DE** Friteuse - Becken lt. 10 cm. 22x35x22h Korb cm. 20x30x10h - Pommes frites 8 kg/pro Stunde • **FR** Friteuse - Cuve 10 lt. cm. 22x35x22h - Panier cm 20x30x10h - Production de pommes frites 8 kg/h • **ES** Freidora - Cuba 10 lt. - cm. 22x35x22h Cesta cm. 20x30x10h - Producción patatas 8 Kg/h  
**cm. 40x 65x 29h**



⚡ 3,6 kW 1.077,00  
230V~ 25.5 / 0,18  
50/60 Hz

# FRIGGITRICI ELETTRICHE

MOD. \_\_\_\_\_  
COD. \_\_\_\_\_

DESCRIZIONE/DESCRIPTION/BEZEICHNUNG/DESCRIPTION/DESCRIPCIÓN  
DIMENSIONI/DIMENSIONS/ABMESSUNGEN/DIMENSIONS/DIMENSIONES

POTENZA/POWER/LEISTUNG/PUISSANCE/POTENCIA  
VOLTAGGIO/VOLTAGE/SPANNUNG/VOLTAGE/VOLTAJE

$\frac{kW}{kcal/h}$   $\frac{V}{Hz}$

PREZZO/PRICE €  
PREIS/PRIX/PRECIO €  
KG / M<sup>3</sup>

**FQ-4ET**  
07090430

**FRIGGITRICE TRIFASE VASCA LT. 10 CM.  
22X35X22H - CESTO CM. 20X30X10H  
PRODUZIONE PATATE 10 KG/H**  
EN Fryer threephase - Tank capacity 10 lts. cm. 22x35x22h Basket cm. 20x30x10h - Production 10 kg/hr • DE Friteuse dreiphasig - Becken lt. 10 cm. 22x35x22h Körb cm. 20x30x10h - Pommes frites 10 kg/pro Stunde • FR Friteuse triphase - Cuve 10 lt. cm. 22x35x22h - Panier cm 20x30x10h - Production de pommes frites 10 Kg/h • ES Freidora trifásica - Cuba 10 lt. - cm. 22x35x22h Cesta cm. 20x30x10h - Producción patatas 10 Kg/h  
**cm. 40x 65x 29h**



$\frac{7,15 kW}{400V-3N}$  **1.228,00**  
 $\frac{230V-3}{50/60 Hz}$  26.5 / 0,18

**FQ-6EM**  
07090610

**FRIGGITRICE 2 VASCHE LT. 10 CM.  
22X35X22H - 2 CESTI CM. 20X30X10H  
PRODUZIONE PATATE 16 KG/H**  
EN Fryer - 2 Tanks capacity 10 lts. cm. 22x35x22h - 2 Baskets cm. 20x30x10h - Production 16 kg/hr • DE Friteuse - 2 Becken lt. 10 cm. 22x35x22h - 2 Körbe cm. 20x30x10h - Pommes frites 16 kg/pro Stunde • FR Friteuse - 2 Cuves 10 l. cm. 22x35x22h - 2 Paniers cm 20x30x10h - Production de pommes frites 16 kg/h • ES Freidora - 2 Cubas 10 l. cm. 22x35x22h - 2 Cestas cm 20x30x10h - Producción patatas 16 Kg/h  
**cm. 60x 65x 29h**



$\frac{7,2 KW}{230V-}$  **2.162,00**  
 $\frac{50/60 Hz}{}$  39.5 / 0,27

**FQ-6ET**  
07090630

**FRIGGITRICE TRIFASE 2 VASCHE LT. 10 CM.  
22X35X22H - 2 CESTI CM. 20X30X10H  
PRODUZIONE PATATE 20 KG/H**  
EN Fryer threephase - 2 Tanks capacity 10 lts. cm. 22x35x22h - 2 Baskets cm. 20x30x10h - Production 20 kg/hr • DE Friteuse dreiphasig - 2 Becken lt. 10 cm. 22x35x22h - 2 Körbe cm. 20x30x10h - Pommes frites 20 kg/pro Stunde • FR Friteuse triphase - 2 Cuves 10 l. cm. 22x35x22h - 2 Paniers cm 20x30x10h - Production de pommes frites 20 Kg/h • ES Freidora trifásica - 2 Cubas 10 l. cm. 22x35x22h - 2 Cestas cm 20x30x10h - Producción patatas 20 Kg/h  
**cm. 60x 65x 29h**

$\frac{14,3 kW}{400V-3N}$  **2.280,00**  
 $\frac{230V-3}{50/60 Hz}$  41.5 / 0,27

**FP-6ET**  
07091630

**FRIGGITRICE VASCA LT. 23 CM. 50X35X22H -  
CESTO CM. 46X30X10H**  
EN Fryer - Tank capacity 23 lts. cm. 50x35x24h Basket cm. 46x30x10h • DE Friteuse - Becken lt. 23 cm. 50x35x22h Körb cm. 46x30x10h • FR Friteuse - Cuve 23 l. cm. 50x35x22h Panier cm 46x30x10h • ES Freidora - Cuba 23 l. cm. 50x35x22h Cesta cm. 46x30x10h  
**cm. 60x 65x 29h**

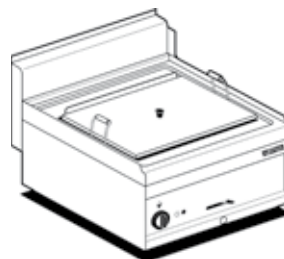

$\frac{14,3 kW}{400V-3N}$  **1.899,00**  
 $\frac{50/60 Hz}{}$  40 / 0,27

**FQ-4G**  
07260450

**FRIGGITRICE GAS - VASCA LT. 10  
CM.22X35X25H CESTO CM. 20X30X10H -  
PRODUZIONE PATATE: 10 KG/H**  
EN Gas fryer - Tank capacity 10 lts. cm.22x35x25h Basket cm. 20x30x10h - Production: 10 kg/h • DE Gas-Einzelfriteuse - Beckeninhalte lt. 10 cm.22x35x25h Korb cm. 20x30x10h - Pommes frites: 10 kg/pro Stunde • FR Friteuse gaz - Cuve lt. 10. cm.22x35x25h Panier cm. 20x30x10h - Production de pommes frites: 10 kg/h • ES Freidoras gas - Cuba 10 l. cm22x35x25h Cesta cm. 20x30x10h - Producción patatas: 10 Kg/h  
**cm. 40x 65x 29h**



$\frac{7 kW}{6.020 kcal/h}$  **1.661,00**  
30 / 0,18



Le immagini presentate non sono vincolanti. La ditta si riserva di apportare modifiche senza preavviso. • The pictures are purely representative. The manufacturer reserves the right to modify the technical data and models without previous notice. • Les images

LO

présentées ne nous engagent pas. La Société se réserve le droit d'apporter tout modification sans préavis. • Die dargestellten Abbildungen sind nicht verbindlich. Technische Änderungen vorbehalten. • Las imágenes presentadas no son vinculantes. El Fabricante se reserva el derecho de modificar sus productos sin previo aviso.

01/20

97

65



# FRIGGITRICI A GAS

MOD. \_\_\_\_\_  
COD. \_\_\_\_\_

DESCRIZIONE/DESCRIPTION/BEZEICHNUNG/DESCRIPTION/DESCRIPCIÓN  
DIMENSIONI/DIMENSIONS/ABMESSUNGEN/DIMENSIONS/DIMENSIONES

POTENZA/POWER/LEISTUNG/PUISSANCE/POTENCIA  
VOLTAGGIO/VOLTAGE/SPANNUNG/VOLTAGE/VOLTAJE

14 kW  
12.040 kcal/h

PREZZO/PRICE €  
PREIS/PRIX/PRECIO €  
KG / M<sup>3</sup>

**FQ-6G**  
07260650

**FRIGGITRICE GAS - 2 VASCHE LT. 10  
CM.22X35X25H 2 CESTI CM. 20X30X10H -  
PRODUZIONE PATATE: 20 KG/H**

**EN** Gas fryer - 2 tanks capacity 10 lts. cm.22x35x25h  
2 baskets cm. 20x30x10h - Production: 20 kg/h  
• **DE** Gas-Doppel-friteuse - lt. 10 + 10 Becken cm.  
22x35x25h - 2 Korbe cm.20x30x10h Pommes frites:  
20 kg/pro Stunde • **FR** Friteuse gaz - 2 Cuves 10 lt.  
cm.22x35x25h 2 Paniers cm. 20x30x10h Production de  
pommes frites: 20 kg/h • **ES** Freidoras gas - 2 Cuba 10  
l. cm22x35x25h 2 cestas cm. 20x30x10h - Producción  
patatas: 20 Kg/h  
**cm. 60x 65x 29h**



14 kW  
12.040 kcal/h **2.619,00**  
48.5 / 0,27

**FP-6G**  
07260652

**FRIGGITRICE GAS - VASCA LT. 20  
CM.46X35X25H CESTO CM. 42,5X31X10H**

**EN** Gas fryer - Tank capacity 20 lts. cm. 46x35x25h  
Basket cm. 42,5x31x10h • **DE** Gas-Einzel-friteuse  
- Beckeninhalt lt. 20 cm. 46x35x25h Korb cm.  
42,5x31x10h • **FR** Friteuse gaz - Cuve lt. 20 cm.  
46x35x25h Panier cm. 42,5x31x10h • **ES** Freidoras  
gas - Cuba 20 lt. 46x35x25h cm. Cesta cm.  
42,5x31x10h  
**cm. 60x 65x 29h**



14 kW  
12.040 kcal/h **2.182,00**  
44.5 / 0,27

**FQM-4G**  
07260451

**FRIGGITRICE GAS SU MOBILE - VASCA LT. 15  
CM. 33X38X38H - CESTO CM. 30X33X12H -  
BACINELLA RACCOGLI OLIO CON FILTRO -  
PRODUZIONE PATATE: 15 KG/H**

**EN** Gas fryer on cabinet - Tank capacity 15 lts.cm.  
33x38x38h - Basket cm. 30x33x12h Production: 15  
kg/h - Drip tray with sieve • **DE** Gas-Stand-friteuse -  
Beckeninhalt lt. 15 cm.33x38x38h Korb cm. 30x33x12h  
- Fettauffangschale mit Sieb, Pommes frites: 15 kg/  
pro Stunde • **FR** Friteuse gaz sur placard - Cuve lt 15  
cm.33x38x38h Panier cm. 30x33x12h - Production  
de pommes frites: 15 kg/h - Bac de récupération de  
l'huile et filtre • **ES** Freidora gas en mueble - Cuba 15 l.  
cm33x38x38h Cesta cm. 30x33x12h - Bandeja recoge  
aceite con filtro Producción patatas: 15 Kg/h  
**cm. 40x 65x 87h**



13,5 kW  
11.650 kcal/h **2.270,00**  
60 / 0,40

**FTL-4EM**  
07060411

**FRY-TOP ELETTRICO LISCIO, PIASTRA  
CM.35,5X55**

**EN** Electric Fry-top smooth griddle, plate cm.35,5x55  
• **DE** Griddleplatte elektrische glatt, platte cm.35,5x55  
• **FR** Plaque électriques lisse, plaque cm.35,5x55 • **ES**  
Fry-top eléctrico liso, plancha cm.35,5x55  
**cm. 40x 65x 29h**



3 kW  
230V~  
50/60 Hz **996,00**  
49 / 0,18

**FTL-4ET**  
07060431

**cm. 40x 65x 29h**

4,5 kW  
400V~3N  
230V~3  
50/60 Hz **1.068,00**  
49 / 0,18

**FTL-4EMS**  
07060414

**FRY-TOP ELETTRICO LISCIO CROMATO,  
PIASTRA CM.35,5X55**

**EN** Electric Fry-top smooth chromed griddle, plate  
cm.35,5x55 • **DE** Griddleplatte elektrische glatt  
hartverchromt, platte cm.35,5x55 • **FR** Plaque  
électriques lisse chromée, plaque cm.35,5x55 • **ES** Fry-  
top eléctrico liso cromado, plancha cm.35,5x55  
**cm. 40x 65x 29h**

3 kW  
230V~  
50/60 Hz **1.270,00**  
49 / 0,18



# FRY-TOP ELETTRICI

MOD. \_\_\_\_\_  
COD. \_\_\_\_\_

DESCRIZIONE/DESCRIPTION/BEZEICHNUNG/DESCRIPTION/DESCRIPCIÓN  
DIMENSIONI/DIMENSIONS/ABMESSUNGEN/DIMENSIONS/DIMENSIONES

POTENZA/POWER/LEISTUNG/PUISSANCE/POTENCIA  
VOLTAGGIO/VOLTAGE/SPANNUNG/VOLTAGE/VOLTAJE

⚡ kW  
kcal/h

⚡ kw  
V~  
Hz

PREZZO/PRICE €  
PREIS/PRIX/PRECIO €  
KG / M<sup>3</sup>

**FTR-4ETS** cm. 40x 65x 29h  
07060434



⚡ 4,5 kW **1.372,00**  
400V~3N 49 / 0,18  
230V~3  
50/60 Hz

**FTR-4EM** **FRY-TOP ELETTRICO RIGATO, PIASTRA**  
07060413 **CM.35,5X55**

**EN** Electric Fry-top grooved griddle, plate cm.35,5x55  
• **DE** Griddleplatte elektrische gerillt, platte cm.35,5x55  
• **FR** Plaque électriques nervurée, plaque cm.35,5x55  
• **ES** Fry-top eléctrico estriado, plancha cm.35,5x55  
**cm. 40x 65x 29h**

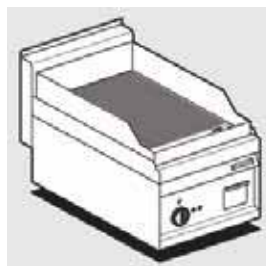

⚡ 3 kW **1.158,00**  
230V~ 49 / 0,18  
50/60 Hz

**FTR-4ET** cm. 40x 65x 29h  
07060433

⚡ 4,5 kW **1.205,00**  
400V~3N 49 / 0,18  
230V~3  
50/60 Hz

**FTR-4EMS** **FRY-TOP ELETTRICO RIGATO CROMATO,**  
07060416 **PIASTRA CM.35,5X55**

**EN** Electric Fry-top grooved chromed griddle, plate cm.35,5x55  
• **DE** Griddleplatte elektrische gerillt hartverchromt, platte cm.35,5x55  
• **FR** Plaque électriques nervurée chromée, plaque cm.35,5x55  
• **ES** Fry-top eléctrico estriado cromado, plancha cm.35,5x55  
**cm. 40x 65x 29h**

⚡ 3 kW **1.409,00**  
230V~ 49 / 0,18  
50/60 Hz

**FTR-4ETS** cm. 40x 65x 29h  
07060436

⚡ 4,5 kW **1.507,00**  
400V~3N 49 / 0,18  
230V~3  
50/60 Hz

**FTR-6ET** **FRY-TOP ELETTRICO LISCIO, PIASTRA**  
07060631 **CM.55,5X55 - 2 ZONE DI COTTURA**

**EN** Electric Fry-top smooth griddle, plate cm.55,5x55 - 2 cooking areas  
• **DE** Griddleplatte elektrische glatt, platte cm.55,5x55 - 2 Heizzonen  
• **FR** Plaque électriques lisse, plaque cm.55,5x55 - 2 zones de cuisson  
• **ES** Fry-top eléctrico liso, plancha cm.55,5x55 - 2 zonas de cocción  
**cm. 60x 65x 29h**

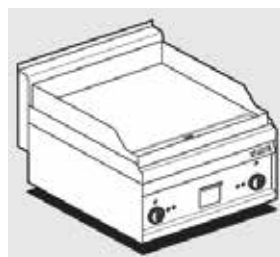

⚡ 6 kW **1.458,00**  
400V~3N 66.5 / 0,27  
230V~3  
230V~  
50/60 Hz

**FTR-6ETS** **FRY-TOP ELETTRICO LISCIO CROMATO,**  
07060634 **PIASTRA CM.55,5X55 - 2 ZONE DI COTTURA**

**EN** Electric Fry-top smooth chromed griddle, plate cm.55,5x55 - 2 cooking areas  
• **DE** Griddleplatte elektrische glatt hartverchromt, platte cm.55,5x55 - 2 Heizzonen  
• **FR** Plaque électriques lisse chromée, plaque cm.55,5x55 - 2 zones de cuisson  
• **ES** Fry-top eléctrico liso cromado, plancha cm.55,5x55 - 2 zonas de cocción  
**cm. 60x 65x 29h**

⚡ 6 kW **1.979,00**  
400V~3N 66.5 / 0,27  
230V~3  
230V~  
50/60 Hz

65



Le immagini presentate non sono vincolanti. La ditta si riserva di apportare modifiche senza preavviso. • The pictures are purely representative. The manufacturer reserves the right to modify the technical data and models without previous notice. • Les images

LO

présentées ne nous engagent pas. La Société se réserve le droit d'apporter tout modification sans préavis. • Die dargestellten Abbildungen sind nicht verbindlich. Technische Änderungen vorbehalten. • Las imágenes presentadas no son vinculantes. El Fabricante se reserva el derecho de modificar sus productos sin previo aviso.

01/20

99

# FRY-TOP ELETTRICI

MOD. \_\_\_\_\_  
COD. \_\_\_\_\_

DESCRIZIONE/DESCRIPTION/BEZEICHNUNG/DESCRIPTION/DESCRIPCIÓN  
DIMENSIONI/DIMENSIONS/ABMESSUNGEN/DIMENSIONS/DIMENSIONES

POTENZA/POWER/LEISTUNG/PUISSANCE/POTENCIA  
VOLTAGGIO/VOLTAGE/SPANNUNG/VOLTAGE/VOLTAJE

⚡ kW kcal/h  
V~ Hz

PREZZO/PRICE €  
PREIS/PRIX/PRECIO €  
KG / M<sup>3</sup>

**FTLR-6ET**  
07060632

**FRY-TOP ELETTRICO 1/2 RIGATO + 1/2 LISCIO, PIASTRA CM.55,5X55 - 2 ZONE DI COTTURA**

**EN** Electric Fry-top 1/2 grooved + 1/2 smooth, plate cm.55,5x55 - 2 cooking areas • **DE** Griddleplatte elektrische 1/2 gerillt + 1/2 glatt, platte cm.55,5x55 - 2 Heizzonen • **FR** Plaque électriques 1/2 nervurée + 1/2 lisse, plaque cm.55,5x55 - 2 zones de cuisson • **ES** Fry-top eléctrico 1/2 estriado + 1/2 liso, plancha cm.55,5x55 - 2 zonas de cocción  
**cm. 60x 65x 29h**

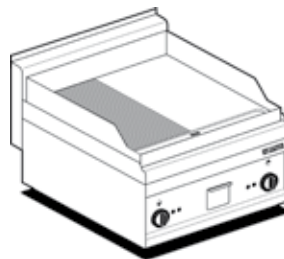

⚡ 6 kW 1.595,00  
400V~3N 66.5 / 0,27  
230V~3  
230V~  
50/60 Hz



**FTLR-6ETS**  
07060635

**FRY-TOP ELETTRICO 1/2 RIGATO + 1/2 LISCIO CROMATO, PIASTRA CM.55,5X55 - 2 ZONE DI COTTURA**

**EN** Electric Fry-top 1/2 grooved + 1/2 smooth chromed griddle, plate cm.55,5x55 - 2 cooking areas • **DE** Griddleplatte elektrische 1/2 gerillt + 1/2 glatt hartverchromt, platte cm.55,5x55 - 2 Heizzonen • **FR** Plaque électriques 1/2 nervurée + 1/2 lisse chromée, plaque cm.55,5x55 - 2 zones de cuisson • **ES** Fry-top eléctrico 1/2 estriado + 1/2 liso cromado, plancha cm.55,5x55 - 2 zonas de cocción  
**cm. 60x 65x 29h**

⚡ 6 kW 2.117,00  
400V~3N 66.5 / 0,27  
230V~3  
230V~  
50/60 Hz



**FTR-6ET**  
07060633

**FRY-TOP ELETTRICO RIGATO, PIASTRA CM.55,5X55 - 2 ZONE DI COTTURA**

**EN** Electric Fry-top grooved griddle, plate cm.55,5x55 - 2 cooking areas • **DE** Griddleplatte elektrische gerillt, platte cm.55,5x55 - 2 Heizzonen • **FR** Plaque électriques nervurée, plaque cm.55,5x55 - 2 zones de cuisson • **ES** Fry-top eléctrico estriado, plancha cm.55,5x55 - 2 zonas de cocción  
**cm. 60x 65x 29h**

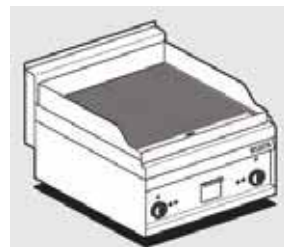

⚡ 6 kW 1.731,00  
400V~3N 66.5 / 0,27  
230V~3  
230V~  
50/60 Hz



**FTR-6ETS**  
07060636

**FRY-TOP ELETTRICO RIGATO CROMATO, PIASTRA CM.55,5X55 - 2 ZONE DI COTTURA**

**EN** Electric Fry-top grooved chromed griddle, plate cm.55,5x55 - 2 cooking areas • **DE** Griddleplatte elektrische gerillt hartverchromt, platte cm.55,5x55 - 2 Heizzonen • **FR** Plaque électriques nervurée chromée, plaque cm.55,5x55 - 2 zones de cuisson • **ES** Fry-top eléctrico estriado cromado, plancha cm.55,5x55 - 2 zonas de cocción  
**cm. 60x 65x 29h**

⚡ 6 kW 2.255,00  
400V~3N 66.5 / 0,27  
230V~3  
230V~  
50/60 Hz



**FTL-8ET**  
07060831

**FRY-TOP ELETTRICO LISCIO, PIASTRA CM.75,5X55 - 2 ZONE DI COTTURA**

**EN** Electric Fry-top smooth griddle, plate cm.75,5x55 - 2 cooking areas • **DE** Griddleplatte elektrische glatt, platte cm.75,5x55 - 2 Heizzonen • **FR** Plaque électriques lisse, plaque cm.75,5x55 - 2 zones de cuisson • **ES** Fry-top eléctrico liso, plancha cm.75,5x55 - 2 zonas de cocción  
**cm. 80x 65x 29h**

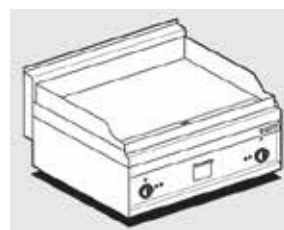

⚡ 9 kW 2.016,00  
400V~3N 82 / 0,35  
230V~3  
50/60 Hz



**FTL-8ETS**  
07060834

**FRY-TOP ELETTRICO LISCIO CROMATO, PIASTRA CM.75,5X55 - 2 ZONE DI COTTURA**

**EN** Electric Fry-top smooth chromed griddle, plate cm.75,5x55 - 2 cooking areas • **DE** Griddleplatte elektrische glatt hartverchromt, platte cm.75,5x55 - 2 Heizzonen • **FR** Plaque électriques lisse chromée, plaque cm.75,5x55 - 2 zones de cuisson • **ES** Fry-top eléctrico liso cromado, plancha cm.75,5x55 - 2 zonas de cocción  
**cm. 80x 65x 29h**

⚡ 9 kW 2.638,00  
400V~3N 82 / 0,35  
230V~3  
50/60 Hz



# FRY-TOP ELETTRICI

MOD. \_\_\_\_\_  
COD. \_\_\_\_\_

DESCRIZIONE/DESCRIPTION/BEZEICHNUNG/DESCRIPTION/DESCRIPCIÓN  
DIMENSIONI/DIMENSIONS/ABMESSUNGEN/DIMENSIONS/DIMENSIONES

POTENZA/POWER/LEISTUNG/PUISSANCE/POTENCIA  
VOLTAGGIO/VOLTAGE/SPANNUNG/VOLTAGE/VOLTAJE

⚡ kW  
kcal/h

⚡ kW  
V~  
Hz

PREZZO/PRICE €  
PREIS/PRIX/PRECIO €  
KG / M<sup>3</sup>

**FTLR-8ET**  
07060832

**FRY-TOP ELETTRICO 1/2 RIGATO + 1/2 LISCIO, PIASTRA CM.75,5X55 - 2 ZONE DI COTTURA**

**EN** Electric Fry-top 1/2 grooved + 1/2 smooth, plate cm.75,5x55 - 2 cooking areas • **DE** Griddleplatte elektrische 1/2 gerillt + 1/2 glatt, platte cm.75,5x55 - 2 Heizzonen • **FR** Plaque électriques 1/2 nervurée + 1/2 lisse, plaque cm.75,5x55 - 2 zones de cuisson • **ES** Fry-top eléctrico 1/2 estriado + 1/2 liso, plancha cm.75,5x55 - 2 zonas de cocción  
**cm. 80x 65x 29h**



⚡ 9 kW  
400V~3N  
230V~3  
50/60 Hz

**2.164,00**  
82 / 0,35



**FTLR-8ETS**  
07060835

**FRY-TOP ELETTRICO 1/2 RIGATO + 1/2 LISCIO CROMATO, PIASTRA CM.75,5X55 - 2 ZONE DI COTTURA**

**EN** Electric Fry-top 1/2 grooved + 1/2 smooth chromed griddle, plate cm.75,5x55 - 2 cooking areas • **DE** Griddleplatte elektrische 1/2 gerillt + 1/2 glatt hartverchromt, platte cm.75,5x55 - 2 Heizzonen • **FR** Plaque électriques 1/2 nervurée + 1/2 lisse chromée, plaque cm.75,5x55 - 2 zones de cuisson • **ES** Fry-top eléctrico 1/2 estriado + 1/2 liso cromado, plancha cm.75,5x55 - 2 zonas de cocción  
**cm. 80x 65x 29h**

⚡ 9 kW  
400V~3N  
230V~3  
50/60 Hz

**2.798,00**  
82 / 0,35



**FTL-4G**  
07230451

**FRY-TOP GAS LISCIO, PIASTRA CM.35,5X55**

**EN** Gas Fry-top smooth griddle, plate cm.35,5x55 • **DE** Gas-griddleplatte glatt, platte cm.35,5x55 • **FR** Plaque gaz lisse, plaque cm.35,5x55 • **ES** Fry-top gas liso, plancha cm.35,5x55  
**cm. 40x 65x 29h**



⚡ 7 kW  
6.020 kcal/h

**1.261,00**  
46 / 0,18



**FTL-4GS**  
07230454

**FRY-TOP GAS LISCIO CROMATO, PIASTRA CM.35,5X55**

**EN** Gas Fry-top smooth chromed griddle, plate cm.35,5x55 • **DE** Gas-griddleplatte glatt hartverchromt, platte cm.35,5x55 • **FR** Plaque gaz lisse chromée, plaque cm.35,5x55 • **ES** Fry-top gas liso cromado, plancha cm.35,5x55  
**cm. 40x 65x 29h**

⚡ 7 kW  
6.020 kcal/h

**1.718,00**  
46 / 0,18



**FTR-4G**  
07230453

**FRY-TOP GAS RIGATO, PIASTRA CM.35,5X55**

**EN** Gas Fry-top grooved griddle, plate cm.35,5x55 • **DE** Gas-griddleplatte gerillt, platte cm.35,5x55 • **FR** Plaque gaz nervurée, plaque cm.35,5x55 • **ES** Fry-top gas estriado, plancha cm.35,5x55  
**cm. 40x 65x 29h**



⚡ 7 kW  
6.020 kcal/h

**1.421,00**  
46 / 0,18



**FTR-4GS**  
07230456

**FRY-TOP GAS RIGATO CROMATO, PIASTRA CM.35,5X55**

**EN** Gas Fry-top grooved chromed griddle, plate cm.35,5x55 • **DE** Gas-griddleplatte gerillt hartverchromt, platte cm.35,5x55 • **FR** Plaque gaz nervurée chromée, plaque cm.35,5x55 • **ES** Fry-top gas estriado cromado, plancha cm.35,5x55  
**cm. 40x 65x 29h**

⚡ 7 kW  
6.020 kcal/h

**1.867,00**  
46 / 0,18



**FTL-6G**  
07230651

**FRY-TOP GAS LISCIO, PIASTRA CM.55,5X55 - 2 ZONE DI COTTURA**

**EN** Gas Fry-top smooth griddle, plate cm.55,5x55 - 2 cooking areas • **DE** Gas-griddleplatte glatt, platte cm.55,5x55 - 2 Heizzonen • **FR** Plaque gaz lisse, plaque cm.55,5x55 - 2 zones de cuisson • **ES** Fry-top gas liso, plancha cm.55,5x55 - 2 zonas de cocción  
**cm. 60x 65x 29h**



⚡ 10,5 kW  
9.030 kcal/h

**1.676,00**  
65.5 / 0,27

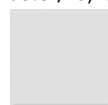

65



Le immagini presentate non sono vincolanti. La ditta si riserva di apportare modifiche senza preavviso. • The pictures are purely representative. The manufacturer reserves the right to modify the technical data and models without previous notice. • Les images

LO

présentées ne nous engagent pas. La Société se réserve le droit d'apporter tout modification sans préavis. • Die dargestellten Abbildungen sind nicht verbindlich. Technische Änderungen vorbehalten. • Las imágenes presentadas no son vinculantes. El Fabricante se reserva el derecho de modificar sus productos sin previo aviso.

01/20

101

# FRY-TOP A GAS

MOD. \_\_\_\_\_  
COD. \_\_\_\_\_

DESCRIZIONE/DESCRIPTION/BEZEICHNUNG/DESCRIPTION/DESCRIPCIÓN  
DIMENSIONI/DIMENSIONS/ABMESSUNGEN/DIMENSIONS/DIMENSIONES

POTENZA/POWER/LEISTUNG/PUISSANCE/POTENCIA  
VOLTAGGIO/VOLTAGE/SPANNUNG/VOLTAGE/VOLTAJE

10,5 kW  
9.030 kcal/h

PREZZO/PRICE €  
PREIS/PRIX/PRECIO €  
KG / M<sup>3</sup>

**FTL-6GS**  
07230654

**FRY-TOP GAS LISCIO CROMATO, PIASTRA CM.55,5X55 - 2 ZONE DI COTTURA**  
**EN** Gas Fry-top smooth chromed griddle, plate cm.55,5x55 - 2 cooking areas • **DE** Gas-griddleplatte glatt hartverchromt, platte cm.55,5x55 - 2 Heizzonen • **FR** Plaque gaz lisse chromée, plaque cm.55,5x55 - 2 zones de cuisson • **ES** Fry-top gas liso cromado, plancha cm.55,5x55 - 2 zonas de cocción  
**cm. 60x 65x 29h**

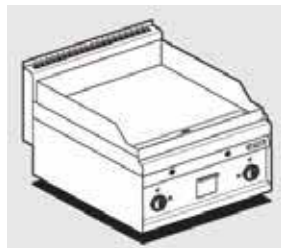

10,5 kW  
9.030 kcal/h

**2.194,00**  
65.5 / 0,27

**FTLR-6G**  
07230652

**FRY-TOP GAS 1/2 RIGATO + 1/2 LISCIO, PIASTRA CM.55,5X55 - 2 ZONE DI COTTURA**  
**EN** Gas Fry-top 1/2 grooved + 1/2 smooth, plate cm.55,5x55 - 2 cooking areas • **DE** Gas-griddleplatte 1/2 gerillt + 1/2 glatt, platte cm.55,5x55 - 2 Heizzonen • **FR** Plaque gaz 1/2 nervurée + 1/2 lisse, plaque cm.55,5x55 - 2 zones de cuisson • **ES** Fry-top gas 1/2 estriado + 1/2 liso, plancha cm.55,5x55 - 2 zonas de cocción  
**cm. 60x 65x 29h**



10,5 kW  
9.030 kcal/h

**1.815,00**  
65.5 / 0,27

**FTLR-6GS**  
07230655

**FRY-TOP GAS 1/2 RIGATO + 1/2 LISCIO CROMATO, PIASTRA CM.55,5X55 - 2 ZONE DI COTTURA**  
**EN** Gas Fry-top 1/2 grooved + 1/2 smooth chromed griddle, plate cm.55,5x55 - 2 cooking areas • **DE** Gas-griddleplatte 1/2 gerillt + 1/2 glatt hartverchromt, platte cm.55,5x55 - 2 Heizzonen • **FR** Plaque gaz 1/2 nervurée + 1/2 lisse chromée, plaque cm.55,5x55 - 2 zones de cuisson • **ES** Fry-top gas 1/2 estriado + 1/2 liso cromado, plancha cm.55,5x55 - 2 zonas de cocción  
**cm. 60x 65x 29h**

10,5 kW  
9.030 kcal/h

**2.342,00**  
65.5 / 0,27

**FTR-6G**  
07230653

**FRY-TOP GAS RIGATO, PIASTRA CM.55,5X55 - 2 ZONE DI COTTURA**  
**EN** Gas Fry-top grooved griddle, plate cm.55,5x55 - 2 cooking areas • **DE** Gas-griddleplatte gerillt, platte cm.55,5x55 - 2 Heizzonen • **FR** Plaque gaz nervurée, plaque cm.55,5x55 - 2 zones de cuisson • **ES** Fry-top gas estriado, plancha cm.55,5x55 - 2 zonas de cocción  
**cm. 60x 65x 29h**



10,5 kW  
9.030 kcal/h

**1.964,00**  
65.5 / 0,27

**FTR-6GS**  
07230656

**FRY-TOP GAS RIGATO CROMATO, PIASTRA CM.55,5X55 - 2 ZONE DI COTTURA**  
**EN** Gas Fry-top grooved chromed griddle, plate cm.55,5x55 - 2 cooking areas • **DE** Gas-griddleplatte gerillt hartverchromt, platte cm.55,5x55 - 2 Heizzonen • **FR** Plaque gaz nervurée chromée, plaque cm.55,5x55 - 2 zones de cuisson • **ES** Fry-top gas estriado cromado, plancha cm.55,5x55 - 2 zonas de cocción  
**cm. 60x 65x 29h**

10,5 kW  
9.030 kcal/h

**2.488,00**  
65.5 / 0,27

**FTL-8G**  
07230851

**FRY-TOP GAS LISCIO, PIASTRA CM.75,5X55 - 2 ZONE DI COTTURA**  
**EN** Gas Fry-top smooth griddle, plate cm.75,5x55 - 2 cooking areas • **DE** Gas-griddleplatte glatt, platte cm.75,5x55 - 2 Heizzonen • **FR** Plaque gaz lisse, plaque cm.75,5x55 - 2 zones de cuisson • **ES** Fry-top gas liso, plancha cm.75,5x55 - 2 zonas de cocción  
**cm. 80x 65x 29h**



14 kW  
12.040 kcal/h

**2.624,00**  
84 / 0,35



MOD. \_\_\_\_\_  
COD. \_\_\_\_\_

DESCRIZIONE/DESCRIPTION/BEZEICHNUNG/DESCRIPTION/DESCRIPCIÓN  
DIMENSIONI/DIMENSIONS/ABMESSUNGEN/DIMENSIONS/DIMENSIONES

POTENZA/POWER/LEISTUNG/PUISSANCE/POTENCIA  
VOLTAGGIO/VOLTAGE/SPANNUNG/VOLTAGE/VOLTAJE

14 kW  
12.040 kcal/h

PREZZO/PRICE €  
PREIS/PRIX/PRECIO €  
KG / M<sup>3</sup>

**FTL-8GS**  
07230854

**FRY-TOP GAS LISCIO CROMATO, PIASTRA CM.75,5X55 - 2 ZONE DI COTTURA**  
EN Gas Fry-top smooth chromed griddle, plate cm.75,5x55 - 2 cooking areas • DE Gas-griddleplatte glatt hartverchromt, platte cm.75,5x55 - 2 Heizzonen • FR Plaque gaz lisse chromée, plaque cm.75,5x55 - 2 zones de cuisson • ES Fry-top gas liso cromado, plancha cm.75,5x55 - 2 zonas de cocción  
**cm. 80x 65x 29h**

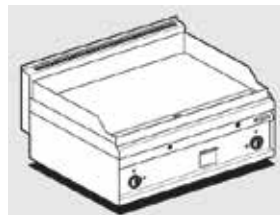

14 kW  
12.040 kcal/h

**3.339,00**  
84 / 0,35

**FTLR-8G**  
07230852

**FRY-TOP GAS 1/2 RIGATO + 1/2 LISCIO, PIASTRA CM.75,5X55 - 2 ZONE DI COTTURA**  
EN Gas Fry-top 1/2 grooved + 1/2 smooth, plate cm.75,5x55 - 2 cooking areas • DE Gas-griddleplatte 1/2 gerillt + 1/2 glatt, platte cm.75,5x55 - 2 Heizzonen • FR Plaque gaz 1/2 nervurée + 1/2 lisse, plaque cm.75,5x55 - 2 zones de cuisson • ES Fry-top gas 1/2 estriado + 1/2 liso, plancha cm.75,5x55 - 2 zonas de cocción  
**cm. 80x 65x 29h**

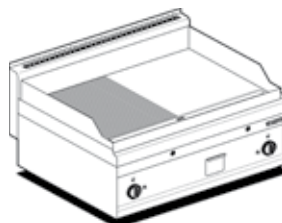

14 kW  
12.040 kcal/h

**2.770,00**  
84 / 0,35

**FTLR-8GS**  
07230855

**FRY-TOP GAS 1/2 RIGATO + 1/2 LISCIO CROMATO, PIASTRA CM.75,5X55 - 2 ZONE DI COTTURA**  
EN Gas Fry-top 1/2 grooved + 1/2 smooth chromed griddle, plate cm.75,5x55 - 2 cooking areas • DE Gas-griddleplatte 1/2 gerillt + 1/2 glatt hartverchromt, platte cm.75,5x55 - 2 Heizzonen • FR Plaque gaz 1/2 nervurée + 1/2 lisse chromée, plaque cm.75,5x55 - 2 zones de cuisson • ES Fry-top gas 1/2 estriado + 1/2 liso cromado, plancha cm.75,5x55 - 2 zonas de cocción  
**cm. 80x 65x 29h**



14 kW  
12.040 kcal/h

**3.503,00**  
84 / 0,35

**PL-4**  
07010400

**PIANO LAVORO CASSETTO CON 1 BACINELLA GN 1/1 15H PLASTICA.**  
EN Worktop - Drawer with 1 plastic container GN 1/1 15h • DE Arbeitsplatte - Schublade mit 1 GN 1/1 15h Kunststoffbehälter • FR Plan de travail - Tiroir avec bac en plastique GN 1/1 15h • ES Sobre de trabajo - Cajón con 1 contenedor GN 1/1 15h plástico  
**cm. 40x 65x 29h**

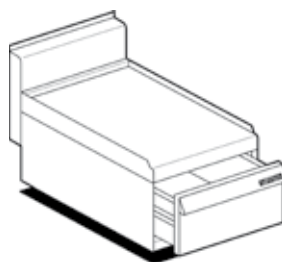

**585,00**  
25 / 0,18

**PL-6**  
07010600

**PIANO LAVORO - CASSETTO CON 2 BACINELLE: 1 GN 1/1 15H PLASTICA, 1 CM. 17X46,5X15H INOX.**  
EN Worktop - Drawer with 2 containers: 1 GN 1/1 15h plastic, 1 cm. 17x46,5x15h inox. • DE Arbeitsplatte - Schublade mit 2 Behältern: 1 GN 1/1 15h aus Kunststoff, 1 cm. 17x46,5x15h aus Edelstahl. • FR Plan de travail - Tiroir avec 2 bacs: 1 GN 1/1 en plastique, 1 cm. 17x46,5x15h en acier inoxydable • ES Sobre de trabajo - Cajón con 2 contenedores: 1 GN 1/1 15h plástico, 1 cm. 17x46,5x15h inox  
**cm. 60x 65x 29h**



**668,00**  
34 / 0,27

**PL-8**  
07010800

**PIANO LAVORO CASSETTO CON 2 BACINELLE GN 1/1 15H PLASTICA.**  
EN Worktop - Drawer with 2 plastic containers GN 1/1 15h • DE Arbeitsplatte - Schublade mit 2 GN 1/1 15h Kunststoffbehältern • FR Plan de travail - Tiroir avec 2 bacs en plastique GN 1/1 15h • ES Sobre de trabajo - Cajón con 2 contenedores GN 1/1 15h plástico  
**cm. 80x 65x 29h**

**783,00**  
40 / 0,35



MOD. \_\_\_\_\_  
COD. \_\_\_\_\_

DESCRIZIONE/DESCRIPTION/BEZEICHNUNG/DESCRIPTION/DESCRIPCIÓN  
DIMENSIONI/DIMENSIONS/ABMESSUNGEN/DIMENSIONS/DIMENSIONES

POTENZA/POWER/LEISTUNG/PUISSANCE/POTENCIA  
VOLTAGGIO/VOLTAGE/SPANNUNG/VOLTAGE/VOLTAJE

⚡ kW kcal/h  
⚡ kw V~ Hz

PREZZO/PRICE €  
PREIS/PRIX/PRECIO €  
KG / M<sup>3</sup>

**PL-10**  
07011000

**PIANO LAVORO 2 CASSETTI CON 3 BACINELLE: 2 GN 1/1 H15 PLASTICA, 1 CM. 17X46,5X15H INOX.**

**EN** Worktop - 2 drawers with 3 containers: 2 GN 1/1 h15 plastic, 1 cm. 17x46,5x15h inox. • **DE** Arbeitsplatte - 2 Schubladen mit 3 Behältern: 2 GN 1/1 h15 aus Kunststoff, 1 cm. 17x46,5x15h aus Edelstahl. • **FR** Plan de travail - 2 tiroirs avec 3 bacs: 2 GN 1/1 15 h en plastique, 1 cm. 17x46,5x15h en inox • **ES** Sobre de trabajo - 2 cajones con 3 contenedores: 2 GN 1/1 15h plástico, 1 cm. 17x46,5x15h inox  
**cm. 100x 65x 29h**



**919,00**  
53.5 / 0,43

**APL-85**  
07428500

**ANGOLO PIANO LAVORO**

**EN** Corner base with door • **DE** Eckschrank mit Tür  
• **FR** Placard d'angle avec porte • **ES** Ángulo sobre de trabajo  
**cm.85x85x 65x 87h**



**1.382,00**  
58 / 1,06

**LA-6**  
07020600

**LAVELLO RUBINETTO A LEVA - VASCA CM. 40X40X15H**

**EN** Sink unit - Lever type tap - Bowl cm. 40x40x15h  
• **DE** Spülbecken - Einhebel-Mischbatterie Becken cm. 40x40x15h • **FR** Bac-évier avec robinetterie - Bac cm. 40x40x15h • **ES** Fregadero - Grifo a palanca - Pileta cm. 40x40x15h  
**cm. 60x 65x 29h**



**826,00**  
25 / 0,27

**LA-12 DX**  
07021200

**LAVELLO VASCA CM. 50X40X15H DX - SGOCCIOLATOIO CM. 60 SX RUBINETTO A LEVA A NORMA - CASSETTO CON 2 BACINELLE: 1 GN 1/1 H15 PLASTICA, 1 CM. 17X46,5X15H INOX**

**EN** Sink unit - R/h Bowl cm. 50x40x15h - L/h Draining board cm. 60. Lever type tap. Drawer with 2 containers: 1 GN 1/1 h15 plastic, 1 cm. 17x46,5x15h inox  
• **DE** Spülbecken - Becken cm. 50x40x15h rechts - Abtropffläche cm. 60 links - Einhebel-Mischbatterie  
Schublade mit 2 Behältern: 1 GN 1/1 h15 aus Kunststoff, 1 cm. 17x46,5x15h aus Edelstahl • **FR** Plan évier - Bac à droite cm 50x40x15h - Égouttoir à gauche cm 60 - Robinetterie - Tiroir avec 2 bacs: 1 GN 1/1 h15 en plastique, 1 cm. 17x46,5x15h en inox • **ES** Fregadero - Pileta cm 50x40x15h derecho - Escurridor 60 cm izq. - Grifo a palanca según normativa - Cajón con 2 contenedores: 1 GN 1/1 h15 plástico, 1 cm. 17x46,5x15h inox  
**cm. 120x 65x 29h**



**1.419,00**  
49.5 / 0,52

MOD. \_\_\_\_\_  
COD. \_\_\_\_\_

DESCRIZIONE/DESCRIPTION/BEZEICHNUNG/DESCRIPTION/DESCRIPCIÓN  
DIMENSIONI/DIMENSIONS/ABMESSUNGEN/DIMENSIONS/DIMENSIONES

POTENZA/POWER/LEISTUNG/PUISSANCE/POTENCIA  
VOLTAGGIO/VOLTAGE/SPANNUNG/VOLTAGE/VOLTAJE

⚡ kW kcal/h  
⚡ kW V~ Hz

PREZZO/PRICE €  
PREIS/PRIX/PRECIO €  
KG / M<sup>3</sup>

**LA-12 SX**  
07021201

**LAVELLO VASCA CM. 50X40X15H SX - SGOCCIOLATOIO CM. 60 DX. RUBINETTO A LEVA A NORMA - CASSETTO CON 2 BACINELLE: 1 GN 1/1 H15 PLASTICA, 1 CM. 17X46,5X15H INOX.**

**EN** Sink unit - L/h Bowl cm. 50x40x15h - R/h Draining board cm. 60. Lever type tap. Drawer with 2 containers: 1 GN 1/1 h15 plastic, 1 cm. 17x46,5x15h inox • **DE** Spülbecken - Becken cm. 50x40x15h links-Abtropffläche cm. 60 rechts - Einhebel-Mischbatterie Schublade mit 2 Behältern: 1 GN 1/1 h15 aus Kunststoff, 1 cm. 17x46,5x15h aus Edelstahl • **FR** Plan evier - Bac à gauche cm 50x40x15h - Égouttoir à droite cm 60. Robinetterie. Tiroir avec 2 bacs: 1 GN 1/1 h15 en plastique, 1 cm. 17x46,5x15h en inox • **ES** Fregadero - Pileta cm 50x40x15h izq. - Escurridor 60 cm derecho - Grifo a palanca según normativa - Cajón con 2 contenedores: 1 GN 1/1 h15 plástico, 1 cm. 17x46,5x15h inox

**cm. 120x 65x 29h**



**1.419,00**  
49.5 / 0,52

**LL-12 DX**  
07021210

**LAVELLO PREDISPOSTO - VASCA CM. 50X40X15H DX SGOCCIOLATOIO CM. 60 SX - RUBINETTO A LEVA A NORME.**

**EN** Sink unit - R/h Bowl cm. 50x40x15h - L/h Draining board cm. 60 - Suitable for dishwasher - Lever type tap. • **DE** Spülbecken - Becken cm. 50x40x15h rechts Abtropffläche cm. 60 links - Vorbereitung für Geschirrspülmaschine - Einhebel-Mischbatterie • **FR** Plan evier - Bac à droite cm 50x40x15h - Égouttoir à gauche cm 60 - Prêdisposé pour lave-vaisselle Robinetterie • **ES** Fregadero predispuesto - Pileta cm50x40x15h derecho Escurridor 60 cm. izq. - Grifo a palanca según normativa

**cm. 120x 65x 29h**



**1.261,00**  
34 / 0,52

**LL-12 SX**  
07021211

**LAVELLO PREDISPOSTO - VASCA CM. 50X40X15H SX SGOCCIOLATOIO CM. 60 DX - RUBINETTO A LEVA A NORME.**

**EN** Sink unit - L/h Bowl cm. 50x40x15h - R/h Draining board cm. 60 - Suitable for dishwasher - Lever type tap. • **DE** Geschirrspülmaschine - Einhebel-Mischbatterie. • **FR** Plan evier - Bac à gauche cm 50x40x15h - Égouttoir à droite cm 60 - Prêdisposé pour lave-vaisselle - Robinetterie • **ES** Fregadero predispuesto - Pileta cm50x40x15h izq. Escurridor 60 cm. derecho - Grifo a palanca según normativa

**cm. 120x 65x 29h**



**1.261,00**  
34 / 0,52

**ALA-85**  
07428501

**ANGOLO LAVELLO VASCA CM. 50X40X15H RUBINETTO A LEVA A NORMA.**

**EN** Corner base with sink and door Bowl cm. 50x40x15h - Lever tap • **DE** Eckschrank mit Spülbecken und Tür Becken cm. 50x40x15h - Einhebel-Mischbatterie • **FR** Placard d'angle avec evier et porte - Bac cm. 50x40x15h Groupe robinet à levier, aux normes hygiénique • **ES** Angulo fregadero - Cuba cm. 50x40x15h Grifo a palanca según normativa

**cm.85÷85x 65x 87h**



**1.868,00**  
55 / 1,06

**M-4**  
07420400

**MOBILE BASE A GIORNO**

**EN** Open stand • **DE** Unterschrank offen • **FR** Placard ouvert • **ES** Mueble base abierto

**cm. 40x 53,5x 58h**



**383,00**  
15 / 0,16

MOD. \_\_\_\_\_  
COD. \_\_\_\_\_

DESCRIZIONE/DESCRIPTION/BEZEICHNUNG/DESCRIPTION/DESCRIPCIÓN  
DIMENSIONI/DIMENSIONS/ABMESSUNGEN/DIMENSIONS/DIMENSIONES

POTENZA/POWER/LEISTUNG/PUISSANCE/POTENCIA  
VOLTAGGIO/VOLTAGE/SPANNUNG/VOLTAGE/VOLTAJE

⚡ kW kcal/h  
⚡ kw V~ Hz

PREZZO/PRICE €  
PREIS/PRIX/PRECIO €  
KG / M<sup>3</sup>

**MP-4**  
07420401

**BASE CON PORTA**  
**EN** Stand with door • **DE** Unterbau mit Flügeltüren  
• **FR** Placard avec porte • **ES** Base con puerta  
**cm. 40x 56,5x 58h**



**524,00**  
18 / 0,16

**MC-4**  
07420420

**BASE CON CASSETTI N. 2 CASSETTI - CON 2 BACINELLE GN 1/1 IN PLASTICA**  
**EN** Stand with drawers N. 2 drawers with 2 plastic GN 1/1 containers • **DE** Unterschrank mit Schubladen N. 2 Schubladen mit 2 GN 1/1 Kunststoffbehältern • **FR** Placard avec tiroirs N. 2 tiroirs avec 2 bacs GN 1/1 en plastique • **ES** Base con cajones N. 2 cajones con 2 contenedores GN 1/1 de plástico  
**cm. 40x 56,5x 58h**



**833,00**  
28.5 / 0,16

**M-6**  
07420600

**MOBILE BASE A GIORNO**  
**EN** Open stand • **DE** Unterschrank offen • **FR** Placard ouvert • **ES** Mueble base abierto  
**cm. 60x 53,5x 58h**



**536,00**  
19 / 0,24

**MP-6**  
07420602

**BASE CON PORTE**  
**EN** Stand with doors • **DE** Unterbau mit Flügeltüren  
• **FR** Placard avec portes • **ES** Base con puertas  
**cm. 60x 56,5x 58h**

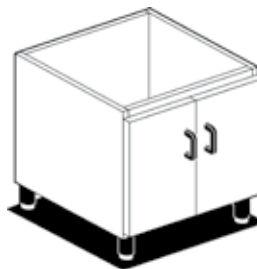

**698,00**  
23.5 / 0,24

**MC-6**  
07420620

**BASE CON CASSETTI - N. 2 CASSETTI CON 4 BACINELLE: N. 2 GN 1/1 15H IN PLASTICA + N. 2 CM. 17X46,5X15H INOX**  
**EN** Stand with drawers - N. 2 drawers with 4 containers: N. 2 GN 1/1 15h plastic containers + N. 2 cm. 17x46,5x15h s/s containers • **DE** Unterschrank mit Schubladen - N. 2 Schubladen mit 4 Behältern: N. 2 GN 1/1 15h Kunststoffbehälter + N. 2 cm. 17x46,5x15h Edelstahl-Behältern • **FR** Placard avec tiroirs - N. 2 tiroirs avec 4 bacs: N. 2 GN 1/1 15h en plastique + N. 2 cm. 17x46,5x15h en acier inoxydable • **ES** Base con cajones - N. 2 cajones con 4 contenedores: N. 2 GN 1/1 15h en plástico + N. 2 cm. 17x46,5x15h inox  
**cm. 60x 56,5x 58h**

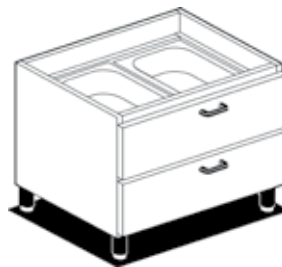

**867,00**  
37.5 / 0,24

**M-8**  
07420800

**MOBILE BASE A GIORNO**  
**EN** Open stand • **DE** Unterschrank offen • **FR** Placard ouvert • **ES** Mueble base abierto  
**cm. 80x 53,5x 58h**



**608,00**  
22 / 0,31

MOD. \_\_\_\_\_  
COD. \_\_\_\_\_

DESCRIZIONE/DESCRIPTION/BEZEICHNUNG/DESCRIPTION/DESCRIPCIÓN  
DIMENSIONI/DIMENSIONS/ABMESSUNGEN/DIMENSIONS/DIMENSIONES

POTENZA/POWER/LEISTUNG/PUISSANCE/POTENCIA  
VOLTAGGIO/VOLTAGE/SPANNUNG/VOLTAGE/VOLTAJE

⚡ kW kcal/h  
⚡ kw V~ Hz

PREZZO/PRICE €  
PREIS/PRIX/PRECIO €  
KG / M<sup>3</sup>

**MP-8**  
07420802

**BASE CON PORTE**  
**EN** Stand with doors • **DE** Unterbau mit Flügeltüren  
• **FR** Placard avec portes • **ES** Base con puertas  
**cm. 80x 56,5x 58h**

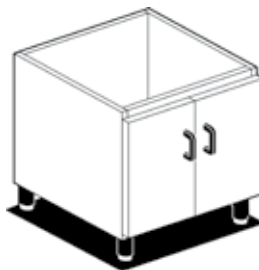

**773,00**  
28 / 0,31

**MC-8**  
07420820

**BASE CON CASSETTI N. 2 CASSETTI CON 4 BACINELLE GN 1/1 15H IN PLASTICA**  
**EN** Stand with drawers N. 2 drawers with 4 GN 1/1 15h containers • **DE** Unterschrank mit Schubladen N. 2 Schubladen mit 4 GN 1/1 15h Kunststoffbehälter • **FR** Placard avec tiroirs N. 2 tiroirs avec 4 bacs GN 1/1 15h en plastique • **ES** Base con cajones N. 2 cajones con 4 contenedores GN 1/1 15h en plástico  
**cm. 80x 56,5x 58h**

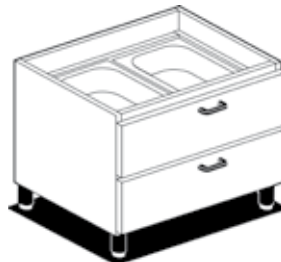

**1.200,00**  
41.5 / 0,31

**MCP-8**  
07420821

**BASE CON CASSETTI E PORTA - N. 2 CASSETTI CON 2 BACINELLE GN 1/1 15H IN PLASTICA**  
**EN** Stand with drawers and door N. 2 drawers with 2 GN 1/1 15h plastic containers • **DE** Unterschrank dreiseitig geschlossen mit 1 Flügeltür, N. 2 Schubladen mit 2 GN 1/1 15h Kunststoffbehältern • **FR** Placard avec tiroirs et portes - N. 2 tiroirs avec 2 bacs GN 1/1 15h en plastique • **ES** Base con cajones y puerta - N. 2 cajones con 2 contenedores GN 1/1 15h plástico  
**cm. 80x 56,5x 58h**



**1.200,00**  
40 / 0,31

**M-10**  
07421000

**MOBILE BASE A GIORNO**  
**EN** Open stand • **DE** Unterschrank offen • **FR** Placard ouvert • **ES** Mueble base abierto  
**cm. 100x 53,5x 58h**



**877,00**  
27 / 0,39

**MP-10**  
07421003

**BASE CON PORTE**  
**EN** Stand with doors • **DE** Unterbau mit Flügeltüren  
• **FR** Placard avec portes • **ES** Base con puertas  
**cm. 100x 56,5x 58h**

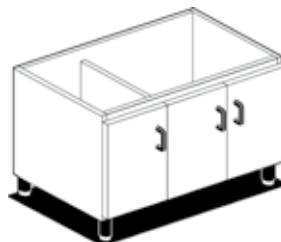

**1.180,00**  
35 / 0,39

**MCP-10**  
07421022

**BASE CON CASSETTI E PORTA N. 2 CASSETTI CON 2 BACINELLE GN 1/1 15H IN PLASTICA**  
**EN** Stand with drawers and door N. 2 drawers with 2 GN 1/1 15h plastic containers • **DE** Unterschrank dreiseitig geschlossen mit 1 Flügeltür, N. 2 Schubladen mit 2 GN 1/1 15h Kunststoffbehältern • **FR** Placard avec tiroirs et portes - N. 2 tiroirs avec 2 bacs GN 1/1 15h en plastique • **ES** Base con cajones y puerta - N. 2 cajones con 2 contenedores GN 1/1 15h plástico  
**cm. 100x 56,5x 58h**

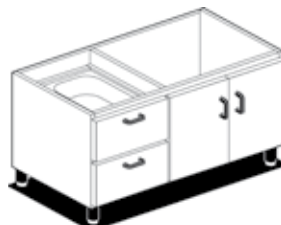

**1.499,00**  
45.5 / 0,39

MOD. \_\_\_\_\_  
COD. \_\_\_\_\_

DESCRIZIONE/DESCRIPTION/BEZEICHNUNG/DESCRIPTION/DESCRIPCIÓN  
DIMENSIONI/DIMENSIONS/ABMESSUNGEN/DIMENSIONS/DIMENSIONES

POTENZA/POWER/LEISTUNG/PUISSANCE/POTENCIA  
VOLTAGGIO/VOLTAGE/SPANNUNG/VOLTAGE/VOLTAJE

⚡ kW kcal/h  
⚡ kw V~ Hz

PREZZO/PRICE €  
PREIS/PRIX/PRECIO €  
KG / M<sup>3</sup>

**M-12**  
07421200

**MOBILE BASE A GIORNO**  
EN Open stand • DE Unterschrank offen • FR Placard ouvert • ES Mueble base abierto  
cm. 120x 53,5x 58h



**1.089,00**  
31 / 0,47

**MP-12**  
07421203

**BASE CON PORTE**  
EN Stand with doors • DE Unterbau mit Flügeltüren • FR Placard avec portes • ES Base con puertas  
cm. 120x 56,5x 58h

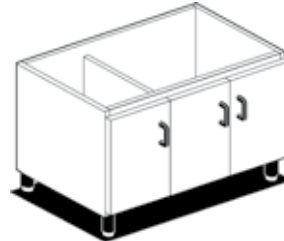

**1.574,00**  
40.5 / 0,47

**MCP-12**  
07421222

**BASE CON CASSETTI E PORTA N. 2 CASSETTI CON 2 BACINELLE GN 1/1 15H IN PLASTICA**  
EN Stand with drawers and door N. 2 drawers with 2 GN 1/1 15h plastic containers • DE Unterschrank dreiseitig geschlossen mit 1 Flügeltür, N. 2 Schubladen mit 2 GN 1/1 15h Kunststoffbehältern • FR Placard avec tiroirs et portes - N. 2 tiroirs avec 2 bacs GN 1/1 15h en plastique • ES Base con cajones y puerta - N. 2 cajones con 2 contenedores GN 1/1 15h plástico  
cm. 120x 56,5x 58h

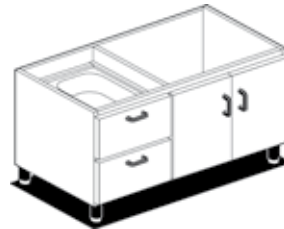

**1.613,00**  
51 / 0,47

**MPS-12**  
07421232

**BASE CON PORTE SCORREVOLI**  
EN Stand with sliding doors • DE Unterschrank mit Schiebetüren • FR Placard avec portes coulissantes • ES Base con puertas corredizas  
cm. 120x 56,5x 58h

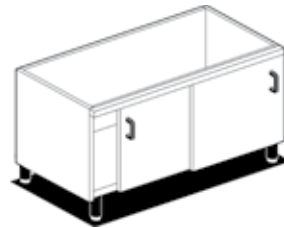

**1.318,00**  
43 / 0,47

**MPS-16**  
07421632

cm. 160x 56,5x 58h

**1.490,00**  
60 / 0,73

**MPS-20**  
07422032

cm. 200x 56,5x 58h

**1.688,00**  
67 / 0,91

**S-4**  
07410400

**CAVALLETTO BASE**  
EN Stand • DE Untergestell • FR Pietement simple • ES Soporte base  
cm. 40x 53,5x 58h

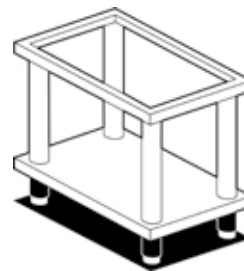

**359,00**  
19.5 / 0,16

**S-6**  
07410600

cm. 60x 53,5x 58h

**402,00**  
23 / 0,24

**S-8**  
07410800

cm. 80x 53,5x 58h

**473,00**  
26 / 0,31

**S-10**  
07411000

cm. 100x 53,5x 58h

**540,00**  
29 / 0,39





MOD. \_\_\_\_\_  
COD. \_\_\_\_\_

DESCRIZIONE/DESCRIPTION/BEZEICHNUNG/DESCRIPTION/DESCRIPCIÓN  
DIMENSIONI/DIMENSIONS/ABMESSUNGEN/DIMENSIONS/DIMENSIONES

POTENZA/POWER/LEISTUNG/PUISSANCE/POTENCIA  
VOLTAGGIO/VOLTAGE/SPANNUNG/VOLTAGE/VOLTAJE

⚡ kW kcal/h  
⚡ kw V~ Hz

PREZZO/PRICE €  
PREIS/PRIX/PRECIO €  
KG / M<sup>3</sup>

**PM-3DX**  
07430300

**PORTA 300 DX**  
EN R/h door 300 • DE Flügeltür 300 rechts • FR Porte droite 300 • ES Puerta 300 derecha  
**cm. 29,5x 2,5x 45h**



**161,00**  
2.5 / 0,01

**PM-4DX**  
07430400

**PORTA 400 DX**  
EN R/h door 400 • DE Flügeltür 400 rechts • FR Porte droite 400 • ES Puerta 400 derecha  
**cm. 39,5x 2,5x 45h**



**169,00**  
3.5 / 0,02

**PM-3SX**  
07430301

**PORTA 300 SX**  
EN L/h door 300 • DE Flügeltür 300 links • FR Porte gauche 300 • ES Puerta 300 izq.  
**cm. 29,5x 2,5x 45h**



**161,00**  
2.5 / 0,01

**PM-4SX**  
07430401

**PORTA 400 SX**  
EN L/h door 400 • DE Flügeltür 400 links • FR Porte gauche 400 • ES Puerta 400 izq.  
**cm. 39,5x 2,5x 45h**



**169,00**  
3.5 / 0,02

**C-4**  
07440420

**CASSETTIERA 400 N. 2 CASSETTI CON 2 BACINELLE GN 1/1 15H IN PLASTICA, GUIDE TELESCOPICHE.**  
EN Drawer set 400 - N. 2 drawers with 2 GN 1/1 15h plastic containers, telescopic guides • DE Schubladen 400 - N. 2 Schubladen mit 2 GN 1/1 15h Kunststoffbehältern Telescopeinführungen • FR Tiroirs pour meuble de 400 - N. 2 tiroirs avec 2 bacs en plastique GN 1/1 15h guides télescopiques • ES Cajonera 400 - N. 2 cajones con 2 contenedores GN 1/1 15h de plástico, guías telescópicas.  
**cm. 39,5x 56x 45h**

**566,00**  
18 / 0,16

**C-6**  
07440620

**CASSETTIERA 600 - N. 2 CASSETTI CON 4 BACINELLE N. 2 GN 1/1 15H IN PLASTICA - N. 2 CM. 17X46,5X15H INOX - GUIDE TELESCOPICHE.**  
EN Drawer set 600 - N. 2 drawers with 4 containers N. 2 GN 1/1 15h in plastic - N. 2 cm. 17x46,5x45h inox - Telescopic guides. • DE Schubladen 600 - N. 2 Schubladen mit 4 Behältern N. 2 GN 1/1 15h aus Kunststoff - N. 2 cm. 17x46,5x45h aus Edelstahl - Telescopeinführungen • FR Tiroirs pour meuble de 600 - N. 2 tiroirs avec 4 bacs: N. 2 GN 1/1 15h en plastique, N. 2 cm. 17x46,5x45h en acier inoxydable, guides télescopiques. • ES Cajonera 600 - N. 2 cajones con 4 contenedores, N. 2 GN 1/1 15h de plástico, N. 2 cm 17x46,5x45h inox, guías telescópicas.  
**cm. 59,5x 56x 45h**

**672,00**  
24 / 0,24

**C-8**  
07440820

**CASSETTIERA 800 N. 2 CASSETTI CON 4 BACINELLE GN 1/1 15H IN PLASTICA, GUIDE TELESCOPICHE.**  
EN Drawer set 800 - N. 2 drawers with 4 GN 1/1 15h plastic containers, telescopic guides • DE Schubladen 800 - N. 2 Schubladen mit 4 GN 1/1 15h Kunststoffbehältern Telescopeinführungen • FR Tiroirs pour meuble de 800 - N. 2 tiroirs avec 4 bacs en plastique GN 1/1 15h guides télescopiques • ES Cajonera 800 - N. 2 cajones con 4 contenedores GN 1/1 15h de plástico, guías telescópicas.  
**cm. 79,5x 56x 45h**

**883,00**  
26 / 0,31

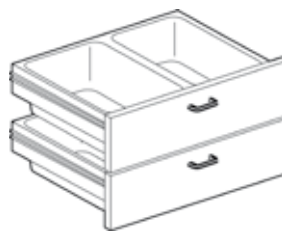

# ACCESSORI

MOD. COD.	DESCRIZIONE/DESCRIPTION/BEZEICHNUNG/DESCRIPTION/DESCRIPCIÓN DIMENSIONI/DIMENSIONS/ABMESSUNGEN/DIMENSIONS/DIMENSIONES	POTENZA/POWER/LEISTUNG/PUISSANCE/POTENCIA VOLTAGGIO/VOLTAGE/SPANNUNG/VOLTAGE/VOLTAJE	⚡ kW kcal/h	⚡ kW V~ Hz	PREZZO/PRICE € PREIS/PRIX/PRECIO € KG / M <sup>3</sup>
<b>R-4</b> 07450400	<b>RIPIANO 400</b> EN Shelf 400 • DE Abstellbrett 400 • FR Etagère 400 • ES Estante 400 cm. 35x 53x 2h				<b>101,00</b> 1.5 / 0,01
<b>R-6</b> 07450600	<b>RIPIANO 600</b> EN Shelf 600 • DE Abstellbrett 600 • FR Etagère 600 • ES Estante 600 cm. 55x 53x 2h				<b>113,00</b> 2 / 0,01
<b>R-8</b> 07450800	<b>RIPIANO 800</b> EN Shelf 800 • DE Abstellbrett 800 • FR Etagère 800 • ES Estante 800 cm. 75x 53x 2h				<b>128,00</b> 2.5 / 0,02
<b>544023800</b>	<b>RASCHIETTO PER PIASTRA RIGATA</b> EN Scraper for gooved plate • DE Schaber für gerillte Kochplatte • FR Racloir pour plaque nervurée • ES Rasqueta para placa ranurada				<b>50,00</b> / 1,00
<b>531040800</b>	<b>RASCHIETTO PER PIASTRA LISCIA CROMATA</b> EN Scraper for smooth chromed plate • DE Schaber für glatte verchromte Platte • FR Racloir pour plaque lisse au chrome • ES Rasqueta para placa lisa cromada				<b>47,00</b> / 1,00
<b>531040900</b>	<b>KIT 10 LAME PER RASCHIETTO</b> EN 10 blades kit for scraper • DE Kit 10 Klingen für Schaber • FR Kit de 10 lames pour racloir • ES Kit de 10 cuchillas para rasqueta				<b>33,00</b> / 0,00
<b>CG-65</b> 07560000	<b>COPRIGIUNTO</b> EN Joint cover • DE Klemmsteg • FR Couvre-joint • ES Cubre junta cm. 0,7x 58x 1,2h				<b>31,00</b> 0.1 / 0,00
<b>TG-4</b> 07580400	<b>TAGLIERE PLASTICA</b> EN Plastic chopping-board • DE Schneidebrett • FR Plan de découpe • ES Picador de plástico cm. 39x 58x 2,5h				<b>126,00</b> 6 / 0,01
<b>TG-6</b> 07580600	cm. 59x 58x 2,5h				<b>186,00</b> 9 / 0,02
<b>TG-8</b> 07580800	cm. 79x 58x 2,5h				<b>240,00</b> 11 / 0,02
<b>TG-10</b> 07581000	cm. 99x 58x 2,5h				<b>258,00</b> 14 / 0,02

# ACCESSORI BRASIERE

MOD. \_\_\_\_\_  
COD. \_\_\_\_\_

DESCRIZIONE/DESCRIPTION/BEZEICHNUNG/DESCRIPTION/DESCRIPCIÓN  
DIMENSIONI/DIMENSIONS/ABMESSUNGEN/DIMENSIONS/DIMENSIONES

POTENZA/POWER/LEISTUNG/PUISSANCE/POTENCIA  
VOLTAGGIO/VOLTAGE/SPANNUNG/VOLTAGE/VOLTAJE

⚡ kW kcal/h  
⚡ kw V~ Hz

PREZZO/PRICE €  
PREIS/PRIX/PRECIO €  
KG / M<sup>3</sup>

**06290600 COPERCHIO (BR-6)**  
EN Lid (BR-6) • DE Deckel (BR-6) • FR Couvercle (BR-6) • ES Tapa (BR-6)  
cm. 51x 42x 3h

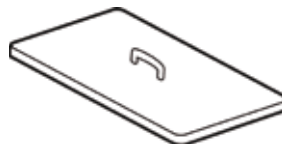

**110,00**  
3 / 0,02

**PLF 07590401 PIASTRA LISCIA PER GRIGLIA IN GHISA**  
EN Smooth griddle plate for cast iron grid • DE Fortkochplatte glatt für Gusseisen Rost • FR Plaque lisse pour la grille en fonte • ES Plancha lisa para rejilla de hierro fundido  
cm. 35x 27



**151,00**  
9 / 0,01

**PLF/2 07590421 PIASTRA LISCIA 2 FUOCHI PER GRIGLIA IN GHISA**  
EN Smooth griddle plate 2 burners for cast iron grid • DE Fortkochplatte glatt 2 Kochstellen für Gusseisen Rost • FR Plaque lisse 2 feux pour la grille en fonte • ES Plancha lisa 2 quemadores para rejilla de hierro fundido  
cm. 35x 57



**299,00**  
18 / 0,01

**PRF 07590403 PIASTRA RIGATA PER GRIGLIA IN GHISA**  
EN Grooved griddle plate for cast iron grid • DE Fortkochplatte gerillt für Gusseisen Rost • FR Plaque nervurée pour la grille en fonte • ES Plancha estriada para rejilla de hierro fundido  
cm. 35x 27

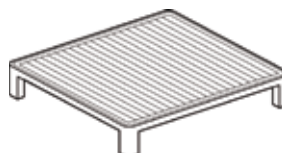

**203,00**  
9 / 0,01

**PRF/2 07590423 PIASTRA RIGATA 2 FUOCHI PER GRIGLIA IN GHISA**  
EN Grooved griddle plate 2 burners for cast iron grid • DE Fortkochplatte gerillt 2 Kochstellen für Gusseisen Rost • FR Plaque nervurée 2 feux pour la grille en fonte • ES Plancha estriada 2 quemadores para rejilla de hierro fundido  
cm. 35x 57



**332,00**  
18 / 0,01

**533009200 GRIGLIA DI RIDUZIONE**  
EN Reduction • DE Reduzierstern • FR Grille de réduction • ES Rejilla de reducción  
cm. 25x 25



**31,00**  
0,2 / 0,00

**544439900 ANELLO PER WOK - SOLO PER GRIGLIE IN GHISA**  
EN Wok ring - only for cast iron grills • DE Wok Aufsatzring - nur für Roste aus Gusseisen • FR Anneau Wok - seulement pour grilles en fonte • ES Anillo Wok - solo para parrillas de hierro colado  
cm. Ø 22,5x 3,5h

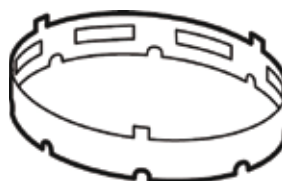

**126,00**  
2 / 0,00

**D-8 07470000 DIVISORIO NECESSARIO PER APPLICARE CASSETTIERA C-4 SU MOBILE M-8**  
EN Partition - for installation of a C-4 on a stand M-8 • DE Trennwand - Um ein C-4 an einem Unterschrank M-8 einzubauen • FR Separation - Pour l'installation de C-4 sur placard M-8 • ES Divisorio - Necesario para aplicar cajoneras C-4 en mueble M-8  
cm. 5x 53,5x 38,5h

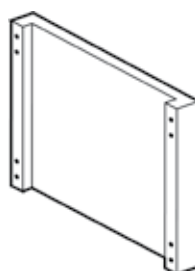

**128,00**  
2 / 0,02



Le immagini presentate non sono vincolanti. La ditta si riserva di apportare modifiche senza preavviso. • The pictures are purely representative. The manufacturer reserves the right to modify the technical data and models without previous notice. • Les images

LO

présentées ne nous engagent pas. La Société se réserve le droit d'apporter tout modification sans préavis. • Die dargestellten Abbildungen sind nicht verbindlich. Technische Änderungen vorbehalten. • Las imágenes presentadas no son vinculantes. El Fabricante se reserva el derecho de modificar sus productos sin previo aviso.

01/20

111

MOD. \_\_\_\_\_  
COD. \_\_\_\_\_

DESCRIZIONE/DESCRIPTION/BEZEICHNUNG/DESCRIPTION/DESCRIPCIÓN  
DIMENSIONI/DIMENSIONS/ABMESSUNGEN/DIMENSIONS/DIMENSIONES

POTENZA/POWER/LEISTUNG/PUISSANCE/POTENCIA  
VOLTAGGIO/VOLTAGE/SPANNUNG/VOLTAGE/VOLTAJE

⚡ kW kcal/h  
⚡ kw V~ Hz

PREZZO/PRICE €  
PREIS/PRIX/PRECIO €  
KG / M<sup>3</sup>

PT  
07460002

**PORTATEGLIE VANO 400/600 (GN-1/1) 4  
RIPIANI INT. 9 CM.**

**EN** Frame for plates 400/600 (GN-1/1) - N. 4 shelves, wheel-base 9 cm. • **DE** Auflangeschienen für bleche 400/600 (GN-1/1) N. 4 Etagen, Abstand 9 cm. • **FR** Kit porte-plaques 400/600 (GN-1/1) - N. 4 étagères; 9 cm. • **ES** Portacazuelas 400/600 (GN-1/1) - N. 4 estantes, int. 9 cm.

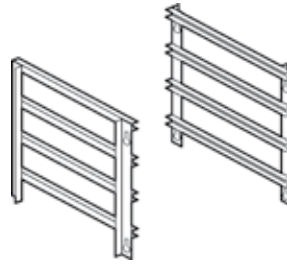

**365,00**  
2 / 0,01

07570400

**GRIGLIA PER CARNI GRASSE REGOLABILE  
(CW-4)**

**EN** Adjustable grill for meat (CW-4) • **DE** Einstellbarer Fleischrost (CW-4) • **FR** Grille cannelée à gorges, réglable (CW-4) • **ES** Parrilla para carnes grasas regulable (CW-4)  
**cm. 38x 47**



**199,00**  
2.5 / 0,03

06300600

**GRIGLIA PER CARNI GRASSE REGOLABILE  
(CW-6)**

**EN** Adjustable grill for meat (CW-6) • **DE** Einstellbare Fleischrost (CW-6) • **FR** Grille cannelée réglable à gorges (CW-6) • **ES** Parrilla para carnes grasas regulable (CW-6)  
**cm. 28x 47**

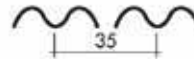

**193,00**  
2 / 0,02

531048000

**CESTO 1/6 PER CPM-6G**

**EN** Basket 1/6 for CPM-6G • **DE** Korb 1/6 für CPM-6G • **FR** Panier 1/6 pour CPM-6G • **ES** Cesta 1/6 para CPM-6G  
**cm. 13,5x 16x 21,5h**



**75,00**  
1 / 0,02

531064300

**CESTO 1/4 PER CPM-6G**

**EN** Basket 1/4 for CPM-6G • **DE** Korb 1/4 für CPM-6G • **FR** Panier 1/4 pour CPM-6G • **ES** Cesta 1/4 para CPM-6G  
**cm. 11,5x 29x 20h**

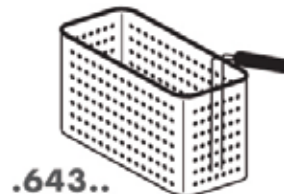

**95,00**  
1,2 / 0,04

531018700

**CESTO CON GANCIO 1/4 PER CPM-6G**

**EN** Basket with hook 1/4 for CPM-6G • **DE** Korb mit Haken 1/4 für CPM-6G • **FR** Panier avec crochet 1/4 pour CPM-6G • **ES** Cesta con gancho 1/4 para CPM-6G  
**cm. 11x 26x 20h**



**96,00**  
1,2 / 0,04

531069500

**SUPPORTO PER CESTI CON GANCIO PER CPM-6G**

**EN** support for baskets with hook for CPM-6G • **DE** Unterstützung für Körbe mit Haken für CPM-6G • **FR** soutien pour les paniers avec crochet pour CPM-6G • **ES** soporte para cestas con gancho para CPM-6G  
**cm. 50x 29x 39h**



**145,00**  
4 / 0,08

# ACCESSORI FRIGGITRICI

MOD. \_\_\_\_\_  
COD. \_\_\_\_\_

DESCRIZIONE/DESCRIPTION/BEZEICHNUNG/DESCRIPTION/DESCRIPCIÓN  
DIMENSIONI/DIMENSIONS/ABMESSUNGEN/DIMENSIONS/DIMENSIONES

POTENZA/POWER/LEISTUNG/PUISSANCE/POTENCIA  
VOLTAGGIO/VOLTAGE/SPANNUNG/VOLTAGE/VOLTAJE

↓ kW kcal/h  
↗ kW  
V~ Hz

PREZZO/PRICE €  
PREIS/PRIX/PRECIO €  
KG / M<sup>3</sup>

**531043900 CESTO 1/1 (FP-6E)**  
EN basket 1/1 (FP-6E) • DE Fritierkorb 1/1 (FP-6E)  
• FR Panier 1/1 (FP-6E) • ES cesta 1/1 (FP-6E)  
cm. 46x 30x 10h



**126,00**  
3 / 0,06

**531024300 CESTO 1/1 (FP-6G)**  
EN basket 1/1 (FP-6G) • DE Fritierkorb 1/1 (FP-6G)  
• FR Panier 1/1 (FP-6G) • ES cesta 1/1 (FP-6G)  
cm. 42,5x 31x 10h



**124,00**  
3 / 0,06

**531013200 CESTO 1/2 (FQ-4-6) 1/4 (FP-6E)**  
EN basket 1/2 (FQ-4-6) 1/4 (FP-6E) • DE Fritierkorb  
1/2 (FQ-4-6) 1/4 (FP-6E) • FR Panier 1/2 (FQ-4-6)  
1/4 (FP-6E) • ES cesta 1/2 (FQ-4-6) 1/4 (FP-6E)  
cm. 10x 30x 12h



**47,00**  
0.7 / 0,03

**531013500 CESTO 1/2 (FQM-4G)**  
EN basket 1/2 (FQM-4G) • DE Fritierkorb 1/2  
(FQM-4G) • FR Panier 1/2 (FQM-4G) • ES cesta 1/2  
(FQM-4G)  
cm. 14x 33x 12h



**57,00**  
0.8 / 0,04

**06280600 SCIVOLO (FP-6E)**  
EN Slide (FP-6E) • DE Rutsche (FP-6E) • FR Goulotte  
(FP-6E) • ES Deslizador (FP-6E)  
cm. 60x 34

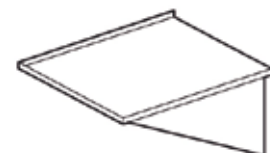

**115,00**  
4 / 0,05

**07600600 SCIVOLO (FP-6G)**  
EN Slide (FP-6G) • DE Rutsche (FP-6G) • FR Goulotte  
(FP-6G) • ES Deslizador (FP-6G)  
cm. 55x 34

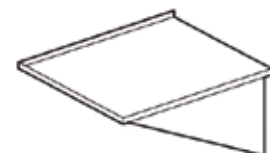

**113,00**  
4 / 0,05

**FU-1X7** **FORMA PER UOVA Ø 7**  
05281700 EN Egg poachers Ø 7 • DE Eierformer Ø 7 • FR  
Forme a oeuf Ø 7 • ES Molde para huevos Ø 7

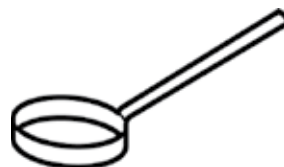

**16,00**  
1 / 0,00

**FU-1X9** **FORMA PER UOVA Ø 9**  
05281900 EN Egg poachers Ø 9 • DE Eierformer Ø 9 • FR  
Forme a oeuf Ø 9 • ES Molde para huevos Ø 9

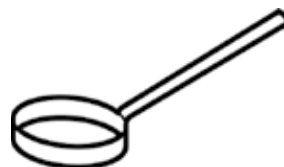

**20,00**  
1 / 0,00

**FU-2X7** **FORMA PER UOVA 2XØ 7**  
05282700 EN Egg poachers Ø 7 • DE Eierformer Ø 7 • FR  
Forme a oeuf Ø 7 • ES Molde para huevos Ø 7



**29,00**  
1.5 / 0,00

**FU-2X9** **FORMA PER UOVA 2XØ 9**  
05282900 EN Egg poachers Ø 9 • DE Eierformer Ø 9 • FR  
Forme a oeuf Ø 9 • ES Molde para huevos Ø 9



**31,00**  
1.5 / 0,00

**FU-3X7** **FORMA PER UOVA 3XØ 7**  
05283700 EN Egg poachers Ø 7 • DE Eierformer Ø 7 • FR  
Forme a oeuf Ø 7 • ES Molde para huevos Ø 7



**37,00**  
2 / 0,00

**FU-3X9** **FORMA PER UOVA 3XØ 9**  
05283900 EN Egg poachers Ø 9 • DE Eierformer Ø 9 • FR  
Forme a oeuf Ø 9 • ES Molde para huevos Ø 9



**40,00**  
2 / 0,00



Le immagini presentate non sono vincolanti. La ditta si riserva di apportare modifiche senza preavviso. • The pictures are purely representative. The manufacturer reserves the right to modify the technical data and models without previous notice. • Les images

LO

présentées ne nous engagent pas. La Société se réserve le droit d'apporter tout modification sans préavis. • Die dargestellten Abbildungen sind nicht verbindlich. Technische Änderungen vorbehalten. • Las imágenes presentadas no son vinculantes. El Fabricante se reserva el derecho de modificar sus productos sin previo aviso.

01/20

113





# SUPER LO 70



70



Le immagini presentate non sono vincolanti. La ditta si riserva di apportare modifiche senza preavviso. • The pictures are purely representative. The manufacturer reserves the right to modify the technical data and models without previous notice. • Les images

LO

présentées ne nous engagent pas. La Société se réserve le droit d'apporter toute modification sans préavis. • Die dargestellten Abbildungen sind nicht verbindlich. Technische Änderungen vorbehalten. • Las imágenes presentadas no son vinculantes. El Fabricante se reserva el derecho de modificar sus productos sin previo aviso.

01/20

115

MOD. \_\_\_\_\_  
COD. \_\_\_\_\_

DESCRIZIONE/DESCRIPTION/BEZEICHNUNG/DESCRIPTION/DESCRIPCIÓN  
DIMENSIONI/DIMENSIONS/ABMESSUNGEN/DIMENSIONS/DIMENSIONES

POTENZA/POWER/LEISTUNG/PUISSANCE/POTENCIA  
VOLTAGGIO/VOLTAGE/SPANNUNG/VOLTAGE/VOLTAJE

⚡ kW \_\_\_\_\_  
kcal/h \_\_\_\_\_  
V~ \_\_\_\_\_  
Hz \_\_\_\_\_

PREZZO/PRICE € \_\_\_\_\_  
PREIS/PRIX/PRECIO \_\_\_\_\_  
KG / M<sup>3</sup> \_\_\_\_\_

**CF4-78ET**  
08660830

**CUCINA 4 PIASTRE - FORNO ELETTRICO STATICO CM. 67X55X34H, TEMP: 50÷300°C, CON 1 GRIGLIA CM.65X53 GN2/1 (INCLUSA 1 TESTATA CHIUSURA PIANO MOD.TPA-7)**

**EN** Electric range - N. 4 plates Traditional electric oven cm. 67x55x34h, temp: 50÷300°C, with 1 grid cm.65x53 GN2/1 (included 1 Head end filler strip mod. TPA-7) • **DE** Elektroherd - N. 4 Kochplatten Statischer Elektro-Backofen cm. 67x55x34h, temp: 50÷300°C, mit 1 Rost cm.65x53 GN2/1 (inbegriffen 1 Abschluss-Element mod.TPA-7) • **FR** Fourneau électrique - N. 4 plaques Four électrique statique cm. 67x55x34h, temp: 50÷300°C avec 1 grille cm.65x53 GN2/1 (inclus 1 Élément de jonction top mod.TPA-7) • **ES** Cocina eléctrica - N. 4 planchas Horno eléctrico estático cm. 67x55x34h, temp: 50÷300°C, con 1 parilla cm.65x53 GN2/1 (incluida 1 Chapa de cierre para top mod. TPA-7)

**cm. 80x 70,5x 90h**



⚡ 15,4 kW \_\_\_\_\_ **2.872,00**  
400V~3N \_\_\_\_\_ 112 / 0,71  
50/60 Hz \_\_\_\_\_

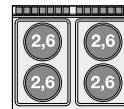

**CFV4-78ET**  
08660835

**CUCINA 4 PIASTRE - FORNO ELETTRICO VENTILATO CM. 55X36X34H, TEMP: 50÷300°C, CON 1 GRIGLIA CM.53X32,5 GN1/1 (INCLUSA 1 TESTATA CHIUSURA PIANO MOD.TPA-7)**

**EN** Electric range - N. 4 plates - electric fan oven cm. 55x36x34h, temp: 50÷300°C, with 1 grid cm.53x32,5 GN1/1 (included 1 Head end filler strip mod.TPA-7) • **DE** Elektroherd - N. 4 Kochplatten - Elektro-Heißluftofen cm. 55x36x34h, temp: 50÷300°C, mit 1 Rost cm.53x32,5 GN1/1 (inbegriffen 1 Abschluss-Element mod.TPA-7) • **FR** Fourneau électrique - N. 4 plaques Four à chaleur tournante électrique cm. 55x36x34h, temp: 50÷300°C avec 1 grille cm.53x32,5 GN1/1 (inclus 1 Élément de jonction top mod.TPA-7) • **ES** Cocina eléctrica - N. 4 planchas - Horno eléctrico ventilado cm. 55x36x34h, temp: 50÷300°C, con 1 parilla cm.53x32,5 GN1/1 (incluida 1 Chapa de cierre para top mod.TPA-7)

**cm. 80x 70,5x 90h**

⚡ 15,72 kW \_\_\_\_\_ **3.215,00**  
400V~3N \_\_\_\_\_ 112 / 0,71  
50/60 Hz \_\_\_\_\_

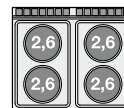

**CFQ4-78ET**  
08660831

**CUCINA 4 PIASTRE QUADRE - FORNO ELETTRICO STATICO CM. 67X55X34H, TEMP: 50÷300°C, CON 1 GRIGLIA CM.65X53 GN2/1 (INCLUSA 1 TESTATA CHIUSURA PIANO MOD. TPA-7)**

**EN** Electric range - N. 4 square plates Traditional electric oven cm. 67x55x34h, temp: 50÷300°C, with 1 grid cm.65x53 GN2/1 (included 1 Head end filler strip mod.TPA-7) • **DE** Elektroherd - N. 4 quadratischen Platten - Statischer Elektro-Backofen cm. 67x55x34h, temp: 50÷300°C, mit 1 Rost cm.65x53 GN2/1 (inbegriffen 1 Abschluss-Element mod.TPA-7) • **FR** Fourneau électrique - N. 4 plaques carrés - Four électrique statique cm. 67x55x34h, temp: 50÷300°C avec 1 grille cm.65x53 GN2/1 (inclus 1 Élément de jonction top mod.TPA-7) • **ES** Cocina eléctrica - N. 4 planchas cuadradas Horno eléctrico estático cm. 67x55x34h, temp: 50÷300°C, con 1 parilla cm.65x53 GN2/1 (incluida 1 Chapa de cierre para top mod. TPA-7)

**cm. 80x 70,5x 90h**



⚡ 15,4 kW \_\_\_\_\_ **3.712,00**  
400V~3N \_\_\_\_\_ 120 / 0,71  
50/60 Hz \_\_\_\_\_

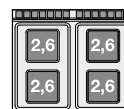

MOD. \_\_\_\_\_  
COD. \_\_\_\_\_

DESCRIZIONE/DESCRIPTION/BEZEICHNUNG/DESCRIPTION/DESCRIPCIÓN  
DIMENSIONI/DIMENSIONS/ABMESSUNGEN/DIMENSIONS/DIMENSIONES

POTENZA/POWER/LEISTUNG/PUISSANCE/POTENCIA  
VOLTAGGIO/VOLTAGE/SPANNUNG/VOLTAGE/VOLTAJE

⚡ kW  
400V~3N  
50/60 Hz

PREZZO/PRICE €  
PREIS/PRIX/PRECIO €  
KG / M<sup>3</sup>

**CFVQ4-78ET CUCINA 4 PIASTRE QUADRE - FORNO  
ELETTRICO VENTILATO CM. 55X36X34H,  
TEMP: 50÷300°C, CON 1 GRIGLIA  
CM.53X32,5 GN1/1 (INCLUSA 1 TESTATA  
CHIUSURA PIANO MOD.TPA-7)**

08660836

**EN** Electric range - N. 4 square plates - electric fan oven cm. 55x36x34h, temp: 50÷300°C, with 1 grid cm.53x32,5 GN1/1 (included 1 Head end filler strip mod.TPA-7) • **DE** Elektroherd - N. 4 quadratischen Platten - Elektro-Heißluftofen cm. 55x36x34h, temp: 50÷300°C, mit 1 Rost cm.53x32,5 GN1/1 (inbegriffen 1 Abschluss-Element mod.TPA-7) • **FR** Fourneau électrique - N. 4 plaques carrées - Four à chaleur tournante électrique cm. 55x36x34h, temp: 50÷300°C avec 1 grille cm.53x32,5 GN1/1 (inclus 1 Élément de jonction top mod.TPA-7) • **ES** Cocina eléctrica - N. 4 planchas cuadradas Horno eléctrico ventilado cm. 55x36x34h, temp: 50÷300°C, con 1 parilla cm.53x32,5 GN1/1 (incluida 1 Chapa de cierre para top mod.TPA-7)  
**cm. 80x 70,5x 90h**



⚡ 15,72 kW  
400V~3N  
50/60 Hz

**4.033,00**  
120 / 0,71

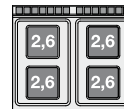

**CFC4-78ET CUCINA 4 PIASTRE VETROCERAMICA CM.  
75 X 57 - FORNO ELETTRICO STATICO CM.  
67X55X34H, TEMP: 50÷300°C, CON 1  
GRIGLIA CM.65X53 GN2/1 (INCLUSA 1  
TESTATA CHIUSURA PIANO MOD.TPA-7)**

08660832

**EN** Electric range N. 4 plates ceramic glass cm. 75 x 57 - traditional electric oven cm. 67x55x34h, temp: 50÷300°C, with 1 grid cm.65x53 GN2/1 (included 1 Head end filler strip mod.TPA-7) • **DE** Elektroherd N. 4 Ceran-Kochplatten cm. 75 x 57 - Statischer Elektro-Backofen cm. 67x55x34h, temp: 50÷300°C, mit 1 Rost cm.65x53 GN2/1 (inbegriffen 1 Abschluss-Element mod.TPA-7) • **FR** Fourneau électrique N. 4 plaques vitroceramique cm. 75 x 57 - Four électrique statique cm. 67x55x34h, temp: 50÷300°C avec 1 grille cm.65x53 GN2/1 (inclus 1 Élément de jonction top mod.TPA-7) • **ES** Cocina eléctrica N. 4 planchas vitrocerámica cm. 75 x 57 - Horno eléctrico estático cm. 67x55x34h, temp: 50÷300°C, con 1 parilla cm.65x53 GN2/1 (incluida 1 Chapa de cierre para top mod.TPA-7)  
**cm. 80x 70,5x 90h**



⚡ 15 kW  
400V~3N  
50/60 Hz

**4.070,00**  
107 / 0,71

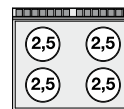

**CFVC4-78ET CUCINA 4 PIASTRE VETROCERAMICA CM.  
75 X 57 - FORNO ELETTRICO VENTILATO  
CM. 55X36X34H, TEMP: 50÷300°C, CON 1  
GRIGLIA CM.53X32,5 GN1/1 (INCLUSA 1  
TESTATA CHIUSURA PIANO MOD.TPA-7)**

08660837

**EN** Electric range N. 4 plates ceramic glass cm. 75 x 57 - electric fan oven cm. 55x36x34h, temp: 50÷300°C, with 1 grid cm.53x32,5 GN1/1 (included 1 Head end filler strip mod.TPA-7) • **DE** Elektroherd N. 4 Ceran-Kochplatten cm. 75 x 57 - Elektro-Heißluftofen cm. 55x36x34h, temp: 50÷300°C, mit 1 Rost cm.53x32,5 GN1/1 (inbegriffen 1 Abschluss-Element mod.TPA-7) • **FR** Fourneau électrique N. 4 plaques vitroceramique cm. 75 x 57 - Four à chaleur tournante électrique cm. 55x36x34h, temp: 50÷300°C avec 1 grille cm.53x32,5 GN1/1 (inclus 1 Élément de jonction top mod.TPA-7) • **ES** Cocina eléctrica N. 4 planchas vitrocerámica cm. 75 x 57 - Horno eléctrico ventilado cm. 55x36x34h, temp: 50÷300°C, con 1 parilla cm.53x32,5 GN1/1 (incluida 1 Chapa de cierre para top mod.TPA-7)  
**cm. 80x 70,5x 90h**

⚡ 15,32 kW  
400V~3N  
50/60 Hz

**4.379,00**  
107 / 0,71

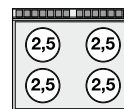

MOD. \_\_\_\_\_  
COD. \_\_\_\_\_

DESCRIZIONE/DESCRIPTION/BEZEICHNUNG/DESCRIPTION/DESCRIPCIÓN  
DIMENSIONI/DIMENSIONS/ABMESSUNGEN/DIMENSIONS/DIMENSIONES

POTENZA/POWER/LEISTUNG/PUISSANCE/POTENCIA  
VOLTAGGIO/VOLTAGE/SPANNUNG/VOLTAGE/VOLTAJE

⚡ kW  
kcal/h

⚡ kw  
V~  
Hz

PREZZO/PRICE €  
PREIS/PRIX/PRECIO €  
KG / M<sup>3</sup>

**CF4-78GP**  
08680850

**CUCINA 4 FUOCHI - FORNO A GAS STATICO**  
**CM. 67X55X34H, TEMP: 150÷300°C, CON**  
**1 GRIGLIA CM.65X53 GN2/1 (INCLUSA 1**  
**TESTATA CHIUSURA PIANO MOD.TPA-7)**

**EN** Gas Range - N. 4 burners Traditional gas-oven cm. 67x55x34h, temp: 150÷300°C, with 1 grid cm.65x53 GN2/1 (included 1 Head end filler strip mod.TPA-7)  
• **DE** Gasherd - N. 4 Kochstellen Statischer Gas-Backofen cm. 67x55x34h, temp: 150÷300°C, mit 1 Rost cm.65x53 GN2/1 (inbegriffen 1 Abschluss-Element mod.TPA-7)  
• **FR** Cuisiniere gaz - N. 4 feux vifs Four à gaz statique cm. 67x55x34h, temp: 150÷300°C avec 1 grille cm.65x53 GN2/1 (inclus 1 Élément de jonction top mod.TPA-7)  
• **ES** Cocina a gas - N. 4 quemadores Horno a gas estático cm. 67x55x34h, temp: 150÷300°C, con 1 parilla cm.65x53 GN2/1 (incluida 1 Chapa de cierre para top mod.TPA-7)  
**cm. 80x 70,5x 90h**



⚡ 29,3 kW  
25.198 kcal/h

**3.404,00**  
138 / 0,71

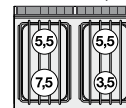

**CF4-78GPE**  
08690860

**CUCINA 4 FUOCHI - FORNO ELETTRICO**  
**STATICO CM. 67X55X34H, TEMP: 50÷300°C,**  
**CON 1 GRIGLIA CM.65X53 GN2/1 (INCLUSA**  
**1 TESTATA CHIUSURA PIANO MOD.TPA-7)**

**EN** Gas Range - N. 4 burners - traditional electric oven cm. 67x55x34h, temp: 50÷300°C, with 1 grid cm.65x53 GN2/1 (included 1 Head end filler strip mod.TPA-7)  
• **DE** Gasherd - N. 4 Kochstellen Statischer Elektro-Backofen cm. 67x55x34h, temp: 50÷300°C, mit 1 Rost cm.65x53 GN2/1 (inbegriffen 1 Abschluss-Element mod.TPA-7)  
• **FR** Cuisiniere gaz - N. 4 feux vifs Four électrique statique cm. 67x55x34h, temp: 50÷300°C avec 1 grille cm.65x53 GN2/1 (inclus 1 Élément de jonction top mod.TPA-7)  
• **ES** Cocina a gas - N. 4 quemadores Horno eléctrico estático cm. 67x55x34h, temp: 50÷300°C, con 1 parilla cm.65x53 GN2/1 (incluida 1 Chapa de cierre para top mod.TPA-7)  
**cm. 80x 70,5x 90h**



⚡ 22 kW  
18.920 kcal/h

**3.404,00**  
132 / 0,71

⚡ 5 kW  
400V~3N  
50/60 Hz

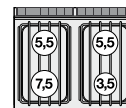

**CFV4-78GPE**  
08690865

**CUCINA 4 FUOCHI - FORNO ELETTRICO**  
**VENTILATO CM. 55X36X34H, TEMP:**  
**50÷300°C, CON 1 GRIGLIA CM.53X32,5**  
**GN1/1 (INCLUSA 1 TESTATA CHIUSURA**  
**PIANO MOD.TPA-7)**

**EN** Gas Range - N. 4 burners - electric fan oven cm. 55x36x34h, temp: 50÷300°C, with 1 grid cm.53x32,5 GN1/1 (included 1 Head end filler strip mod.TPA-7)  
• **DE** Gasherd - N. 4 Kochstellen Elektro-Heißluftofen cm. 55x36x34h, temp: 50÷300°C, mit 1 Rost cm.53x32,5 GN1/1 (inbegriffen 1 Abschluss-Element mod.TPA-7)  
• **FR** Cuisiniere gaz - N. 4 feux vifs Four à chaleur tournante électrique cm. 55x36x34h, temp: 50÷300°C avec 1 grille cm.53x32,5 GN1/1 (inclus 1 Élément de jonction top mod.TPA-7)  
• **ES** Cocina a gas - N. 4 quemadores Horno eléctrico ventilado cm. 55x36x34h, temp: 50÷300°C, con 1 parilla cm.53x32,5 GN1/1 (incluida 1 Chapa de cierre para top mod.TPA-7)  
**cm. 80x 70,5x 90h**

⚡ 22 kW  
18.920 kcal/h

**3.732,00**  
132 / 0,71

⚡ 5,32 kW  
400V~3N  
230V~3  
50/60 Hz

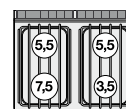



MOD. \_\_\_\_\_  
COD. \_\_\_\_\_

DESCRIZIONE/DESCRIPTION/BEZEICHNUNG/DESCRIPTION/DESCRIPCIÓN  
DIMENSIONI/DIMENSIONS/ABMESSUNGEN/DIMENSIONS/DIMENSIONES

POTENZA/POWER/LEISTUNG/PUISSANCE/POTENCIA  
VOLTAGGIO/VOLTAGE/SPANNUNG/VOLTAGE/VOLTAJE

⚡ kW \_\_\_\_\_  
kcal/h \_\_\_\_\_

PREZZO/PRICE € \_\_\_\_\_  
PREIS/PRIX/PRECIO € \_\_\_\_\_  
KG / M<sup>3</sup>

**CF4A-78GP**  
08750850

**CUCINA ACQUA 4 FUOCHI - FORNO A GAS STATICO CM. 67X55X34H, TEMP: 150÷300°C, CON 1 GRIGLIA CM.65X53 GN2/1 - RUBINETTO CARICO ACQUA, SFIORATORE (INCLUSA 1 TESTATA CHIUSURA PIANO MOD. TPA-7)**

**EN** Water range - N. 4 burners Traditional gas-oven cm. 67x55x34h, temp: 150÷300°C, with 1 grid cm.65x53 GN2/1 - Water loading tap + overflow device (included 1 Head end filler strip mod.TPA-7) • **DE** Wasser herd - N. 4 Kochstellen Statischer Gas-Backofen cm. 67x55x34h, temp: 150÷300°C, mit 1 Rost cm.65x53 GN2/1 - Wasserlauf-Hahn + Überlauf-Vorrichtung (inbegriffen 1 Abschluss-Element mod. TPA-7) • **FR** Cuisinière l'eau - N. 4 feux vifs Four à gaz statique cm. 67x55x34h, temp: 150÷300°C avec 1 grille cm.65x53 GN2/1 - Robinet d'arrivée d'eau trop plein (inclus 1 Élément de jonction top mod.TPA-7) • **ES** Cocina a agua - N. 4 quemadores Horno a gas estático cm. 67x55x34h, temp: 150÷300°C, con 1 parilla cm.65x53 GN2/1 - Grifo carga agua + vertedero (incluida 1 Chapa de cierre para top mod.TPA-7)  
**cm. 80x 70,5x 90h**



⚡ 35,3 kW \_\_\_\_\_ **4.781,00**  
30.358 kcal/h \_\_\_\_\_ 138 / 0,71

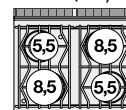

**CF6-712ETV**  
08661230

**CUCINA 6 PIASTRE - FORNO ELETTRICO STATICO CM. 67X55X34H, TEMP: 50÷300°C, CON 1 GRIGLIA CM.65X53 GN2/1 - VANO NEUTRO CON PORTA (INCLUSA 1 TESTATA CHIUSURA PIANO MOD.TPA-7)**

**EN** Electric range - N. 6 plates Traditional electric oven cm. 67x55x34h, temp: 50÷300°C, with 1 grid cm.65x53 GN2/1 - Neutral cabinet with door (included 1 Head end filler strip mod.TPA-7) • **DE** Elektroherd - N. 6 Kochplatten Statischer Elektro-Backofen cm. 67x55x34h, temp: 50÷300°C, mit 1 Rost cm.65x53 GN2/1 - Neutrales Schrankelement mit Tür (inbegriffen 1 Abschluss-Element mod.TPA-7) • **FR** Fourneau électrique - N. 6 plaques Four électrique statique cm. 67x55x34h, temp: 50÷300°C avec 1 grille cm.65x53 GN2/1 - Element neutre avec porte (inclus 1 Élément de jonction top mod.TPA-7) • **ES** Cocina eléctrica - N. 6 planchas Horno eléctrico estático cm. 67x55x34h, temp: 50÷300°C, con 1 parilla cm.65x53 GN2/1 - Armario neutro con puerta (incluida 1 Chapa de cierre para top mod.TPA-7)  
**cm. 120x 70,5x 90h**



⚡ 20,6 kW \_\_\_\_\_ **3.829,00**  
400V~3N \_\_\_\_\_ 134 / 1,05  
50/60 Hz



**CFV6-712ETV**  
08661235

**CUCINA 6 PIASTRE - FORNO ELETTRICO VENTILATO CM. 55X36X34H, TEMP: 50÷300°C, CON 1 GRIGLIA CM.53X32,5 GN1/1 - VANO NEUTRO CON PORTA (INCLUSA 1 TESTATA CHIUSURA PIANO MOD. TPA-7)**

**EN** Electric range - N. 6 plates electric fan oven cm. 55x36x34h, temp: 50÷300°C, with 1 grid cm.53x32,5 GN1/1 - Neutral cabinet with door (included 1 Head end filler strip mod.TPA-7) • **DE** Elektroherd - N. 6 Kochplatten Elektro-Heißluftofen cm. 55x36x34h, temp: 50÷300°C, mit 1 Rost cm.53x32,5 GN1/1 - Neutrales Schrankelement mit Tür (inbegriffen 1 Abschluss-Element mod.TPA-7) • **FR** Fourneau électrique - N. 6 plaques Four à chaleur tournante électrique cm. 55x36x34h, temp: 50÷300°C avec 1 grille cm.53x32,5 GN1/1 - Element neutre avec porte (inclus 1 Élément de jonction top mod.TPA-7) • **ES** Cocina eléctrica - N. 6 planchas Horno eléctrico ventilado cm. 55x36x34h, temp: 50÷300°C, con 1 parilla cm.53x32,5 GN1/1 - Armario neutro con puerta (incluida 1 Chapa de cierre para top mod.TPA-7)  
**cm. 120x 70,5x 90h**

⚡ 20,92 kW \_\_\_\_\_ **4.135,00**  
400V~3N \_\_\_\_\_ 134 / 1,05  
50/60 Hz

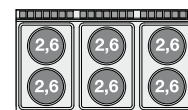

MOD. \_\_\_\_\_  
COD. \_\_\_\_\_

DESCRIZIONE/DESCRIPTION/BEZEICHNUNG/DESCRIPTION/DESCRIPCIÓN  
DIMENSIONI/DIMENSIONS/ABMESSUNGEN/DIMENSIONS/DIMENSIONES

POTENZA/POWER/LEISTUNG/PUISSANCE/POTENCIA  
VOLTAGGIO/VOLTAGE/SPANNUNG/VOLTAGE/VOLTAJE

⚡ kW  
kcal/h

⚡ kW  
V~  
Hz

PREZZO/PRICE €  
PREIS/PRIX/PRECIO €  
KG / M<sup>3</sup>

**CFQ6-712ETV CUCINA 6 PIASTRE QUADRE - FORNO  
ELETTRICO STATICO CM. 67X55X34H, TEMP:  
50÷300°C, CON 1 GRIGLIA CM.65X53 GN2/1  
- VANO NEUTRO CON PORTA (INCLUSA 1  
TESTATA CHIUSURA PIANO MOD.TPA-7)**  
**EN** Electric range - N. 6 square plates Traditional  
electric oven cm. 67x55x34h, temp: 50÷300°C, with  
1 grid cm.65x53 GN2/1 - Neutral cabinet with door  
(included 1 Head end filler strip mod.TPA-7) • **DE**  
Elektroherd - N. 6 quadratischen Platten Statischer  
Elektro-Backofen cm. 67x55x34h, temp: 50÷300°C, mit  
1 Rost cm.65x53 GN2/1 - Neutrales Schrankelement  
mit Tür (inbegriffen 1 Abschluss-Element mod.TPA-7)  
• **FR** Fourneau électrique - N. 6 plaques carrés Four  
électrique statique cm. 67x55x34h, temp: 50÷300°C  
avec 1 grille cm.65x53 GN2/1 - Element neutre avec  
porte (inclus 1 Élément de jonction top mod.TPA-7) •  
**ES** Cocina eléctrica - N. 6 planchas cuadradas Horno  
eléctrico estático cm. 67x55x34h, temp: 50÷300°C, con  
1 parilla cm.65x53 GN2/1 - Armario neutro con puerta  
(incluida 1 Chapa de cierre para top mod.TPA-7)  
**cm. 120x 70,5x 90h**



⚡ 20,6 kW **5.129,00**  
400V~3N 146 / 1,05  
50/60 Hz

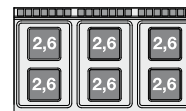

**CFVQ6-712ETV CUCINA 6 PIASTRE QUADRE - FORNO  
ELETTRICO VENTILATO CM. 55X36X34H,  
TEMP: 50÷300°C, CON 1 GRIGLIA  
CM.53X32,5 GN1/1 - VANO NEUTRO CON  
PORTA (INCLUSA 1 TESTATA CHIUSURA PIANO  
MOD.TPA-7)**  
**EN** Electric range - N. 6 square plates electric fan  
oven cm. 55x36x34h, temp: 50÷300°C, with 1 grid  
cm.53x32,5 GN1/1 - Neutral cabinet with door  
(included 1 Head end filler strip mod.TPA-7) • **DE**  
Elektroherd - N. 6 quadratischen Platten Elektro-  
Heißluftofen cm. 55x36x34h, temp: 50÷300°C, mit 1  
Rost cm.53x32,5 GN1/1 - Neutrales Schrankelement  
mit Tür (inbegriffen 1 Abschluss-Element mod.TPA-7)  
• **FR** Fourneau électrique - N. 6 plaques carrés Four  
à chaleur tournante électrique cm. 55x36x34h, temp:  
50÷300°C avec 1 grille cm.53x32,5 GN1/1 - Element  
neutre avec porte (inclus 1 Élément de jonction top mod.  
TPA-7) • **ES** Cocina eléctrica - N. 6 planchas cuadradas  
Horno eléctrico ventilado cm. 55x36x34h, temp:  
50÷300°C, con 1 parilla cm.53x32,5 GN1/1 - Armario  
neutro con puerta (incluida 1 Chapa de cierre para top  
mod.TPA-7)  
**cm. 120x 70,5x 90h**

⚡ 20,92 kW **5.431,00**  
400V~3N 146 / 1,05  
50/60 Hz

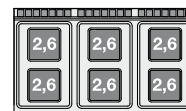

**CF6-712ET CUCINA 6 PIASTRE FORNO ELETTRICO STATICO  
CM. 107X55X34H, TEMP: 50÷300°C, CON  
1 GRIGLIA CM.105X53 (INCLUSA 1 TESTATA  
CHIUSURA PIANO MOD.TPA-7)**  
**EN** Electric Range - N. 6 plates Traditional electric  
oven cm. 107x55x34h, temp: 50÷300°C, with 1 grid  
cm.105x53 (included 1 Head end filler strip mod.TPA-7)  
• **DE** Elektroherd - N. 6 Kochplatten Statischer Elektro-  
Backofen cm. 107x55x34h, temp: 50÷300°C, mit 1  
Rost cm.105x53 (inbegriffen 1 Abschluss-Element mod.  
TPA-7) • **FR** Fourneau électrique - N. 6 plaques Four  
électrique statique cm. 107x55x34h, temp: 50÷300°C,  
avec 1 grille cm.105x53 (inclus 1 Élément de jonction  
top mod.TPA-7) • **ES** Cocina eléctrica - N. 6 planchas  
Horno eléctrico estático cm. 107x55x34h, temp:  
50÷300°C, con 1 parilla cm.105x53 (incluida 1 Chapa  
de cierre para top mod.TPA-7)  
**cm. 120x 70,5x 90h**



⚡ 22,5 kW **4.319,00**  
400V~3N 136 / 1,05  
50/60 Hz

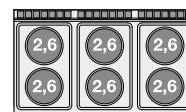

MOD. \_\_\_\_\_  
COD. \_\_\_\_\_

DESCRIZIONE/DESCRIPTION/BEZEICHNUNG/DESCRIPTION/DESCRIPCIÓN  
DIMENSIONI/DIMENSIONS/ABMESSUNGEN/DIMENSIONS/DIMENSIONES

POTENZA/POWER/LEISTUNG/PUISSANCE/POTENCIA  
VOLTAGGIO/VOLTAGE/SPANNUNG/VOLTAGE/VOLTAJE

⚡ kW  
kcal/h

⚡ kW  
V~  
Hz

PREZZO/PRICE €  
PREIS/PRIX/PRECIO €  
KG / M<sup>3</sup>

**CFQ6-712ET CUCINA 6 PIASTRE QUADRE FORNO  
ELETTRICO STATICO CM. 107X55X34H, TEMP:  
50÷300°C, CON 1 GRIGLIA CM.105X53  
(INCLUSA 1 TESTATA CHIUSURA PIANO MOD.  
TPA-7)**

08661233

**EN** Electric Range - N. 6 square plates Traditional electric oven cm. 107x55x34h, temp: 50÷300°C, with 1 grid cm.105x53 (included 1 Head end filler strip mod.TPA-7) • **DE** Elektroherd - N. 6 quadratischen Platten Statischer Elektro-Backofen cm. 107x55x34h, temp: 50÷300°C, mit 1 Rost cm.105x53 (inbegriffen 1 Abschluss-Element mod.TPA-7) • **FR** Fourneau électrique - N. 6 plaques carrés Four électrique statique cm. 107x55x34h, temp: 50÷300°C, avec 1 grille cm.105x53 (inclus 1 Elément de jonction top mod.TPA-7) • **ES** Cocina eléctrica - N. 6 planchas cuadradas Horno eléctrico estático cm. 107x55x34h, temp: 50÷300°C, con 1 parilla cm.105x53 (incluida 1 Chapa de cierre para top mod.TPA-7)  
**cm. 120x 70,5x 90h**



⚡ 22,5 kW **5.544,00**  
400V~3N 148 / 1,05  
50/60 Hz

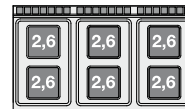

**CF6-712GPV CUCINA 6 FUOCHI FORNO A GAS STATICO  
CM. 67X55X34H, TEMP: 150÷300°C, CON 1  
GRIGLIA CM.65X53 GN2/1 - VANO NEUTRO  
CON PORTA (INCLUSA 1 TESTATA CHIUSURA  
PIANO MOD.TPA-7)**

08681251

**EN** Gas Range - N. 6 burners Traditional gas-oven GN cm. 67x55x34h, temp: 150÷300°C, with 1 grid cm.65x53 GN2/1 - Neutral cabinet with door (included 1 Head end filler strip mod.TPA-7) • **DE** Gasherd - N. 6 Kochstellen - Statischer Gas-Backofen cm. 67x55x34h, temp: 150÷300°C, mit 1 Rost cm.65x53 GN2/1 - Neutrales Schrankelement mit Tür (inbegriffen 1 Abschluss-Element mod.TPA-7) • **FR** Cuisiniere Gaz - N. 6 feux vifs Four à gaz statique cm. 67x55x34h, temp: 150÷300°C avec 1 grille cm.65x53 GN2/1 - Elément neutre avec porte (inclus 1 Elément de jonction top mod.TPA-7) • **ES** Cocina a gas - N. 6 quemadores Horno a gas estático cm. 67x55x34h, temp: 150÷300°C, con 1 parilla cm.65x53 GN2/1 - Armario neutro con puerta (incluida 1 Chapa de cierre para top mod.TPA-7)  
**cm. 120x 70,5x 90h**



⚡ 42,3 kW **4.534,00**  
36.378 kcal/h 178 / 1,05

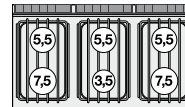

**CF6-712GPEV CUCINA 6 FUOCHI - FORNO ELETTRICO  
STATICO CM. 67X55X34H, TEMP: 50÷300°C,  
CON 1 GRIGLIA CM.65X53 GN2/1 - VANO  
NEUTRO CON PORTA (INCLUSA 1 TESTATA  
CHIUSURA PIANO MOD.TPA-7)**

08691261

**EN** Gas Range - N. 6 burners - traditional electric oven cm. 67x55x34h, temp: 50÷300°C, with 1 grid cm.65x53 GN2/1 - Neutral cabinet with door (included 1 Head end filler strip mod.TPA-7) • **DE** Gasherd - N. 6 Kochstellen Statischer Elektro-Backofen cm. 67x55x34h, temp: 50÷300°C, mit 1 Rost cm.65x53 GN2/1 - Neutrales Schrankelement mit Tür (inbegriffen 1 Abschluss-Element mod.TPA-7) • **FR** Cuisiniere gaz - N. 6 feux vifs Four électrique statique cm. 67x55x34h, temp: 50÷300°C avec 1 grille cm.65x53 GN2/1 - Elément neutre avec porte (inclus 1 Elément de jonction top mod.TPA-7) • **ES** Cocina a gas - N. 6 quemadores Horno eléctrico estático cm. 67x55x34h, temp: 50÷300°C, con 1 parilla cm.65x53 GN2/1 - Armario neutro con puerta (incluida 1 Chapa de cierre para top mod.TPA-7)  
**cm. 120x 70,5x 90h**



⚡ 35 kW **4.534,00**  
30.100 kcal/h 177 / 1,05

⚡ 5 kW  
400V~3N  
50/60 Hz

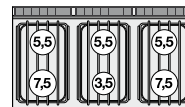

# CUCINE A GAS CON FORNO ELETTRICO

MOD. \_\_\_\_\_  
COD. \_\_\_\_\_

DESCRIZIONE / DESCRIPTION / BEZEICHNUNG / DESCRIPTION / DESCRIPCIÓN  
DIMENSIONI / DIMENSIONS / ABMESSUNGEN / DIMENSIONS / DIMENSIONES

POTENZA / POWER / LEISTUNG / PUISSANCE / POTENCIA  
VOLTAGGIO / VOLTAGE / SPANNUNG / VOLTAGE / VOLTAJE

⚡ kW  
kcal/h

⚡ kW  
V~  
Hz

PREZZO / PRICE €  
PREIS / PRIX / PRECIO  
KG / M<sup>3</sup>

**CFV6-712GPEV CUCINA 6 FUOCHI - FORNO ELETTRICO**  
08691266 **VENTILATO CM. 55X36X34H, TEMP: 50÷300°C, CON 1 GRIGLIA CM.53X32,5 GN1/1 - VANO NEUTRO CON PORTA (INCLUSA 1 TESTATA CHIUSURA PIANO MOD. TPA-7)**

**EN** Gas Range - N. 6 burners - electric fan oven cm. 55x36x34h, temp: 50÷300°C, with 1 grid cm.53x32,5 GN1/1 - Neutral cabinet with door (included 1 Head end filler strip mod.TPA-7) • **DE** Gas Range - N. 6 burners - electric fan oven cm. 55x36x34h, temp: 50÷300°C, mit 1 Rost cm.53x32,5 GN1/1 - Neutral cabinet with door (inbegriffen 1 Abschluss-Element mod. TPA-7) • **FR** Gas Range - N. 6 burners - electric fan oven cm. 55x36x34h, temp: 50÷300°C avec 1 grille cm.53x32,5 GN1/1 - Neutral cabinet with door (inclus 1 Élément de jonction top mod.TPA-7) • **ES** Gas Range - N. 6 burners - electric fan oven cm. 55x36x34h, temp: 50÷300°C, con 1 parilla cm.53x32,5 GN1/1 - Neutral cabinet with door (incluida 1 Chapa de cierre para top mod.TPA-7)

**cm. 120x 70,5x 90h**



⚡ 35 kW  
30.100 kcal/h **4.837,00**  
177 / 1,05

⚡ 5,32 kW  
400V~3N  
230V~3  
50/60 Hz

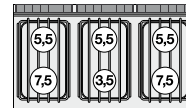

**CFA6-712GPV CUCINA ACQUA 6 FUOCHI - FORNO A GAS**  
08751251 **STATICO CM. 67X55X34H, TEMP: 150÷300°C, CON 1 GRIGLIA CM.65X53 GN2/1 - VANO NEUTRO CON PORTA - RUBINETTO CARICO ACQUA, SFIORATORE (INCLUSA 1 TESTATA CHIUSURA PIANO MOD.TPA-7)**

**EN** Water range - N. 6 burners - Traditional gas-oven cm. 67x55x34h, temp: 150÷300°C, with 1 grid cm.65x53 GN2/1 - Neutral cabinet with door - Water loading tap + overflow device (included 1 Head end filler strip mod.TPA-7) • **DE** Wasser herd - N. 6 Kochstellen - Statischer Gas-Backofen cm. 67x55x34h, temp: 150÷300°C, mit 1 Rost cm.65x53 GN2/1 - Neutrales Schrankelement mit Tür - Wasserlauf-Hahn + Überlauf-Vorrichtung (inbegriffen 1 Abschluss-Element mod.TPA-7) • **FR** Cuisinière l'eau - N. 6 feux vifs Four à gaz statique cm. 67x55x34h, temp: 150÷300°C avec 1 grille cm.65x53 GN2/1 - Element neutre avec porte - Robinet d'arrivée d'eau trop plein (inclus 1 Élément de jonction top mod.TPA-7) • **ES** Cocina a agua N. 6 quemadores Horno a gas estático cm. 67x55x34h, temp: 150÷300°C, con 1 parilla cm.65x53 GN2/1 - Armario neutro con puerta - Grifo carga agua + vertedero (incluida 1 Chapa de cierre para top mod. TPA-7)

**cm. 120x 70,5x 90h**



⚡ 49,3 kW  
42.398 kcal/h **5.556,00**  
178 / 1,05

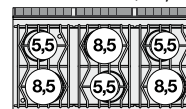

**CF6-712GP CUCINA 6 FUOCHI FORNO A GAS STATICO**  
08681250 **CM. 107X55X34H, TEMP: 150÷300°C, CON 1 GRIGLIA CM.105X53 (INCLUSA 1 TESTATA CHIUSURA PIANO MOD.TPA-7)**

**EN** Gas Range - N. 6 burners Traditional gas-oven cm. 107x55x34h, temp: 150÷300°C, with 1 grid cm.105x53 (included 1 Head end filler strip mod. TPA-7) • **DE** Gasherd - N. 6 Kochstellen Statischer Gas-Backofen cm. 107x55x34h, temp: 150÷300°C, mit 1 Rost cm.105x53 (inbegriffen 1 Abschluss-Element mod. TPA-7) • **FR** Cuisinière gaz - N. 6 feux vifs Four à gaz statique cm. 107x55x34h, temp: 150÷300°C, avec 1 grille cm.105x53 (inclus 1 Élément de jonction top mod. TPA-7) • **ES** Cocina a gas - N. 6 quemadores Horno a gas estático cm. 107x55x34h, temp: 150÷300°C, con 1 parilla cm.105x53 (incluida 1 Chapa de cierre para top mod.TPA-7)

**cm. 120x 70,5x 90h**



⚡ 46 kW  
39.560 kcal/h **5.071,00**  
197 / 1,05

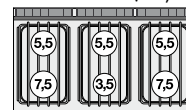



# CUCINE A GAS CON FORNO ELETTRICO

MOD. \_\_\_\_\_  
COD. \_\_\_\_\_

DESCRIZIONE/DESCRIPTION/BEZEICHNUNG/DESCRIPTION/DESCRIPCIÓN  
DIMENSIONI/DIMENSIONS/ABMESSUNGEN/DIMENSIONS/DIMENSIONES

POTENZA/POWER/LEISTUNG/PUISSANCE/POTENCIA  
VOLTAGGIO/VOLTAGE/SPANNUNG/VOLTAGE/VOLTAJE

⚡ kW  
kcal/h

⚡ kW  
V~  
Hz

PREZZO/PRICE €  
PREIS/PRIX/PRECIO €  
KG / M<sup>3</sup>

**CF6-712GPE CUCINA 6 FUOCHI FORNO ELETTRICO STATICO**  
08691260  
**CM. 107X55X34H, TEMP: 50÷300°C, CON 1 GRIGLIA CM.105X53 (INCLUSA 1 TESTATA CHIUSURA PIANO MOD.TPA-7)**

**EN** Gas Range - N. 6 burners Traditional electric oven cm. 107x55x34h, temp: 50÷300°C, with 1 grid cm.105x53 (included 1 Head end filler strip mod. TPA-7) • **DE** Gasherd - N. 6 Kochstellen Statischer Elektro-Backofen cm. 107x55x34h, temp: 50÷300°C, mit 1 Rost cm.105x53 (inbegriffen 1 Abschluss-Element mod.TPA-7) • **FR** Cuisiniere gaz - N. 6 feux vifs Four électrique statique cm. 107x55x34h, temp: 50÷300°C, avec 1 grille cm.105x53 (inclus 1 Élément de jonction top mod.TPA-7) • **ES** Cocina a gas - N. 6 quemadores Horno eléctrico estático cm. 107x55x34h, temp: 50÷300°C, con 1 parilla cm.105x53 (incluida 1 Chapa de cierre para top mod.TPA-7)  
**cm. 120x 70,5x 90h**



⚡ 35 kW  
30.100 kcal/h

**5.071,00**  
190 / 1,05

⚡ 6,9 kW  
400V~3N  
50/60 Hz

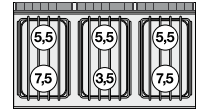

**PC-74ET PIANO COTTURA TRIFASE SU MOBILE A GIORNO - N. 2 PIASTRE (INCLUSA 1 TESTATA CHIUSURA PIANO MOD.TPA-7)**  
08030430

**EN** Boiling unit threephase on open cabinet - N. 2 plates (included 1 Head end filler strip mod.TPA-7) • **DE** Kochplatte dreiphasig mit offenem Unterbau N. 2 Kochplatten (inbegriffen 1 Abschluss-Element mod.TPA-7) • **FR** Rechaud électriques sur armoire ouvert - N. 2 plaques (inclus 1 Élément de jonction top mod.TPA-7) • **ES** Sobre de cocción trifásico sobre mueble abierto N. 2 planchas (incluida 1 Chapa de cierre para top mod. TPA-7)  
**cm. 40x 70,5x 90h**



⚡ 5,2 kW  
400V~2N  
230V~3  
230V~  
50/60 Hz

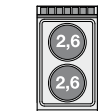

**PC-78ET PIANO COTTURA TRIFASE SU MOBILE A GIORNO N. 4 PIASTRE (INCLUSA 1 TESTATA CHIUSURA PIANO MOD.TPA-7)**  
08030830

**EN** Threephase boiling unit on open cabinet - N. 4 plates (included 1 Head end filler strip mod.TPA-7) • **DE** Kochplatte dreiphasig mit offenem Unterbau N. 4 Kochplatten (inbegriffen 1 Abschluss-Element mod. TPA-7) • **FR** Rechaud triphase sur armoire ouvert - N. 4 plaques (inclus 1 Élément de jonction top mod.TPA-7) • **ES** Sobre de cocción trifásico sobre mueble abierto N. 4 planchas (incluida 1 Chapa de cierre para top mod. TPA-7)  
**cm. 80x 70,5x 90h**



⚡ 10,4 kW  
400V~3N  
230V~3  
50/60 Hz

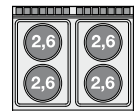

**PC-712ET PIANO COTTURA TRIFASE SU MOBILE A GIORNO N. 6 PIASTRE (INCLUSA 1 TESTATA CHIUSURA PIANO MOD.TPA-7)**  
08031230

**EN** Threephase boiling unit on open cabinet - N. 6 plates (included 1 Head end filler strip mod.TPA-7) • **DE** Kochplatte dreiphasig mit offenem Unterbau N. 6 Kochplatten (inbegriffen 1 Abschluss-Element mod. TPA-7) • **FR** Rechaud triphase sur armoire ouvert - N. 6 plaques (inclus 1 Élément de jonction top mod.TPA-7) • **ES** Sobre de cocción trifásico sobre mueble abierto N. 6 planchas (incluida 1 Chapa de cierre para top mod. TPA-7)  
**cm. 120x 70,5x 90h**



⚡ 15,6 kW  
400V~3N  
230V~3  
50/60 Hz

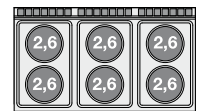

**PCQ-74ET PIANO COTTURA TRIFASE SU MOBILE A GIORNO - N. 2 PIASTRE QUADRE (INCLUSA 1 TESTATA CHIUSURA PIANO MOD.TPA-7)**  
08030431

**EN** Boiling unit threephase on open cabinet - N. 2 square plates (included 1 Head end filler strip mod.TPA-7) • **DE** Kochplatte dreiphasig mit offenem Unterbau N. 2 quadratischen Platten (inbegriffen 1 Abschluss-Element mod.TPA-7) • **FR** Rechaud électriques sur armoire ouvert - N. 2 plaques carrés (inclus 1 Élément de jonction top mod.TPA-7) • **ES** Sobre de cocción trifásico sobre mueble abierto N. 2 planchas cuadradas (incluida 1 Chapa de cierre para top mod.TPA-7)  
**cm. 40x 70,5x 90h**



⚡ 5,2 kW  
400V~2N  
230V~3  
230V~  
50/60 Hz

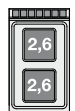

Le immagini presentate non sono vincolanti. La ditta si riserva di apportare modifiche senza preavviso. • The pictures are purely representative. The manufacturer reserves the right to modify the technical data and models without previous notice. • Les images

LO

présentées ne nous engagent pas. La Société se réserve le droit d'apporter tout modification sans préavis. • Die dargestellten Abbildungen sind nicht verbindlich. Technische Änderungen vorbehalten. • Las imágenes presentadas no son vinculantes. El Fabricante se reserva el derecho de modificar sus productos sin previo aviso.

01/20

123



# PIANI COTTURA ELETTRICI

MOD. \_\_\_\_\_  
COD. \_\_\_\_\_

DESCRIZIONE/DESCRIPTION/BEZEICHNUNG/DESCRIPTION/DESCRIPCIÓN  
DIMENSIONI/DIMENSIONS/ABMESSUNGEN/DIMENSIONS/DIMENSIONES

POTENZA/POWER/LEISTUNG/PUISSANCE/POTENCIA  
VOLTAGGIO/VOLTAGE/SPANNUNG/VOLTAGE/VOLTAJE

⚡ kcal/h  
⚡ kW  
V~  
Hz

PREZZO/PRICE €  
PREIS/PRIX/PRECIO €  
KG / M<sup>3</sup>

**PCQ-78ET**  
08030831

**PIANO COTTURA TRIFASE SU MOBILE A GIORNO - N. 4 PIASTRE QUADRE (INCLUSA 1 TESTATA CHIUSURA PIANO MOD.TPA-7)**  
**EN** Boiling unit threephase on open cabinet - N. 4 square plates (included 1 Head end filler strip mod.TPA-7) • **DE** Kochplatte dreiphasig mit offenem Unterbau N. 4 quadratischen Platten (inbegriffen 1 Abschluss-Element mod.TPA-7) • **FR** Rechaud électriques sur armoire ouvert - N. 4 plaques carrés (inclus 1 Élément de jonction top mod.TPA-7) • **ES** Sobre de cocción trifásico sobre mueble abierto N. 4 planchas cuadradas (incluida 1 Chapa de cierre para top mod.TPA-7)  
**cm. 80x 70,5x 90h**



⚡ 10,4 kW  
400V~3N  
230V~3  
50/60 Hz

**2.546,00**  
71 / 0,71

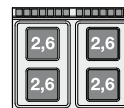

**PCQ-712ET**  
08031231

**PIANO COTTURA TRIFASE SU MOBILE A GIORNO - N. 6 PIASTRE QUADRE (INCLUSA 1 TESTATA CHIUSURA PIANO MOD.TPA-7)**  
**EN** Boiling unit threephase on open cabinet - N. 6 square plates (included 1 Head end filler strip mod.TPA-7) • **DE** Kochplatte dreiphasig mit offenem Unterbau N. 6 quadratischen Platten (inbegriffen 1 Abschluss-Element mod.TPA-7) • **FR** Rechaud électriques sur armoire ouvert - N. 6 plaques carrés (inclus 1 Élément de jonction top mod.TPA-7) • **ES** Sobre de cocción trifásico sobre mueble abierto N. 6 planchas cuadradas (incluida 1 Chapa de cierre para top mod.TPA-7)  
**cm. 120x 70,5x 90h**



⚡ 15,6 kW  
400V~3N  
230V~3  
50/60 Hz

**3.629,00**  
103 / 1,05



**PCC-74ET**  
08030432

**PIANO COTTURA VETROCERAMICA TRIFASE SU MOBILE A GIORNO - N. 2 ZONE - VETRO CM.35X57 (INCLUSA 1 TESTATA CHIUSURA PIANO MOD.TPA-7)**  
**EN** Ceramic glass boiling unit on open cabinet - n. 2 zones - glass cm.35x57 (included 1 Head end filler strip mod.TPA-7) • **DE** Ceran-Kochplatte dreiphasig mit offenem Unterbau - 2 zonen - Glas 35x57 cm (inbegriffen 1 Abschluss-Element mod.TPA-7) • **FR** Plan de cuisson à vitroceramique triphasé sur armoire ouvert N. 2 zones - Verre cm.35x57 (inclus 1 Élément de jonction top mod.TPA-7) • **ES** Sobre de cocción trifásico vitrocerámica sobre mueble abierto - 2 zonas - vidrio cm.35x57 (incluida 1 Chapa de cierre para top mod.TPA-7)  
**cm. 40x 70,5x 90h**



⚡ 5 kW  
400V~2N  
230V~3  
230V~  
50/60 Hz

**1.792,00**  
41 / 0,37

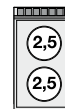

**PCC-78ET**  
08030832

**PIANO COTTURA VETROCERAMICA TRIFASE SU MOBILE A GIORNO - N. 4 ZONE - VETRO CM. 75X57 (INCLUSA 1 TESTATA CHIUSURA PIANO MOD.TPA-7)**  
**EN** Ceramic glass boiling unit on open cabinet - n. 4 zones - glass cm. 75 x 57 (included 1 Head end filler strip mod.TPA-7) • **DE** Ceran-Kochplatte dreiphasig mit offenem Unterbau - 4 zonen - Glas 75x57 cm (inbegriffen 1 Abschluss-Element mod.TPA-7) • **FR** Plan de cuisson à vitroceramique triphasé sur armoire ouvert N. 4 zones - Verre cm 75x57 (inclus 1 Élément de jonction top mod.TPA-7) • **ES** Sobre de cocción trifásico vitrocerámica sobre mueble abierto - 4 zonas - vidrio cm. 75 x 57 (incluida 1 Chapa de cierre para top mod.TPA-7)  
**cm. 80x 70,5x 90h**



⚡ 10 kW  
400V~3N  
230V~3  
50/60 Hz

**2.636,00**  
66 / 0,71

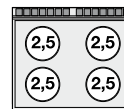

# PIANI COTTURA A INDUZIONE

MOD. \_\_\_\_\_  
COD. \_\_\_\_\_

DESCRIZIONE/DESCRIPTION/BEZEICHNUNG/DESCRIPTION/DESCRIPCIÓN  
DIMENSIONI/DIMENSIONS/ABMESSUNGEN/DIMENSIONS/DIMENSIONES

POTENZA/POWER/LEISTUNG/PUISSANCE/POTENCIA  
VOLTAGGIO/VOLTAGE/SPANNUNG/VOLTAGE/VOLTAJE

⚡ kW \_\_\_\_\_  
kcal/h \_\_\_\_\_  
V~ \_\_\_\_\_  
Hz \_\_\_\_\_

PREZZO/PRICE € \_\_\_\_\_  
PREIS/PRIX/PRECIO € \_\_\_\_\_  
KG / M<sup>3</sup> \_\_\_\_\_

**PCI-74ET**  
08030433

**PIANO COTTURA INDUZIONE TRIFASE - N. 2 ZONE - VETRO CM.35X57 (INCLUSA 1 TESTATA CHIUSURA PIANO MOD.TPA-7)**

**EN** Three-phase induction cooking - 2 zones - glass cm.35x57 (included 1 Head end filler strip mod.TPA-7) • **DE** Induktions-Kochplatte dreiphasig - 2 zonen - Glas 35x57 cm (inbegriffen 1 Abschluss-Element mod.TPA-7) • **FR** Plan de cuisson à induction triphasé N. 2 zones - Verre cm.35x57 (inclus 1 Élément de jonction top mod.TPA-7) • **ES** Encimera inducción trifásica - 2 zonas - Vidrio cm.35x57 (incluida 1 Chapa de cierre para top mod.TPA-7)  
**cm. 40x 70,5x 90h**



⚡ 10 kW \_\_\_\_\_ **6.819,00**  
400V~3 \_\_\_\_\_ 40 / 0,37  
50/60 Hz \_\_\_\_\_

**PCI-74ETD**  
08030438

**PIANO COTTURA INDUZIONE TRIFASE - N. 2 ZONE - VETRO CM.35X57 - COMANDI DIGITALI (INCLUSA 1 TESTATA CHIUSURA PIANO MOD.TPA-7)**

**EN** Three-phase induction cooking - 2 zones - glass cm.35x57 - digital controls (included 1 Head end filler strip mod.TPA-7) • **DE** Induktions-Kochplatte dreiphasig - 2 zonen - Glas 35x57 cm - digitale Steuerungen (inbegriffen 1 Abschluss-Element mod.TPA-7) • **FR** Plan de cuisson à induction triphasé N. 2 zones - Verre cm.35x57 - commandes numériques (inclus 1 Élément de jonction top mod.TPA-7) • **ES** Encimera inducción trifásica - 2 zonas - Vidrio cm.35x57 - controles digitales (incluida 1 Chapa de cierre para top mod.TPA-7)  
**cm. 40x 70,5x 90h**



⚡ 10 kW \_\_\_\_\_ **7.302,00**  
400V~3 \_\_\_\_\_ 40 / 0,37  
50/60 Hz \_\_\_\_\_

**PCIW-74ET**  
08030434

**PIANO COTTURA INDUZIONE TRIFASE "WOK" - N. 1 ZONA - VETRO Ø 30 CM. (INCLUSA 1 TESTATA CHIUSURA PIANO MOD.TPA-7)**

**EN** Three-phase induction cooking "WOK" - 1 zone - glass Ø 30 cm (included 1 Head end filler strip mod.TPA-7) • **DE** Induktions-Kochplatte "WOK" dreiphasig - 1 zonen - Glas Ø 30 cm (inbegriffen 1 Abschluss-Element mod.TPA-7) • **FR** Plan de cuisson à induction "WOK" triphasé N. 1 zone - Verre cm Ø 30 (inclus 1 Élément de jonction top mod.TPA-7) • **ES** Encimera inducción "WOK" trifásica - 1 zona - Vidrio Ø 30 cm (incluida 1 Chapa de cierre para top mod.TPA-7)  
**cm. 40x 70,5x 90h**



⚡ 5 kW \_\_\_\_\_ **5.202,00**  
400V~3 \_\_\_\_\_ 38 / 0,37  
50/60 Hz \_\_\_\_\_

**PCIW-74ETD PIANO COTTURA INDUZIONE TRIFASE "WOK" - N. 1 ZONA - VETRO Ø 30 CM. - COMANDI DIGITALI (INCLUSA 1 TESTATA CHIUSURA PIANO MOD.TPA-7)**

08030439

**EN** Three-phase induction cooking "WOK" - 1 zone - glass Ø 30 cm - digital controls (included 1 Head end filler strip mod.TPA-7) • **DE** Induktions-Kochplatte "WOK" dreiphasig - 1 zonen - Glas Ø 30 cm - digitale Steuerungen (inbegriffen 1 Abschluss-Element mod.TPA-7) • **FR** Plan de cuisson à induction "WOK" triphasé N. 1 zone - Verre cm Ø 30 - commandes numériques (inclus 1 Élément de jonction top mod.TPA-7) • **ES** Encimera inducción "WOK" trifásica - 1 zona - Vidrio Ø 30 cm+Z271 (incluida 1 Chapa de cierre para top mod.TPA-7)  
**cm. 40x 70,5x 90h**



⚡ 5 kW \_\_\_\_\_ **5.444,00**  
400V~3 \_\_\_\_\_ 38 / 0,37  
50/60 Hz \_\_\_\_\_



Le immagini presentate non sono vincolanti. La ditta si riserva di apportare modifiche senza preavviso. • The pictures are purely representative. The manufacturer reserves the right to modify the technical data and models without previous notice. • Les images

LO

présentées ne nous engagent pas. La Société se réserve le droit d'apporter tout modification sans préavis. • Die dargestellten Abbildungen sind nicht verbindlich. Technische Änderungen vorbehalten. • Las imágenes presentadas no son vinculantes. El Fabricante se reserva el derecho de modificar sus productos sin previo aviso.

01/20

125

70

# PIANI COTTURA A INDUZIONE

MOD. \_\_\_\_\_  
COD. \_\_\_\_\_

DESCRIZIONE/DESCRIPTION/BEZEICHNUNG/DESCRIPTION/DESCRIPCIÓN  
DIMENSIONI/DIMENSIONS/ABMESSUNGEN/DIMENSIONS/DIMENSIONES

POTENZA/POWER/LEISTUNG/PUISSANCE/POTENCIA  
VOLTAGGIO/VOLTAGE/SPANNUNG/VOLTAGE/VOLTAJE

⚡ kcal/h  
kW  
V~  
Hz

PREZZO/PRICE €  
PREIS/PRIX/PRECIO  
KG / M<sup>3</sup>

**PCI-78ET**  
08030833

**PIANO COTTURA INDUZIONE TRIFASE - N. 4 ZONE - VETRO CM.75X57 (INCLUSA 1 TESTATA CHIUSURA PIANO MOD.TPA-7)**  
**EN** Three-phase induction cooking - 4 zones - glass cm.75x57 (included 1 Head end filler strip mod.TPA-7)  
• **DE** Induktions-Kochplatte dreiphasig - 4 zonen - Glas 75x57 cm (inbegriffen 1 Abschluss-Element mod.TPA-7)  
• **FR** Plan de cuisson à induction triphasé N. 4 zones - Verre cm.75x57 (inclus 1 Élément de jonction top mod.TPA-7)  
• **ES** Encimera inducción trifásica - 4 zonas - Vidrio cm.75x57 (incluida 1 Chapa de cierre para top mod.TPA-7)  
**cm. 80x 70,5x 90h**



⚡ 20 kW **12.960,00**  
400V~3 70 / 0,71  
50/60 Hz

**PCI-78ETD**  
08030838

**PIANO COTTURA INDUZIONE TRIFASE - N. 4 ZONE - VETRO CM.75X57 - COMANDI DIGITALI3 (INCLUSA 1 TESTATA CHIUSURA PIANO MOD.TPA-7)**  
**EN** Three-phase induction cooking - 4 zones - glass cm.75x57 - digital controls (included 1 Head end filler strip mod.TPA-7)  
• **DE** Induktions-Kochplatte dreiphasig - 4 zonen - Glas 75x57 cm - digitale Steuerungen (inbegriffen 1 Abschluss-Element mod.TPA-7)  
• **FR** Plan de cuisson à induction triphasé N. 4 zones - Verre cm.75x57 - commandes numériques (inclus 1 Élément de jonction top mod.TPA-7)  
• **ES** Encimera inducción trifásica - 4 zonas - Vidrio cm.75x57 - controles digitales (incluida 1 Chapa de cierre para top mod.TPA-7)  
**cm. 80x 70,5x 90h**

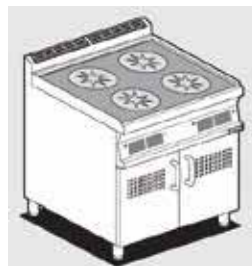

⚡ 20 kW **13.925,00**  
400V~3 70 / 0,71  
50/60 Hz

**PC-74GP**  
08210450

**PIANO COTTURA GAS SU MOBILE A GIORNO 2 FUOCHI (INCLUSA 1 TESTATA CHIUSURA PIANO MOD.TPA-7)**  
**EN** Gas heated boiling unit on open cabinet - 2 burners (included 1 Head end filler strip mod.TPA-7)  
• **DE** Gas-kochplatte mit offenem Unterbau - 2 Kochstellen (inbegriffen 1 Abschluss-Element mod.TPA-7)  
• **FR** Rechaud gaz sur armoire ouvert - 2 feux vifs (inclus 1 Élément de jonction top mod.TPA-7)  
• **ES** Sobres de cocción gas sobre mueble abierto - 2 quemadores (incluida 1 Chapa de cierre para top mod.TPA-7)  
**cm. 40x 70,5x 90h**



⚡ 13 kW **1.404,00**  
11.180 kcal/h 63 / 0,37

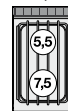

**PC-78GP**  
08210850

**PIANO COTTURA GAS SU MOBILE A GIORNO 4 FUOCHI (INCLUSA 1 TESTATA CHIUSURA PIANO MOD.TPA-7)**  
**EN** Gas heated boiling unit on open cabinet - 4 burners (included 1 Head end filler strip mod.TPA-7)  
• **DE** Gas-Kochplatte mit offenem Unterbau - 4 Kochstellen (inbegriffen 1 Abschluss-Element mod.TPA-7)  
• **FR** Rechaud gaz sur armoire ouvert - 4 feux vifs (inclus 1 Élément de jonction top mod.TPA-7)  
• **ES** Sobres de cocción gas sobre mueble abierto - 4 quemadores (incluida 1 Chapa de cierre para top mod.TPA-7)  
**cm. 80x 70,5x 90h**



⚡ 22 kW **2.246,00**  
18.920 kcal/h 76 / 0,71

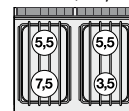

**PC-712GP**  
08211250

**PIANO COTTURA GAS SU MOBILE A GIORNO 6 FUOCHI (INCLUSA 1 TESTATA CHIUSURA PIANO MOD.TPA-7)**  
**EN** Gas heated boiling unit on open cabinet - 6 burners (included 1 Head end filler strip mod.TPA-7)  
• **DE** Gas-Kochplatte mit offenem Unterbau - 6 Kochstellen (inbegriffen 1 Abschluss-Element mod.TPA-7)  
• **FR** Rechaud gaz sur armoire ouvert - 6 feux vifs (inclus 1 Élément de jonction top mod.TPA-7)  
• **ES** Sobres de cocción gas sobre mueble abierto - 6 quemadores (incluida 1 Chapa de cierre para top mod.TPA-7)  
**cm. 120x 70,5x 90h**



⚡ 35 kW **3.216,00**  
30.100 kcal/h 126 / 1,05

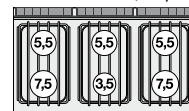

# PIANI COTTURA A GAS

MOD. \_\_\_\_\_  
COD. \_\_\_\_\_

DESCRIZIONE/DESCRIPTION/BEZEICHNUNG/DESCRIPTION/DESCRIPCIÓN  
DIMENSIONI/DIMENSIONS/ABMESSUNGEN/DIMENSIONS/DIMENSIONES

POTENZA/POWER/LEISTUNG/PUISSANCE/POTENCIA  
VOLTAGGIO/VOLTAGE/SPANNUNG/VOLTAGE/VOLTAJE

⚡ kW  
kcal/h

PREZZO/PRICE €  
KG / M<sup>3</sup>

**PC-716GP**  
08211650

**PIANO COTTURA GAS SU MOBILE A GIORNO  
8 FUOCHI (INCLUSA 1 TESTATA CHIUSURA  
PIANO MOD.TPA-7)**

**EN** Gas heated boiling unit on open cabinet - 8 burners (included 1 Head end filler strip mod.TPA-7) • **DE** Gas-Kochplatte mit offenem Unterbau - 8 Kochstellen (inbegriffen 1 Abschluss-Element mod.TPA-7) • **FR** Rechaud gaz sur armoire ouvert - 8 feux vifs (inclus 1 Élément de jonction top mod.TPA-7) • **ES** Sobres de cocción gas sobre mueble abierto - 8 quemadores (incluida 1 Chapa de cierre para top mod.TPA-7)  
**cm. 160x 70,5x 90h**



⚡ 44 kW  
37.840 kcal/h

**4.456,00**  
152 / 1,58

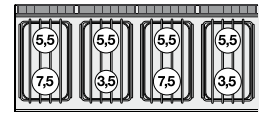

**PC1-74G**  
08210453

**PIANO COTTURA GAS SU MOBILE A GIORNO  
1 FUOCHI (INCLUSA 1 TESTATA CHIUSURA  
PIANO MOD.TPA-7)**

**EN** Gas heated boiling unit on open cabinet - 1 burners (included 1 Head end filler strip mod.TPA-7) • **DE** Gas-kochplatte mit offenem Unterbau - 1 Kochstellen (inbegriffen 1 Abschluss-Element mod.TPA-7) • **FR** Rechaud gaz sur armoire ouvert - 1 feux vifs (inclus 1 Élément de jonction top mod.TPA-7) • **ES** Sobres de cocción gas sobre mueble abierto - 1 quemadores (incluida 1 Chapa de cierre para top mod.TPA-7)  
**cm. 40x 70,5x 90h**



⚡ 10 kW  
8.600 kcal/h

**1.436,00**  
63 / 0,37

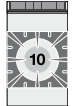

**PC2-78G**  
08210853

**PIANO COTTURA GAS SU MOBILE A GIORNO  
2 FUOCHI (INCLUSA 1 TESTATA CHIUSURA  
PIANO MOD.TPA-7)**

**EN** Gas heated boiling unit on open cabinet - 2 burners (included 1 Head end filler strip mod.TPA-7) • **DE** Gas-kochplatte mit offenem Unterbau - 2 Kochstellen (inbegriffen 1 Abschluss-Element mod.TPA-7) • **FR** Rechaud gaz sur armoire ouvert - 2 feux vifs (inclus 1 Élément de jonction top mod.TPA-7) • **ES** Sobres de cocción gas sobre mueble abierto - 2 quemadores (incluida 1 Chapa de cierre para top mod.TPA-7)  
**cm. 80x 70,5x 90h**



⚡ 17 kW  
14.620 kcal/h

**2.226,00**  
76 / 0,71

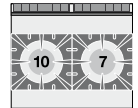

**PC3-712G**  
08211253

**PIANO COTTURA GAS SU MOBILE A GIORNO  
3 FUOCHI (INCLUSA 1 TESTATA CHIUSURA  
PIANO MOD.TPA-7)**

**EN** Gas heated boiling unit on open cabinet - 3 burners (included 1 Head end filler strip mod.TPA-7) • **DE** Gas-Kochplatte mit offenem Unterbau - 3 Kochstellen (inbegriffen 1 Abschluss-Element mod.TPA-7) • **FR** Rechaud gaz sur armoire ouvert - 3 feux vifs (inclus 1 Élément de jonction top mod.TPA-7) • **ES** Sobres de cocción gas sobre mueble abierto - 3 quemadores (incluida 1 Chapa de cierre para top mod.TPA-7)  
**cm. 120x 70,5x 90h**

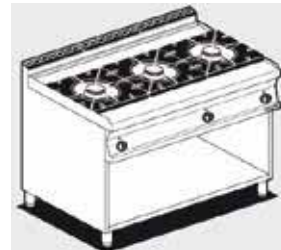

⚡ 27 kW  
23.220 kcal/h

**3.117,00**  
126 / 1,05

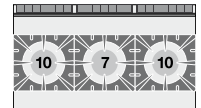

**PCA-74GP**  
08310450

**PIANO COTTURA ACQUA SU MOBILE A  
GIORNO 2 FUOCHI - RUBINETTO CARICO  
ACQUA, SFIORATORE (INCLUSA 1 TESTATA  
CHIUSURA PIANO MOD.TPA-7)**

**EN** water heated boiling unit on open cabinet - 2 burners - Water loading tap + overflow device (included 1 Head end filler strip mod.TPA-7) • **DE** wasser-Kochplatte mit offenem Unterbau - 2 Kochstellen - Wasserlauf-Hahn + Überlauf-Vorrichtung (inbegriffen 1 Abschluss-Element mod.TPA-7) • **FR** Rechaud l'eau sur armoire ouvert - 2 feux vifs - Robinet d'arrivée d'eau trop plein (inclus 1 Élément de jonction top mod.TPA-7) • **ES** Sobres de cocción agua sobre mueble abierto 2 quemadores - Grifo carga agua + vertedero (incluida 1 Chapa de cierre para top mod.TPA-7)  
**cm. 40x 70,5x 90h**



⚡ 14 kW  
12.040 kcal/h

**1.571,00**  
63 / 0,37

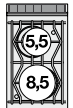

Le immagini presentate non sono vincolanti. La ditta si riserva di apportare modifiche senza preavviso. • The pictures are purely representative. The manufacturer reserves the right to modify the technical data and models without previous notice. • Les images

LO

présentées ne nous engagent pas. La Société se réserve le droit d'apporter tout modification sans préavis. • Die dargestellten Abbildungen sind nicht verbindlich. Technische Änderungen vorbehalten. • Las imágenes presentadas no son vinculantes. El Fabricante se reserva el derecho de modificar sus productos sin previo aviso.

01/20

127

70



# PIANI COTTURA AD ACQUA A GAS

MOD. \_\_\_\_\_  
COD. \_\_\_\_\_

DESCRIZIONE/DESCRIPTION/BEZEICHNUNG/DESCRIPTION/DESCRIPCIÓN  
DIMENSIONI/DIMENSIONS/ABMESSUNGEN/DIMENSIONS/DIMENSIONES

POTENZA/POWER/LEISTUNG/PUISSANCE/POTENCIA  
VOLTAGGIO/VOLTAGE/SPANNUNG/VOLTAGE/VOLTAJE

⚡ kW  
kcal/h

⚡ kW  
V~  
Hz

PREZZO/PRICE €  
PREIS/PRIX/PRECIO €  
KG / M<sup>3</sup>

**PCA-78GP**  
08310850

**PIANO COTTURA ACQUA SU MOBILE A GIORNO - 4 FUOCHI - RUBINETTO CARICO ACQUA, SFIORATORE (INCLUSA 1 TESTATA CHIUSURA PIANO MOD.TPA-7)**

**EN** water heated boiling unit on open cabinet - 4 burners - Water loading tap + overflow device (included 1 Head end filler strip mod.TPA-7) • **DE** wasser-kochplatte mit offenem Unterbau - 4 Kochstellen - Wasserlauf-Hahn + Überlauf-Vorrichtung (inbegriffen 1 Abschluss-Element mod.TPA-7) • **FR** Rechaud l'eau sur armoire ouvert - 4 feux vifs - Robinet d'arrivée d'eau trop plein (inclus 1 Élément de jonction top mod.TPA-7) • **ES** Sobres de cocción agua sobre mueble abierto 4 quemadores - Grifo carga agua + vertedero (incluida 1 Chapa de cierre para top mod.TPA-7)  
**cm. 80x 70,5x 90h**



⚡ 28 kW  
24.080 kcal/h

**3.090,00**  
76 / 0,71

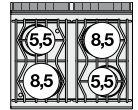

**PCA-712GP**  
08311250

**PIANO COTTURA ACQUA SU MOBILE A GIORNO 6 FUOCHI - RUBINETTO CARICO ACQUA, SFIORATORE (INCLUSA 1 TESTATA CHIUSURA PIANO MOD.TPA-7)**

**EN** water heated boiling unit on open cabinet - 6 burners - Water loading tap + overflow device (included 1 Head end filler strip mod.TPA-7) • **DE** wasser-kochplatte mit offenem Unterbau - 6 Kochstellen - Wasserlauf-Hahn + Überlauf-Vorrichtung (inbegriffen 1 Abschluss-Element mod.TPA-7) • **FR** Rechaud l'eau sur armoire ouvert - 6 feux vifs - Robinet d'arrivée d'eau trop plein (inclus 1 Élément de jonction top mod.TPA-7) • **ES** Sobres de cocción agua sobre mueble abierto 6 quemadores - Grifo carga agua + vertedero (incluida 1 Chapa de cierre para top mod.TPA-7)  
**cm. 120x 70,5x 90h**

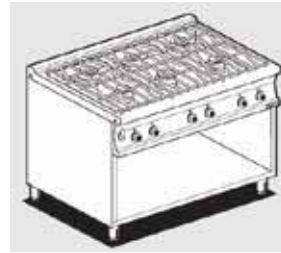

⚡ 42 kW  
36.120 kcal/h

**4.440,00**  
126 / 1,05

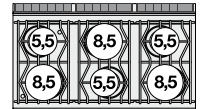

**PCW-74G**  
08210454

**PIANO COTTURA GAS "WOK" - SU MOBILE A GIORNO - 1 FUOCO - FIAMMA VERTICALE - ANELLO WOK (INCLUSA 1 TESTATA CHIUSURA PIANO MOD.TPA-7)**

**EN** Gas heated boiling "WOK" on open cabinet - 1 burner - vertical flame - Wok ring (included 1 Head end filler strip mod.TPA-7) • **DE** Gas-Kochplatte "WOK" mit offenem Unterbau - 1 Kochstellen - vertikaler Flamme - Wok Aufsatzring (inbegriffen 1 Abschluss-Element mod.TPA-7) • **FR** Rechaud gaz "WOK" sur armoire ouvert - 1 feux vifs - verticale de la flamme - Anneau Wok (inclus 1 Élément de jonction top mod.TPA-7) • **ES** Sobres de cocción gas "WOK" sobre mueble abierto - 1 quemador - llama vertical - Anillo Wok (incluida 1 Chapa de cierre para top mod.TPA-7)  
**cm. 40x 70,5x 90h**



⚡ 10 kW  
8.600 kcal/h

**1.784,00**  
66 / 0,37

**PA-78G**  
08210851

**"PAELLERO" GAS SU MOBILE A GIORNO (INCLUSA 1 TESTATA CHIUSURA PIANO MOD. TPA-7)**

**EN** "PAELLERO" Gas - open cabinet (included 1 Head end filler strip mod.TPA-7) • **DE** "PAELLERO" Gas mit offenem Unterbau (inbegriffen 1 Abschluss-Element mod.TPA-7) • **FR** "PAELLERO" gaz sur armoire ouvert (inclus 1 Élément de jonction top mod.TPA-7) • **ES** "PAELLERO" gas sobre mueble abierto (incluida 1 Chapa de cierre para top mod.TPA-7)  
**cm. 80x 70,5x 90h**



⚡ 11,5 kW  
9.890 kcal/h

**2.552,00**  
111 / 0,71



# PIANI COTTURA "PAELLERO" A GAS

MOD. \_\_\_\_\_  
COD. \_\_\_\_\_

DESCRIZIONE/DESCRIPTION/BEZEICHNUNG/DESCRIPTION/DESCRIPCIÓN  
DIMENSIONI/DIMENSIONS/ABMESSUNGEN/DIMENSIONS/DIMENSIONES

POTENZA/POWER/LEISTUNG/PUISSANCE/POTENCIA  
VOLTAGGIO/VOLTAGE/SPANNUNG/VOLTAGE/VOLTAJE

⚡ kW kcal/h  
⚡ kW kcal/h  
V~ Hz

PREZZO/PRICE €  
PREIS/PRIX/PRECIO €  
KG / M<sup>3</sup>

**PAF-78G**  
08680851

**"PAELLERO" GAS SU FORNO GAS STATICO**  
**CM. 67X55X34H, TEMP: 150÷300°C, CON**  
**1 GRIGLIA CM.65X53 GN2/1 (INCLUSA 1**  
**TESTATA CHIUSURA PIANO MOD.TPA-7)**  
**EN "PAELLERO" Gas on Traditional gas-oven cm.**  
67x55x34h, temp: 150÷300°C, with 1 grid cm.65x53  
GN2/1 (included 1 Head end filler strip mod.TPA-7) •  
**DE "PAELLERO" Gas mit Statischer Gas-Backofen cm.**  
67x55x34h, temp: 150÷300°C, mit 1 Rost cm.65x53  
GN2/1 (inbegriffen 1 Abschluss-Element mod.TPA-7)  
• **FR "PAELLERO" gaz sur Four à gaz statique cm.**  
67x55x34h, temp: 150÷300°C, avec 1 grille cm.65x53  
GN2/1 (inclus 1 Élément de jonction top mod.TPA-7)  
• **ES "PAELLERO" gas sobre Horno a gas estático cm.**  
67x55x34h, temp: 150÷300°C, con 1 parilla cm.65x53  
GN2/1 (incluida 1 Chapa de cierre para top mod.  
TPA-7)  
**cm. 80x 70,5x 90h**



⚡ 18,8 kW 3.178,00  
16.168 kcal/h 159 / 0,71

**TP-74G**  
08290450

**TUTTA PIASTRA SU MOBILE A GIORNO**  
**PIASTRA CM 37X57 (INCLUSA 1 TESTATA**  
**CHIUSURA PIANO MOD.TPA-7)**  
**EN Solid top on open unit - Plate 37x57cm (included**  
1 Head end filler strip mod.TPA-7) • **DE Kochplatte**  
auf offenem Unterbau - Platte 37x57 cm (inbegriffen 1  
Abschluss-Element mod.TPA-7) • **FR Toute plaque sur**  
meuble ouvert - Plaque cm 37x57 (inclus 1 Élément de  
jonction top mod.TPA-7) • **ES Placa de cocción sobre**  
mueble abierto - Placa cm 37x57 (incluida 1 Chapa de  
cierre para top mod.TPA-7)  
**cm. 40x 70,5x 90h**



⚡ 7 kW 1.709,00  
6.020 kcal/h 65 / 0,37

**TP-78G**  
08290850

**TUTTA PIASTRA SU MOBILE A GIORNO**  
**PIASTRA CM 77X57 (INCLUSA 1 TESTATA**  
**CHIUSURA PIANO MOD.TPA-7)**  
**EN Solid top on open unit - Plate 77x57cm (included**  
1 Head end filler strip mod.TPA-7) • **DE Kochplatte**  
auf offenem Unterbau - Platte 77x57 cm (inbegriffen 1  
Abschluss-Element mod.TPA-7) • **FR Toute plaque sur**  
meuble ouvert - Plaque cm 77x57 (inclus 1 Élément de  
jonction top mod.TPA-7) • **ES Placa de cocción sobre**  
mueble abierto - Placa cm 77x57 (incluida 1 Chapa de  
cierre para top mod.TPA-7)  
**cm. 80x 70,5x 90h**



⚡ 12 kW 2.324,00  
10.320 kcal/h 121 / 0,71

**TP2-78GP**  
08300850

**TUTTA PIASTRA + 2 FUOCHI SU MOBILE A**  
**GIORNO PIASTRA CM. 37X57 (INCLUSA 1**  
**TESTATA CHIUSURA PIANO MOD.TPA-7)**  
**EN Solid top + 2 burners on open unit Plate 37x57**  
(included 1 Head end filler strip mod.TPA-7) • **DE**  
Kochplatte + 2 Gaskochstellen auf offenem Unterbau  
Platte 37x57 (inbegriffen 1 Abschluss-Element mod.  
TPA-7) • **FR Toute plaque + 2 brûleurs sur meuble**  
ouvert Plaque cm. 37x57 (inclus 1 Élément de jonction  
top mod.TPA-7) • **ES Placa de cocción + 2 fuegos sobre**  
mueble abierto Placa cm. 37x57 (incluida 1 Chapa de  
cierre para top mod.TPA-7)  
**cm. 80x 70,5x 90h**



⚡ 20 kW 2.678,00  
17.200 kcal/h 115 / 0,71

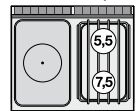

**TP2-712GP**  
08291250

**TUTTA PIASTRA + 2 FUOCHI SU MOBILE A**  
**GIORNO PIASTRA CM. 77X57 (INCLUSA 1**  
**TESTATA CHIUSURA PIANO MOD.TPA-7)**  
**EN Solid top + 2 burners on open unit Plate 77x57**  
(included 1 Head end filler strip mod.TPA-7) • **DE**  
Kochplatte + 2 Gaskochstellen auf offenem Unterbau  
Platte 77x57 (inbegriffen 1 Abschluss-Element mod.  
TPA-7) • **FR Toute plaque + 2 brûleurs sur meuble**  
ouvert Plaque cm. 77x57 (inclus 1 Élément de jonction  
top mod.TPA-7) • **ES Placa de cocción + 2 fuegos sobre**  
mueble abierto Placa cm. 77x57 (incluida 1 Chapa de  
cierre para top mod.TPA-7)  
**cm. 120x 70,5x 90h**



⚡ 25 kW 3.458,00  
21.500 kcal/h 157 / 1,05

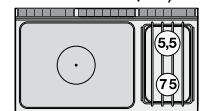

Le immagini presentate non sono vincolanti. La ditta si riserva di apportare modifiche senza preavviso. • The pictures are purely representative. The manufacturer reserves the right to modify the technical data and models without previous notice. • Les images

LO

présentées ne nous engagent pas. La Société se réserve le droit d'apporter tout modification sans préavis. • Die dargestellten Abbildungen sind nicht verbindlich. Technische Änderungen vorbehalten. • Las imágenes presentadas no son vinculantes. El Fabricante se reserva el derecho de modificar sus productos sin previo aviso.

01/20

129

70

# TUTTAPIASTRA A GAS

MOD. \_\_\_\_\_  
COD. \_\_\_\_\_

DESCRIZIONE/DESCRIPTION/BEZEICHNUNG/DESCRIPTION/DESCRIPCIÓN  
DIMENSIONI/DIMENSIONS/ABMESSUNGEN/DIMENSIONS/DIMENSIONES

POTENZA/POWER/LEISTUNG/PUISSANCE/POTENCIA  
VOLTAGGIO/VOLTAGE/SPANNUNG/VOLTAGE/VOLTAJE

⚡ kW kcal/h ⚡ kW kcal/h  
V~ Hz PREIS/PRIX/PRECIO €  
KG / M<sup>3</sup>

**TP4-712GP**  
08301250

**TUTTA PIASTRA + 4 FUOCHI SU MOBILE A GIORNO PIASTRA CM. 37X57 (INCLUSA 1 TESTATA CHIUSURA PIANO MOD.TPA-7)**

**EN** Solid top + 4 burners on open unit Plate 37x57 cm (included 1 Head end filler strip mod.TPA-7) • **DE** Kochplatte + 4 Gaskochstellen auf offenem Unterbau Platte 37x57 cm (inbegriffen 1 Abschluss-Element mod. TPA-7) • **FR** Toute plaque + 4 brûleurs sur meuble ouvert Plaque cm. 37x57 (inclus 1 Élément de jonction top mod.TPA-7) • **ES** Placa de cocción + 4 fuegos sobre mueble abierto Placa cm. 37x57 (incluida 1 Chapa de cierre para top mod.TPA-7)  
**cm. 120x 70,5x 90h**



⚡ 29 kW 24.940 kcal/h **3.558,00**  
154 / 1,05

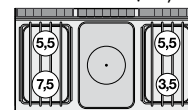

**TP-78ET**  
08120830

**TUTTA PIASTRA SU MOBILE A GIORNO PIASTRA CM. 70X50 - 4 ZONE (INCLUSA 1 TESTATA CHIUSURA PIANO MOD.TPA-7)**

**EN** Solid top on open unit - Plate cm. 70x50 - 4 zones (included 1 Head end filler strip mod.TPA-7) • **DE** Kochplatten auf offenem Unterbau - Platte cm. 70x50 - 4 zonen (inbegriffen 1 Abschluss-Element mod.TPA-7) • **FR** Toute plaque sur meuble ouvert - Plaque cm. 70x50 - 4 zones (inclus 1 Élément de jonction top mod.TPA-7) • **ES** Placa de cocción sobre mueble abierto - Placa cm. 70x50 - 4 zonas (incluida 1 Chapa de cierre para top mod.TPA-7)  
**cm. 80x 70,5x 90h**



⚡ 10 kW 400V~3N 50/60 Hz **2.863,00**  
121 / 0,71

**TPF-78ET**  
08670830

**TUTTA PIASTRA SU FORNO ELETTRICO STATICO CM. 67X55X34H, TEMP: 50÷300°C , CON 1 GRIGLIA CM.65X53 GN2/1 - PIASTRA CM. 70X50 4 ZONE (INCLUSA 1 TESTATA CHIUSURA PIANO MOD.TPA-7)**

**EN** Solid top on traditional electric oven cm. 67x55x34h, temp: 50÷300°C , with 1 grid cm.65x53 GN2/1 - Plate cm. 70x50 4 zones (included 1 Head end filler strip mod.TPA-7) • **DE** Kochplatten - Statischer Elektro-Backofen cm. 67x55x34h, temp: 50÷300°C , mit 1 Rost cm.65x53 GN2/1 - Platte cm. 70x50 4 zonen (inbegriffen 1 Abschluss-Element mod.TPA-7) • **FR** Toute plaque sur Four électrique statique cm. 67x55x34h, temp: 50÷300°C , avec 1 grille cm.65x53 GN2/1 - Plaque cm. 70x50 4 zones (inclus 1 Élément de jonction top mod.TPA-7) • **ES** Placa de cocción sobre Horno eléctrico estático cm. 67x55x34h, temp: 50÷300°C , con 1 parilla cm.65x53 GN2/1 - Placa cm. 70x50 4 zonas (incluida 1 Chapa de cierre para top mod.TPA-7)  
**cm. 80x 70,5x 90h**



⚡ 15 kW 400V~3N 50/60 Hz **4.024,00**  
170 / 0,71

**TPFV-78ET**  
08670835

**TUTTA PIASTRA SU FORNO ELETTRICO VENTILATO CM. 55X36X34H, TEMP: 50÷300°C , CON 1 GRIGLIA CM.53X32,5 GN1/1 - PIASTRA CM. 70X50 4 ZONE (INCLUSA 1 TESTATA CHIUSURA PIANO MOD. TPA-7)**

**EN** Solid top on electric fan oven cm. 55x36x34h, temp: 50÷300°C , with 1 grid cm.53x32,5 GN1/1 - Plate cm. 70x50 4 zones (included 1 Head end filler strip mod.TPA-7) • **DE** Kochplatten - Elektro-Heißluftofen cm. 55x36x34h, temp: 50÷300°C , mit 1 Rost cm.53x32,5 GN1/1 - Platte cm. 70x50 4 Zonen (inbegriffen 1 Abschluss-Element mod.TPA-7) • **FR** Toute plaque sur Four à chaleur tournante électrique cm. 55x36x34h, temp: 50÷300°C , avec 1 grille cm.53x32,5 GN1/1 - Plaque cm. 70x50 4 zones (inclus 1 Élément de jonction top mod.TPA-7) • **ES** Placa de cocción sobre Horno eléctrico ventilado cm. 55x36x34h, temp: 50÷300°C , con 1 parilla cm.53x32,5 GN1/1 - Placa cm. 70x50 4 zonas (incluida 1 Chapa de cierre para top mod.TPA-7)  
**cm. 80x 70,5x 90h**

⚡ 15,32 kW 400V~3N 50/60 Hz **4.335,00**  
170 / 0,71

# TUTTAPIASTRA A GAS CON FORNO

MOD. \_\_\_\_\_  
COD. \_\_\_\_\_

DESCRIZIONE/DESCRIPTION/BEZEICHNUNG/DESCRIPTION/DESCRIPCIÓN  
DIMENSIONI/DIMENSIONS/ABMESSUNGEN/DIMENSIONS/DIMENSIONES

POTENZA/POWER/LEISTUNG/PUISSANCE/POTENCIA  
VOLTAGGIO/VOLTAGE/SPANNUNG/VOLTAGE/VOLTAJE

⚡ kW  
kcal/h

⚡ kW  
V~  
Hz

PREZZO/PRICE €  
PREIS/PRIX/PRECIO €  
KG / M<sup>3</sup>

**TPF-78G**  
08700850

**TUTTA PIASTRA SU FORNO GAS STATICO**  
**CM. 67X55X34H, TEMP: 150÷300°C, CON**  
**1 GRIGLIA CM.65X53 GN2/1 - PIASTRA CM**  
**77X57 (INCLUSA 1 TESTATA CHIUSURA PIANO**  
**MOD.TPA-7)**

**EN** Solid top on Traditional gas-oven cm. 67x55x34h, temp: 150÷300°C, with 1 grid cm.65x53 GN2/1 - Plate cm. 77x57 (included 1 Head end filler strip mod. TPA-7) • **DE** Kochplatten - Statischer Gas-Backofen cm. 67x55x34h, temp: 150÷300°C, mit 1 Rost cm.65x53 GN2/1 - Platte cm. 77x57 (inbegriffen 1 Abschluss-Element mod.TPA-7) • **FR** Toute plaque sur Four à gaz statique cm. 67x55x34h, temp: 150÷300°C, avec 1 grille cm.65x53 GN2/1 - Plaque cm. 77x57 (inclus 1 Élément de jonction top mod.TPA-7) • **ES** Placa de cocción sobre Horno a gas estático cm. 67x55x34h, temp: 150÷300°C, con 1 parilla cm.65x53 GN2/1 - Placa cm. 77x57 (incluida 1 Chapa de cierre para top mod.TPA-7)

**cm. 80x 70,5x 90h**



⚡ 19,3 kW  
16.600 kcal/h

**3.585,00**  
169 / 0,71

**TPF-78GE**  
08710860

**TUTTA PIASTRA SU FORNO ELETTRICO STATICO**  
**CM. 67X55X34H, TEMP: 50÷300°C , CON 1**  
**GRIGLIA CM.65X53 GN2/1 - PIASTRA CM.**  
**77X57 (INCLUSA 1 TESTATA CHIUSURA PIANO**  
**MOD.TPA-7)**

**EN** Solid top on traditional electric oven cm. 67x55x34h, temp: 50÷300°C , with 1 grid cm.65x53 GN2/1 - Plate cm. 77x57 (included 1 Head end filler strip mod.TPA-7) • **DE** Kochplatten - Statischer Elektro-Backofen cm. 67x55x34h, temp: 50÷300°C , mit 1 Rost cm.65x53 GN2/1 - Platte cm. 77x57 (inbegriffen 1 Abschluss-Element mod.TPA-7) • **FR** Toute plaque sur Four électrique statique cm. 67x55x34h, temp: 50÷300°C , avec 1 grille cm.65x53 GN2/1 - Plaque cm. 77x57 (inclus 1 Élément de jonction top mod.TPA-7) • **ES** Placa de cocción sobre Horno eléctrico estático cm. 67x55x34h, temp: 50÷300°C , con 1 parilla cm.65x53 GN2/1 - Placa cm. 77x57 (incluida 1 Chapa de cierre para top mod.TPA-7)

**cm. 80x 70,5x 90h**



⚡ 12 kW  
10.320 kcal/h

**3.585,00**  
170 / 0,71

⚡ 5 kW  
400V~3N  
50/60 Hz

**TPFV-78GE**  
08710865

**TUTTA PIASTRA SU FORNO ELETTRICO**  
**VENTILATO CM. 55X36X34H, TEMP:**  
**50÷300°C , CON 1 GRIGLIA CM.53X32,5**  
**GN1/1 - PIASTRA CM. 77X57 (INCLUSA 1**  
**TESTATA CHIUSURA PIANO MOD.TPA-7)**

**EN** Solid top on electric fan oven cm. 55x36x34h, temp: 50÷300°C , with 1 grid cm.53x32,5 GN1/1 - Plate cm. 77x57 (included 1 Head end filler strip mod.TPA-7) • **DE** Kochplatten - Elektro-Heißluftofen cm. 55x36x34h, temp: 50÷300°C , mit 1 Rost cm.53x32,5 GN1/1 - Platte cm. 77x57 (inbegriffen 1 Abschluss-Element mod. TPA-7) • **FR** Toute plaque sur Four à chaleur tournante électrique cm. 55x36x34h, temp: 50÷300°C , avec 1 grille cm.53x32,5 GN1/1 - Plaque cm. 77x57 (inclus 1 Élément de jonction top mod.TPA-7) • **ES** Placa de cocción sobre Horno eléctrico ventilado cm. 55x36x34h, temp: 50÷300°C , con 1 parilla cm.53x32,5 GN1/1 - Placa cm. 77x57 (incluida 1 Chapa de cierre para top mod.TPA-7)

**cm. 80x 70,5x 90h**

⚡ 12 kW  
10.320 kcal/h

**3.911,00**  
170 / 0,71

⚡ 5,32 kW  
400V~3N  
230V~3  
50/60 Hz



Le immagini presentate non sono vincolanti. La ditta si riserva di apportare modifiche senza preavviso. • The pictures are purely representative. The manufacturer reserves the right to modify the technical data and models without previous notice. • Les images

LO

présentées ne nous engagent pas. La Société se réserve le droit d'apporter tout modification sans préavis. • Die dargestellten Abbildungen sind nicht verbindlich. Technische Änderungen vorbehalten. • Las imágenes presentadas no son vinculantes. El Fabricante se reserva el derecho de modificar sus productos sin previo aviso.

01/20

131

70

# TUTTAPIASTRA A GAS CON FORNO

MOD. \_\_\_\_\_  
COD. \_\_\_\_\_

DESCRIZIONE/DESCRIPTION/BEZEICHNUNG/DESCRIPTION/DESCRIPCIÓN  
DIMENSIONI/DIMENSIONS/ABMESSUNGEN/DIMENSIONS/DIMENSIONES

POTENZA/POWER/LEISTUNG/PUISSANCE/POTENCIA  
VOLTAGGIO/VOLTAGE/SPANNUNG/VOLTAGE/VOLTAJE

⚡ kW  
kcal/h

PREZZO/PRICE  
PREIS/PRIX/PRECIO  
KG / M<sup>3</sup>

TPF2-78GP  
08720850

**TUTTA PIASTRA + 2 FUOCHI SU FORNO GAS STATICO CM. 67X55X34H, TEMP: 150÷300°C, CON 1 GRIGLIA CM.65X53 GN2/1 - PIASTRA CM 37X57 (INCLUSA 1 TESTATA CHIUSURA PIANO MOD.TPA-7)**

**EN** Solid top + 2 burners traditional gas-oven cm. 67x55x34h, temp: 150÷300°C, with 1 grid cm.65x53 GN2/1 - Plate 37x57cm (included 1 Head end filler strip mod.TPA-7) • **DE** Kochplatte + 2 Gaskochstellen auf Statischer Gas-Backofen cm. 67x55x34h, temp: 150÷300°C, mit 1 Rost cm.65x53 GN2/1 - Platte 37x57 cm (inbegriffen 1 Abschluss-Element mod. TPA-7) • **FR** Toute plaque + 2 brûleurs sur Four à gaz statique cm. 67x55x34h, temp: 150÷300°C, avec 1 grille cm.65x53 GN2/1 - Plaque cm. 37x57 (inclus 1 Élément de jonction top mod.TPA-7) • **ES** Placa de cocción + 2 fuegos sobre Horno a gas estático cm. 67x55x34h, temp: 150÷300°C, con 1 parilla cm.65x53 GN2/1 - Placa cm 37x57 (incluida 1 Chapa de cierre para top mod.TPA-7)  
**cm. 80x 70,5x 90h**



⚡ 27,3 kW  
23.478 kcal/h

**3.850,00**  
165 / 0,71

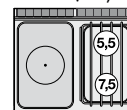

TPF2-78GPE  
08730860

**TUTTA PIASTRA + 2 FUOCHI SU FORNO ELETTRICO STATICO CM. 67X55X34H, TEMP: 50÷300°C , CON 1 GRIGLIA CM.65X53 GN2/1 - PIASTRA CM 37X57 (INCLUSA 1 TESTATA CHIUSURA PIANO MOD.TPA-7)**

**EN** Solid top + 2 burners traditional electric oven cm. 67x55x34h, temp: 50÷300°C , with 1 grid cm.65x53 GN2/1 - Plate 37x57cm (included 1 Head end filler strip mod.TPA-7) • **DE** Kochplatte + 2 Gaskochstellen auf Statischer Elektro-Backofen cm. 67x55x34h, temp: 50÷300°C , mit 1 Rost cm.65x53 GN2/1 - Platte 37x57 cm (inbegriffen 1 Abschluss-Element mod.TPA-7) • **FR** Toute plaque + 2 brûleurs sur Four électrique statique cm. 67x55x34h, temp: 50÷300°C , avec 1 grille cm.65x53 GN2/1 - Plaque cm. 37x57 (inclus 1 Élément de jonction top mod.TPA-7) • **ES** Placa de cocción + 2 fuegos sobre Horno eléctrico estático cm. 67x55x34h, temp: 50÷300°C , con 1 parilla cm.65x53 GN2/1 - Placa cm 37x57 (incluida 1 Chapa de cierre para top mod.TPA-7)  
**cm. 80x 70,5x 90h**



⚡ 20 kW  
17.200 kcal/h

**3.850,00**  
166 / 0,71

⚡ 5 kW  
400V~3N  
50/60 Hz

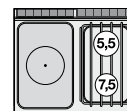

TPFV2-78GPE  
08730865

**TUTTA PIASTRA + 2 FUOCHI SU FORNO ELETTRICO VENTILATO CM. 55X36X34H, TEMP: 50÷300°C , CON 1 GRIGLIA CM.53X32,5 GN1/1 - PIASTRA CM 37X57 (INCLUSA 1 TESTATA CHIUSURA PIANO MOD. TPA-7)**

**EN** Solid top + 2 burners electric fan oven cm. 55x36x34h, temp: 50÷300°C , with 1 grid cm.53x32,5 GN1/1 - Plate 37x57cm (included 1 Head end filler strip mod.TPA-7) • **DE** Kochplatte + 2 Gaskochstellen auf Elektro-Heißluftofen cm. 55x36x34h, temp: 50÷300°C , mit 1 Rost cm.53x32,5 GN1/1 - Platte 37x57 cm (inbegriffen 1 Abschluss-Element mod.TPA-7) • **FR** Toute plaque + 2 brûleurs sur Four à chaleur tournante électrique cm. 55x36x34h, temp: 50÷300°C , avec 1 grille cm.53x32,5 GN1/1 - Plaque cm. 37x57 (inclus 1 Élément de jonction top mod.TPA-7) • **ES** Placa de cocción + 2 fuegos sobre Horno eléctrico ventilado cm. 55x36x34h, temp: 50÷300°C , con 1 parilla cm.53x32,5 GN1/1 - Placa cm 37x57 (incluida 1 Chapa de cierre para top mod.TPA-7)  
**cm. 80x 70,5x 90h**

⚡ 20 kW  
17.200 kcal/h

**4.167,00**  
166 / 0,71

⚡ 5,32 kW  
400V~3N  
230V~3  
50/60 Hz

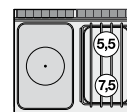



# TUTTAPIASTRA A GAS CON FORNO

MOD. \_\_\_\_\_  
COD. \_\_\_\_\_

DESCRIZIONE / DESCRIPTION / BEZEICHNUNG / DESCRIPTION / DESCRIPCIÓN  
DIMENSIONI / DIMENSIONS / ABMESSUNGEN / DIMENSIONS / DIMENSIONES

POTENZA / POWER / LEISTUNG / PUISSANCE / POTENCIA  
VOLTAGGIO / VOLTAGE / SPANNUNG / VOLTAGE / VOLTAJE

⚡ kW kcal/h ⚡ kw V~ Hz PREZZO / PRICE € PREIS / PRIX / PRECIO € KG / M<sup>3</sup>

**TPF2-712GPV TUTTA PIASTRA + 2 FUOCHI SU FORNO GAS STATICO CM. 67X55X34H, TEMP: 150÷300°C, CON 1 GRIGLIA CM.65X53 GN2/1 - PIASTRA CM 77X57 - VANO NEUTRO CON PORTA (INCLUSA 1 TESTATA CHIUSURA PIANO MOD. TPA-7)**

08701251

**EN** Solid top + 2 burners Traditional gas-oven cm. 67x55x34h, temp: 150÷300°C, with 1 grid cm.65x53 GN2/1 - Plate 77x57cm - Neutral cabinet with door (included 1 Head end filler strip mod.TPA-7) • **DE** Kochplatte + 2 Gaskochstellen auf Statischer Gas-Backofen cm. 67x55x34h, temp: 150÷300°C, mit 1 Rost cm.65x53 GN2/1 - Platte 77x57 cm - Neutrales Schrankelement mit Tür (inbegriffen 1 Abschluss-Element mod.TPA-7) • **FR** Toute plaque + 2 brûleurs sur Four à gaz statique cm. 67x55x34h, temp: 150÷300°C, avec 1 grille cm.65x53 GN2/1 - Plaque cm. 77x57 - Element neutre avec porte (inclus 1 Élément de jonction top mod.TPA-7) • **ES** Placa de cocción + 2 fuegos sobre Horno a gas estático cm. 67x55x34h, temp: 150÷300°C, con 1 parilla cm.65x53 GN2/1 - Placa cm 77x57 - Armario neutro con puerta (incluida 1 Chapa de cierre para top mod.TPA-7)

**cm. 120x 70,5x 90h**



⚡ 32,3 kW 4.935,00  
27.778 kcal/h 227 / 1,05

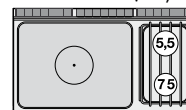

**TPF2-712GPEV TUTTA PIASTRA + 2 FUOCHI SU FORNO ELETTRICO STATICO CM. 67X55X34H, TEMP: 50÷300°C , CON 1 GRIGLIA CM.65X53 GN2/1 - PIASTRA CM 77X57 - VANO NEUTRO CON PORTA (INCLUSA 1 TESTATA CHIUSURA PIANO MOD.TPA-7)**

08711261

**EN** Solid top + 2 burners traditional electric oven cm. 67x55x34h, temp: 50÷300°C , with 1 grid cm.65x53 GN2/1 - Plate 77x57cm - Neutral cabinet with door (included 1 Head end filler strip mod.TPA-7) • **DE** Kochplatte + 2 Gaskochstellen auf Statischer Elektro-Backofen cm. 67x55x34h, temp: 50÷300°C , mit 1 Rost cm.65x53 GN2/1 - Platte 77x57 cm - Neutrales Schrankelement mit Tür (inbegriffen 1 Abschluss-Element mod.TPA-7) • **FR** Toute plaque + 2 brûleurs sur Four électrique statique cm. 67x55x34h, temp: 50÷300°C , avec 1 grille cm.65x53 GN2/1 - Plaque cm. 77x57 - Element neutre avec porte (inclus 1 Élément de jonction top mod.TPA-7) • **ES** Placa de cocción + 2 fuegos sobre Horno eléctrico estático cm. 67x55x34h, temp: 50÷300°C , con 1 parilla cm.65x53 GN2/1 - Placa cm 77x57 - Armario neutro con puerta (incluida 1 Chapa de cierre para top mod.TPA-7)

**cm. 120x 70,5x 90h**



⚡ 25 kW 4.935,00  
21.500 kcal/h 227 / 1,05

⚡ 5 kW  
400V~3N  
50/60 Hz

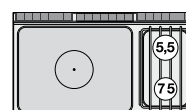

**TPFV2-712GPEV TUTTA PIASTRA + 2 FUOCHI SU FORNO ELETTRICO VENTILATO CM. 55X36X34H, TEMP: 50÷300°C , CON 1 GRIGLIA CM.53X32,5 GN1/1 - PIASTRA CM 77X57 - VANO NEUTRO CON PORTA (INCLUSA 1 TESTATA CHIUSURA PIANO MOD.TPA-7)**

08711266

**EN** Solid top + 2 burners electric fan oven cm. 55x36x34h, temp: 50÷300°C , with 1 grid cm.53x32,5 GN1/1 - Plate 77x57cm - Neutral cabinet with door (included 1 Head end filler strip mod.TPA-7) • **DE** Kochplatte + 2 Gaskochstellen auf Elektro-Heißluftofen cm. 55x36x34h, temp: 50÷300°C , mit 1 Rost cm.53x32,5 GN1/1 - Platte 77x57 cm - Neutrales Schrankelement mit Tür (inbegriffen 1 Abschluss-Element mod.TPA-7) • **FR** Toute plaque + 2 brûleurs sur Four à chaleur tournante électrique cm. 55x36x34h, temp: 50÷300°C , avec 1 grille cm.53x32,5 GN1/1 Plaque cm. 77x57 - Element neutre avec porte (inclus 1 Élément de jonction top mod.TPA-7) • **ES** Placa de cocción + 2 fuegos sobre Horno eléctrico ventilado cm. 55x36x34h, temp: 50÷300°C , con 1 parilla cm.53x32,5 GN1/1 - Placa cm 77x57 - Armario neutro con puerta (incluida 1 Chapa de cierre para top mod.TPA-7)

**cm. 120x 70,5x 90h**

⚡ 25 kW 5.260,00  
21.500 kcal/h 227 / 1,05

⚡ 5,32 kW  
400V~3N  
230V~3  
50/60 Hz

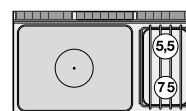

70



Le immagini presentate non sono vincolanti. La ditta si riserva di apportare modifiche senza preavviso. • The pictures are purely representative. The manufacturer reserves the right to modify the technical data and models without previous notice. • Les images

LO

présentées ne nous engagent pas. La Société se réserve le droit d'apporter tout modification sans préavis. • Die dargestellten Abbildungen sind nicht verbindlich. Technische Änderungen vorbehalten. • Las imágenes presentadas no son vinculantes. El Fabricante se reserva el derecho de modificar sus productos sin previo aviso.

01/20

133



# TUTTAPIASTRA A GAS CON FORNO

MOD. \_\_\_\_\_  
COD. \_\_\_\_\_

DESCRIZIONE/DESCRIPTION/BEZEICHNUNG/DESCRIPTION/DESCRIPCIÓN  
DIMENSIONI/DIMENSIONS/ABMESSUNGEN/DIMENSIONS/DIMENSIONES

POTENZA/POWER/LEISTUNG/PUISSANCE/POTENCIA  
VOLTAGGIO/VOLTAGE/SPANNUNG/VOLTAGE/VOLTAJE

⚡ kW  
kcal/h  
V~  
Hz

PREZZO/PRICE €  
PREIS/PRIX/PRECIO €  
KG / M<sup>3</sup>

**TPF2-712GP TUTTA PIASTRA + 2 FUOCHI SU FORNO**  
08701250 **GAS STATICO CM. 107X55X34H, TEMP: 150÷300°C, CON 1 GRIGLIA CM.105X53 - PIASTRA CM 77X57 (INCLUSA 1 TESTATA CHIUSURA PIANO MOD.TPA-7)**

**EN** Solid top + 2 burners Traditional gas-oven cm. 107x55x34h, temp: 150÷300°C, with 1 grid cm.105x53 - Plate 77x57 (included 1 Head end filler strip mod.TPA-7) • **DE** Kochplatte + 2 Gaskochstellen auf Statischer Gas-Backofen cm. 107x55x34h, temp: 150÷300°C, mit 1 Rost cm.105x53 - Platte 77x57 (inbegriffen 1 Abschluss-Element mod.TPA-7) • **FR** Toute plaque + 2 brûleurs sur Four à gaz statique cm. 107x55x34h, temp: 150÷300°C, avec 1 grille cm.105x53 - Plaque cm. 77x57 (inclus 1 Elément de jonction top mod.TPA-7) • **ES** Placa de cocción + 2 fuegos sobre Horno a gas estático cm. 107x55x34h, temp: 150÷300°C, con 1 parilla cm.105x53 - Placa cm 77x57 (incluida 1 Chapa de cierre para top mod. TPA-7)

**cm. 120x 70,5x 90h**



⚡ 36 kW **5.291,00**  
30.960 kcal/h 209 / 1,05

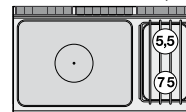

**TPF2-712GPE TUTTA PIASTRA + 2 FUOCHI SU FORNO**  
08711260 **ELETTRICO STATICO CM. 107X55X34H, TEMP: 50÷300°C, CON 1 GRIGLIA CM.105X53 - PIASTRA CM 77X57 (INCLUSA 1 TESTATA CHIUSURA PIANO MOD.TPA-7)**

**EN** Solid top + 2 burners traditional electric oven cm. 107x55x34h, temp: 50÷300°C, with 1 grid cm.105x53 - Plate 77x57 (included 1 Head end filler strip mod.TPA-7) • **DE** Kochplatte + 2 Gaskochstellen auf Statischer Elektro-Backofen cm. 107x55x34h, temp: 50÷300°C, mit 1 Rost cm.105x53 - Platte 77x57 (inbegriffen 1 Abschluss-Element mod.TPA-7) • **FR** Toute plaque + 2 brûleurs sur Four électrique statique cm. 107x55x34h, temp: 50÷300°C, avec 1 grille cm.105x53 - Plaque cm. 77x57 (inclus 1 Elément de jonction top mod.TPA-7) • **ES** Placa de cocción + 2 fuegos sobre Horno eléctrico estático cm. 107x55x34h, temp: 50÷300°C, con 1 parilla cm.105x53 - Placa cm 77x57 (incluida 1 Chapa de cierre para top mod.TPA-7)

**cm. 120x 70,5x 90h**



⚡ 25 kW **5.291,00**  
21.500 kcal/h 209 / 1,05

⚡ 6,9 kW  
400V~3N  
50/60 Hz

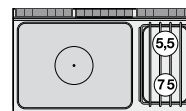

**TPF4-712GPV TUTTA PIASTRA + 4 FUOCHI SU FORNO GAS**  
08721251 **STATICO CM. 67X55X34H, TEMP: 150÷300°C, CON 1 GRIGLIA CM.65X53 GN2/1 - PIASTRA CM 37X57 - VANO NEUTRO CON PORTA (INCLUSA 1 TESTATA CHIUSURA PIANO MOD. TPA-7)**

**EN** Solid top + 4 burners Traditional gas-oven cm. 67x55x34h, temp: 150÷300°C, with 1 grid cm.65x53 GN2/1 - Plate 37x57cm - Neutral cabinet with door (included 1 Head end filler strip mod.TPA-7) • **DE** Kochplatte + 4 Gaskochstellen auf Statischer Gas-Backofen cm. 67x55x34h, temp: 150÷300°C, mit 1 Rost cm.65x53 GN2/1 - Platte 37x57 cm - Neutrales Schrankelement mit Tür (inbegriffen 1 Abschluss-Element mod.TPA-7) • **FR** Toute plaque + 4 brûleurs sur Four à gaz statique cm. 67x55x34h, temp: 150÷300°C, avec 1 grille cm.65x53 GN2/1 - Plaque cm. 37x57 - Element neutre avec porte (inclus 1 Elément de jonction top mod. TPA-7) • **ES** Placa de cocción + 4 fuegos sobre Horno a gas estático cm. 67x55x34h, temp: 150÷300°C, con 1 parilla cm.65x53 GN2/1 - Placa cm 37x57 - Armario neutro con puerta (incluida 1 Chapa de cierre para top mod.TPA-7)

**cm. 120x 70,5x 90h**



⚡ 36,3 kW **4.933,00**  
31.218 kcal/h 221 / 1,05

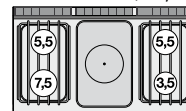

# TUTTAPIASTRA A GAS CON FORNO ELETTRICO

MOD. \_\_\_\_\_  
COD. \_\_\_\_\_

DESCRIZIONE/DESCRIPTION/BEZEICHNUNG/DESCRIPTION/DESCRIPCIÓN  
DIMENSIONI/DIMENSIONS/ABMESSUNGEN/DIMENSIONS/DIMENSIONES

POTENZA/POWER/LEISTUNG/PUISSANCE/POTENCIA  
VOLTAGGIO/VOLTAGE/SPANNUNG/VOLTAGE/VOLTAJE

⚡ kW  
kcal/h

⚡ kW  
V~  
Hz

PREZZO/PRICE €  
PREIS/PRIX/PRECIO €  
KG / M<sup>3</sup>

**TPF4-712GPEV TUTTA PIASTRA + 4 FUOCHI SU FORNO  
ELETTRICO STATICO CM. 67X55X34H, TEMP:  
50÷300°C, CON 1 GRIGLIA CM.65X53  
GN2/1 - PIASTRA CM 37X57 - VANO NEUTRO  
CON PORTA (INCLUSA 1 TESTATA CHIUSURA  
PIANO MOD.TPA-7)**

**EN** Solid top + 4 burners traditional electric oven cm. 67x55x34h, temp: 50÷300°C, with 1 grid cm.65x53 GN2/1 - Plate 37x57cm - Neutral cabinet with door (included 1 Head end filler strip mod.TPA-7) • **DE** Kochplatte + 4 Gaskochstellen auf Statischer Elektro-Backofen cm. 67x55x34h, temp: 50÷300°C, mit 1 Rost cm.65x53 GN2/1 - Platte 37x57 cm - Neutrales Schrankelement mit Tür (inbegriffen 1 Abschluss-Element mod.TPA-7) • **FR** Toute plaque + 4 brûleurs sur Four électrique statique cm. 67x55x34h, temp: 50÷300°C, avec 1 grille cm.65x53 GN2/1 - Plaque cm. 37x57 - Element neutre avec porte (inclus 1 Elément de jonction top mod.TPA-7) • **ES** Placa de cocción + 4 fuegos sobre Horno eléctrico estático cm. 67x55x34h, temp: 50÷300°C, con 1 parilla cm.65x53 GN2/1 - Placa cm 37x57 - Armario neutro con puerta (incluida 1 Chapa de cierre para top mod.TPA-7)  
**cm. 120x 70,5x 90h**



⚡ 29 kW  
24.940 kcal/h

**4.933,00**  
221 / 1,05

⚡ 5 kW  
400V~3N  
50/60 Hz

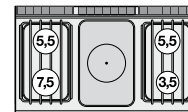

**TPFV4-712GPEV TUTTA PIASTRA + 4 FUOCHI SU FORNO  
ELETTRICO VENTILATO CM. 55X36X34H,  
TEMP: 50÷300°C, CON 1 GRIGLIA  
CM.53X32,5 GN1/1 - PIASTRA CM 37X57  
- VANO NEUTRO CON PORTA (INCLUSA 1  
TESTATA CHIUSURA PIANO MOD.TPA-7)**

**EN** Solid top + 4 burners electric fan oven cm. 55x36x34h, temp: 50÷300°C, with 1 grid cm.53x32,5 GN1/1 - Plate 37x57cm - Neutral cabinet with door (included 1 Head end filler strip mod.TPA-7) • **DE** Kochplatte + 4 Gaskochstellen auf Elektro-Heißluftofen cm. 55x36x34h, temp: 50÷300°C, mit 1 Rost cm.53x32,5 GN1/1 - Platte 37x57 cm - Neutrales Schrankelement mit Tür (inbegriffen 1 Abschluss-Element mod.TPA-7) • **FR** Toute plaque + 4 brûleurs sur Four à chaleur tournante électrique cm. 55x36x34h, temp: 50÷300°C, avec 1 grille cm.53x32,5 GN1/1 - Plaque cm. 37x57 - Element neutre avec porte (inclus 1 Elément de jonction top mod.TPA-7) • **ES** Placa de cocción + 4 fuegos sobre Horno eléctrico ventilado cm. 55x36x34h, temp: 50÷300°C, con 1 parilla cm.53x32,5 GN1/1 - Placa cm 37x57 - Armario neutro con puerta (incluida 1 Chapa de cierre para top mod.TPA-7)  
**cm. 120x 70,5x 90h**

⚡ 29 kW  
24.940 kcal/h

**5.250,00**  
221 / 1,05

⚡ 5,32 kW  
400V~3N  
230V~3  
50/60 Hz

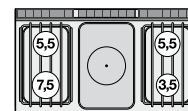

**TPF4-712GP TUTTA PIASTRA + 4 FUOCHI SU FORNO  
GAS STATICO CM. 107X55X34H, TEMP:  
150÷300°C, CON 1 GRIGLIA CM.105X53 -  
PIASTRA CM 37X57 (INCLUSA 1 TESTATA  
CHIUSURA PIANO MOD.TPA-7)**

**EN** Solid top + 4 burners Traditional gas-oven cm. 107x55x34h, temp: 150÷300°C, with 1 grid cm.105x53 - Plate 37x57cm (included 1 Head end filler strip mod.TPA-7) • **DE** Kochplatte + 4 Gaskochstellen auf Statischer Gas-Backofen cm. 107x55x34h, temp: 150÷300°C, mit 1 Rost cm.105x53 - Platte 37x57 cm (inbegriffen 1 Abschluss-Element mod.TPA-7) • **FR** Toute plaque + 4 brûleurs sur Four à gaz statique cm. 107x55x34h, temp: 150÷300°C, avec 1 grille cm.105x53 Plaque cm. 37x57 (inclus 1 Elément de jonction top mod.TPA-7) • **ES** Placa de cocción + 4 fuegos sobre Horno a gas estático cm. 107x55x34h, temp: 150÷300°C, con 1 parilla cm.105x53 - Placa cm 37x57 (incluida 1 Chapa de cierre para top mod.TPA-7)  
**cm. 120x 70,5x 90h**



⚡ 40 kW  
34.400 kcal/h

**5.534,00**  
202 / 1,05

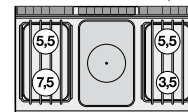

# TUTTAPIASTRA A GAS CON FORNO ELETTRICO

MOD. \_\_\_\_\_  
COD. \_\_\_\_\_

DESCRIZIONE/DESCRIPTION/BEZEICHNUNG/DESCRIPTION/DESCRIPCIÓN  
DIMENSIONI/DIMENSIONS/ABMESSUNGEN/DIMENSIONS/DIMENSIONES

POTENZA/POWER/LEISTUNG/PUISSANCE/POTENCIA  
VOLTAGGIO/VOLTAGE/SPANNUNG/VOLTAGE/VOLTAJE

⚡ kW \_\_\_\_\_ kcal/h \_\_\_\_\_  
⚡ kW \_\_\_\_\_ V~ \_\_\_\_\_ Hz \_\_\_\_\_  
PREZZO/PRICE € \_\_\_\_\_  
PREIS/PRIX/PRECIO € \_\_\_\_\_  
KG / M<sup>3</sup> \_\_\_\_\_

**TPF4-712GPE TUTTA PIASTRA + 4 FUOCHI SU FORNO  
ELETTRICO STATICO CM. 107X55X34H, TEMP:  
50÷300°C , CON 1 GRIGLIA CM.105X53 -  
PIASTRA CM 37X57 (INCLUSA 1 TESTATA  
CHIUSURA PIANO MOD.TPA-7)**

**EN** Solid top + 4 burners traditional electric oven cm. 107x55x34h, temp: 50÷300°C , with 1 grid cm.105x53 - Plate 37x57cm (included 1 Head end filler strip mod.TPA-7) • **DE** Kochplatte + 4 Gaskochstellen auf Statischer Elektro-Backofen cm. 107x55x34h, temp: 50÷300°C , mit 1 Rost cm.105x53 - Platte 37x57 cm (inbegriffen 1 Abschluss-Element mod.TPA-7) • **FR** Toute plaque + 4 brûleurs sur Four électrique statique cm. 107x55x34h, temp: 50÷300°C , avec 1 grille cm.105x53 - Plaque cm. 37x57 (inclus 1 Élément de jonction top mod.TPA-7) • **ES** Placa de cocción + 4 fuegos sobre Horno eléctrico estático cm. 107x55x34h, temp: 50÷300°C , con 1 parilla cm.105x53 - Placa cm 37x57 (incluida 1 Chapa de cierre para top mod.TPA-7)  
**cm. 120x 70,5x 90h**



⚡ 29 kW \_\_\_\_\_ **5.534,00**  
24.940 kcal/h \_\_\_\_\_ 202 / 1,05

⚡ 6,9 kW \_\_\_\_\_  
400V~3N \_\_\_\_\_  
50/60 Hz \_\_\_\_\_

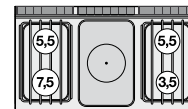

**BM-74EM BAGNOMARIA MONOFASE SU MOBILE  
A GIORNO VASCA PER GN 1/1 H.15,  
RUBINETTO CARICO ACQUA, SCARICO A  
PAVIMENTO (INCLUSA 1 TESTATA CHIUSURA  
PIANO MOD.TPA-7)**

**EN** Bain marie singlephase on open cabinet - Bowl for GN 1/1 h.15, water loading cock, floor draining (included 1 Head end filler strip mod.TPA-7) • **DE** Wasserbäder einphasig mit offenem Unterbau - Becken GN 1/1 h.15, Wasserlauf-Hahn, Ablauf am Boden (inbegriffen 1 Abschluss-Element mod.TPA-7) • **FR** Bain marie monophase sur armoire ouvert - Cuve GN 1/1 h.15 - Robinet d'arrivée d'eau, système de vidange au sol (inclus 1 Élément de jonction top mod.TPA-7) • **ES** Baño de maría monofásico sobre mueble abierto Cuba para GN 1/1 15h - Grifo carga agua, descarga a pavimento (incluida 1 Chapa de cierre para top mod.TPA-7)  
**cm. 40x 70,5x 90h**



⚡ 2,1 kW \_\_\_\_\_ **1.359,00**  
230V~ \_\_\_\_\_ 41 / 0,37  
50/60 Hz \_\_\_\_\_

**BM-78ET BAGNOMARIA TRIFASE SU MOBILE A GIORNO  
VASCA PER GN 2/1 15H, RUBINETTO CARICO  
ACQUA, SCARICO A PAVIMENTO (INCLUSA 1  
TESTATA CHIUSURA PIANO MOD.TPA-7)**

**EN** Bain marie threephase on open cabinet - Bowl for GN 2/1 15h, water loading cock, floor draining (included 1 Head end filler strip mod.TPA-7) • **DE** Wasserbäder Dreiphasig mit offenem Unterbau - Becken GN 2/1 15h, Wasserlauf-Hahn, Ablauf am Boden (inbegriffen 1 Abschluss-Element mod.TPA-7) • **FR** Bain marie triphase sur armoire ouvert Cuve GN 2/1 15h, Robinet d'arrivée d'eau, système de vidange au sol (inclus 1 Élément de jonction top mod.TPA-7) • **ES** Baño de maría trifásico. sobre mueble abierto Cuba para GN 2/1 15h, grifo carga agua, descarga a pavimento (incluida 1 Chapa de cierre para top mod.TPA-7)  
**cm. 80x 70,5x 90h**



⚡ 4,2 kW \_\_\_\_\_ **1.922,00**  
400V~2N \_\_\_\_\_ 61 / 0,71  
230V~3 \_\_\_\_\_  
50/60 Hz \_\_\_\_\_

# BAGNOMARIA A GAS

MOD. \_\_\_\_\_  
COD. \_\_\_\_\_

DESCRIZIONE/DESCRIPTION/BEZEICHNUNG/DESCRIPTION/DESCRIPCIÓN  
DIMENSIONI/DIMENSIONS/ABMESSUNGEN/DIMENSIONS/DIMENSIONES

POTENZA/POWER/LEISTUNG/PUISSANCE/POTENCIA  
VOLTAGGIO/VOLTAGE/SPANNUNG/VOLTAGE/VOLTAJE

⚡ kW  
kcal/h

⚡ kW  
V~  
Hz

PREZZO/PRICE €  
PREIS/PRIX/PRECIO €  
KG / M<sup>3</sup>

**BM-74G**  
08220450

**BAGNOMARIA GAS SU MOBILE A GIORNO  
VASCA PER GN 1/1 H.15, RUBINETTO CARICO  
ACQUA, SCARICO A PAVIMENTO (INCLUSA 1  
TESTATA CHIUSURA PIANO MOD.TPA-7)**

**EN** Gas bain marie on open cabinet - Bowl for GN 1/1 h.15, water loading cock, floor draining (included 1 Head end filler strip mod.TPA-7) • **DE** Gas Wasserbad mit offenem Unterbau - Becken GN 1/1 h.15, Wasserlauf-Hahn, Ablauf am Boden (inbegriffen 1 Abschluss-Element mod.TPA-7) • **FR** Bain-marie gaz sur armoire ouvert Cuve pour GN 1/1 h.15 - Robinet d'arrivée d'eau, système de vidange au sol (inclus 1 Élément de jonction top mod.TPA-7) • **ES** Baño de maría gas sobre mueble abierto - Cuba para GN 1/1 15h, grifo carga agua, descarga a pavimento (incluida 1 Chapa de cierre para top mod.TPA-7)  
**cm. 40x 70,5x 90h**



⚡ 3,5 kW  
3.010 kcal/h

**1.504,00**  
49 / 0,37

**BM-78G**  
08220850

**BAGNOMARIA GAS SU MOBILE A GIORNO  
VASCA PER GN 2/1 H.15, RUBINETTO CARICO  
ACQUA, SCARICO A PAVIMENTO. (INCLUSA 1  
TESTATA CHIUSURA PIANO MOD.TPA-7)**

**EN** Gas ain marie on open cabinet. Bowl for GN 2/1 h.15, water loading cock, floor draining (included 1 Head end filler strip mod.TPA-7) • **DE** Gas Wasserbad mit offenem Unterbau. Becken GN 2/1 h.15, Wasserlauf-Hahn, Ablauf am Boden. (inbegriffen 1 Abschluss-Element mod.TPA-7) • **FR** Bain-marie gaz sur armoire ouvert. Cuve pour GN 2/1 h.15, robinet d'arrivée d'eau, système de vidange au sol (inclus 1 Élément de jonction top mod.TPA-7) • **ES** Baño de maría gas sobre mueble abierto. Cuba para GN 2/1 15h, grifo carga agua, descarga a pavimento. (incluida 1 Chapa de cierre para top mod.TPA-7)  
**cm. 80x 70,5x 90h**



⚡ 6,5 kW  
5.590 kcal/h

**2.397,00**  
68 / 0,71

**BS-74EM**  
08040410

**CONTENITORE CALDO CON INFRAROSSO,  
MONOFASE SU MOBILE A GIORNO VASCA  
CM. 30,5X51X16,5H CON FALSO FONDO  
FORATO (INCLUSA 1 TESTATA CHIUSURA  
PIANO MOD.TPA-7)**

**EN** Fry dump singlephase with infra-red heater on open cabinet. Bowl cm. 30,5x51x16,5h with perforated double bottom (included 1 Head end filler strip mod.TPA-7) • **DE** Frittenwanne Einphasig mit Infrarot-strahler mit offenem Unterbau. Becke cm. 30,5x51x16,5h mit gelochtem Bodenrost (inbegriffen 1 Abschluss-Element mod.TPA-7) • **FR** Silo a frites monophasé avec infrarouge sur armoire ouvert. Cuve cm 30,5x51x16,5h avec double-fond perforé. (inclus 1 Élément de jonction top mod.TPA-7) • **ES** Contenedor caliente por infrarrojo, monofásico y sobre mueble abierto. Cuba cm. 30,5x51x16,5h con falso fondo agujereado (incluida 1 Chapa de cierre para top mod.TPA-7)  
**cm. 40x 70,5x 90h**



⚡ 1,47 kW  
230V~  
50/60 Hz

**1.713,00**  
42 / 0,40



Le immagini presentate non sono vincolanti. La ditta si riserva di apportare modifiche senza preavviso. • The pictures are purely representative. The manufacturer reserves the right to modify the technical data and models without previous notice. • Les images

**LO**

présentées ne nous engagent pas. La Société se réserve le droit d'apporter tout modification sans préavis. • Die dargestellten Abbildungen sind nicht verbindlich. Technische Änderungen vorbehalten. • Las imágenes presentadas no son vinculantes. El Fabricante se reserva el derecho de modificar sus productos sin previo aviso.

01/20

**137**

MOD. \_\_\_\_\_  
COD. \_\_\_\_\_

DESCRIZIONE/DESCRIPTION/BEZEICHNUNG/DESCRIPTION/DESCRIPCIÓN  
DIMENSIONI/DIMENSIONS/ABMESSUNGEN/DIMENSIONS/DIMENSIONES

POTENZA/POWER/LEISTUNG/PUISSANCE/POTENCIA  
VOLTAGGIO/VOLTAGE/SPANNUNG/VOLTAGE/VOLTAJE

⚡ kW kcal/h  
⚡ kW V~ Hz

PREZZO/PRICE €  
PREIS/PRIX/PRECIO €  
KG / M<sup>3</sup>

**CP-74ET**  
08100430

**CUOCIPASTA TRIFASE LT. 25 VASCA CM. 30,5X33,5X32,7H. RUBINETTO CARICO ACQUA, SFIORATORE + SCARICO A PAVIMENTO. (CESTI ESCLUSI) (INCLUSA 1 TESTATA CHIUSURA PIANO MOD.TPA-7)**  
**EN** Pasta cooker threephase 25 lts. Tank cm. 30,5x33,5x32,7h. Water loading cock + overflow device and floor draining (BASKETS EXCLUDED) (included 1 Head end filler strip mod.TPA-7) • **DE** Nudelkocher Dreiphasig lt. 25. Becken cm. 30,5x33,5x32,7h. Wasserlauf-Hahn, + Überlauf-Vorrichtung und Ablauf am Boden (KORB AUSGESCHLOSSEN) (inbegriffen 1 Abschluss-Element mod.TPA-7) • **FR** Cuiseur à pates triphase lt. 25. Cuve cm.30,5x33,5x32,7h. Robinet d'arrivée d'eau trop plein + système de vidange au sol (PANIERS EXCLUS) (inclus 1 Élément de jonction top mod.TPA-7) • **ES** Cuece pasta trifásico. 25 lt. Cuba cm. 30,5x33,5x32,7h. Grifo carga agua + vertedero + descarga a pavimento (CESTAS EXCLUIDAS) (incluida 1 Chapa de cierre para top mod. TPA-7)  
**cm. 40x 70,5x 90h**



⚡ 7,8 kW **2.487,00**  
400V~3N 48 / 0,37  
50/60 Hz

### COMBINAZIONI

- Combinations / • Zusammenstellungen
- Combinaisons / • Combinación múltiple



**CPA-74ET**  
08100435

**CUOCIPASTA TRIFASE LT. 25 VASCA CM. 30,5X33,5X32,7H. CARICO ACQUA AUTOMATICO CON SENSORE DI LIVELLO - SFIORATORE + SCARICO A PAVIMENTO (CESTI ESCLUSI) (INCLUSA 1 TESTATA CHIUSURA PIANO MOD.TPA-7)**  
**EN** Pasta cooker threephase 25 lts. Tank cm. 30,5x33,5x32,7h. Automatic Water loading with level sensor - overflow device and floor draining (BASKETS EXCLUDED) (included 1 Head end filler strip mod. TPA-7) • **DE** Nudelkocher Dreiphasig lt. 25. Becken cm. 30,5x33,5x32,7h. Automatische Wasser Beladung mit Niveauregulierung + Überlauf-Vorrichtung und Ablauf am Boden (KORB AUSGESCHLOSSEN) (inbegriffen 1 Abschluss-Element mod.TPA-7) • **FR** Cuiseur à pates triphase lt. 25. Cuve cm.30,5x33,5x32,7h. Chargement automatique de l'eau avec sensor de niveau, trop plein Système de vidange au sol (PANIERS EXCLUS) (inclus 1 Élément de jonction top mod.TPA-7) • **ES** Cuece pasta trifásico. 25 lt. Cuba cm. 30,5x33,5x32,7h. Carga automática de agua con sensor de nivel + vertedero + descarga a pavimento. (CESTAS EXCLUIDAS) (incluida 1 Chapa de cierre para top mod.TPA-7)  
**cm. 40x 70,5x 90h**



⚡ 7,8 kW **2.873,00**  
400V~3N 48 / 0,37  
50/60 Hz

### COMBINAZIONI

- Combinations / • Zusammenstellungen
- Combinaisons / • Combinación múltiple





MOD. \_\_\_\_\_  
COD. \_\_\_\_\_

DESCRIZIONE/DESCRIPTION/BEZEICHNUNG/DESCRIPTION/DESCRIPCIÓN  
DIMENSIONI/DIMENSIONS/ABMESSUNGEN/DIMENSIONS/DIMENSIONES

POTENZA/POWER/LEISTUNG/PUISSANCE/POTENCIA  
VOLTAGGIO/VOLTAGE/SPANNUNG/VOLTAGE/VOLTAJE

⚡ kW kcal/h  
⚡ kW V~ Hz

PREZZO/PRICE €  
PREIS/PRIX/PRECIO €  
KG / M<sup>3</sup>

**CP-76ET**  
08100630

**CUOCIPASTA TRIFASE LT. 40 VASCA CM. 51X30,7X32,7H. RUBINETTO CARICO ACQUA, SFIORATORE + SCARICO A PAVIMENTO. (CESTI ESCLUSI) (INCLUSA 1 TESTATA CHIUSURA PIANO MOD.TPA-7)**

**EN** Pasta cooker threephase 40 lts. Tank cm. 51x30,7x32,7h. Water loading cock + overflow device and floor draining (BASKETS EXCLUDED) (included 1 Head end filler strip mod.TPA-7) • **DE** Nudelkocher Dreiphasig lt. 40. Becken cm. 51x30,7x32,7h. Wasserlauf-Hahn, + Überlauf-Vorrichtung und Ablauf am Boden (KORB AUSGESCHLOSSEN) (inbegriffen 1 Abschluss-Element mod.TPA-7) • **FR** Cuiseur à pâtes triphase lt. 40. Cuve cm.51x30,7x32,7h. Robinet d'arrivée d'eau trop plein + système de vidange au sol (PANIERS EXCLUS) (inclus 1 Élément de jonction top mod.TPA-7) • **ES** Cuece pasta trifásico 40 lt. Cuba cm. 51x30,7x32,7h. Grifo carga agua + vertedero + descarga a pavimento (CESTAS EXCLUIDAS) (incluida 1 Chapa de cierre para top mod.TPA-7)  
**cm. 60x 70,5x 90h**



⚡ 13,5 kW **3.139,00**  
400V~3N 78 / 0,54  
50/60 Hz

### COMBINAZIONI

- Combinations / • Zusammenstellungen
- Combinaisons / • Combinación múltiple



**CPA-76ET**  
08100635

**CUOCIPASTA TRIFASE LT. 40 VASCA CM. 51X30,7X32,7H. CARICO ACQUA AUTOMATICO CON SENSORE DI LIVELLO - SFIORATORE + SCARICO A PAVIMENTO (CESTI ESCLUSI) (INCLUSA 1 TESTATA CHIUSURA PIANO MOD.TPA-7)**

**EN** Pasta cooker threephase 40 lts. Tank cm. 51x30,7x32,7h. Automatic Water loading with level sensor - overflow device and floor draining (BASKETS EXCLUDED) (included 1 Head end filler strip mod.TPA-7) • **DE** Nudelkocher Dreiphasig lt. 40. Becken cm. 51x30,7x32,7h. Automatische Wasser Beladung mit Niveauregulierung + Überlauf-Vorrichtung und Ablauf am Boden (KORB AUSGESCHLOSSEN) (inbegriffen 1 Abschluss-Element mod.TPA-7) • **FR** Cuiseur à pâtes triphase lt. 40. Cuve cm.51x30,7x32,7h. Chargement automatique de l'eau avec sensor de niveau, trop plein Système de vidange au sol (PANIERS EXCLUS) (inclus 1 Élément de jonction top mod.TPA-7) • **ES** Cuece pasta trifásico 40 lt. Cuba cm. 51x30,7x32,7h. Carga automática de agua con sensor de nivel + vertedero + descarga a pavimento. (CESTAS EXCLUIDAS) (incluida 1 Chapa de cierre para top mod.TPA-7)  
**cm. 60x 70,5x 90h**



⚡ 13,5 kW **3.525,00**  
400V~3N 78 / 0,54  
50/60 Hz

### COMBINAZIONI

- Combinations / • Zusammenstellungen
- Combinaisons / • Combinación múltiple



MOD. \_\_\_\_\_  
COD. \_\_\_\_\_

DESCRIZIONE/DESCRIPTION/BEZEICHNUNG/DESCRIPTION/DESCRIPCIÓN  
DIMENSIONI/DIMENSIONS/ABMESSUNGEN/DIMENSIONS/DIMENSIONES

POTENZA/POWER/LEISTUNG/PUISSANCE/POTENCIA  
VOLTAGGIO/VOLTAGE/SPANNUNG/VOLTAGE/VOLTAJE

⚡ kW kcal/h  
V~ Hz

PREZZO/PRICE €  
PREIS/PRIX/PRECIO €  
KG / M<sup>3</sup>

**CP-78ET**  
08100830

**CUOCIPASTA TRIFASE LT. 25+25 2 VASCHE CM. 30,5X33,5X30H. RUBINETTO CARICO ACQUA, SFIORATORE + SCARICO A PAVIMENTO (CESTI ESCLUSI) (INCLUSA 1 TESTATA CHIUSURA PIANO MOD.TPA-7)**

**EN** Pasta cooker threephase 25+25 lts. 2 Tanks cm. 30,5x33,5x30h. Water loading cock + overflow device and floor draining (BASKETS EXCLUDED) (included 1 Head end filler strip mod.TPA-7) • **DE** Nudelkocher dreiphasig lt. 25+25 2 Becken cm. 30,5x33,5x30h. Wasserlauf-Hahn, + Überlauf-Vorrichtung und Ablauf am Boden (KORB AUSGESCHLOSSEN) (inbegriffen 1 Abschluss-Element mod.TPA-7) • **FR** Cuiseur à pâtes triphase lt. 25+25 2 Cuves cm.30,5x33,5x30h. Robinet d'arrivée d'eau trop plein + système de vidange au sol En (PANIERS EXCLUS) (inclus 1 Élément de jonction top mod.TPA-7) • **ES** Cuece pasta trifásico. 25+25 lt. 2 Cubas cm. 30,5x33,5x30h. Grifo carga agua + vertedero + descarga a pavimento (CESTAS EXCLUIDAS) (incluida 1 Chapa de cierre para top mod.TPA-7)  
**cm. 80x 70,5x 90h**



⚡ 15,6 kW **4.174,00**  
400V~3N 82 / 0,71  
50/60 Hz

### COMBINAZIONI

- Combinations / • Zusammenstellungen
- Combinaisons / • Combinación múltiple

1/1	1/2 1/2	1/4 1/4	1/6 1/6	1/6
		1/4 1/4	1/6 1/6	1/2 1/6
			1/6 1/6	1/6

**CPA-78ET**  
08100835

**CUOCIPASTA TRIFASE LT. 25+25 2 VASCHE CM. 30,5X33,5X30H. CARICO ACQUA AUTOMATICO CON SENSORE DI LIVELLO - SFIORATORE + SCARICO A PAVIMENTO (CESTI ESCLUSI) (INCLUSA 1 TESTATA CHIUSURA PIANO MOD.TPA-7)**

**EN** Pasta cooker threephase 25+25 lts. 2 Tanks cm. 30,5x33,5x30h. Automatic Water loading with level sensor - overflow device and floor draining (BASKETS EXCLUDED) (included 1 Head end filler strip mod.TPA-7) • **DE** Nudelkocher dreiphasig lt. 25+25 2 Becken cm. 30,5x33,5x30h. Automatische Wasser Beladung mit Niveauregulierung + Überlauf-Vorrichtung und Ablauf am Boden (KORB AUSGESCHLOSSEN) (inbegriffen 1 Abschluss-Element mod.TPA-7) • **FR** Cuiseur à pâtes triphase lt. 25+25 2 Cuves cm.30,5x33,5x30h. Chargement automatique de l'eau avec sensor de niveau, trop plein Système de vidange au sol (PANIERS EXCLUS) (inclus 1 Élément de jonction top mod.TPA-7) • **ES** Cuece pasta trifásico. 25+25 lt. 2 Cubas cm. 30,5x33,5x30h. Carga automática de agua con sensor de nivel + vertedero + descarga a pavimento. (CESTAS EXCLUIDAS) (incluida 1 Chapa de cierre para top mod.TPA-7)  
**cm. 80x 70,5x 90h**



⚡ 15,6 kW **4.561,00**  
400V~3N 82 / 0,71  
50/60 Hz

### COMBINAZIONI

- Combinations / • Zusammenstellungen
- Combinaisons / • Combinación múltiple

1/1	1/2 1/2	1/4 1/4	1/6 1/6	1/6
		1/4 1/4	1/6 1/6	1/2 1/6
			1/6 1/6	1/6

# CUOCIPASTA A GAS

MOD. \_\_\_\_\_  
COD. \_\_\_\_\_

DESCRIZIONE/DESCRIPTION/BEZEICHNUNG/DESCRIPTION/DESCRIPCIÓN  
DIMENSIONI/DIMENSIONS/ABMESSUNGEN/DIMENSIONS/DIMENSIONES

POTENZA/POWER/LEISTUNG/PUISSANCE/POTENCIA  
VOLTAGGIO/VOLTAGE/SPANNUNG/VOLTAGE/VOLTAGE

9,5 kW  
8.160 kcal/h

PREZZO/PRICE €  
61 / 0,37  
KG / M<sup>3</sup>

**CP-74G**  
08270450

**CUOCIPASTA GAS LT 25 VASCA CM. 30,5X33,5X32,7H. RUBINETTO CARICO ACQUA, SFIORATORE + SCARICO A PAVIMENTO. (CESTI ESCLUSI) (INCLUSA 1 TESTATA CHIUSURA PIANO MOD.TPA-7)**  
**EN** Gas pasta cooker 25 lts. Tank cm. 30,5x33,5x32,7h. Water loading cock + overflow device and floor draining (BASKETS EXCLUDED) (included 1 Head end filler strip mod.TPA-7) • **DE** Gas-Nudelkocher lt. 25. Becken cm. 30,5x33,5x32,7h. Wasserlauf-Hahn, + Überlauf-Vorrichtung und Ablauf am Boden (KORB AUSGESCHLOSSEN) (inbegriffen 1 Abschluss-Element mod.TPA-7) • **FR** Cuiseur à pâtes gaz lt. 25. Cuve cm.30,5x33,5x32,7h. Robinet d'arrivée d'eau trop plein + système de vidange au sol (PANIERS EXCLUS) (inclus 1 Élément de jonction top mod.TPA-7) • **ES** Cuece pasta gas 25 lt. Cuba cm. 30,5x33,5x32,7h. Grifo carga agua + vertedero + descarga a pavimento (CESTAS EXCLUIDAS) (incluida 1 Chapa de cierre para top mod.TPA-7)  
**cm. 40x 70,5x 90h**



9,5 kW  
8.160 kcal/h

**2.957,00**  
61 / 0,37

0,02 KW  
230V~  
50/60 Hz

## COMBINAZIONI

- Combinations / • Zusammenstellungen
- Combinaisons / • Combinación múltiple



**CPA-74G**  
08270455

**CUOCIPASTA GAS LT 25 VASCA CM. 30,5X33,5X32,7H. CARICO ACQUA AUTOMATICO CON SENSORE DI LIVELLO - SFIORATORE + SCARICO A PAVIMENTO (CESTI ESCLUSI) (INCLUSA 1 TESTATA CHIUSURA PIANO MOD.TPA-7)**  
**EN** Gas pasta cooker 25 lts. Tank cm. 30,5x33,5x32,7h. Automatic Water loading with level sensor - overflow device and floor draining (BASKETS EXCLUDED) (included 1 Head end filler strip mod.TPA-7) • **DE** Gas-Nudelkocher lt. 25. Becken cm. 30,5x33,5x32,7h. Automatische Wasser Beladung mit Niveauregulierung + Überlauf-Vorrichtung und Ablauf am Boden (KORB AUSGESCHLOSSEN) (inbegriffen 1 Abschluss-Element mod.TPA-7) • **FR** Cuiseur à pâtes gaz lt. 25. Cuve cm.30,5x33,5x32,7h. Chargement automatique de l'eau avec sensor de niveau, trop plein Système de vidange au sol (PANIERS EXCLUS) (inclus 1 Élément de jonction top mod.TPA-7) • **ES** Cuece pasta gas 25 lt. Cuba cm. 30,5x33,5x32,7h. Carga automática de agua con sensor de nivel + vertedero + descarga a pavimento. (CESTAS EXCLUIDAS) (incluida 1 Chapa de cierre para top mod.TPA-7)  
**cm. 40x 70,5x 90h**



9,5 kW  
8.160 kcal/h

**3.178,00**  
61 / 0,37

0,035 KW  
230V~  
50/60 Hz

## COMBINAZIONI

- Combinations / • Zusammenstellungen
- Combinaisons / • Combinación múltiple



Le immagini presentate non sono vincolanti. La ditta si riserva di apportare modifiche senza preavviso. • The pictures are purely representative. The manufacturer reserves the right to modify the technical data and models without previous notice. • Les images

LO

présentées ne nous engagent pas. La Société se réserve le droit d'apporter tout modification sans préavis. • Die dargestellten Abbildungen sind nicht verbindlich. Technische Änderungen vorbehalten. • Las imágenes presentadas no son vinculantes. El Fabricante se reserva el derecho de modificar sus productos sin previo aviso.

01/20

141

MOD. \_\_\_\_\_  
COD. \_\_\_\_\_

DESCRIZIONE/DESCRIPTION/BEZEICHNUNG/DESCRIPTION/DESCRIPCIÓN  
DIMENSIONI/DIMENSIONS/ABMESSUNGEN/DIMENSIONS/DIMENSIONES

POTENZA/POWER/LEISTUNG/PUISSANCE/POTENCIA  
VOLTAGGIO/VOLTAGE/SPANNUNG/VOLTAGE/VOLTAJE

⚡ 13,95 kW  
11.997 kcal/h

PREZZO/PRICE €  
PREIS/PRIX/PRECIO €  
KG / M<sup>3</sup>

**CP-76G**  
08270650

**CUOCIPASTA GAS LT 40 VASCA CM. 51X30,7X32,7H. RUBINETTO CARICO ACQUA, SFIORATORE + SCARICO A PAVIMENTO. (CESTI ESCLUSI) (INCLUSA 1 TESTATA CHIUSURA PIANO MOD.TPA-7)**

**EN** Gas pasta cooker 40 lts. Tank cm. 51x30,7x32,7h. Water loading cock + overflow device and floor draining (BASKETS EXCLUDED) (included 1 Head end filler strip mod.TPA-7) • **DE** Gas-Nudelkocher lt. 40. Becken cm. 51x30,7x32,7h. Wasserlauf-Hahn, + Überlauf-Vorrichtung und Ablauf am Boden (KORB AUSGESCHLOSSEN) (inbegriffen 1 Abschluss-Element mod.TPA-7) • **FR** Cuiseur à pâtes gaz lt. 40. Cuve cm.51x30,7x32,7h. Robinet d'arrivée d'eau trop plein + système de vidange au sol (PANIERS EXCLUS) (inclus 1 Élément de jonction top mod.TPA-7) • **ES** Cuece pasta gas 40 lt. Cuba cm. 51x30,7x32,7h. Grifo carga agua + vertedero + descarga a pavimento (CESTAS EXCLUIDAS) (incluida 1 Chapa de cierre para top mod. TPA-7)

**cm. 60x 70,5x 90h**

**COMBINAZIONI**

- Combinations / • Zusammenstellungen
- Combinaisons / • Combinación múltiple



⚡ 13,95 kW  
11.997 kcal/h

**3.213,00**  
80 / 0,54

⚡ 0,02 KW  
230V~  
50/60 Hz

**CPA-76G**  
08270655

**CUOCIPASTA GAS LT 40 VASCA CM. 51X30,7X32,7H. CARICO ACQUA AUTOMATICO CON SENSORE DI LIVELLO - SFIORATORE + SCARICO A PAVIMENTO (CESTI ESCLUSI) (INCLUSA 1 TESTATA CHIUSURA PIANO MOD.TPA-7)**

**EN** Gas pasta cooker 40 lts. Tank cm. 51x30,7x32,7h. Automatic Water loading with level sensor - overflow device and floor draining (BASKETS EXCLUDED) (included 1 Head end filler strip mod.TPA-7) • **DE** Gas-Nudelkocher lt. 40. Becken cm. 51x30,7x32,7h. Automatische Wasser Beladung mit Niveauregulierung + Überlauf-Vorrichtung und Ablauf am Boden (KORB AUSGESCHLOSSEN) (inbegriffen 1 Abschluss-Element mod.TPA-7) • **FR** Cuiseur à pâtes gaz lt. 40. Cuve cm.51x30,7x32,7h. Chargement automatique de l'eau avec sensor de niveau, trop plein Système de vidange au sol (PANIERS EXCLUS) (inclus 1 Élément de jonction top mod.TPA-7) • **ES** Cuece pasta gas 40 lt. Cuba cm. 51x30,7x32,7h. Carga automática de agua con sensor de nivel + vertedero + descarga a pavimento. (CESTAS EXCLUIDAS) (incluida 1 Chapa de cierre para top mod. TPA-7)

**cm. 60x 70,5x 90h**

**COMBINAZIONI**

- Combinations / • Zusammenstellungen
- Combinaisons / • Combinación múltiple



⚡ 13,95 kW  
11.997 kcal/h

**3.434,00**  
80 / 0,54

⚡ 0,035 KW  
230V~  
50/60 Hz

MOD. \_\_\_\_\_  
COD. \_\_\_\_\_

DESCRIZIONE/DESCRIPTION/BEZEICHNUNG/DESCRIPTION/DESCRIPCIÓN  
DIMENSIONI/DIMENSIONS/ABMESSUNGEN/DIMENSIONS/DIMENSIONES

POTENZA/POWER/LEISTUNG/PUISSANCE/POTENCIA  
VOLTAGGIO/VOLTAGE/SPANNUNG/VOLTAGE/VOLTAJE

⚡ 19 kW  
16.320 kcal/h

PREZZO/PRICE €  
PREIS/PRIX/PRECIO €  
KG / M<sup>3</sup>

**CP-78G**  
08270850

**CUOCIPASTA GAS LT. 25+25 2 VASCHE  
CM. 30,5X33,5X32,7H. RUBINETTO  
CARICO ACQUA, SFIORATORE + SCARICO  
A PAVIMENTO (CESTI ESCLUSI) (INCLUSA 1  
TESTATA CHIUSURA PIANO MOD.TPA-7)**  
**EN** Gas pasta cooker 25+25 lts. 2 Tanks cm.  
30,5x33,5x32,7h. Water loading cock + overflow  
device and floor draining. (BASKETS EXCLUDED)  
(included 1 Head end filler strip mod.TPA-7) • **DE** Gas-  
Nudelkocher lt. 25+25 2 Becken cm. 30,5x33,5x32,7h.  
Wasserlauf-Hahn, + Überlauf-Vorrichtung und Ablauf  
am Boden (KORB AUSGESCHLOSSEN) (inbegriffen 1  
Abschluss-Element mod.TPA-7) • **FR** Cuiseur à pates  
gaz lt. 25+25 2 Cuves cm.30,5x33,5x32,7h. robinet  
d'arrivée d'eau trop plein + système de vidange au sol  
(PANIERS EXCLUS) (inclus 1 Élément de jonction top  
mod.TPA-7) • **ES** Cuece pasta gas 25+25 lt. 2 Cubas  
cm. 30,5x33,5x32,7h. Grifo carga agua + vertedero +  
descarga a pavimento (CESTAS EXCLUIDAS) (incluida 1  
Chapa de cierre para top mod.TPA-7)  
**cm. 80x 70,5x 90h**



⚡ 19 kW  
16.320 kcal/h

**4.628,00**  
103 / 0,71

⚡ 0,04 KW  
230V~  
50/60 Hz

### COMBINAZIONI

- Combinations / • Zusammenstellungen
- Combinaisons / • Combinación múltiple



**CPA-78G**  
08270855

**CUOCIPASTA GAS LT. 25+25 2 VASCHE  
CM. 30,5X33,5X32,7H. CARICO ACQUA  
AUTOMATICO CON SENSORE DI LIVELLO -  
SFIORATORE + SCARICO A PAVIMENTO (CESTI  
ESCLUSI) (INCLUSA 1 TESTATA CHIUSURA  
PIANO MOD.TPA-7)**  
**EN** Gas pasta cooker 25+25 lts. 2 Tanks cm.  
30,5x33,5x32,7h. Automatic Water loading with level  
sensor - overflow device and floor draining (BASKETS  
EXCLUDED) (included 1 Head end filler strip mod.  
TPA-7) • **DE** Gas-Nudelkocher lt. 25+25 2 Becken cm.  
30,5x33,5x32,7h. Automatische Wasser Beladung mit  
Niveauregulierung + Überlauf-Vorrichtung und Ablauf  
am Boden (KORB AUSGESCHLOSSEN) (inbegriffen  
1 Abschluss-Element mod.TPA-7) • **FR** Cuiseur à  
pates gaz lt. 25+25 2 Cuves cm.30,5x33,5x32,7h.  
Chargement automatique de l'eau avec sensor de  
niveau, trop plein Système de vidange au sol (PANIERS  
EXCLUS) (inclus 1 Élément de jonction top mod.  
TPA-7) • **ES** Cuece pasta gas 25+25 lt. 2 Cubas cm.  
30,5x33,5x32,7h. Carga automática de agua con  
sensor de nivel + vertedero + descarga a pavimento.  
(CESTAS EXCLUIDAS) (incluida 1 Chapa de cierre para  
top mod.TPA-7)  
**cm. 80x 70,5x 90h**



⚡ 19 kW  
16.320 kcal/h

**5.070,00**  
103 / 0,71

⚡ 0,07 KW  
230V~  
50/60 Hz

### COMBINAZIONI

- Combinations / • Zusammenstellungen
- Combinaisons / • Combinación múltiple





# SOLLEVATORE CESTI

MOD. \_\_\_\_\_  
COD. \_\_\_\_\_

DESCRIZIONE/DESCRIPTION/BEZEICHNUNG/DESCRIPTION/DESCRIPCIÓN  
DIMENSIONI/DIMENSIONS/ABMESSUNGEN/DIMENSIONS/DIMENSIONES

POTENZA/POWER/LEISTUNG/PUISSANCE/POTENCIA  
VOLTAGGIO/VOLTAGE/SPANNUNG/VOLTAGE/VOLTAJE

⚡ kW \_\_\_\_\_  
230V~  
50/60 Hz

PREZZO/PRICE €  
PREIS/PRIX/PRECIO €  
KG / M<sup>3</sup>

**SCCP-72EM** SOLLEVATORE CESTI DA AFFIANCARE AI  
08140210 **CUOCIPASTA CP-74/78, SOLLEVAMENTO  
AUTOMATICO TEMPORIZZATO O MANUALE, 2  
ASTE (INCLUSA 1 TESTATA CHIUSURA PIANO  
MOD.TPA-7)**

**EN** basket elevator for pasta cooker CP-74/78,  
automatic timed or manual lifting, 2 rods (included 1  
Head end filler strip mod.TPA-7) • **DE** heben Korbe für  
Nudelkocher CP-74/78, Timed oder manuelle Heben,  
2 Stangen (inbegriffen 1 Abschluss-Element mod.  
TPA-7) • **FR** soulever des paniers pour cuiseur a pates  
CP-74/78, soulèvement temporisé ou manuel, 2 tiges  
(inclus 1 Élément de jonction top mod.TPA-7) • **ES**  
levante cestas para cuece pasta CP-74/78, elevación  
temporizado o manual, 2 barras (incluida 1 Chapa de  
cierre para top mod.TPA-7)  
**cm. 20x 70,5x 90h**



⚡ 0,35 kW \_\_\_\_\_ **2.657,00**  
230V~ \_\_\_\_\_ 45 / 0,37  
50/60 Hz

**COMBINAZIONI**

- Combinations / • Zusammenstellungen
- Combinaisons / • Combinación múltiple

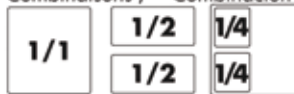

**PI50-78ET** PENTOLA INDIRETTA ELETTRICA LT. 50  
08110831 **VASCA Ø CM. 40X45H (INCLUSA 1 TESTATA  
CHIUSURA PIANO MOD.TPA-7)**

**EN** Electric indirect boiling pan 50 lts. Tank Ø cm.  
40x45h (included 1 Head end filler strip mod.TPA-7)  
• **DE** Indirekter Elektro-kochkessel lt. 50 Becken Ø cm.  
40x45h (inbegriffen 1 Abschluss-Element mod.TPA-7)  
• **FR** Marmite indirecte électrique lt. 50 Cuve Ø cm.  
40x45h (inclus 1 Élément de jonction top mod.TPA-7)  
• **ES** Marmita de calefacción indirecta 50 lt. Cuba Ø  
cm. 40x45h (incluida 1 Chapa de cierre para top mod.  
TPA-7)  
**cm. 80x 70,5x 90h**



⚡ 9 kW \_\_\_\_\_ **5.952,00**  
400V~3N \_\_\_\_\_ 120 / 0,71  
50/60 Hz

**PI50A-78ET** PENTOLA INDIRETTA ELETTRICA LT. 50 VASCA  
0811A831 **Ø CM. 40X45H - CARICO AUTOMATICO  
INTERCAPEDINE (INCLUSA 1 TESTATA  
CHIUSURA PIANO MOD.TPA-7)**

**EN** Electric indirect boiling pan 50 lts. Tank Ø cm.  
40x45h - automatic water-charge of double jacket.  
(included 1 Head end filler strip mod.TPA-7) • **DE**  
Indirekter Elektro-kochkessel lt. 50 Becken Ø cm. 40x45h  
- automatische Wasserstandskontrolle im Zwischenmantel  
(inbegriffen 1 Abschluss-Element mod.TPA-7) • **FR**  
Marmite indirecte électrique lt. 50 Cuve Ø cm. 40x45h  
- remplissage automatique dans la double paroi (inclus  
1 Élément de jonction top mod.TPA-7) • **ES** Marmita de  
calefacción indirecta 50 lt. Cuba Ø cm. 40x45h - carga  
automática de la camisa intercambiador (incluida 1  
Chapa de cierre para top mod.TPA-7)  
**cm. 80x 70,5x 90h**

⚡ 9 kW \_\_\_\_\_ **7.759,00**  
400V~3N \_\_\_\_\_ 120 / 0,71  
50/60 Hz

**PD50-78G** PENTOLA DIRETTA GAS LT. 50 VASCA Ø CM.  
08280850 **40X45H (INCLUSA 1 TESTATA CHIUSURA  
PIANO MOD.TPA-7)**

**EN** Gas direct boiling pan 50 lts - Tank Ø cm. 40x45h  
(included 1 Head end filler strip mod.TPA-7) • **DE**  
Direkter Gas-Kochkessel lt. 50 - Becken Ø cm. 40x45h  
(inbegriffen 1 Abschluss-Element mod.TPA-7) • **FR**  
Marmite directe à gaz lt. 50 - Cuve Ø cm. 40x45h  
(inclus 1 Élément de jonction top mod.TPA-7) • **ES**  
Marmita de calefacción directa 50 lt. Cuba Ø cm.  
40x45h (incluida 1 Chapa de cierre para top mod.  
TPA-7)  
**cm. 80x 70,5x 90h**



⚡ 15,5 kW \_\_\_\_\_ **4.803,00**  
13.330 kcal/h \_\_\_\_\_ 110 / 0,71

MOD. \_\_\_\_\_  
COD. \_\_\_\_\_

DESCRIZIONE/DESCRIPTION/BEZEICHNUNG/DESCRIPTION/DESCRIPCIÓN  
DIMENSIONI/DIMENSIONS/ABMESSUNGEN/DIMENSIONS/DIMENSIONES

POTENZA/POWER/LEISTUNG/PUISSANCE/POTENCIA  
VOLTAGGIO/VOLTAGE/SPANNUNG/VOLTAGE/VOLTAJE

⚡  $\frac{15,5 \text{ kW}}{13.330 \text{ kcal/h}}$   $\frac{15,5 \text{ kW}}{13.330 \text{ kcal/h}}$   
V~  
Hz

PREZZO/PRICE €  
PREIS/PRIX/PRECIO €  
KG / M<sup>3</sup>

**PI50-78G**  
08280851

**PENTOLA INDIRETTA A GAS LT. 50 VASCA Ø CM. 40X45H (INCLUSA 1 TESTATA CHIUSURA PIANO MOD.TPA-7)**

**EN** Gas indirect boiling pan 50 lts. - Tank Ø cm. 40x45h (included 1 Head end filler strip mod.TPA-7)  
• **DE** Indirekter Gas-Kochkessel lt. 50 - Becken Ø cm. 40x45h (inbegriffen 1 Abschluss-Element mod.TPA-7) • **FR** Marmite indirecte à gaz lt. 50 - Cuve Ø cm. 40x45h (inclus 1 Élément de jonction top mod.TPA-7) • **ES** Marmita de calefacción indirecta a gas lt. 50 Cuba Ø cm. 40x45h (incluida 1 Chapa de cierre para top mod.TPA-7)  
**cm. 80x 70,5x 90h**



⚡  $\frac{15,5 \text{ kW}}{13.330 \text{ kcal/h}}$  **6.229,00**  
120 / 0,71

**PI50A-78G**  
0828A851

**PENTOLA INDIRETTA A GAS LT. 50 VASCA Ø CM. 40X45H - CARICO AUTOMATICO INTERCAPEDINE (INCLUSA 1 TESTATA CHIUSURA PIANO MOD.TPA-7)**

**EN** Gas indirect boiling pan 50 lts. - Tank Ø cm. 40x45h - automatic water-charge of double jacket. (included 1 Head end filler strip mod.TPA-7) • **DE** Indirekter Gas-Kochkessel lt. 50 - Becken Ø cm. 40x45h - automatische Wasserstandskontrolle im Zwischenmantel (inbegriffen 1 Abschluss-Element mod.TPA-7) • **FR** Marmite indirecte à gaz lt. 50 - Cuve Ø cm. 40x45h - remplissage automatique dans la double paroi (inclus 1 Élément de jonction top mod.TPA-7) • **ES** Marmita de calefacción indirecta a gas lt. 50 Cuba Ø cm. 40x45h - carga automática de la camisa intercambiador (incluida 1 Chapa de cierre para top mod.TPA-7)  
**cm. 80x 70,5x 90h**

⚡  $\frac{15,5 \text{ kW}}{13.330 \text{ kcal/h}}$  **8.186,00**  
120 / 0,71

⚡  $\frac{0,1}{230V\sim}$   
50/60 Hz

**531032701 OPTIONAL: CESTO 1/1 PER PENTOLA**

**EN** Optional: Basket 1/1 for boiling pan • **DE** Zubehör: Korb 1/1 für Kochkessel • **FR** En option: Panier 1/1 pour marmite • **ES** Opcional: Cesta 1/1 por marmita  
**cm.Ø 36x 39,5h**

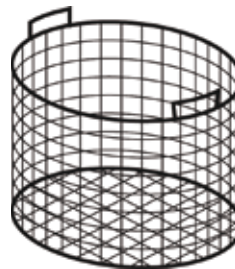

**715,00**  
5 / 0,08

**FTL-74ET**  
08060431

**FRY-TOP ELETTRICO LISCIO, SU MOBILE A GIORNO, PIASTRA CM.36X51 (INCLUSA 1 TESTATA CHIUSURA PIANO MOD.TPA-7)**

**EN** Electric Fry-top smooth griddle, on open cabinet, plate cm.36x51 (included 1 Head end filler strip mod.TPA-7) • **DE** Griddleplatte elektrische glatt, mit offenem Unterbau, platte cm.36x51 (inbegriffen 1 Abschluss-Element mod.TPA-7) • **FR** Plaque électriques lisse, sur armoire ouvert, plaque cm.36x51 (inclus 1 Élément de jonction top mod.TPA-7) • **ES** Fry-top eléctrico liso, sobre mueble abierto, plancha cm.36x51 (incluida 1 Chapa de cierre para top mod.TPA-7)  
**cm. 40x 70,5x 90h**



⚡  $\frac{5,55 \text{ kW}}{400V\sim 3N}$  **1.693,00**  
 $\frac{5,55 \text{ kW}}{230V\sim 3}$  64 / 0,37  
50/60 Hz

MOD. \_\_\_\_\_  
COD. \_\_\_\_\_

DESCRIZIONE/DESCRIPTION/BEZEICHNUNG/DESCRIPTION/DESCRIPCIÓN  
DIMENSIONI/DIMENSIONS/ABMESSUNGEN/DIMENSIONS/DIMENSIONES

POTENZA/POWER/LEISTUNG/PUISSANCE/POTENCIA  
VOLTAGGIO/VOLTAGE/SPANNUNG/VOLTAGE/VOLTAJE

⚡ kW kcal/h  
⚡ kW V~ Hz

PREZZO/PRICE €  
PREIS/PRIX/PRECIO €  
KG / M<sup>3</sup>

**FTL-74ETS**  
08060434

**FRY-TOP ELETTRICO LISCIO CROMATO SUPERCHROME (MOCA APPROVED), SU MOBILE A GIORNO, PIASTRA CM.36X51 (INCLUSA 1 TESTATA CHIUSURA PIANO MOD. TPA-7)**

**EN** Electric Fry-top smooth chromed griddle SUPERCHROME (Moca Approved), on open cabinet, plate cm.36x51 (included 1 Head end filler strip mod.TPA-7) • **DE** Griddleplatte elektrische glatt hartverchromt SUPERCHROME (Moca Approved), mit offenem Unterbau, platte cm.36x51 (inbegriffen 1 Abschluss-Element mod.TPA-7) • **FR** Plaque électriques lisse chromée SUPERCHROME (Moca Approved), sur armoire ouvert, plaque cm.36x51 (inclus 1 Élément de jonction top mod.TPA-7) • **ES** Fry-top eléctrico liso cromado SUPERCHROME (Moca Approved), sobre mueble abierto, plancha cm.36x51 (incluida 1 Chapa de cierre para top mod.TPA-7)  
**cm. 40x 70,5x 90h**



⚡ 5,55 kW 2.019,00  
400V~3N 64 / 0,37  
230V~3  
50/60 Hz

**FTR-74ET**  
08060433

**FRY-TOP ELETTRICO RIGATO, SU MOBILE A GIORNO, PIASTRA CM.36X51 (INCLUSA 1 TESTATA CHIUSURA PIANO MOD.TPA-7)**

**EN** Electric Fry-top grooved griddle, on open cabinet, plate cm.36x51 (included 1 Head end filler strip mod.TPA-7) • **DE** Griddleplatte elektrische gerillt, mit offenem Unterbau, platte cm.36x51 (inbegriffen 1 Abschluss-Element mod.TPA-7) • **FR** Plaque électriques nervurée, sur armoire ouvert, plaque cm.36x51 (inclus 1 Élément de jonction top mod.TPA-7) • **ES** Fry-top eléctrico estriado, sobre mueble abierto, plancha cm.36x51 (incluida 1 Chapa de cierre para top mod.TPA-7)  
**cm. 40x 70,5x 90h**



⚡ 5,55 kW 1.806,00  
400V~3N 64 / 0,37  
230V~3  
50/60 Hz

**FTR-74ETS**  
08060436

**FRY-TOP ELETTRICO RIGATO CROMATO SUPERCHROME (MOCA APPROVED), SU MOBILE A GIORNO, PIASTRA CM.36X51 (INCLUSA 1 TESTATA CHIUSURA PIANO MOD. TPA-7)**

**EN** Electric Fry-top grooved chromed griddle SUPERCHROME (Moca Approved), on open cabinet, plate cm.36x51 (included 1 Head end filler strip mod.TPA-7) • **DE** Griddleplatte elektrische gerillt hartverchromt SUPERCHROME (Moca Approved), mit offenem Unterbau, platte cm.36x51 (inbegriffen 1 Abschluss-Element mod.TPA-7) • **FR** Plaque électriques nervurée chromée SUPERCHROME (Moca Approved), sur armoire ouvert, plaque cm.36x51 (inclus 1 Élément de jonction top mod.TPA-7) • **ES** Fry-top eléctrico estriado cromado SUPERCHROME (Moca Approved), sobre mueble abierto, plancha cm.36x51 (incluida 1 Chapa de cierre para top mod.TPA-7)  
**cm. 40x 70,5x 90h**

⚡ 5,55 kW 2.090,00  
400V~3N 64 / 0,37  
230V~3  
50/60 Hz

**FTL-76ET**  
08060631

**FRY-TOP ELETTRICO LISCIO, SU MOBILE A GIORNO, PIASTRA CM.56X51 (INCLUSA 1 TESTATA CHIUSURA PIANO MOD.TPA-7)**

**EN** Electric Fry-top smooth griddle, on open cabinet, plate cm.56x51 (included 1 Head end filler strip mod.TPA-7) • **DE** Griddleplatte elektrische glatt, mit offenem Unterbau, platte cm.56x51 (inbegriffen 1 Abschluss-Element mod.TPA-7) • **FR** Plaque électriques lisse, sur armoire ouvert, plaque cm.56x51 (inclus 1 Élément de jonction top mod.TPA-7) • **ES** Fry-top eléctrico liso, sobre mueble abierto, plancha cm.56x51 (incluida 1 Chapa de cierre para top mod.TPA-7)  
**cm. 60x 70,5x 90h**



⚡ 7,4 kW 2.045,00  
400V~3N 78 / 0,54  
50/60 Hz

MOD. \_\_\_\_\_  
COD. \_\_\_\_\_

DESCRIZIONE/DESCRIPTION/BEZEICHNUNG/DESCRIPTION/DESCRIPCIÓN  
DIMENSIONI/DIMENSIONS/ABMESSUNGEN/DIMENSIONS/DIMENSIONES

POTENZA/POWER/LEISTUNG/PUISSANCE/POTENCIA  
VOLTAGGIO/VOLTAGE/SPANNUNG/VOLTAGE/VOLTAJE

⚡ kW kcal/h  
√ kw  
Hz

PREZZO/PRICE €  
PREIS/PRIX/PRECIO €  
KG / M<sup>3</sup>

**FTL-76ETS**  
08060634

**FRY-TOP ELETTRICO LISCIO CROMATO SUPERCHROME (MOCA APPROVED), SU MOBILE A GIORNO, PIASTRA CM.56X51 (INCLUSA 1 TESTATA CHIUSURA PIANO MOD. TPA-7)**

**EN** Electric Fry-top smooth chromed griddle SUPERCHROME (Moca Approved), on open cabinet, plate cm.56x51 (included 1 Head end filler strip mod.TPA-7) • **DE** Griddleplatte elektrische glatt hartverchromt SUPERCHROME (Moca Approved), mit offenem Unterbau, platte cm.56x51 (inbegriffen 1 Abschluss-Element mod.TPA-7) • **FR** Plaque électriques lisse chromée SUPERCHROME (Moca Approved), sur armoire ouvert, plaque cm.56x51 (inclus 1 Élément de jonction top mod.TPA-7) • **ES** Fry-top eléctrico liso cromado SUPERCHROME (Moca Approved), sobre mueble abierto, plancha cm.56x51 (incluida 1 Chapa de cierre para top mod.TPA-7)  
**cm. 60x 70,5x 90h**



⚡ 7,4 kW **2.383,00**  
400V~3N 78 / 0,54  
50/60 Hz

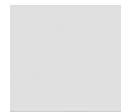

**FTLR-76ET**  
08060632

**FRY-TOP ELETTRICO 1/2 RIGATO + 1/2 LISCIO, SU MOBILE A GIORNO, PIASTRA CM.56X51 (INCLUSA 1 TESTATA CHIUSURA PIANO MOD. TPA-7)**

**EN** Electric Fry-top 1/2 grooved + 1/2 smooth, on open cabinet, plate cm.56x51 (included 1 Head end filler strip mod.TPA-7) • **DE** Griddleplatte elektrische 1/2 gerillt + 1/2 glatt, mit offenem Unterbau, platte cm.56x51 (inbegriffen 1 Abschluss-Element mod.TPA-7) • **FR** Plaque électriques 1/2 nervurée + 1/2 lisse, sur armoire ouvert, plaque cm.56x51 (inclus 1 Élément de jonction top mod.TPA-7) • **ES** Fry-top eléctrico 1/2 estriado + 1/2 liso, sobre mueble abierto, plancha cm.56x51 (incluida 1 Chapa de cierre para top mod.TPA-7)  
**cm. 60x 70,5x 90h**



⚡ 7,4 kW **2.108,00**  
400V~3N 78 / 0,54  
50/60 Hz



**FTLR-76ETS**  
08060635

**FRY-TOP ELETTRICO 1/2 RIGATO + 1/2 LISCIO CROMATO SUPERCHROME (MOCA APPROVED), SU MOBILE A GIORNO, PIASTRA CM.56X51 (INCLUSA 1 TESTATA CHIUSURA PIANO MOD.TPA-7)**

**EN** Electric Fry-top 1/2 grooved + 1/2 smooth chromed griddle SUPERCHROME (Moca Approved), on open cabinet, plate cm.56x51 (included 1 Head end filler strip mod.TPA-7) • **DE** Griddleplatte elektrische 1/2 gerillt + 1/2 glatt hartverchromt SUPERCHROME (Moca Approved), mit offenem Unterbau, platte cm.56x51 (inbegriffen 1 Abschluss-Element mod.TPA-7) • **FR** Plaque électriques 1/2 nervurée + 1/2 lisse chromée SUPERCHROME (Moca Approved), sur armoire ouvert, plaque cm.56x51 (inclus 1 Élément de jonction top mod.TPA-7) • **ES** Fry-top eléctrico 1/2 estriado + 1/2 liso cromado SUPERCHROME (Moca Approved), sobre mueble abierto, plancha cm.56x51 (incluida 1 Chapa de cierre para top mod.TPA-7)  
**cm. 60x 70,5x 90h**

⚡ 7,4 kW **2.488,00**  
400V~3N 78 / 0,54  
50/60 Hz



**FTR-76ET**  
08060633

**FRY-TOP ELETTRICO RIGATO, SU MOBILE A GIORNO, PIASTRA CM.56X51 (INCLUSA 1 TESTATA CHIUSURA PIANO MOD.TPA-7)**

**EN** Electric Fry-top grooved griddle, on open cabinet, plate cm.56x51 (included 1 Head end filler strip mod.TPA-7) • **DE** Griddleplatte elektrische gerillt, mit offenem Unterbau, platte cm.56x51 (inbegriffen 1 Abschluss-Element mod.TPA-7) • **FR** Plaque électriques nervurée, sur armoire ouvert, plaque cm.56x51 (inclus 1 Élément de jonction top mod.TPA-7) • **ES** Fry-top eléctrico estriado, sobre mueble abierto, plancha cm.56x51 (incluida 1 Chapa de cierre para top mod.TPA-7)  
**cm. 60x 70,5x 90h**



⚡ 7,4 kW **2.176,00**  
400V~3N 78 / 0,54  
50/60 Hz



70

MOD. \_\_\_\_\_  
COD. \_\_\_\_\_

DESCRIZIONE/DESCRIPTION/BEZEICHNUNG/DESCRIPTION/DESCRIPCIÓN  
DIMENSIONI/DIMENSIONS/ABMESSUNGEN/DIMENSIONS/DIMENSIONES

POTENZA/POWER/LEISTUNG/PUISSANCE/POTENCIA  
VOLTAGGIO/VOLTAGE/SPANNUNG/VOLTAGE/VOLTAJE

⚡ kW kcal/h  
√ V~  
Hz

PREZZO/PRICE €  
PREIS/PRIX/PRECIO €  
KG / M<sup>3</sup>

**FTR-76ETS**  
08060636

**FRY-TOP ELETTRICO RIGATO CROMATO SUPERCHROME (MOCA APPROVED), SU MOBILE A GIORNO, PIASTRA CM.56X51 (INCLUSA 1 TESTATA CHIUSURA PIANO MOD. TPA-7)**

**EN** Electric Fry-top grooved chromed griddle SUPERCHROME (Moca Approved), on open cabinet, plate cm.56x51 (included 1 Head end filler strip mod.TPA-7) • **DE** Griddleplatte elektrische gerillt hartverchromt SUPERCHROME (Moca Approved), mit offenem Unterbau, platte cm.56x51 (inbegriffen 1 Abschluss-Element mod.TPA-7) • **FR** Plaque électriques nervurée chromée SUPERCHROME (Moca Approved), sur armoire ouvert, plaque cm.56x51 (inclus 1 Élément de jonction top mod.TPA-7) • **ES** Fry-top eléctrico estriado cromado SUPERCHROME (Moca Approved), sobre mueble abierto, plancha cm.56x51 (incluida 1 Chapa de cierre para top mod.TPA-7)  
**cm. 60x 70,5x 90h**



⚡ 7,4 kW **2.595,00**  
400V~3N 78 / 0,54  
50/60 Hz



**FTL-78ET**  
08060831

**FRY-TOP ELETTRICO LISCIO, SU MOBILE A GIORNO, PIASTRA CM.76X51 - 2 ZONE DI COTTURA (INCLUSA 1 TESTATA CHIUSURA PIANO MOD.TPA-7)**

**EN** Electric Fry-top smooth griddle, on open cabinet, plate cm.76x51 - 2 cooking areas (included 1 Head end filler strip mod.TPA-7) • **DE** Griddleplatte elektrische glatt, mit offenem Unterbau, platte cm.76x51 - 2 Heizzonen (inbegriffen 1 Abschluss-Element mod.TPA-7) • **FR** Plaque électriques lisse, sur armoire ouvert, plaque cm.76x51 - 2 zones de cuisson (inclus 1 Élément de jonction top mod.TPA-7) • **ES** Fry-top eléctrico liso, sobre mueble abierto, plancha cm.76x51 - 2 zonas de cocción (incluida 1 Chapa de cierre para top mod.TPA-7)  
**cm. 80x 70,5x 90h**



⚡ 11,1 kW **2.528,00**  
400V~3N 110 / 0,71  
230V~3  
50/60 Hz

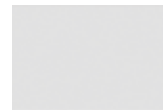

**FTL-78ETS**  
08060834

**FRY-TOP ELETTRICO LISCIO CROMATO SUPERCHROME (MOCA APPROVED), SU MOBILE A GIORNO, PIASTRA CM.76X51 - 2 ZONE DI COTTURA (INCLUSA 1 TESTATA CHIUSURA PIANO MOD.TPA-7)**

**EN** Electric Fry-top smooth chromed griddle SUPERCHROME (Moca Approved), on open cabinet, plate cm.76x51 - 2 cooking areas (included 1 Head end filler strip mod.TPA-7) • **DE** Griddleplatte elektrische glatt hartverchromt SUPERCHROME (Moca Approved), mit offenem Unterbau, platte cm.76x51 - 2 Heizzonen (inbegriffen 1 Abschluss-Element mod.TPA-7) • **FR** Plaque électriques lisse chromée SUPERCHROME (Moca Approved), sur armoire ouvert, plaque cm.76x51 - 2 zones de cuisson (inclus 1 Élément de jonction top mod.TPA-7) • **ES** Fry-top eléctrico liso cromado SUPERCHROME (Moca Approved), sobre mueble abierto, plancha cm.76x51 - 2 zonas de cocción (incluida 1 Chapa de cierre para top mod.TPA-7)  
**cm. 80x 70,5x 90h**

⚡ 11,1 kW **3.007,00**  
400V~3N 110 / 0,71  
230V~3  
50/60 Hz

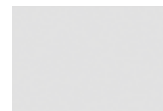

**FTLR-78ET**  
08060832

**FRY-TOP ELETTRICO 1/2 RIGATO + 1/2 LISCIO, SU MOBILE A GIORNO, PIASTRA CM.76X51 - 2 ZONE DI COTTURA (INCLUSA 1 TESTATA CHIUSURA PIANO MOD.TPA-7)**

**EN** Electric Fry-top 1/2 grooved + 1/2 smooth, on open cabinet, plate cm.76x51 - 2 cooking areas (included 1 Head end filler strip mod.TPA-7) • **DE** Griddleplatte elektrische 1/2 gerillt + 1/2 glatt, mit offenem Unterbau, platte cm.76x51 - 2 Heizzonen (inbegriffen 1 Abschluss-Element mod.TPA-7) • **FR** Plaque électriques 1/2 nervurée + 1/2 lisse, sur armoire ouvert, plaque cm.76x51 - 2 zones de cuisson (inclus 1 Élément de jonction top mod.TPA-7) • **ES** Fry-top eléctrico 1/2 estriado + 1/2 liso, sobre mueble abierto, plancha cm.76x51 - 2 zonas de cocción (incluida 1 Chapa de cierre para top mod.TPA-7)  
**cm. 80x 70,5x 90h**



⚡ 11,1 kW **2.676,00**  
400V~3N 110 / 0,71  
230V~3  
50/60 Hz





MOD. \_\_\_\_\_  
COD. \_\_\_\_\_

DESCRIZIONE/DESCRIPTION/BEZEICHNUNG/DESCRIPTION/DESCRIPCIÓN  
DIMENSIONI/DIMENSIONS/ABMESSUNGEN/DIMENSIONS/DIMENSIONES

POTENZA/POWER/LEISTUNG/PUISSANCE/POTENCIA  
VOLTAGGIO/VOLTAGE/SPANNUNG/VOLTAGE/VOLTAJE

⚡ kW kcal/h  
⚡ kW V~ Hz

PREZZO/PRICE €  
PREIS/PRIX/PRECIO €  
KG / M<sup>3</sup>

**FTLR-78ETS**  
08060835

**FRY-TOP ELETTRICO 1/2 RIGATO + 1/2 LISCIO CROMATO SUPERCHROME (MOCA APPROVED), SU MOBILE A GIORNO, PIASTRA CM.76X51 - 2 ZONE DI COTTURA (INCLUSA 1 TESTATA CHIUSURA PIANO MOD.TPA-7)**

**EN** Electric Fry-top 1/2 grooved + 1/2 smooth chromed griddle SUPERCHROME (Moca Approved), on open cabinet, plate cm.76x51 - 2 cooking areas (included 1 Head end filler strip mod.TPA-7) • **DE** Griddleplatte elektrische 1/2 gerillt + 1/2 glatt hartverchromt SUPERCHROME (Moca Approved), mit offenem Unterbau, platte cm.76x51 - 2 Heizzonen (inbegriffen 1 Abschluss-Element mod.TPA-7) • **FR** Plaque électriques 1/2 nervurée + 1/2 lisse chromée SUPERCHROME (Moca Approved), sur armoire ouvert, plaque cm.76x51 - 2 zones de cuisson (inclus 1 Élément de jonction top mod.TPA-7) • **ES** Fry-top eléctrico 1/2 estriado + 1/2 liso cromado SUPERCHROME (Moca Approved), sobre mueble abierto, plancha cm.76x51 - 2 zonas de cocción (incluida 1 Chapa de cierre para top mod.TPA-7)  
**cm. 80x 70,5x 90h**



⚡ 11,1 kW **3.130,00**  
400V~3N 110 / 0,71  
230V~3  
50/60 Hz



**FTR-78ET**  
08060833

**FRY-TOP ELETTRICO RIGATO, SU MOBILE A GIORNO, PIASTRA CM.76X51 - 2 ZONE DI COTTURA (INCLUSA 1 TESTATA CHIUSURA PIANO MOD.TPA-7)**

**EN** Electric Fry-top grooved griddle, on open cabinet, plate cm.76x51 - 2 cooking areas (included 1 Head end filler strip mod.TPA-7) • **DE** Griddleplatte elektrische gerillt, mit offenem Unterbau, platte cm.76x51 - 2 Heizzonen (inbegriffen 1 Abschluss-Element mod.TPA-7) • **FR** Plaque électriques nervurée, sur armoire ouvert, plaque cm.76x51 - 2 zones de cuisson (inclus 1 Élément de jonction top mod.TPA-7) • **ES** Fry-top eléctrico estriado, sobre mueble abierto, plancha cm.76x51 - 2 zonas de cocción (incluida 1 Chapa de cierre para top mod.TPA-7)  
**cm. 80x 70,5x 90h**



⚡ 11,1 kW **2.739,00**  
400V~3N 110 / 0,71  
230V~3  
50/60 Hz



**FTR-78ETS**  
08060836

**FRY-TOP ELETTRICO RIGATO CROMATO SUPERCHROME (MOCA APPROVED), SU MOBILE A GIORNO, PIASTRA CM.76X51 - 2 ZONE DI COTTURA (INCLUSA 1 TESTATA CHIUSURA PIANO MOD.TPA-7)**

**EN** Electric Fry-top grooved chromed griddle SUPERCHROME (Moca Approved), on open cabinet, plate cm.76x51 - 2 cooking areas (included 1 Head end filler strip mod.TPA-7) • **DE** Griddleplatte elektrische gerillt hartverchromt SUPERCHROME (Moca Approved), mit offenem Unterbau, platte cm.76x51 - 2 Heizzonen (inbegriffen 1 Abschluss-Element mod.TPA-7) • **FR** Plaque électriques nervurée chromée SUPERCHROME (Moca Approved), sur armoire ouvert, plaque cm.76x51 - 2 zones de cuisson (inclus 1 Élément de jonction top mod.TPA-7) • **ES** Fry-top eléctrico estriado cromado SUPERCHROME (Moca Approved), sobre mueble abierto, plancha cm.76x51 - 2 zonas de cocción (incluida 1 Chapa de cierre para top mod.TPA-7)  
**cm. 80x 70,5x 90h**

⚡ 11,1 kW **3.264,00**  
400V~3N 110 / 0,71  
230V~3  
50/60 Hz



# FRY-TOP ELETTRICI

MOD. \_\_\_\_\_  
COD. \_\_\_\_\_

DESCRIZIONE/DESCRIPTION/BEZEICHNUNG/DESCRIPTION/DESCRIPCIÓN  
DIMENSIONI/DIMENSIONS/ABMESSUNGEN/DIMENSIONS/DIMENSIONES

POTENZA/POWER/LEISTUNG/PUISSANCE/POTENCIA  
VOLTAGGIO/VOLTAGE/SPANNUNG/VOLTAGE/VOLTAJE

⚡ kW \_\_\_\_\_  
kcal/h \_\_\_\_\_  
V~ \_\_\_\_\_  
Hz \_\_\_\_\_

PREZZO/PRICE € \_\_\_\_\_  
PREIS/PRIX/PRECIO \_\_\_\_\_  
KG / M<sup>3</sup> \_\_\_\_\_

**FTL-712ET**  
08061231

**FRY-TOP ELETTRICO LISCIO, SU MOBILE A GIORNO, PIASTRA CM.116X51 - 2 ZONE DI COTTURA (INCLUSA 1 TESTATA CHIUSURA PIANO MOD.TPA-7)**

**EN** Electric Fry-top smooth griddle, on open cabinet, plate cm.116x51 - 2 cooking areas (included 1 Head end filler strip mod.TPA-7) • **DE** Griddleplatte elektrische glatt, mit offenem Unterbau, platte cm.116x51 - 2 Heizzonen (inbegriffen 1 Abschluss-Element mod.TPA-7) • **FR** Plaque électriques lisse, sur armoire ouvert, plaque cm.116x51 - 2 zones de cuisson (inclus 1 Élément de jonction top mod.TPA-7) • **ES** Fry-top eléctrico liso, sobre mueble abierto, plancha cm.116x51 - 2 zonas de cocción (incluida 1 Chapa de cierre para top mod. TPA-7)

**cm. 120x 70,5x 90h**



⚡ 14,8 kW \_\_\_\_\_ **3.213,00**  
400V~3N \_\_\_\_\_ 150 / 1,05  
50/60 Hz \_\_\_\_\_

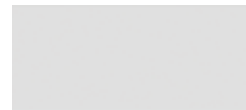

**FTL-712ETS**  
08061234

**FRY-TOP ELETTRICO LISCIO CROMATO SUPERCHROME (MOCA APPROVED), SU MOBILE A GIORNO, PIASTRA CM.116X51 - 2 ZONE DI COTTURA (INCLUSA 1 TESTATA CHIUSURA PIANO MOD.TPA-7)**

**EN** Electric Fry-top smooth chromed griddle SUPERCHROME (Moca Approved), on open cabinet, plate cm.116x51 - 2 cooking areas (included 1 Head end filler strip mod.TPA-7) • **DE** Griddleplatte elektrische glatt hartverchromt SUPERCHROME (Moca Approved), mit offenem Unterbau, platte cm.116x51 - 2 Heizzonen (inbegriffen 1 Abschluss-Element mod.TPA-7) • **FR** Plaque électriques lisse chromée SUPERCHROME (Moca Approved), sur armoire ouvert, plaque cm.116x51 - 2 zones de cuisson (inclus 1 Élément de jonction top mod.TPA-7) • **ES** Fry-top eléctrico liso cromado SUPERCHROME (Moca Approved), sobre mueble abierto, plancha cm.116x51 - 2 zonas de cocción (incluida 1 Chapa de cierre para top mod.TPA-7)

**cm. 120x 70,5x 90h**

⚡ 14,8 kW \_\_\_\_\_ **3.950,00**  
400V~3N \_\_\_\_\_ 150 / 1,05  
50/60 Hz \_\_\_\_\_

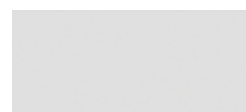

**FTLR-712ET**  
08061232

**FRY-TOP ELETTRICO 1/2 RIGATO + 1/2 LISCIO, SU MOBILE A GIORNO, PIASTRA CM.116X51 - 2 ZONE DI COTTURA (INCLUSA 1 TESTATA CHIUSURA PIANO MOD.TPA-7)**

**EN** Electric Fry-top 1/2 grooved + 1/2 smooth, on open cabinet, plate cm.116x51 - 2 cooking areas (included 1 Head end filler strip mod.TPA-7) • **DE** Griddleplatte elektrische 1/2 gerillt + 1/2 glatt, mit offenem Unterbau, platte cm.116x51 - 2 Heizzonen (inbegriffen 1 Abschluss-Element mod.TPA-7) • **FR** Plaque électriques 1/2 nervurée + 1/2 lisse, sur armoire ouvert, plaque cm.116x51 - 2 zones de cuisson (inclus 1 Élément de jonction top mod.TPA-7) • **ES** Fry-top eléctrico 1/2 estriado + 1/2 liso, sobre mueble abierto, plancha cm.116x51 - 2 zonas de cocción (incluida 1 Chapa de cierre para top mod.TPA-7)

**cm. 120x 70,5x 90h**



⚡ 14,8 kW \_\_\_\_\_ **3.362,00**  
400V~3N \_\_\_\_\_ 150 / 1,05  
50/60 Hz \_\_\_\_\_



MOD. \_\_\_\_\_  
COD. \_\_\_\_\_

DESCRIZIONE/DESCRIPTION/BEZEICHNUNG/DESCRIPTION/DESCRIPCIÓN  
DIMENSIONI/DIMENSIONS/ABMESSUNGEN/DIMENSIONS/DIMENSIONES

POTENZA/POWER/LEISTUNG/PUISSANCE/POTENCIA  
VOLTAGGIO/VOLTAGE/SPANNUNG/VOLTAGE/VOLTAJE

⚡ kW kcal/h  
V~ Hz

PREZZO/PRICE €  
PREIS/PRIX/PRECIO €  
KG / M<sup>3</sup>

**FTLR-712ETS FRY-TOP ELETTRICO 1/2 RIGATO + 1/2 LISCIO CROMATO SUPERCHROME (MOCA APPROVED), SU MOBILE A GIORNO, PIASTRA CM.116X51 - 2 ZONE DI COTTURA (INCLUSA 1 TESTATA CHIUSURA PIANO MOD.TPA-7)**  
08061235

**EN** Electric Fry-top 1/2 grooved + 1/2 smooth chromed griddle SUPERCHROME (Moca Approved), on open cabinet, plate cm.116x51 - 2 cooking areas (included 1 Head end filler strip mod.TPA-7) • **DE** Griddleplatte elektrische 1/2 gerillt + 1/2 glatt hartverchromt SUPERCHROME (Moca Approved), mit offenem Unterbau, platte cm.116x51 - 2 Heizzonen (inbegriffen 1 Abschluss-Element mod.TPA-7) • **FR** Plaque électriques 1/2 nervurée + 1/2 lisse chromée SUPERCHROME (Moca Approved), sur armoire ouvert, plaque cm.116x51 - 2 zones de cuisson (inclus 1 Élément de jonction top mod.TPA-7) • **ES** Fry-top eléctrico 1/2 estriado + 1/2 liso cromado SUPERCHROME (Moca Approved), sobre mueble abierto, plancha cm.116x51 - 2 zonas de cocción (incluida 1 Chapa de cierre para top mod.TPA-7)  
**cm. 120x 70,5x 90h**

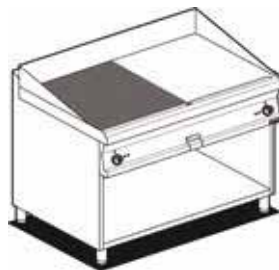

⚡ 14,8 kW **4.176,00**  
400V~3N 150 / 1,05  
50/60 Hz



**FTR-712ET FRY-TOP ELETTRICO RIGATO, SU MOBILE A GIORNO, PIASTRA CM.116X51 - 2 ZONE DI COTTURA (INCLUSA 1 TESTATA CHIUSURA PIANO MOD.TPA-7)**  
08061233

**EN** Electric Fry-top grooved griddle, on open cabinet, plate cm.116x51 - 2 cooking areas (included 1 Head end filler strip mod.TPA-7) • **DE** Griddleplatte elektrische gerillt, mit offenem Unterbau, platte cm.116x51 - 2 Heizzonen (inbegriffen 1 Abschluss-Element mod.TPA-7) • **FR** Plaque électriques nervurée, sur armoire ouvert, plaque cm.116x51 - 2 zones de cuisson (inclus 1 Élément de jonction top mod.TPA-7) • **ES** Fry-top eléctrico estriado, sobre mueble abierto, plancha cm.116x51 - 2 zonas de cocción (incluida 1 Chapa de cierre para top mod.TPA-7)  
**cm. 120x 70,5x 90h**

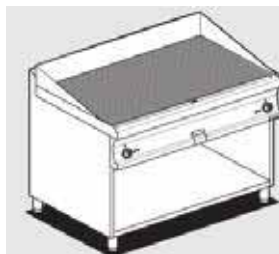

⚡ 14,8 kW **3.519,00**  
400V~3N 150 / 1,05  
50/60 Hz



**FTR-712ETS FRY-TOP ELETTRICO RIGATO CROMATO SUPERCHROME (MOCA APPROVED), SU MOBILE A GIORNO, PIASTRA CM.116X51 - 2 ZONE DI COTTURA (INCLUSA 1 TESTATA CHIUSURA PIANO MOD.TPA-7)**  
08061236

**EN** Electric Fry-top grooved chromed griddle SUPERCHROME (Moca Approved), on open cabinet, plate cm.116x51 - 2 cooking areas (included 1 Head end filler strip mod.TPA-7) • **DE** Griddleplatte elektrische gerillt hartverchromt SUPERCHROME (Moca Approved), mit offenem Unterbau, platte cm.116x51 - 2 Heizzonen (inbegriffen 1 Abschluss-Element mod.TPA-7) • **FR** Plaque électriques nervurée chromée SUPERCHROME (Moca Approved), sur armoire ouvert, plaque cm.116x51 - 2 zones de cuisson (inclus 1 Élément de jonction top mod.TPA-7) • **ES** Fry-top eléctrico estriado cromado SUPERCHROME (Moca Approved), sobre mueble abierto, plancha cm.116x51 - 2 zonas de cocción (incluida 1 Chapa de cierre para top mod.TPA-7)  
**cm. 120x 70,5x 90h**

⚡ 14,8 kW **4.467,00**  
400V~3N 150 / 1,05  
50/60 Hz



# FRY-TOP ELETTRICI

MOD. \_\_\_\_\_  
COD. \_\_\_\_\_

DESCRIZIONE/DESCRIPTION/BEZEICHNUNG/DESCRIPTION/DESCRIPCIÓN  
DIMENSIONI/DIMENSIONS/ABMESSUNGEN/DIMENSIONS/DIMENSIONES

POTENZA/POWER/LEISTUNG/PUISSANCE/POTENCIA  
VOLTAGGIO/VOLTAGE/SPANNUNG/VOLTAGE/VOLTAJE

⚡ kW kcal/h  
400V~3N  
50/60 Hz

PREZZO/PRICE €  
PREIS/PRIX/PRECIO €  
KG / M<sup>3</sup>

**FTL-712ET3**  
0806123B

**FRY-TOP ELETTRICO LISCIO, SU MOBILE A GIORNO, PIASTRA CM.116X51 - 3 ZONE DI COTTURA (INCLUSA 1 TESTATA CHIUSURA PIANO MOD.TPA-7)**

**EN** Electric Fry-top smooth griddle, on open cabinet, plate cm.116x51 - 3 cooking areas (included 1 Head end filler strip mod.TPA-7) • **DE** Griddleplatte elektrische glatt, mit offenem Unterbau, platte cm.116x51 - 3 Heizzonen (inbegriffen 1 Abschluss-Element mod.TPA-7) • **FR** Plaque électriques lisse, sur armoire ouvert, plaque cm.116x51 - 3 zones de cuisson (inclus 1 Élément de jonction top mod.TPA-7) • **ES** Fry-top eléctrico liso, sobre mueble abierto, plancha cm.116x51 - 3 zonas de cocción (incluida 1 Chapa de cierre para top mod. TPA-7)

**cm. 120x 70,5x 90h**



⚡ 16,65 kW **3.519,00**  
400V~3N 150 / 1,05  
50/60 Hz

**FTL-712ETS3**  
0806123E

**FRY-TOP ELETTRICO LISCIO CROMATO SUPERCHROME (MOCA APPROVED), SU MOBILE A GIORNO, PIASTRA CM.116X51 - 3 ZONE DI COTTURA (INCLUSA 1 TESTATA CHIUSURA PIANO MOD.TPA-7)**

**EN** Electric Fry-top smooth chromed griddle SUPERCHROME (Moca Approved), on open cabinet, plate cm.116x51 - 3 cooking areas (included 1 Head end filler strip mod.TPA-7) • **DE** Griddleplatte elektrische glatt hartverchromt SUPERCHROME (Moca Approved), mit offenem Unterbau, platte cm.116x51 - 3 Heizzonen (inbegriffen 1 Abschluss-Element mod.TPA-7) • **FR** Plaque électriques lisse chromée SUPERCHROME (Moca Approved), sur armoire ouvert, plaque cm.116x51 - 3 zones de cuisson (inclus 1 Élément de jonction top mod.TPA-7) • **ES** Fry-top eléctrico liso cromado SUPERCHROME (Moca Approved), sobre mueble abierto, plancha cm.116x51 - 3 zonas de cocción (incluida 1 Chapa de cierre para top mod.TPA-7)

**cm. 120x 70,5x 90h**

⚡ 16,65 kW **4.221,00**  
400V~3N 150 / 1,05  
50/60 Hz

**FTLR-712ET3**  
0806123C

**FRY-TOP ELETTRICO 1/3 RIGATO + 2/3 LISCIO, SU MOBILE A GIORNO, PIASTRA CM.116X51 - 3 ZONE DI COTTURA (INCLUSA 1 TESTATA CHIUSURA PIANO MOD.TPA-7)**

**EN** Electric Fry-top 1/3 grooved + 2/3 smooth, on open cabinet, plate cm.116x51 - 3 cooking areas (included 1 Head end filler strip mod.TPA-7) • **DE** Griddleplatte elektrische 1/3 gerillt + 2/3 glatt, mit offenem Unterbau, platte cm.116x51 - 3 Heizzonen (inbegriffen 1 Abschluss-Element mod.TPA-7) • **FR** Plaque électriques 1/3 nervurée + 2/3 lisse, sur armoire ouvert, plaque cm.116x51 - 3 zones de cuisson (inclus 1 Élément de jonction top mod.TPA-7) • **ES** Fry-top eléctrico 1/3 estriado + 2/3 liso, sobre mueble abierto, plancha cm.116x51 - 3 zonas de cocción (incluida 1 Chapa de cierre para top mod.TPA-7)

**cm. 120x 70,5x 90h**



⚡ 16,65 KW **3.613,00**  
400V~3N 150 / 1,05  
50/60 Hz

# FRY-TOP ELETTRICI

MOD. \_\_\_\_\_  
COD. \_\_\_\_\_

DESCRIZIONE/DESCRIPTION/BEZEICHNUNG/DESCRIPTION/DESCRIPCIÓN  
DIMENSIONI/DIMENSIONS/ABMESSUNGEN/DIMENSIONS/DIMENSIONES

POTENZA/POWER/LEISTUNG/PUISSANCE/POTENCIA  
VOLTAGGIO/VOLTAGE/SPANNUNG/VOLTAGE/VOLTAJE

$\frac{kW}{kcal/h}$   $\frac{V}{Hz}$

PREZZO/PRICE €  
PREIS/PRIX/PRECIO €  
KG / M<sup>3</sup>

**FTLR-712ETS3 FRY-TOP ELETTRICO 1/3 RIGATO + 2/3 LISCIO CROMATO SUPERCHROME (MOCA APPROVED), SU MOBILE A GIORNO, PIASTRA CM.116X51 - 3 ZONE DI COTTURA (INCLUSA 1 TESTATA CHIUSURA PIANO MOD.TPA-7)**  
0806123F

**EN** Electric Fry-top 1/3 grooved + 2/3 smooth chromed griddle SUPERCHROME (Moca Approved), on open cabinet, plate cm.116x51 - 3 cooking areas (included 1 Head end filler strip mod.TPA-7) • **DE** Griddleplatte elektrische 1/3 gerillt + 2/3 glatt hartverchromt SUPERCHROME (Moca Approved), mit offenem Unterbau, platte cm.116x51 - 3 Heizzonen (inbegriffen 1 Abschluss-Element mod.TPA-7) • **FR** Plaque électriques 1/3 nervurée + 2/3 lisse chromée SUPERCHROME (Moca Approved), sur armoire ouvert, plaque cm.116x51 - 3 zones de cuisson (inclus 1 Élément de jonction top mod.TPA-7) • **ES** Fry-top eléctrico 1/3 estriado + 2/3 liso cromado SUPERCHROME (Moca Approved), sobre mueble abierto, plancha cm.116x51 - 3 zonas de cocción (incluida 1 Chapa de cierre para top mod.TPA-7)  
**cm. 120x 70,5x 90h**



$\frac{16,65 kW}{400V-3N}$  **4.321,00**  
 $\frac{72.000 kcal/h}{50/60 Hz}$  150 / 1,05

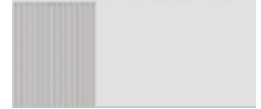

**FTL-74G FRY-TOP GAS LISCIO, SU MOBILE A GIORNO, PIASTRA CM.36X51 (INCLUSA 1 TESTATA CHIUSURA PIANO MOD.TPA-7)**  
08230451

**EN** Gas Fry-top smooth griddle, on open cabinet, plate cm.36x51 (included 1 Head end filler strip mod.TPA-7) • **DE** Gas-griddleplatte glatt, mit offenem Unterbau, platte cm.36x51 (inbegriffen 1 Abschluss-Element mod.TPA-7) • **FR** Plaque gaz lisse, sur armoire ouvert, plaque cm.36x51 (inclus 1 Élément de jonction top mod.TPA-7) • **ES** Fry-top gas liso, sobre mueble abierto, plancha cm.36x51 (incluida 1 Chapa de cierre para top mod.TPA-7)  
**cm. 40x 70,5x 90h**



$\frac{7 kW}{6.020 kcal/h}$  **1.790,00**  
69 / 0,37



**FTL-74GS FRY-TOP GAS LISCIO CROMATO SUPERCHROME (MOCA APPROVED), SU MOBILE A GIORNO, PIASTRA CM.36X51 (INCLUSA 1 TESTATA CHIUSURA PIANO MOD.TPA-7)**  
08230454

**EN** Gas Fry-top smooth chromed griddle SUPERCHROME (Moca Approved), on open cabinet, plate cm.36x51 (included 1 Head end filler strip mod.TPA-7) • **DE** Gas-griddleplatte glatt hartverchromt SUPERCHROME (Moca Approved), mit offenem Unterbau, platte cm.36x51 (inbegriffen 1 Abschluss-Element mod.TPA-7) • **FR** Plaque gaz lisse chromée SUPERCHROME (Moca Approved), sur armoire ouvert, plaque cm.36x51 (inclus 1 Élément de jonction top mod.TPA-7) • **ES** Fry-top gas liso cromado SUPERCHROME (Moca Approved), sobre mueble abierto, plancha cm.36x51 (incluida 1 Chapa de cierre para top mod.TPA-7)  
**cm. 40x 70,5x 90h**

$\frac{7 kW}{6.020 kcal/h}$  **2.120,00**  
69 / 0,37



**FTLR-74G FRY-TOP GAS RIGATO, SU MOBILE A GIORNO, PIASTRA CM.36X51 (INCLUSA 1 TESTATA CHIUSURA PIANO MOD.TPA-7)**  
08230453

**EN** Gas Fry-top grooved griddle, on open cabinet, plate cm.36x51 (included 1 Head end filler strip mod.TPA-7) • **DE** Gas-griddleplatte gerillt, mit offenem Unterbau, platte cm.36x51 (inbegriffen 1 Abschluss-Element mod.TPA-7) • **FR** Plaque gaz nervurée, sur armoire ouvert, plaque cm.36x51 (inclus 1 Élément de jonction top mod.TPA-7) • **ES** Fry-top gas estriado, sobre mueble abierto, plancha cm.36x51 (incluida 1 Chapa de cierre para top mod.TPA-7)  
**cm. 40x 70,5x 90h**

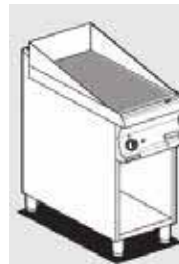

$\frac{7 kW}{6.020 kcal/h}$  **1.919,00**  
69 / 0,37



Le immagini presentate non sono vincolanti. La ditta si riserva di apportare modifiche senza preavviso. • The pictures are purely representative. The manufacturer reserves the right to modify the technical data and models without previous notice. • Les images

LO

présentées ne nous engagent pas. La Société se réserve le droit d'apporter tout modification sans préavis. • Die dargestellten Abbildungen sind nicht verbindlich. Technische Änderungen vorbehalten. • Las imágenes presentadas no son vinculantes. El Fabricante se reserva el derecho de modificar sus productos sin previo aviso.

01/20

153

70



MOD. \_\_\_\_\_  
COD. \_\_\_\_\_

DESCRIZIONE/DESCRIPTION/BEZEICHNUNG/DESCRIPTION/DESCRIPCIÓN  
DIMENSIONI/DIMENSIONS/ABMESSUNGEN/DIMENSIONS/DIMENSIONES

POTENZA/POWER/LEISTUNG/PUISSANCE/POTENCIA  
VOLTAGGIO/VOLTAGE/SPANNUNG/VOLTAGE/VOLTAJE

⚡ kW  
kcal/h

⚡ kW  
V~  
Hz

PREZZO/PRICE €  
PREIS/PRIX/PRECIO €  
KG / M<sup>3</sup>

**FTR-74GS**  
08230456

**FRY-TOP GAS RIGATO CROMATO SUPERCHROME (MOCA APPROVED), SU MOBILE A GIORNO, PIASTRA CM.36X51 (INCLUSA 1 TESTATA CHIUSURA PIANO MOD. TPA-7)**

**EN** Gas Fry-top grooved chromed griddle SUPERCHROME (Moca Approved), on open cabinet, plate cm.36x51 (included 1 Head end filler strip mod. TPA-7) • **DE** Gas-griddleplatte gerillt hartverchromt SUPERCHROME (Moca Approved), mit offenem Unterbau, platte cm.36x51 (inbegriffen 1 Abschluss-Element mod.TPA-7) • **FR** Plaque gaz nervurée chromée SUPERCHROME (Moca Approved), sur armoire ouvert, plaque cm.36x51 (inclus 1 Élément de jonction top mod.TPA-7) • **ES** Fry-top gas estriado cromado SUPERCHROME (Moca Approved), sobre mueble abierto, plancha cm.36x51 (incluida 1 Chapa de cierre para top mod.TPA-7)  
**cm. 40x 70,5x 90h**

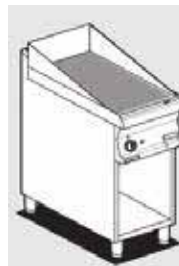

⚡ 7 kW  
6.020 kcal/h

**2.244,00**  
69 / 0,37

**FTL-76G**  
08230651

**FRY-TOP GAS LISCIO, SU MOBILE A GIORNO, PIASTRA CM.56X51 (INCLUSA 1 TESTATA CHIUSURA PIANO MOD.TPA-7)**

**EN** Gas Fry-top smooth griddle, on open cabinet, plate cm.56x51 (included 1 Head end filler strip mod.TPA-7) • **DE** Gas-griddleplatte glatt, mit offenem Unterbau, platte cm.56x51 (inbegriffen 1 Abschluss-Element mod. TPA-7) • **FR** Plaque gaz lisse, sur armoire ouvert, plaque cm.56x51 (inclus 1 Élément de jonction top mod. TPA-7) • **ES** Fry-top gas liso, sobre mueble abierto, plancha cm.56x51 (incluida 1 Chapa de cierre para top mod.TPA-7)  
**cm. 60x 70,5x 90h**



⚡ 10,5 kW  
9.030 kcal/h

**2.094,00**  
83 / 0,54

**FTL-76GS**  
08230654

**FRY-TOP GAS LISCIO CROMATO SUPERCHROME (MOCA APPROVED), SU MOBILE A GIORNO, PIASTRA CM.56X51 (INCLUSA 1 TESTATA CHIUSURA PIANO MOD. TPA-7)**

**EN** Gas Fry-top smooth chromed griddle SUPERCHROME (Moca Approved), on open cabinet, plate cm.56x51 (included 1 Head end filler strip mod. TPA-7) • **DE** Gas-griddleplatte glatt hartverchromt SUPERCHROME (Moca Approved), mit offenem Unterbau, platte cm.56x51 (inbegriffen 1 Abschluss-Element mod.TPA-7) • **FR** Plaque gaz lisse chromée SUPERCHROME (Moca Approved), sur armoire ouvert, plaque cm.56x51 (inclus 1 Élément de jonction top mod. TPA-7) • **ES** Fry-top gas liso cromado SUPERCHROME (Moca Approved), sobre mueble abierto, plancha cm.56x51 (incluida 1 Chapa de cierre para top mod. TPA-7)  
**cm. 60x 70,5x 90h**

⚡ 10,5 kW  
9.030 kcal/h

**2.552,00**  
83 / 0,54

**FTLR-76G**  
08230652

**FRY-TOP GAS 1/2 RIGATO + 1/2 LISCIO, SU MOBILE A GIORNO, PIASTRA CM.56X51 (INCLUSA 1 TESTATA CHIUSURA PIANO MOD. TPA-7)**

**EN** Gas Fry-top 1/2 grooved + 1/2 smooth, on open cabinet, plate cm.56x51 (included 1 Head end filler strip mod.TPA-7) • **DE** Gas-griddleplatte 1/2 gerillt + 1/2 glatt, mit offenem Unterbau, platte cm.56x51 (inbegriffen 1 Abschluss-Element mod.TPA-7) • **FR** Plaque gaz 1/2 nervurée + 1/2 lisse, sur armoire ouvert, plaque cm.56x51 (inclus 1 Élément de jonction top mod.TPA-7) • **ES** Fry-top gas 1/2 estriado + 1/2 liso, sobre mueble abierto, plancha cm.56x51 (incluida 1 Chapa de cierre para top mod.TPA-7)  
**cm. 60x 70,5x 90h**



⚡ 10,5 kW  
9.030 kcal/h

**2.198,00**  
83 / 0,54

MOD. \_\_\_\_\_  
COD. \_\_\_\_\_

DESCRIZIONE/DESCRIPTION/BEZEICHNUNG/DESCRIPTION/DESCRIPCIÓN  
DIMENSIONI/DIMENSIONS/ABMESSUNGEN/DIMENSIONS/DIMENSIONES

POTENZA/POWER/LEISTUNG/PUISSANCE/POTENCIA  
VOLTAGGIO/VOLTAGE/SPANNUNG/VOLTAGE/VOLTAJE

10,5 kW  
9.030 kcal/h

PREZZO/PRICE €  
83 / 0,54  
KG / M<sup>3</sup>

**FTLR-76GS**  
08230655

**FRY-TOP GAS 1/2 RIGATO + 1/2 LISCIO CROMATO SUPERCHROME (MOCA APPROVED), SU MOBILE A GIORNO, PIASTRA CM.56X51 (INCLUSA 1 TESTATA CHIUSURA PIANO MOD.TPA-7)**

**EN** Gas Fry-top 1/2 grooved + 1/2 smooth chromed griddle SUPERCHROME (Moca Approved), on open cabinet, plate cm.56x51 (included 1 Head end filler strip mod.TPA-7) • **DE** Gas-griddleplatte 1/2 gerillt + 1/2 glatt hartverchromt SUPERCHROME (Moca Approved), mit offenem Unterbau, platte cm.56x51 (inbegriffen 1 Abschluss-Element mod.TPA-7) • **FR** Plaque gaz 1/2 nervurée + 1/2 lisse chromée SUPERCHROME (Moca Approved), sur armoire ouvert, plaque cm.56x51 (inclus 1 Élément de jonction top mod.TPA-7) • **ES** Fry-top gas 1/2 estriado + 1/2 liso cromado SUPERCHROME (Moca Approved), sobre mueble abierto, plancha cm.56x51 (incluida 1 Chapa de cierre para top mod.TPA-7)

**cm. 60x 70,5x 90h**



10,5 kW  
9.030 kcal/h

**2.658,00**  
83 / 0,54



**FTR-76G**  
08230653

**FRY-TOP GAS RIGATO, SU MOBILE A GIORNO, PIASTRA CM.56X51 (INCLUSA 1 TESTATA CHIUSURA PIANO MOD.TPA-7)**

**EN** Gas Fry-top grooved griddle, on open cabinet, plate cm.56x51 (included 1 Head end filler strip mod.TPA-7) • **DE** Gas-griddleplatte gerillt, mit offenem Unterbau, platte cm.56x51 (inbegriffen 1 Abschluss-Element mod.TPA-7) • **FR** Plaque gaz nervurée, sur armoire ouvert, plaque cm.56x51 (inclus 1 Élément de jonction top mod.TPA-7) • **ES** Fry-top gas estriado, sobre mueble abierto, plancha cm.56x51 (incluida 1 Chapa de cierre para top mod.TPA-7)

**cm. 60x 70,5x 90h**



10,5 kW  
9.030 kcal/h

**2.290,00**  
83 / 0,54



**FTR-76GS**  
08230656

**FRY-TOP GAS RIGATO CROMATO SUPERCHROME (MOCA APPROVED), SU MOBILE A GIORNO, PIASTRA CM.56X51 (INCLUSA 1 TESTATA CHIUSURA PIANO MOD.TPA-7)**

**EN** Gas Fry-top grooved chromed griddle SUPERCHROME (Moca Approved), on open cabinet, plate cm.56x51 (included 1 Head end filler strip mod.TPA-7) • **DE** Gas-griddleplatte gerillt hartverchromt SUPERCHROME (Moca Approved), mit offenem Unterbau, platte cm.56x51 (inbegriffen 1 Abschluss-Element mod.TPA-7) • **FR** Plaque gaz nervurée chromée SUPERCHROME (Moca Approved), sur armoire ouvert, plaque cm.56x51 (inclus 1 Élément de jonction top mod.TPA-7) • **ES** Fry-top gas estriado cromado SUPERCHROME (Moca Approved), sobre mueble abierto, plancha cm.56x51 (incluida 1 Chapa de cierre para top mod.TPA-7)

**cm. 60x 70,5x 90h**

10,5 kW  
9.030 kcal/h

**2.744,00**  
83 / 0,54



**FTL-78G**  
08230851

**FRY-TOP GAS LISCIO, SU MOBILE A GIORNO, PIASTRA CM.76X51 - 2 ZONE DI COTTURA (INCLUSA 1 TESTATA CHIUSURA PIANO MOD.TPA-7)**

**EN** Gas Fry-top smooth griddle, on open cabinet, plate cm.76x51 - 2 cooking areas (included 1 Head end filler strip mod.TPA-7) • **DE** Gas-griddleplatte glatt, mit offenem Unterbau, platte cm.76x51 - 2 Heizzonen (inbegriffen 1 Abschluss-Element mod.TPA-7) • **FR** Plaque gaz lisse, sur armoire ouvert, plaque cm.76x51 - 2 zones de cuisson (inclus 1 Élément de jonction top mod.TPA-7) • **ES** Fry-top gas liso, sobre mueble abierto, plancha cm.76x51 - 2 zonas de cocción (incluida 1 Chapa de cierre para top mod.TPA-7)

**cm. 80x 70,5x 90h**



14 kW  
12.040 kcal/h

**2.877,00**  
114 / 0,71

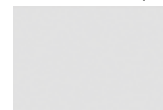

MOD. \_\_\_\_\_  
COD. \_\_\_\_\_

DESCRIZIONE/DESCRIPTION/BEZEICHNUNG/DESCRIPTION/DESCRIPCIÓN  
DIMENSIONI/DIMENSIONS/ABMESSUNGEN/DIMENSIONS/DIMENSIONES

POTENZA/POWER/LEISTUNG/PUISSANCE/POTENCIA  
VOLTAGGIO/VOLTAGE/SPANNUNG/VOLTAGE/VOLTAJE

14 kW  
12.040 kcal/h

PREZZO/PRICE €  
114 / 0,71  
KG / M<sup>3</sup>

**FTL-78GS**  
08230854

**FRY-TOP GAS LISCIO CROMATO SUPERCHROME (MOCA APPROVED), SU MOBILE A GIORNO, PIASTRA CM.76X51 - 2 ZONE DI COTTURA (INCLUSA 1 TESTATA CHIUSURA PIANO MOD.TPA-7)**

**EN** Gas Fry-top smooth chromed griddle SUPERCHROME (Moca Approved), on open cabinet, plate cm.76x51 - 2 cooking areas (included 1 Head end filler strip mod.TPA-7) • **DE** Gas-griddleplatte glatt hartverchromt SUPERCHROME (Moca Approved), mit offenem Unterbau, platte cm.76x51 - 2 Heizzonen (inbegriffen 1 Abschluss-Element mod.TPA-7) • **FR** Plaque gaz lisse chromée SUPERCHROME (Moca Approved), sur armoire ouvert, plaque cm.76x51 - 2 zones de cuisson (inclus 1 Élément de jonction top mod.TPA-7) • **ES** Fry-top gas liso cromado SUPERCHROME (Moca Approved), sobre mueble abierto, plancha cm.76x51 - 2 zonas de cocción (incluida 1 Chapa de cierre para top mod.TPA-7)  
**cm. 80x 70,5x 90h**



14 kW  
12.040 kcal/h

**3.396,00**  
114 / 0,71

**FTLR-78G**  
08230852

**FRY-TOP GAS 1/2 RIGATO + 1/2 LISCIO, SU MOBILE A GIORNO, PIASTRA CM.76X51 - 2 ZONE DI COTTURA (INCLUSA 1 TESTATA CHIUSURA PIANO MOD.TPA-7)**

**EN** Gas Fry-top 1/2 grooved + 1/2 smooth, on open cabinet, plate cm.76x51 - 2 cooking areas (included 1 Head end filler strip mod.TPA-7) • **DE** Gas-griddleplatte 1/2 gerillt + 1/2 glatt, mit offenem Unterbau, platte cm.76x51 - 2 Heizzonen (inbegriffen 1 Abschluss-Element mod.TPA-7) • **FR** Plaque gaz 1/2 nervurée + 1/2 lisse, sur armoire ouvert, plaque cm.76x51 - 2 zones de cuisson (inclus 1 Élément de jonction top mod.TPA-7) • **ES** Fry-top gas 1/2 estriado + 1/2 liso, sobre mueble abierto, plancha cm.76x51 - 2 zonas de cocción (incluida 1 Chapa de cierre para top mod.TPA-7)  
**cm. 80x 70,5x 90h**



14 kW  
12.040 kcal/h

**3.022,00**  
114 / 0,71

**FTLR-78GS**  
08230855

**FRY-TOP GAS 1/2 RIGATO + 1/2 LISCIO CROMATO SUPERCHROME (MOCA APPROVED), SU MOBILE A GIORNO, PIASTRA CM.76X51 - 2 ZONE DI COTTURA (INCLUSA 1 TESTATA CHIUSURA PIANO MOD.TPA-7)**

**EN** Gas Fry-top 1/2 grooved + 1/2 smooth chromed griddle SUPERCHROME (Moca Approved), on open cabinet, plate cm.76x51 - 2 cooking areas (included 1 Head end filler strip mod.TPA-7) • **DE** Gas-griddleplatte 1/2 gerillt + 1/2 glatt hartverchromt SUPERCHROME (Moca Approved), mit offenem Unterbau, platte cm.76x51 - 2 Heizzonen (inbegriffen 1 Abschluss-Element mod.TPA-7) • **FR** Plaque gaz 1/2 nervurée + 1/2 lisse chromée SUPERCHROME (Moca Approved), sur armoire ouvert, plaque cm.76x51 - 2 zones de cuisson (inclus 1 Élément de jonction top mod.TPA-7) • **ES** Fry-top gas 1/2 estriado + 1/2 liso cromado SUPERCHROME (Moca Approved), sobre mueble abierto, plancha cm.76x51 - 2 zonas de cocción (incluida 1 Chapa de cierre para top mod.TPA-7)  
**cm. 80x 70,5x 90h**



14 kW  
12.040 kcal/h

**3.543,00**  
114 / 0,71

MOD. \_\_\_\_\_  
COD. \_\_\_\_\_

DESCRIZIONE/DESCRIPTION/BEZEICHNUNG/DESCRIPTION/DESCRIPCIÓN  
DIMENSIONI/DIMENSIONS/ABMESSUNGEN/DIMENSIONS/DIMENSIONES

POTENZA/POWER/LEISTUNG/PUISSANCE/POTENCIA  
VOLTAGGIO/VOLTAGE/SPANNUNG/VOLTAGE/VOLTAJE

14 kW  
12.040 kcal/h

PREZZO/PRICE €  
PREIS/PRIX/PRECIO €  
KG / M<sup>3</sup>

**FTR-78G**  
08230853

**FRY-TOP GAS RIGATO, SU MOBILE A GIORNO, PIASTRA CM.76X51 - 2 ZONE DI COTTURA (INCLUSA 1 TESTATA CHIUSURA PIANO MOD. TPA-7)**

**EN** Gas Fry-top grooved griddle, on open cabinet, plate cm.76x51 - 2 cooking areas (included 1 Head end filler strip mod.TPA-7) • **DE** Gas-griddleplatte gerillt, mit offenem Unterbau, platte cm.76x51 - 2 Heizzonen (inbegriffen 1 Abschluss-Element mod.TPA-7) • **FR** Plaque gaz nervurée, sur armoire ouvert, plaque cm.76x51 - 2 zones de cuisson (inclus 1 Élément de jonction top mod.TPA-7) • **ES** Fry-top gas estriado, sobre mueble abierto, plancha cm.76x51 - 2 zonas de cocción (incluida 1 Chapa de cierre para top mod. TPA-7)

**cm. 80x 70,5x 90h**



14 kW  
12.040 kcal/h

**3.162,00**  
114 / 0,71



**FTR-78GS**  
08230856

**FRY-TOP GAS RIGATO CROMATO SUPERCHROME (MOCA APPROVED), SU MOBILE A GIORNO, PIASTRA CM.76X51 - 2 ZONE DI COTTURA (INCLUSA 1 TESTATA CHIUSURA PIANO MOD.TPA-7)**

**EN** Gas Fry-top grooved chromed griddle SUPERCHROME (Moca Approved), on open cabinet, plate cm.76x51 - 2 cooking areas (included 1 Head end filler strip mod.TPA-7) • **DE** Gas-griddleplatte gerillt hartverchromt SUPERCHROME (Moca Approved), mit offenem Unterbau, platte cm.76x51 - 2 Heizzonen (inbegriffen 1 Abschluss-Element mod.TPA-7) • **FR** Plaque gaz nervurée chromée SUPERCHROME (Moca Approved), sur armoire ouvert, plaque cm.76x51 - 2 zones de cuisson (inclus 1 Élément de jonction top mod.TPA-7) • **ES** Fry-top gas estriado cromado SUPERCHROME (Moca Approved), sobre mueble abierto, plancha cm.76x51 - 2 zonas de cocción (incluida 1 Chapa de cierre para top mod.TPA-7)

**cm. 80x 70,5x 90h**

14 kW  
12.040 kcal/h

**3.698,00**  
114 / 0,71



**FTL-712G**  
08231251

**FRY-TOP GAS LISCIO, SU MOBILE A GIORNO, PIASTRA CM.116X51 - 2 ZONE DI COTTURA (INCLUSA 1 TESTATA CHIUSURA PIANO MOD. TPA-7)**

**EN** Gas Fry-top smooth griddle, on open cabinet, plate cm.116x51 - 2 cooking areas (included 1 Head end filler strip mod.TPA-7) • **DE** Gas-griddleplatte glatt, mit offenem Unterbau, platte cm.116x51 - 2 Heizzonen (inbegriffen 1 Abschluss-Element mod.TPA-7) • **FR** Plaque gaz lisse, sur armoire ouvert, plaque cm.116x51 - 2 zones de cuisson (inclus 1 Élément de jonction top mod.TPA-7) • **ES** Fry-top gas liso, sobre mueble abierto, plancha cm.116x51 - 2 zonas de cocción (incluida 1 Chapa de cierre para top mod.TPA-7)

**cm. 120x 70,5x 90h**



21 kW  
18.060 kcal/h

**3.626,00**  
154 / 1,05



**FTL-712GS**  
08231254

**FRY-TOP GAS LISCIO CROMATO SUPERCHROME (MOCA APPROVED), SU MOBILE A GIORNO, PIASTRA CM.116X51 - 2 ZONE DI COTTURA (INCLUSA 1 TESTATA CHIUSURA PIANO MOD.TPA-7)**

**EN** Gas Fry-top smooth chromed griddle SUPERCHROME (Moca Approved), on open cabinet, plate cm.116x51 - 2 cooking areas (included 1 Head end filler strip mod.TPA-7) • **DE** Gas-griddleplatte glatt hartverchromt SUPERCHROME (Moca Approved), mit offenem Unterbau, platte cm.116x51 - 2 Heizzonen (inbegriffen 1 Abschluss-Element mod.TPA-7) • **FR** Plaque gaz lisse chromée SUPERCHROME (Moca Approved), sur armoire ouvert, plaque cm.116x51 - 2 zones de cuisson (inclus 1 Élément de jonction top mod. TPA-7) • **ES** Fry-top gas liso cromado SUPERCHROME (Moca Approved), sobre mueble abierto, plancha cm.116x51 - 2 zonas de cocción (incluida 1 Chapa de cierre para top mod.TPA-7)

**cm. 120x 70,5x 90h**

21 kW  
18.060 kcal/h

**4.282,00**  
154 / 1,05

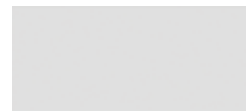

MOD. \_\_\_\_\_  
COD. \_\_\_\_\_

DESCRIZIONE/DESCRIPTION/BEZEICHNUNG/DESCRIPTION/DESCRIPCIÓN  
DIMENSIONI/DIMENSIONS/ABMESSUNGEN/DIMENSIONS/DIMENSIONES

POTENZA/POWER/LEISTUNG/PUISSANCE/POTENCIA  
VOLTAGGIO/VOLTAGE/SPANNUNG/VOLTAGE/VOLTAJE

⚡ kW  
18.060 kcal/h

⚡ kW  
V~  
Hz

PREZZO/PRICE €  
PREIS/PRIX/PRECIO €  
KG / M<sup>3</sup>

**FTLR-712G**  
08231252

**FRY-TOP GAS 1/2 RIGATO + 1/2 LISCIO, SU MOBILE A GIORNO, PIASTRA CM.116X51 - 2 ZONE DI COTTURA (INCLUSA 1 TESTATA CHIUSURA PIANO MOD.TPA-7)**

**EN** Gas Fry-top 1/2 grooved + 1/2 smooth, on open cabinet, plate cm.116x51 - 2 cooking areas (included 1 Head end filler strip mod.TPA-7) • **DE** Gas-griddleplatte 1/2 gerillt + 1/2 glatt, mit offenem Unterbau, platte cm.116x51 - 2 Heizzonen (inbegriffen 1 Abschluss-Element mod.TPA-7) • **FR** Plaque gaz 1/2 nervurée + 1/2 lisse, sur armoire ouvert, plaque cm.116x51 - 2 zones de cuisson (inclus 1 Élément de jonction top mod.TPA-7) • **ES** Fry-top gas 1/2 estriado + 1/2 liso, sobre mueble abierto, plancha cm.116x51 - 2 zonas de cocción (incluida 1 Chapa de cierre para top mod.TPA-7)

**cm. 120x 70,5x 90h**



⚡ 21 kW  
18.060 kcal/h

**3.808,00**  
154 / 1,05



**FTLR-712GS**  
08231255

**FRY-TOP GAS 1/2 RIGATO + 1/2 LISCIO CROMATO SUPERCHROME (MOCA APPROVED), SU MOBILE A GIORNO, PIASTRA CM.116X51 - 2 ZONE DI COTTURA (INCLUSA 1 TESTATA CHIUSURA PIANO MOD.TPA-7)**

**EN** Gas Fry-top 1/2 grooved + 1/2 smooth chromed griddle SUPERCHROME (Moca Approved), on open cabinet, plate cm.116x51 - 2 cooking areas (included 1 Head end filler strip mod.TPA-7) • **DE** Gas-griddleplatte 1/2 gerillt + 1/2 glatt hartverchromt SUPERCHROME (Moca Approved), mit offenem Unterbau, platte cm.116x51 - 2 Heizzonen (inbegriffen 1 Abschluss-Element mod.TPA-7) • **FR** Plaque gaz 1/2 nervurée + 1/2 lisse chromée SUPERCHROME (Moca Approved), sur armoire ouvert, plaque cm.116x51 - 2 zones de cuisson (inclus 1 Élément de jonction top mod.TPA-7)

• **ES** Fry-top gas 1/2 estriado + 1/2 liso cromado SUPERCHROME (Moca Approved), sobre mueble abierto, plancha cm.116x51 - 2 zonas de cocción (incluida 1 Chapa de cierre para top mod.TPA-7)

**cm. 120x 70,5x 90h**

⚡ 21 kW  
18.060 kcal/h

**4.431,00**  
154 / 1,05



**FTR-712G**  
08231253

**FRY-TOP GAS RIGATO, SU MOBILE A GIORNO, PIASTRA CM.116X51 - 2 ZONE DI COTTURA (INCLUSA 1 TESTATA CHIUSURA PIANO MOD.TPA-7)**

**EN** Gas Fry-top grooved griddle, on open cabinet, plate cm.116x51 - 2 cooking areas (included 1 Head end filler strip mod.TPA-7) • **DE** Gas-griddleplatte gerillt, mit offenem Unterbau, platte cm.116x51 - 2 Heizzonen (inbegriffen 1 Abschluss-Element mod.TPA-7) • **FR** Plaque gaz nervurée, sur armoire ouvert, plaque cm.116x51 - 2 zones de cuisson (inclus 1 Élément de jonction top mod.TPA-7) • **ES** Fry-top gas estriado, sobre mueble abierto, plancha cm.116x51 - 2 zonas de cocción (incluida 1 Chapa de cierre para top mod.TPA-7)

**cm. 120x 70,5x 90h**



⚡ 21 kW  
18.060 kcal/h

**3.992,00**  
154 / 1,05





MOD. \_\_\_\_\_  
COD. \_\_\_\_\_

DESCRIZIONE/DESCRIPTION/BEZEICHNUNG/DESCRIPTION/DESCRIPCIÓN  
DIMENSIONI/DIMENSIONS/ABMESSUNGEN/DIMENSIONS/DIMENSIONES

POTENZA/POWER/LEISTUNG/PUISSANCE/POTENCIA  
VOLTAGGIO/VOLTAGE/SPANNUNG/VOLTAGE/VOLTAJE

⚡ 21 kW  
18.060 kcal/h

PREZZO/PRICE €  
PREIS/PRIX/PRECIO €  
KG / M<sup>3</sup>

**FTR-712GS**  
08231256

**FRY-TOP GAS RIGATO CROMATO SUPERCHROME (MOCA APPROVED), SU MOBILE A GIORNO, PIASTRA CM.116X51 - 2 ZONE DI COTTURA (INCLUSA 1 TESTATA CHIUSURA PIANO MOD.TPA-7)**

**EN** Gas Fry-top grooved chromed griddle SUPERCHROME (Moca Approved), on open cabinet, plate cm.116x51 - 2 cooking areas (included 1 Head end filler strip mod.TPA-7) • **DE** Gas-griddleplatte gerillt hartverchromt SUPERCHROME (Moca Approved), mit offenem Unterbau, platte cm.116x51 - 2 Heizzonen (inbegriffen 1 Abschluss-Element mod.TPA-7) • **FR** Plaque gaz nervurée chromée SUPERCHROME (Moca Approved), sur armoire ouvert, plaque cm.116x51 - 2 zones de cuisson (inclus 1 Élément de jonction top mod.TPA-7) • **ES** Fry-top gas estriado cromado SUPERCHROME (Moca Approved), sobre mueble abierto, plancha cm.116x51 - 2 zonas de cocción (incluida 1 Chapa de cierre para top mod.TPA-7)  
**cm. 120x 70,5x 90h**



⚡ 21 kW  
18.060 kcal/h

**4.626,00**  
154 / 1,05

**FTL-712G3**  
0823125B

**FRY-TOP GAS LISCIO, SU MOBILE A GIORNO, PIASTRA CM.116X51 - 3 ZONE DI COTTURA (INCLUSA 1 TESTATA CHIUSURA PIANO MOD. TPA-7)**

**EN** Gas Fry-top smooth griddle, on open cabinet, plate cm.116x51 - 3 cooking areas (included 1 Head end filler strip mod.TPA-7) • **DE** Gas-griddleplatte glatt, mit offenem Unterbau, platte cm.116x51 - 3 Heizzonen (inbegriffen 1 Abschluss-Element mod.TPA-7) • **FR** Plaque gaz lisse, sur armoire ouvert, plaque cm.116x51 - 3 zones de cuisson (inclus 1 Élément de jonction top mod.TPA-7) • **ES** Fry-top gas liso, sobre mueble abierto, plancha cm.116x51 - 3 zonas de cocción (incluida 1 Chapa de cierre para top mod.TPA-7)  
**cm. 120x 70,5x 90h**



⚡ 21 kW  
18.060 kcal/h

**3.905,00**  
154 / 1,05

**FTL-712GS3**  
0823125E

**FRY-TOP GAS LISCIO CROMATO SUPERCHROME (MOCA APPROVED), SU MOBILE A GIORNO, PIASTRA CM.116X51 - 3 ZONE DI COTTURA (INCLUSA 1 TESTATA CHIUSURA PIANO MOD.TPA-7)**

**EN** Gas Fry-top smooth chromed griddle SUPERCHROME (Moca Approved), on open cabinet, plate cm.116x51 - 3 cooking areas (included 1 Head end filler strip mod.TPA-7) • **DE** Gas-griddleplatte glatt hartverchromt SUPERCHROME (Moca Approved), mit offenem Unterbau, platte cm.116x51 - 3 Heizzonen (inbegriffen 1 Abschluss-Element mod.TPA-7) • **FR** Plaque gaz lisse chromée SUPERCHROME (Moca Approved), sur armoire ouvert, plaque cm.116x51 - 3 zones de cuisson (inclus 1 Élément de jonction top mod.TPA-7) • **ES** Fry-top gas liso cromado SUPERCHROME (Moca Approved), sobre mueble abierto, plancha cm.116x51 - 3 zonas de cocción (incluida 1 Chapa de cierre para top mod.TPA-7)  
**cm. 120x 70,5x 90h**

⚡ 21 kW  
18.060 kcal/h

**4.546,00**  
154 / 1,05

**FTLR-712G3**  
0823125C

**FRY-TOP GAS 1/3 RIGATO + 2/3 LISCIO, SU MOBILE A GIORNO, PIASTRA CM.116X51 - 3 ZONE DI COTTURA (INCLUSA 1 TESTATA CHIUSURA PIANO MOD.TPA-7)**

**EN** Gas Fry-top 1/3 grooved + 2/3 smooth, on open cabinet, plate cm.116x51 - 3 cooking areas (included 1 Head end filler strip mod.TPA-7) • **DE** Gas-griddleplatte 1/3 gerillt + 2/3 glatt, mit offenem Unterbau, platte cm.116x51 - 3 Heizzonen (inbegriffen 1 Abschluss-Element mod.TPA-7) • **FR** Plaque gaz 1/3 nervurée + 2/3 lisse, sur armoire ouvert, plaque cm.116x51 - 3 zones de cuisson (inclus 1 Élément de jonction top mod.TPA-7) • **ES** Fry-top gas 1/3 estriado + 2/3 liso, sobre mueble abierto, plancha cm.116x51 - 3 zonas de cocción (incluida 1 Chapa de cierre para top mod.TPA-7)  
**cm. 120x 70,5x 90h**



⚡ 21 kW  
18.060 kcal/h

**3.999,00**  
154 / 1,05



Le immagini presentate non sono vincolanti. La ditta si riserva di apportare modifiche senza preavviso. • The pictures are purely representative. The manufacturer reserves the right to modify the technical data and models without previous notice. • Les images

LO

présentées ne nous engagent pas. La Société se réserve le droit d'apporter tout modification sans préavis. • Die dargestellten Abbildungen sind nicht verbindlich. Technische Änderungen vorbehalten. • Las imágenes presentadas no son vinculantes. El Fabricante se reserva el derecho de modificar sus productos sin previo aviso.

01/20

159

70

MOD. \_\_\_\_\_  
COD. \_\_\_\_\_

DESCRIZIONE/DESCRIPTION/BEZEICHNUNG/DESCRIPTION/DESCRIPCIÓN  
DIMENSIONI/DIMENSIONS/ABMESSUNGEN/DIMENSIONS/DIMENSIONES

POTENZA/POWER/LEISTUNG/PUISSANCE/POTENCIA  
VOLTAGGIO/VOLTAGE/SPANNUNG/VOLTAGE/VOLTAJE

⚡ kW  
kcal/h

⚡ kw  
V~  
Hz

PREZZO/PRICE €  
PREIS/PRIX/PRECIO €  
KG / M<sup>3</sup>

**FTLR-712GS3 FRY-TOP GAS 1/3 RIGATO + 2/3 LISCIO CROMATO SUPERCHROME (MOCA APPROVED), SU MOBILE A GIORNO, PIASTRA CM.116X51 - 3 ZONE DI COTTURA (INCLUSA 1 TESTATA CHIUSURA PIANO MOD.TPA-7)**

**EN** Gas Fry-top 1/3 grooved + 2/3 smooth chromed SUPERCHROME (Moca Approved), on open cabinet, plate cm.116x51 - 3 cooking areas (included 1 Head end filler strip mod.TPA-7) • **DE** Gas-griddleplatte 1/3 gerillt + 2/3 glatt hartverchromt SUPERCHROME (Moca Approved), mit offenem Unterbau, platte cm.116x51 - 3 Heizzonen (inbegriffen 1 Abschluss-Element mod.TPA-7) • **FR** Plaque gaz 1/3 nervurée + 2/3 lisse chromée AW770:AW833approved), sur armoire ouvert, plaque cm.116x51 - 3 zones de cuisson (inclus 1 Élément de jonction top mod.TPA-7) • **ES** Fry-top gas 1/3 estriado + 2/3 liso cromado SUPERCHROME (Moca Approved), sobre mueble abierto, plancha cm.116x51 - 3 zonas de cocción (incluida 1 Chapa de cierre para top mod.TPA-7)  
**cm. 120x 70,5x 90h**



⚡ 21 kW  
18.060 kcal/h

**4.699,00**  
154 / 1,05



**RSFT-73EM PIASTRA PER SANDWICH SOPRA FRYTOP ELETTRICI - PIASTRA CM. 29X40 (ATTENZIONE: PROFONDITA' MACCHINA +CM.10)**

**EN** Sandwiches plate above electric griddle - plate cm. 29x40 (ATTENTION: DEPTH MACHINE +cm.10) • **DE** Sandwiches Platte über Elektrische Griddle - platte cm. 29x40 (VORSICHT: TIEFE MACHINE +cm.10) • **FR** Plaque pour sandwich au-dessus électrique fry-top - plaque cm. 29x40 (ATTENTION: PROFONDEUR MACHINE +cm.10) • **ES** Plancia para sándwiches sobre fry-top eléctrico - plancia cm. 29x40 (ATENCIÓN: PROFUNDIDAD MÁQUINA +cm.10)  
**cm. 32x 62x 41h**



⚡ 2,9 KW  
230V~  
50/60 Hz

**970,00**  
20 / 0,21

**CWK-74ET GRIGLIA CONTACT SU MOBILE A GIORNO - COTTURA DIRETTA SU RESISTENZA IN ACCIAIO INOX CM. 27X43 RIBALTABILE (INCLUSA 1 TESTATA CHIUSURA PIANO MOD.TPA-7)**

**EN** CONTACT Grill threephase on open cabinet - rotatable stainless steel grill cm. 27x43 (included 1 Head end filler strip mod.TPA-7) • **DE** Wurstbrater dreiphasig KONTAKT mit offenem Unterbau - Drehbaren Heizelement aus Edelstahl cm. 27x43 (inbegriffen 1 Abschluss-Element mod.TPA-7) • **FR** Grillade triphase CONTACT sur armoire ouvert- Grille inox rotatif cm 27x43 (inclus 1 Élément de jonction top mod.TPA-7) • **ES** Parrilla trifásico CONTACT sobre mueble abierto - Parrilla giratoria de acero inox cm 27x43 (incluida 1 Chapa de cierre para top mod.TPA-7)  
**cm. 40x 70,5x 90h**



⚡ 4,08 KW  
400V~3N  
50/60 Hz

**2.570,00**  
60 / 0,37

**CWK-78ET GRIGLIA CONTACT SU MOBILE A GIORNO - COTTURA DIRETTA SU RESISTENZA IN ACCIAIO INOX CM. 55X43 RIBALTABILE - 2 ZONE COTTURA (INCLUSA 1 TESTATA CHIUSURA PIANO MOD.TPA-7)**

**EN** CONTACT Grill threephase on open cabinet - rotatable stainless steel grill cm. 55x43 - 2 cooking areas (included 1 Head end filler strip mod.TPA-7) • **DE** Wurstbrater dreiphasig KONTAKT mit offenem Unterbau - Drehbaren Heizelement aus Edelstahl cm. 55x43 - 2 Heizzonen (inbegriffen 1 Abschluss-Element mod.TPA-7) • **FR** Grillade triphase CONTACT sur armoire ouvert-Grille inox rotatif cm 55x43 - 2 zones de cuisson (inclus 1 Élément de jonction top mod.TPA-7) • **ES** Parrilla trifásico CONTACT sobre mueble abierto - Parrilla giratoria de acero inox cm 55x43 - 2 zonas de cocción (incluida 1 Chapa de cierre para top mod.TPA-7)  
**cm. 80x 70,5x 90h**



⚡ 8,16 KW  
400V~3N  
50/60 Hz

**3.320,00**  
90 / 0,71

MOD. \_\_\_\_\_  
COD. \_\_\_\_\_

DESCRIZIONE/DESCRIPTION/BEZEICHNUNG/DESCRIPTION/DESCRIPCIÓN  
DIMENSIONI/DIMENSIONS/ABMESSUNGEN/DIMENSIONS/DIMENSIONES

POTENZA/POWER/LEISTUNG/PUISSANCE/POTENCIA  
VOLTAGGIO/VOLTAGE/SPANNUNG/VOLTAGE/VOLTAJE

⚡ kW  
kcal/h

⚡ kW  
V~  
Hz

PREZZO/PRICE €  
PREIS/PRIX/PRECIO €  
KG / M<sup>3</sup>

**CW-74ET**  
08080430

**GRIGLIA TRIFASE SU MOBILE A GIORNO  
GRIGLIA IN ACCIAIO INOX CM. 38X52  
REGOLABILE (INCLUSA 1 TESTATA CHIUSURA  
PIANO MOD.TPA-7)**

**EN** Grill threephase on open cabinet Stainless steel grill cm. 38x52 (included 1 Head end filler strip mod.TPA-7)

• **DE** Wurstbrater dreiphasig mit offenem Unterbau Einstellbarer Rost aus Nirosa cm. 38x52 (inbegriffen 1 Abschluss-Element mod.TPA-7) • **FR** Grillade triphase sur armoire ouvert Grille inox cm 38x52 (inclus 1 Elément de jonction top mod.TPA-7) • **ES** Parrilla trifásico sobre mueble abierto Parrilla de acero inox regulable cm 38x52 (incluida 1 Chapa de cierre para top mod.TPA-7)

**cm. 40x 70,5x 90h**



⚡ 6 kW  
400V~3N  
230V~3  
50/60 Hz

**1.905,00**  
62 / 0,40

**CW-78ET**  
08080830

**GRIGLIA TRIFASE SU MOBILE A GIORNO N.  
2 GRIGLIE IN ACCIAIO INOX CM. 38X52  
REGOLABILI 2 ZONE DI COTTURA (INCLUSA 1  
TESTATA CHIUSURA PIANO MOD.TPA-7)**

**EN** Grill threephase on open cabinet N. 2 Stainless steel grill cm. 38x52. 2 cooking areas (included 1 Head end filler strip mod.TPA-7) • **DE** Wurstbrater dreiphasig mit offenem Unterbau - Nr. 2 einstellbare Roste aus Nirosa cm. 38x52 - 2 Heizzonen (inbegriffen 1 Abschluss-Element mod.TPA-7) • **FR** Grillade triphase sur armoire ouvert N. 2 grilles réglables en acier inox cm. 38x52 2 zones de cuisson (inclus 1 Elément de jonction top mod.TPA-7) • **ES** Parrilla trifásico sobre mueble abierto - N. 2 Parrillas de acero inox regulable cm 38x52 - 2 zonas de cocción (incluida 1 Chapa de cierre para top mod.TPA-7)

**cm. 80x 70,5x 90h**



⚡ 12 kW  
400V~3N  
230V~3  
50/60 Hz

**2.681,00**  
94 / 0,78

**CW-74G**  
08250450

**GRIGLIA GAS-PIETRALAVICA SU MOBILE A  
GIORNO GRIGLIA IN ACCIAIO INOX CM.  
38X52 REGOLABILE (INCLUSA 1 TESTATA  
CHIUSURA PIANO MOD.TPA-7)**

**EN** Charcoal grill gas on open cabinet Stainless steel grill cm. 38x52 (included 1 Head end filler strip mod.TPA-7) • **DE** Gas-Lavasteingrill mit offenem Unterbau Einstellbarer Rost aus Nirosa cm. 38x52 (inbegriffen 1 Abschluss-Element mod.TPA-7) • **FR** Grille à gaz en pierre de lave sur armoire ouvert Grille inox cm 38x52 (inclus 1 Elément de jonction top mod.TPA-7) • **ES** Parrilla a gas piedra lávica sobre mueble abierto Parrilla de acero inox regulable cm 38x52 (incluida 1 Chapa de cierre para top mod.TPA-7)

**cm. 40x 70,5x 90h**



⚡ 9 kW  
7.740 kcal/h

**2.002,00**  
61 / 0,40

**CW-78G**  
08250850

**GRIGLIA GAS-PIETRALAVICA SU MOBILE A  
GIORNO N. 2 GRIGLIE IN ACCIAIO INOX CM.  
38X52 REGOLABILI 2 ZONE DI COTTURA.  
(INCLUSA 1 TESTATA CHIUSURA PIANO MOD.  
TPA-7)**

**EN** Charcoal grill gas on open cabinet N. 2 Stainless steel grill cm. 38x52. 2 cooking areas (included 1 Head end filler strip mod.TPA-7) • **DE** Gas-Lavasteingrill mit offenem Unterbau - N. 2 einstellbare Roste aus Nirosa cm. 38x52 - 2 Heizzonen (inbegriffen 1 Abschluss-Element mod.TPA-7) • **FR** Grille a gaz en pierre de lave sur armoire ouvert. N. 2 grilles réglables en acier inox cm. 38x52. 2 zones de cuisson (inclus 1 Elément de jonction top mod.TPA-7) • **ES** Parrilla a gas piedra lávica sobre mueble abierto N. 2 Parrillas de acero inox regulable cm 38x52 2 zonas de cocción (incluida 1 Chapa de cierre para top mod.TPA-7)

**cm. 80x 70,5x 90h**



⚡ 18 kW  
15.480 kcal/h

**3.009,00**  
104 / 0,78

# FRIGGITRICI ELETTRICHE

MOD. \_\_\_\_\_  
COD. \_\_\_\_\_

DESCRIZIONE/DESCRIPTION/BEZEICHNUNG/DESCRIPTION/DESCRIPCIÓN  
DIMENSIONI/DIMENSIONS/ABMESSUNGEN/DIMENSIONS/DIMENSIONES

POTENZA/POWER/LEISTUNG/PUISSANCE/POTENCIA  
VOLTAGGIO/VOLTAGE/SPANNUNG/VOLTAGE/VOLTAJE

⚡ kW  
kcal/h  
V~  
Hz

PREZZO/PRICE €  
PREIS/PRIX/PRECIO  
KG / M<sup>3</sup>

**F2/8-74ET**  
08090432

**FRIGGITRICE TRIFASE LT. 8+8 2 VASCHE CM. 14,8X35X32,7H - 2 CESTI CM. 12X30X15H - FILTRO E COPERCHIO VASCA. 2 BACINELLE RACCOGLIOLIO CON FILTRO. PRODUZIONE PATATE: 12 KG/H (INCLUSA 1 TESTATA CHIUSURA PIANO MOD.TPA-7)**

**EN** Fryer threephase 8+8 lts - 2 Bowls cm. 14,8x35x32,7h - 2 baskets cm. 12x30x15h. Sieve and lid for pan. 2 drip tray with sieves. Production: 12 kg/h (included 1 Head end filler strip mod.TPA-7) • **DE** Friteuse dreiphasig lt. 8+8 - 2 Becken cm. 14,8x35x32,7h - 2 Korb cm. 12x30x15h. Einlegesieb und Deckel für Becken. 2 Fettauffangschalen mit Sieb. Pommes frites: 12 kg/h (inbegriffen 1 Abschluss-Element mod.TPA-7) • **FR** Friteuse triphase lt. 8+8 - 2 Cuve cm. 14,8x35x32,7h - 2 Panier cm. 12x30x15h. Filtre, couvercle pour cuve. 2 bacs de récupération de l'huile avec filtre. Production de pommes frites: 12 kg/h (inclus 1 Élément de jonction top mod.TPA-7) • **ES** Freidoras trifásico 8+8 lt. - 2Cuba cm. 14,8x35x32,7h - 2 cesta cm. 12x30x15h. Filtro y tapa para cuba. 2 bandejas recoge aceite con filtro. Prod. patatas: 12 Kg/h (incluida 1 Chapa de cierre para top mod.TPA-7)  
**cm. 40x 70,5x 90h**



⚡ 12 kW **2.722,00**  
400V~3N 59 / 0,37  
230V~3  
50/60 Hz

**F13-74ET**  
08090430

**FRIGGITRICE TRIFASE LT. 13 VASCA CM. 24X35X38H - 1 CESTO CM. 21X30X12H - FILTRO E COPERCHIO VASCA. BACINELLA RACCOGLIOLIO CON FILTRO. PRODUZIONE PATATE: 10 KG/H (INCLUSA 1 TESTATA CHIUSURA PIANO MOD.TPA-7)**

**EN** Fryer threephase 13 lts - Bowl cm. 24x35x38h - 1 basket cm. 21x30x12h. Sieve and lid for pan. Drip tray with sieve. Production: 10 kg/h (included 1 Head end filler strip mod.TPA-7) • **DE** Friteuse dreiphasig lt. 13 - Becken cm. 24x35x38h - 1 Korb cm. 21x30x12h. Einlegesieb und Deckel für Becken. Fettauffangschale mit Sieb. Pommes frites: 10 kg/h (inbegriffen 1 Abschluss-Element mod.TPA-7) • **FR** Friteuse triphase lt. 13 - Cuve cm. 24x35x38h - 1 Panier cm. 21x30x12h. Filtre, couvercle pour cuve. Bac de récupération de l'huile avec filtre. Production de pommes frites: 10 kg/h (inclus 1 Élément de jonction top mod.TPA-7) • **ES** Freidoras trifásico 13 lt. - Cuba cm. 24x35x38h - 1 cesta cm. 21x30x12h. Filtro y tapa para cuba. Bandeja recoge aceite con filtro. Prod. patatas: 10 Kg/h (incluida 1 Chapa de cierre para top mod.TPA-7)  
**cm. 40x 70,5x 90h**



⚡ 11,95 kW **1.961,00**  
400V~3N 54 / 0,37  
50/60 Hz

**F18-74ET**  
08090431

**FRIGGITRICE TRIFASE LT. 18 VASCA CM. 31X34X33H - 1 CESTO CM. 28X29X15H - FILTRO E COPERCHIO VASCA. BACINELLA RACCOGLIOLIO CON FILTRO. PRODUZIONE PATATE: 15 KG/H (INCLUSA 1 TESTATA CHIUSURA PIANO MOD.TPA-7)**

**EN** Fryer threephase 18 lts - Bowl cm. 31x34x33h - 1 basket cm. 28x29x15h. Sieve and lid for pan. Drip tray with sieve. Production: 15 kg/h (included 1 Head end filler strip mod.TPA-7) • **DE** Friteuse dreiphasig lt. 18 - Becken cm. 31x34x33h - 1 Korb cm. 28x29x15h. Einlegesieb und Deckel für Becken. Fettauffangschale mit Sieb. Pommes frites: 15 kg/h (inbegriffen 1 Abschluss-Element mod.TPA-7) • **FR** Friteuse triphase lt. 18 - Cuve cm. 31x34x33h - 1 Panier cm. 28x29x15h. Filtre, couvercle pour cuve. Bac de récupération de l'huile avec filtre. Production de pommes frites: 15 kg/h (inclus 1 Élément de jonction top mod.TPA-7) • **ES** Freidoras trifásico 18 lt. - Cuba cm. 31x34x33h - 1 cesta cm. 28x29x15h. Filtro y tapa para cuba. Bandeja recoge aceite con filtro. Prod. patatas: 15 Kg/h (incluida 1 Chapa de cierre para top mod.TPA-7)  
**cm. 40x 70,5x 90h**

⚡ 15,9 kW **2.124,00**  
400V~3N 57 / 0,37  
50/60 Hz



# FRIGGITRICI ELETTRICHE

MOD. \_\_\_\_\_  
COD. \_\_\_\_\_

DESCRIZIONE/DESCRIPTION/BEZEICHNUNG/DESCRIPTION/DESCRIPCIÓN  
DIMENSIONI/DIMENSIONS/ABMESSUNGEN/DIMENSIONS/DIMENSIONES

POTENZA/POWER/LEISTUNG/PUISSANCE/POTENCIA  
VOLTAGGIO/VOLTAGE/SPANNUNG/VOLTAGE/VOLTAJE

⚡ kW  
kcal/h  
V~  
Hz

PREZZO/PRICE €  
PREIS/PRIX/PRECIO €  
KG / M<sup>3</sup>

**F2/13-78ET** FRIGGITRICE TRIFASE LT. 13+13 2 VASCHE  
08090830 **CM. 24X35X38H - 2 CESTI CM. 21X30X12H**  
**2 FILTRI E COPERCHI VASCHE. 2 BACINELLE**  
**RACCOGLIOLIO CON FILTRO. PRODUZIONE**  
**PATATE: 20 KG/H (INCLUSA 1 TESTATA**  
**CHIUSURA PIANO MOD.TPA-7)**

**EN** Fryer threephase 13+13 lts - 2 pans cm. 24x35x38h  
2 baskets cm. 21x30x12h. 2 sieve and lids for pan. 2  
drip trays with sieves. Production: 20 kg/h (included  
1 Head end filler strip mod.TPA-7) • **DE** Friteuse  
dreiphasig lt. 13+13 - 2 Becken cm. 24x35x38h 2  
Körbe cm. 21x30x12h. Einlegesieb und Deckel für  
Becken. 2 Fettauffangschalen mit Sieb. Pommes frites: 20  
kg/h (inbegriffen 1 Abschluss-Element mod.TPA-7) • **FR**  
Friteuse triphase lt. 13+13 - 2 cuves cm. 24x35x38h 2  
paniers cm. 21x30x12h. 2 filtres, couvercles pour cuve.  
2 bacs de récupération de l'huile avec filtre. Production  
de pommes frites: 20 kg/h (inclus 1 Élément de jonction  
top mod.TPA-7) • **ES** Freidoras trifásico 13+13 lt. - 2  
cubas cm. 24x35x38h 2 cestas cm. 21x30x12h. 2 filtros  
y tapas para cubas. 2 bandejas recoge aceite con filtro.  
Prod. patatas: 20 Kg/h (incluida 1 Chapa de cierre  
para top mod.TPA-7)

**cm. 80x 70,5x 90h**



⚡ 23,9 kW **2.936,00**  
400V~3N 95 / 0,71  
50/60 Hz

**F2/18-78ET** FRIGGITRICE TRIFASE LT. 18+18 2 VASCHE  
08090831 **CM. 31X34X33H - 2 CESTI CM. 28X29X15H**  
**2 FILTRI E COPERCHI VASCHE. 2 BACINELLE**  
**RACCOGLIOLIO CON FILTRO. PRODUZIONE**  
**PATATE: 30 KG/H (INCLUSA 1 TESTATA**  
**CHIUSURA PIANO MOD.TPA-7)**

**EN** Fryer threephase 18+18 lts - 2 pans cm. 31x34x33h  
2 baskets cm. 28x29x15h. 2 sieve and lids for pan. 2  
drip trays with sieves. Production: 30 kg/h (included  
1 Head end filler strip mod.TPA-7) • **DE** Friteuse  
dreiphasig lt. 18+18 - 2 Becken cm. 31x34x33h 2  
Körbe cm. 28x29x15h. Einlegesieb und Deckel für  
Becken. 2 Fettauffangschalen mit Sieb. Pommes frites: 30  
kg/h (inbegriffen 1 Abschluss-Element mod.TPA-7) • **FR**  
Friteuse triphase lt. 18+18 - 2 cuves cm. 31x34x33h 2  
paniers cm. 28x29x15h. 2 filtres, couvercles pour cuve.  
2 bacs de récupération de l'huile avec filtre. Production  
de pommes frites: 30 kg/h (inclus 1 Élément de jonction  
top mod.TPA-7) • **ES** Freidoras trifásico 18+18 lt. - 2  
cubas cm. 31x34x33h 2 cestas cm. 28x29x15h. 2 filtros  
y tapas para cuba. 2 bandejas recoge aceite con filtro.  
Prod. patatas: 30 Kg/h (incluida 1 Chapa de cierre  
para top mod.TPA-7)

**cm. 80x 70,5x 90h**

⚡ 31,8 kW **3.266,00**  
400V~3N 97 / 0,71  
50/60 Hz

**F45-78ET** FRIGGITRICE TRIFASE LT. 45 VASCA CM.  
08090835 **70X38X38H - 1 CESTO CM. 65X33X17H**  
**- FILTRO E COPERCHIO VASCA. BACINELLA**  
**RACCOGLIOLIO CON FILTRO. PRODUZIONE**  
**PATATE: 40 KG/H (INCLUSA 1 TESTATA**  
**CHIUSURA PIANO MOD.TPA-7)**

**EN** Fryer threephase 45 lts - Bowl cm. 70x38x38h - 1  
basket cm. 65x33x17h. Sieve and lid for pan. Drip  
tray with sieve. Production: 40 kg/h (included 1 Head  
end filler strip mod.TPA-7) • **DE** Friteuse dreiphasig lt.  
45 - Becken cm. 70x38x38h - 1 Korb cm. 65x33x17h.  
Einlegesieb und Deckel für Becken. Fettauffangschale mit  
Sieb. Pommes frites: 40 kg/h (inbegriffen 1 Abschluss-  
Element mod.TPA-7) • **FR** Friteuse triphase lt. 45 - Cuve  
cm. 70x38x38h - 1 Panier cm. 65x33x17h. Filtre,  
couvercle pour cuve. Bac de récupération de l'huile  
avec filtre. Production de pommes frites: 40 kg/h (inclus  
1 Élément de jonction top mod.TPA-7) • **ES** Freidoras  
trifásico 45 lt. - Cuba cm. 70x38x38h - 1 cesta cm.  
65x33x17h. Filtro y tapa para cuba. Bandeja recoge  
aceite con filtro. Prod. patatas: 40 Kg/h (incluida 1  
Chapa de cierre para top mod.TPA-7)

**cm. 80x 70,5x 90h**



⚡ 40 kW **3.709,00**  
400V~3N 96 / 0,71  
50/60 Hz



Le immagini presentate non sono vincolanti. La ditta si riserva di  
apportare modifiche senza preavviso. • The pictures are purely re-  
presentative. The manufacturer reserves the right to modify the  
technical data and models without previous notice. • Les images

LO

présentées ne nous engagent pas. La Société se réserve le droit d'apporter tout  
modifi cation sans préavis. • Die dargestellten Abbildungen sind nicht verbindlich.  
Technische Änderungen vorbehalten. • Las imágenes presentadas no son vinculantes.  
El Fabricante se reserva el derecho de modifi car sus productos sin previo aviso.

01/20

163

70



# FRIGGITRICI A GAS

MOD. \_\_\_\_\_  
COD. \_\_\_\_\_

DESCRIZIONE/DESCRIPTION/BEZEICHNUNG/DESCRIPTION/DESCRIPCIÓN  
DIMENSIONI/DIMENSIONS/ABMESSUNGEN/DIMENSIONS/DIMENSIONES

POTENZA/POWER/LEISTUNG/PUISSANCE/POTENCIA  
VOLTAGGIO/VOLTAGE/SPANNUNG/VOLTAGE/VOLTAJE

⚡ kW  
kcal/h

PREZZO/PRICE €  
PREIS/PRIX/PRECIO €  
KG / M<sup>3</sup>

**F2/8-74G**  
08260452

**FRIGGITRICE GAS LT. 8+8 - 2 VASCHE CM. 15X35X36H 2 CESTI CM. 12X30X15H. FILTRO E COPERCHIO VASCA. 2 BACINELLE RACCOGLIOLIO CON FILTRO. PROD. PATATE: 12 KG/H (INCLUSA 1 TESTATA CHIUSURA PIANO MOD.TPA-7)**

**EN** Gas Fryer 8+8 lts - 2 pans cm. 15x35x36h 2 baskets cm. 12x30x15h. Sieve and lid for pan. 2 drip trays with sieves. Production: 12 kg/h (included 1 Head end filler strip mod.TPA-7) • **DE** Gas-Friteuse lt. 8+8 - 2 Becken cm. 15x35x36h 2 Körbe cm. 12x30x15h. Einlegesieb und Deckel für Becken. 2 Fettauffangschalen mit Sieb. Pommes frites: 12 kg/h (inbegriffen 1 Abschluss-Element mod.TPA-7) • **FR** Friteuse à gaz lt. 8+8 - 2 cuves cm. 15x35x36h 2 paniers cm. 12x30x15h. Filtre, couvercle pour cuve. 2 bacs de récupération de l'huile avec filtre. Production de pommes frites: 12 kg/h (inclus 1 Élément de jonction top mod.TPA-7) • **ES** Freidoras a gas 8+8 lt. - 2 cubas cm. 15x35x36h 2 cestas cm. 12x30x15h. Filtro y tapa para cuba. 2 bandejas recoge aceite con filtro. Prod. patatas: 12 Kg/h (incluida 1 Chapa de cierre para top mod.TPA-7)

**cm. 40x 70,5x 90h**



⚡ 10 kW  
8.600 kcal/h

**3.204,00**  
59 / 0,37

**F13-74G**  
08260450

**FRIGGITRICE GAS LT. 13 VASCA CM. 24X35X38H - 1 CESTO CM. 21X30X12H. FILTRO E COPERCHIO VASCA. BACINELLA RACCOGLIOLIO CON FILTRO. PROD. PATATE: 10 KG/H (INCLUSE ENTRAMBE LE TESTATE CHIUSURA PIANO)**

**EN** Gas Fryer 13 lts - Bowl cm. 24x35x38h - 1 basket cm. 21x30x12h. Sieve and lid for pan. Drip tray with sieve. Production: 10 kg/h (included both Heads end filler strip) • **DE** Gas-Friteuse lt. 13 - Becken cm. 24x35x38h - 1 Korb cm. 21x30x12h. Einlegesieb und Deckel für Becken. Fettauffangschale mit Sieb. Pommes frites: 10 kg/h (inbegriffen alle 2 Abschluss-Element) • **FR** Friteuse a gaz lt. 13 - Cuve cm. 24x35x38h - 1 Panier cm. 21x30x12h. Filtre, couvercle pour cuve. Bac de récupération de l'huile avec filtre. Production de pommes frites: 10 kg/h (inclus tous 2 Élément de jonction top) • **ES** Freidoras a gas 13 lt. - Cuba cm. 24x35x38h - 1 cesta cm. 21x30x12h. Filtro y tapa para cuba. Bandeja recoge aceite con filtro. Prod. patatas: 10 Kg/h (incluidas todas las 2 Chapa de cierre para top)

**cm. 40x 70,5x 90h**



⚡ 9,3 kW  
8.000 kcal/h

**2.032,00**  
61 / 0,40

**F18-74G**  
08260451

**FRIGGITRICE GAS LT. 18 VASCA CM. 33X38X38H. - 1 CESTO CM. 30X33X12H. FILTRO E COPERCHIO VASCA. BACINELLA RACCOGLIOLIO CON FILTRO. PROD. PATATE: 15 KG/H (INCLUSE ENTRAMBE LE TESTATE CHIUSURA PIANO)**

**EN** Gas Fryer 18 lts - Bowl cm. 33x38x38h - 1 basket cm. 30x33x12h. Sieve and lid for pan. Drip tray with sieve. Production: 15 kg/h (included both Heads end filler strip) • **DE** Gas-Friteuse lt. 18 - Becken cm. 33x38x38h - 1 Korb cm. 30x33x12h. Einlegesieb und Deckel für Becken. Fettauffangschale mit Sieb. Pommes frites: 15 kg/h (inbegriffen alle 2 Abschluss-Element) • **FR** Friteuse a gaz lt. 18 - Cuve cm. 33x38x38h 1 Panier cm. 30x33x12h. Filtre, couvercle pour cuve. - Bac de récupération de l'huile avec filtre. Production de pommes frites: 15 kg/h (inclus tous 2 Élément de jonction top) • **ES** Freidoras a gas 18 lt. - Cuba cm. 33x38x38h - 1 cesta cm. 30x33x12h. Filtro y tapa para cuba. Bandeja recoge aceite con filtro. Prod. patatas: 15 Kg/h (incluidas todas las 2 Chapa de cierre para top)

**cm. 40x 70,5x 90h**

⚡ 13,5 kW  
11.610 kcal/h

**2.264,00**  
66 / 0,40

# FRIGGITRICI A GAS

MOD. \_\_\_\_\_  
COD. \_\_\_\_\_

DESCRIZIONE/DESCRIPTION/BEZEICHNUNG/DESCRIPTION/DESCRIPCIÓN  
DIMENSIONI/DIMENSIONS/ABMESSUNGEN/DIMENSIONS/DIMENSIONES

POTENZA/POWER/LEISTUNG/PUISSANCE/POTENCIA  
VOLTAGGIO/VOLTAGE/SPANNUNG/VOLTAGE/VOLTAJE

⚡ kW  
kcal/h

⚡ kw  
V~  
Hz

PREZZO/PRICE €  
PREIS/PRIX/PRECIO €  
KG / M<sup>3</sup>

**F2/13-78G**  
08260850

**FRIGGITRICE GAS LT. 13+13 - 2 VASCHE CM. 24X35X38H 2 CESTI CM. 21X30X12H. 2 FILTRI E COPERCHI VASCHE. 2 BACINELLE RACCOGLIOLIO CON FILTRO. PROD. PATATE: 20 KG/H (INCLUDE ENTRAMBE LE TESTATE CHIUSURA PIANO)**

**EN** Gas Fryer 13+13 lts - 2 pans cm. 24x35x38h 2 baskets cm. 21x30x12h. 2 sieve and lids for pan. 2 drip trays with sieves. Production: 20 kg/h (included both Heads end filler strip) • **DE** Gas-Friteuse lt. 13+13 - 2 Becken cm. 24x35x38h 2 Körbe cm. 21x30x12h. Einlegesieb und Deckel für Becken. 2 Fettauffangschalen mit Sieb. Pommes frites: 20 kg/h (inbegriffen alle 2 Abschluss-Element) • **FR** Friteuse à gaz lt. 13+13 - 2 cuves cm. 24x35x38h 2 paniers cm. 21x30x12h. 2 filtres, couvercles pour cuve. 2 bacs de récupération de l'huile avec filtre. Production de pommes frites: 20 kg/h (inclus tous 2 Elément de jonction top) • **ES** Freidoras a gas 13+13 lt. - 2 cubas cm. 24x35x38h 2 cestas cm. 21x30x12h. 2 filtros y tapas para cubas. 2 bandejas recoge aceite con filtro. Prod. patatas: 20 Kg/h (incluidas todas las 2 Chapa de cierre para top)  
**cm. 80x 70,5x 90h**



⚡ 18,6 kW  
16.000 kcal/h

**3.604,00**  
102 / 0,78

**F2/18-78G**  
08260851

**FRIGGITRICE GAS LT. 18+18 - 2 VASCHE CM. 33X38X38H 2 CESTI CM. 30X33X12H. 2 FILTRI E COPERCHI VASCHE. 2 BACINELLE RACCOGLIOLIO CON FILTRO. PROD. PATATE: 30 KG/H (INCLUDE ENTRAMBE LE TESTATE CHIUSURA PIANO)**

**EN** Gas Fryer 18+18 lts - 2 pans cm. 33x38x38h 2 baskets cm. 30x33x12h. 2 sieve and lids for pan. 2 drip trays with sieves. Production: 30 kg/h (included both Heads end filler strip) • **DE** Gas-Friteuse lt. 18+18 - 2 Becken cm. 33x38x38h 2 Körbe cm. 30x33x12h. Einlegesieb und Deckel für Becken. 2 Fettauffangschalen mit Sieb. Pommes frites: 30 kg/h (inbegriffen alle 2 Abschluss-Element) • **FR** Friteuse à gaz lt. 18+18 - 2 cuves cm. 33x38x38h 2 paniers cm. 30x33x12h. 2 filtres, couvercles pour cuve. 2 bacs de récupération de l'huile avec filtre. Production de pommes frites: 30 kg/h (inclus tous 2 Elément de jonction top) • **ES** Freidoras a gas 18+18 lt. - 2 cubas cm. 33x38x38h 2 cestas cm. 30x33x12h. 2 filtros y tapas para cuba. 2 bandejas recoge aceite con filtro. Prod. patatas: 30 Kg/h (incluidas todas las 2 Chapa de cierre para top)  
**cm. 80x 70,5x 90h**

⚡ 27 kW  
23.220 kcal/h

**3.967,00**  
111 / 0,78

**F45-78G**  
08260855

**FRIGGITRICE GAS LT. 45 VASCA CM. 70X38X38H. - 1 CESTO CM. 65X33X17H. FILTRO E COPERCHIO VASCA. BACINELLA RACCOGLIOLIO CON FILTRO. PROD. PATATE: 40 KG/H (INCLUDE ENTRAMBE LE TESTATE CHIUSURA PIANO)**

**EN** Gas Fryer 45 lts - Bowl cm. 70x38x38h - 1 basket cm. 65x33x17h. Sieve and lid for pan. Drip tray with sieve. Production: 40 kg/h (included both Heads end filler strip) • **DE** Gas-Friteuse lt. 45 - Becken cm. 70x38x38h - 1 Korb cm. 65x33x17h. Einlegesieb und Deckel für Becken. Fettauffangschale mit Sieb. Pommes frites: 40 kg/h (inbegriffen alle 2 Abschluss-Element) • **FR** Friteuse a gaz lt. 45 - Cuve cm. 70x38x38h - 1 Panier cm. 65x33x17h. Filtre, couvercle pour cuve. Bac de récupération de l'huile avec filtre. Production de pommes frites: 40 kg/h (inclus tous 2 Elément de jonction top) • **ES** Freidoras a gas 45 lt. - Cuba cm. 70x38x38h - 1 cesta cm. 65x33x17h. Filtro y tapa para cuba. Bandeja recoge aceite con filtro. Prod. patatas: 40 Kg/h (incluidas todas las 2 Chapa de cierre para top)  
**cm. 80x 70,5x 90h**



⚡ 44 kW  
37.840 kcal/h

**4.487,00**  
110 / 1,07

⚡ 0,005 kW  
230V~  
50 Hz



Le immagini presentate non sono vincolanti. La ditta si riserva di apportare modifiche senza preavviso. • The pictures are purely representative. The manufacturer reserves the right to modify the technical data and models without previous notice. • Les images

LO

présentées ne nous engagent pas. La Société se réserve le droit d'apporter tout modification sans préavis. • Die dargestellten Abbildungen sind nicht verbindlich. Technische Änderungen vorbehalten. • Las imágenes presentadas no son vinculantes. El Fabricante se reserva el derecho de modificar sus productos sin previo aviso.

01/20

165

70

MOD. \_\_\_\_\_  
COD. \_\_\_\_\_

DESCRIZIONE/DESCRIPTION/BEZEICHNUNG/DESCRIPTION/DESCRIPCIÓN  
DIMENSIONI/DIMENSIONS/ABMESSUNGEN/DIMENSIONS/DIMENSIONES

POTENZA/POWER/LEISTUNG/PUISSANCE/POTENCIA  
VOLTAGGIO/VOLTAGE/SPANNUNG/VOLTAGE/VOLTAJE

⚡ kcal/h  
⚡ kW  
V~  
Hz

PREZZO/PRICE €  
PREIS/PRIX/PRECIO €  
KG / M<sup>3</sup>

**F18-74ETD**  
0815A430

**FRIGGITRICE ELETTRICA ELETTRONICA CON TOUCHSCREEN 7". CONSERVAZIONE A 110 °C O PRELAVORO A 160 °C CON O SENZA MELTING. POSSIBILITÀ DI INSERIRE IN MEMORIA FINO A 100 PROGRAMMI. SENSORE PRESENZA E LIVELLO MASSIMO OLIO. VASCA 18 LITRI CM.31X34X33H - 2 CESTI CM.13,5X29X15H - FILTRO E COPERCHIO VASCA. BACINELLA RACCOLTA OLIO CON SUPPORTO SU RUOTE E FILTRO 5 MICRON (100 INCLUSI). PRODUZIONE PATATE: 27 KG/H (INCLUSA 1 TESTATA CHIUSURA PIANO MOD.TPA-7)**

**EN** Electric electronic Fryer with a 7" TouchScreen. Conservation at 110 °C and preworking at 160 °C with or without Melting. Possibility to store in the memory up to 100 programs. Oil presence sensor and maximum level sensor. Bowl 18 lts cm.31x34x33h - 2 baskets cm.13,5x29x15h. Sieve and lid for pan. Oil collection basin with support on wheels with sieve 5 microns (pcs.100 included). Production: 27 kg/h (included 1 Head end filler strip mod.TPA-7) • **DE** ELEKTRONISCHE ELEKTRISCHE FRITEUSE mit TouchScreen 7". Aufbewahrung bei 110 °C oder Vorbearbeitung bei 160 °C mit oder ohne Melting. Es können bis zu 100 Programme gespeichert werden. Anwesenheits- sowie maximaler Ölstandsensor. Becken 18 lt. cm.31x34x33h - 2 Körbe cm.13,5x29x15h. Einlegesieb und Deckel für Becken. Ölauffangbecken mit Halterung auf Rädern und 5-Mikron-Filter (Stk.100 inbegriffen). Pommes frites: 27 kg/h (inbegriffen 1 Abschluss-Element mod.TPA-7) • **FR** FRITEUSE ÉLECTRIQUE ÉLECTRONIQUE à Écran tactile 7". Conservation à 110 °C ou Pré-traitement à 160 °C avec ou sans Melting. Possibilité d'enregistrer jusqu'à 100 programmes en mémoire. Capteur de présence et de niveau maximal huile. Cuve 18 lt. cm.31x34x33h - 2 Paniers cm.13,5x29x15h. Filtre, couvercle pour cuve. Bassine de collecte de l'huile avec support sur roues et filtre 5 microns (pcs.100 inclus). Production de pommes frites: 27 kg/h (inclus 1 Élément de jonction top mod. TPA-7) • **ES** FREIDORA ELÉCTRICA ELECTRÓNICA con pantalla táctil de 7". Conservación a 110 °C o trabajo previo a 160 °C con o sin fusión. Se pueden almacenar hasta 100 programas en la memoria. Sensor de presencia y nivel máximo de aceite. Cuba de 18 litros cm. 31x34x33h - 2 cestas cm.13,5x29x15h. Filtro y tapa para cuba. Cubeta de recogida de aceite con soporte sobre ruedas y filtro de 5 micrones (pz.100 incluida). Prod. patatas: 27 Kg/h (incluida 1 Chapa de cierre para top mod.TPA-7)

**cm. 40x 70,5x 90h**



⚡ 15,95 kW  
400V~3N  
50/60 Hz

**4.998,00**  
63 / 0,37

MOD. \_\_\_\_\_  
COD. \_\_\_\_\_

DESCRIZIONE/DESCRIPTION/BEZEICHNUNG/DESCRIPTION/DESCRIPCIÓN  
DIMENSIONI/DIMENSIONS/ABMESSUNGEN/DIMENSIONS/DIMENSIONES

POTENZA/POWER/LEISTUNG/PUISSANCE/POTENCIA  
VOLTAGGIO/VOLTAGE/SPANNUNG/VOLTAGE/VOLTAJE

⚡ kW  
kcal/h

⚡ kw  
V~  
Hz

PREZZO/PRICE €  
PREIS/PRIX/PRECIO €  
KG / M<sup>3</sup>

**F18-74ETDP 0815A431 FRIGGITRICE ELETTRICA ELETTRONICA CON TOUCHSCREEN 7". CONSERVAZIONE A 110 °C O PRELAVORO A 160 °C CON O SENZA MELTING. POSSIBILITÀ DI INSERIRE IN MEMORIA FINO A 100 PROGRAMMI. SENSORE PRESENZA E LIVELLO MASSIMO OLIO. POMPA FILTRAGGIO OLIO A CALDO MAX 180°C, PULIZIA VASCA, SVUOTAMENTO VASCA. VASCA 18 LITRI CM.31X34X33H - 2 CESTI CM.13,5X29X15H - FILTRO E COPERCHIO VASCA. BACINELLA RACCOLTA OLIO CON SUPPORTO SU RUOTE E FILTRO 5 MICRON (PZ.100 INCLUSI). PRODUZIONE PATATE: 27 KG/H (INCLUSA 1 TESTATA CHIUSURA PIANO MOD.TPA-7)**

**EN** Electric electronic Fryer with a 7" TouchScreen. Conservation at 110 °C and preworking at 160 °C with or without Melting. Possibility to store in the memory up to 100 programs. Oil presence sensor and maximum level sensor. Pump for filter the hot oil max 180°C, Tank cleaning, Tank emptying. Bowl 18 lts cm.31x34x33h - 2 baskets cm.13,5x29x15h. Sieve and lid for pan. Oil collection basin with support on wheels with sieve 5 microns (pcs.100 included). Production: 27 kg/h (included 1 Head end filler strip mod.TPA-7) • **DE** ELEKTRONISCHE ELEKTRISCHE FRITEUSE mit TouchScreen 7". Aufbewahrung bei 110 °C oder Vorbearbeitung bei 160 °C mit oder ohne Melting. Es können bis zu 100 Programme gespeichert werden. Anwesenheits- sowie maximaler Ölstandsensoren. Heißölfilterpumpe max 180°C, Tankreinigung, Tankentleerung. Becken 18 lt. cm.31x34x33h - 2 Körbe cm.13,5x29x15h. Einlegesieb und Deckel für Becken. Ölaufangbecken mit Halterung auf Rädern und 5-Mikron-Filter (Stk.100 inbegriffen). Pommes frites: 27 kg/h (inbegriffen 1 Abschluss-Element mod.TPA-7) • **FR** FRITEUSE ÉLECTRIQUE ÉLECTRONIQUE à Écran tactile 7". Conservation à 110 °C ou Pré-traitement à 160 °C avec ou sans Melting. Possibilité d'enregistrer jusqu'à 100 programmes en mémoire. Capteur de présence et de niveau maximal huile. Pompe filtration huile à chaud max 180°C, nettoyage cuve, vidange cuve. Cuve 18 lt. cm.31x34x33h - 2 Paniers cm.13,5x29x15h. Filtre, couvercle pour cuve. Bassine de collecte de l'huile avec support sur roues et filtre 5 microns (pcs.100 inclus). Production de pommes frites: 27 kg/h (inclus 1 Élément de jonction top mod.TPA-7) • **ES** FREIDORA ELÉCTRICA ELECTRÓNICA con pantalla táctil de 7". Conservación a 110 °C o trabajo previo a 160 °C con o sin fusión. Se pueden almacenar hasta 100 programas en la memoria. Sensor de presencia y nivel máximo de aceite. Bomba de filtrado de aceite caliente, máximo 180 °C, limpieza del tanque, vaciado del tanque. Cuba de 18 litros cm. 31x34x33h - 2 cestas cm.13,5x29x15h. Filtro y tapa para cuba. Cubeta de recogida de aceite con soporte sobre ruedas y filtro de 5 micrones (pz.100 incluida). Prod. patatas: 27 Kg/h (incluida 1 Chapa de cierre para top mod.TPA-7)

**cm. 40x 70,5x 90h**



⚡ 16,2 kW  
400V~3N  
50/60 Hz

**7.699,00**  
73 / 0,37

MOD. \_\_\_\_\_  
COD. \_\_\_\_\_

DESCRIZIONE/DESCRIPTION/BEZEICHNUNG/DESCRIPTION/DESCRIPCIÓN  
DIMENSIONI/DIMENSIONS/ABMESSUNGEN/DIMENSIONS/DIMENSIONES

POTENZA/POWER/LEISTUNG/PUISSANCE/POTENCIA  
VOLTAGGIO/VOLTAGE/SPANNUNG/VOLTAGE/VOLTAJE

⚡ kW  
kcal/h  
⚡ kW  
V~  
Hz

PREZZO/PRICE €  
PREIS/PRIX/PRECIO €  
KG / M<sup>3</sup>

**F18-74ETDPS FRIGGITRICE ELETTRICA ELETTRONICA CON TOUCHSCREEN 7". CONSERVAZIONE A 110 °C O PRELAVORO A 160 °C CON O SENZA MELTING. POSSIBILITÀ DI INSERIRE IN MEMORIA FINO A 100 PROGRAMMI. SENSORE PRESENZA E LIVELLO MASSIMO OLIO. POMPA FILTRAGGIO OLIO A CALDO MAX 180°C, PULIZIA VASCA, SVUOTAMENTO VASCA. 2 SOLLEVATORI CESTI INTEGRATI. VASCA 18 LITRI CM.31X34X33H - 2 CESTI CM.13,5X29X15H - FILTRO E COPERCHIO VASCA. BACINELLA RACCOLTA OLIO CON SUPPORTO SU RUOTE E FILTRO 5 MICRON (PZ.100 INCLUSI). PRODUZIONE PATATE: 27 KG/H (INCLUSA 1 TESTATA CHIUSURA PIANO MOD.TPA-7)**

**EN** Electric electronic Fryer with a 7" TouchScreen. Conservation at 110 °C and preworking at 160 °C with or without Melting. Possibility to store in the memory up to 100 programs. Oil presence sensor and maximum level sensor. Pump for filter the hot oil max 180°C, Tank cleaning, Tank emptying. 2 Lifter for baskets integrated. Bowl 18 lts cm.31x34x33h - 2 baskets cm.13,5x29x15h. Sieve and lid for pan. Oil collection basin with support on wheels with sieve 5 microns (pcs.100 included). Production: 27 kg/h (included 1 Head end filler strip mod.TPA-7) • **DE** ELEKTRONISCHE ELEKTRISCHE FRITEUSE mit TouchScreen 7". Aufbewahrung bei 110 °C oder Vorbearbeitung bei 160 °C mit oder ohne Melting. Es können bis zu 100 Programme gespeichert werden. Anwesenheits- sowie maximaler Ölstandsensor. Heißölfilterpumpe max 180°C, Tankreinigung, Tankentleerung. Integrierte 2 Korbheber. Becken 18 lt. cm.31x34x33h - 2 Körbe cm.13,5x29x15h. Einlegesieb und Deckel für Becken. Ölauffangbecken mit Halterung auf Rädern und 5-Mikron-Filter (Stk.100 inbegriffen). Pommes frites: 27 kg/h (inbegriffen 1 Abschluss-Element mod.TPA-7) • **FR** FRITEUSE ÉLECTRIQUE ÉLECTRONIQUE à Écran tactile 7". Conservation à 110 °C ou Pré-traitement à 160 °C avec ou sans Melting. Possibilité d'enregistrer jusqu'à 100 programmes en mémoire. Capteur de présence et de niveau maximal huile. Pompe filtration huile à chaud max 180°C, nettoyage cuve, vidange cuve. 2 Élévateurs paniers intégrés. Cuve 18 lt. cm.31x34x33h - 2 Paniers cm.13,5x29x15h. Filtre, couvercle pour cuve. Bassine de collecte de l'huile avec support sur roues et filtre 5 microns (pcs.100 inclus). Production de pommes frites: 27 kg/h (inclus 1 Élément de jonction top mod.TPA-7) • **ES** FREIDORA ELÉCTRICA ELECTRÓNICA con pantalla táctil de 7". Conservación a 110 °C o trabajo previo a 160 °C con o sin fusión. Se pueden almacenar hasta 100 programas en la memoria. Sensor de presencia y nivel máximo de aceite. Bomba de filtrado de aceite caliente, máximo 180 °C, limpieza del tanque, vaciado del tanque. 2 Elevadores de cesta integrados. Cuba de 18 litros cm. 31x34x33h - 2 cestas cm.13,5x29x15h. Filtro y tapa para cuba. Cubeta de recogida de aceite con soporte sobre ruedas y filtro de 5 micrones (pz.100 incluida). Prod. patatas: 27 Kg/h (incluida 1 Chapa de cierre para top mod.TPA-7)  
**cm. 40x 70,5x 90h**



⚡ 16,55 kW  
400V~3N  
50/60 Hz

**9.590,00**  
83 / 0,37



MOD. \_\_\_\_\_  
COD. \_\_\_\_\_

DESCRIZIONE/DESCRIPTION/BEZEICHNUNG/DESCRIPTION/DESCRIPCIÓN  
DIMENSIONI/DIMENSIONS/ABMESSUNGEN/DIMENSIONS/DIMENSIONES

POTENZA/POWER/LEISTUNG/PUISSANCE/POTENCIA  
VOLTAGGIO/VOLTAGE/SPANNUNG/VOLTAGE/VOLTAJE

⚡ kW kcal/h  
⚡ kw V~ Hz

PREZZO/PRICE €  
PREIS/PRIX/PRECIO €  
KG / M<sup>3</sup>

**F2/18-78ETD FRIGGITRICE ELETTRICA ELETTRONICA CON TOUCHSCREEN 7". CONSERVAZIONE A 110 °C O PRELAVORO A 160 °C CON O SENZA MELTING. POSSIBILITÀ DI INSERIRE IN MEMORIA FINO A 100 PROGRAMMI. SENSORE PRESENZA E LIVELLO MASSIMO OLIO. 2 VASCHE 18 LITRI CM.31X34X33H - 4 CESTI CM.13,5X29X15H - FILTRI E COPERCHI VASCHE. 2 BACINELLE RACCOLTA OLIO CON SUPPORTO SU RUOTE E FILTRO 5 MICRON (PZ.100 INCLUSI). PRODUZIONE PATATE: 54 KG/H (INCLUSA 1 TESTATA CHIUSURA PIANO MOD.TPA-7)**

**EN** Electric electronic Fryer with a 7" TouchScreen. Conservation at 110 °C and preworking at 160 °C with or without Melting. Possibility to store in the memory up to 100 programs. Oil presence sensor and maximum level sensor. 2 bowls 18 lts cm.31x34x33h - 4 baskets cm.13,5x29x15h. 2 Sieve and lid for pan. 2 Oil collection basin with support on wheels with sieve 5 microns (pcs.100 included). Production: 54 kg/h (included 1 Head end filler strip mod.TPA-7)

• **DE** ELEKTRONISCHE ELEKTRISCHE FRITEUSE mit TouchScreen 7". Aufbewahrung bei 110 °C oder Vorbereitung bei 160 °C mit oder ohne Melting. Es können bis zu 100 Programme gespeichert werden.

Anwesenheits- sowie maximaler Ölstandsensor. 2 Becken 18 lt. cm.31x34x33h - 4 Körbe cm.13,5x29x15h. 2 Einlegesieb und Deckel für Becken. Ölauffangbecken mit Halterung auf Rädern und 5-Mikron-Filter (Stk.100 inbegriffen). Pommes frites: 54 kg/h (inbegriffen 1 Abschluss-Element mod.TPA-7) • **FR** FRITEUSE ÉLECTRIQUE ÉLECTRONIQUE à Écran tactile 7".

Conservation à 110 °C ou Pré-traitement à 160 °C avec ou sans Melting. Possibilité d'enregistrer jusqu'à 100 programmes en mémoire. Capteur de présence et de niveau maximal huile. 2 Cuves 18 lt. cm.31x34x33h - 4 Paniers cm.13,5x29x15h. 2 Filtre, couvercle pour cuve. 2 Bassine de collecte de l'huile avec support sur roues et filtre 5 microns (pcs.100 inclus). Production de pommes frites: 54 kg/h (inclus 1 Élément de jonction top mod.TPA-7) • **ES** FREIDORA ELÉCTRICA ELECTRÓNICA con pantalla táctil de 7".

Conservación a 110 °C o trabajo previo a 160 °C con o sin fusión. Se pueden almacenar hasta 100 programas en la memoria. Sensor de presencia y nivel máximo de aceite. 2 Cubas de 18 litros cm. 31x34x33h - 4 cestas cm.13,5x29x15h. 2 Filtros y tapas para cuba. 2 Cubetas de recogida de aceite con soporte sobre ruedas y filtro de 5 micrones (pz.100 incluida). Prod. patatas: 54 Kg/h (incluida 1 Chapa de cierre para top mod.TPA-7)

**cm. 80x 70,5x 90h**



⚡ 31,9 kW **9.056,00**  
400V~3N 109 / 0,71  
50/60 Hz

MOD. \_\_\_\_\_  
COD. \_\_\_\_\_

DESCRIZIONE/DESCRIPTION/BEZEICHNUNG/DESCRIPTION/DESCRIPCIÓN  
DIMENSIONI/DIMENSIONS/ABMESSUNGEN/DIMENSIONS/DIMENSIONES

POTENZA/POWER/LEISTUNG/PUISSANCE/POTENCIA  
VOLTAGGIO/VOLTAGE/SPANNUNG/VOLTAGE/VOLTAJE

⚡ kW  
kcal/h

⚡ kW  
V~  
Hz

PREZZO/PRICE €  
PREIS/PRIX/PRECIO €  
KG / M<sup>3</sup>

F2/18-78ETDP  
0815A831

**FRIGGITRICE ELETTRICA ELETTRONICA CON TOUCHSCREEN 7". CONSERVAZIONE A 110 °C O PRELAVORO A 160 °C CON O SENZA MELTING. POSSIBILITÀ DI INSERIRE IN MEMORIA FINO A 100 PROGRAMMI. SENSORE PRESENZA E LIVELLO MASSIMO OLIO. 2 POMPE FILTRAGGIO OLIO A CALDO MAX 180°C, PULIZIA VASCA, SVUOTAMENTO VASCA. 2 VASCHE 18 LITRI CM.31X34X33H - 4 CESTI CM.13,5X29X15H - FILTRI E COPERCHI VASCHE. 2 BACINELLE RACCOLTA OLIO CON SUPPORTO SU RUOTE E FILTRO 5 MICRON (PZ.100 INCLUSI). PRODUZIONE PATATE: 54 KG/H (INCLUSA 1 TESTATA CHIUSURA PIANO MOD.TPA-7)**

**EN** Electric electronic Fryer with a 7" TouchScreen. Conservation at 110 °C and preworking at 160 °C with or without Melting. Possibility to store in the memory up to 100 programs. Oil presence sensor and maximum level sensor. 2 Pump for filter the hot oil max 180°C, Tank cleaning, Tank emptying. 2 bowls 18 lts cm.31x34x33h - 4 baskets cm.13,5x29x15h. 2 Sieve and lid for pan. 2 Oil collection basin with support on wheels with sieve 5 microns (pcs.100 included). Production: 54 kg/h (included 1 Head end filler strip mod.TPA-7) • **DE** ELEKTRONISCHE ELEKTRISCHE FRITEUSE mit TouchScreen 7". Aufbewahrung bei 110 °C oder Vorbearbeitung bei 160 °C mit oder ohne Melting. Es können bis zu 100 Programme gespeichert werden. Anwesenheits- sowie maximaler Ölstandsensoren. 2 Heißölfilterpumpe max 180°C, Tankreinigung, Tankentleerung. 2 Becken 18 lt. cm.31x34x33h - 4 Körbe cm.13,5x29x15h. 2 Einlegesieb und Deckel für Becken. 2 Ölauffangbecken mit Halterung auf Rädern und 5-Mikron-Filter (Stk.100 inbegriffen). Pommes frites: 54 kg/h (inbegriffen 1 Abschluss-Element mod. TPA-7) • **FR** FRITEUSE ÉLECTRIQUE ÉLECTRONIQUE à Écran tactile 7". Conservation à 110 °C ou Pré-traitement à 160 °C avec ou sans Melting. Possibilité d'enregistrer jusqu'à 100 programmes en mémoire. Capteur de présence et de niveau maximal huile. 2 Pompe filtration huile à chaud max 180°C, nettoyage cuve, vidange cuve. 2 Cuves 18 lt. cm.31x34x33h - 4 Paniers cm.13,5x29x15h. 2 Filtre, couvercle pour cuve. 2 Bassine de collecte de l'huile avec support sur roues et filtre 5 microns (pcs.100 inclus). Production de pommes frites: 54 kg/h (inclus 1 Élément de jonction top mod. TPA-7) • **ES** FREIDORA ELÉCTRICA ELECTRÓNICA con pantalla táctil de 7". Conservación a 110 °C o trabajo previo a 160 °C con o sin fusión. Se pueden almacenar hasta 100 programas en la memoria. Sensor de presencia y nivel máximo de aceite. 2 Bomba de filtrado de aceite caliente, máximo 180 °C, limpieza del tanque, vaciado del tanque. 2 Cubas de 18 litros cm. 31x34x33h - 4 cestas cm.13,5x29x15h. 2 Filtros y tapas para cuba. 2 Cubetas de recogida de aceite con soporte sobre ruedas y filtro de 5 micrones (pz.100 incluida). Prod. patatas: 54 Kg/h (incluida 1 Chapa de cierre para top mod.TPA-7)  
**cm. 80x 70,5x 90h**



⚡ 32,4 kW **14.458,00**  
400V~3N 129 / 0,71  
50/60 Hz

# FRIGGITRICI ELETTRICHE DIGITALI

MOD. \_\_\_\_\_  
COD. \_\_\_\_\_

DESCRIZIONE/DESCRIPTION/BEZEICHNUNG/DESCRIPTION/DESCRIPCIÓN  
DIMENSIONI/DIMENSIONS/ABMESSUNGEN/DIMENSIONS/DIMENSIONES

POTENZA/POWER/LEISTUNG/PUISSANCE/POTENCIA  
VOLTAGGIO/VOLTAGE/SPANNUNG/VOLTAGE/VOLTAJE

⚡ kW \_\_\_\_\_ kcal/h \_\_\_\_\_  
V~ \_\_\_\_\_ Hz \_\_\_\_\_

PREZZO/PRICE € \_\_\_\_\_  
PREIS/PRIX/PRECIO € \_\_\_\_\_  
KG / M<sup>3</sup> \_\_\_\_\_

**F2/18-78ETDPS FRIGGITRICE ELETTRICA ELETTRONICA CON TOUCHSCREEN 7". CONSERVAZIONE A 110 °C O PRELAVORO A 160 °C CON O SENZA MELTING. POSSIBILITÀ DI INSERIRE IN MEMORIA FINO A 100 PROGRAMMI. SENSORE PRESENZA E LIVELLO MASSIMO OLIO. 2 POMPE FILTRAGGIO OLIO A CALDO MAX 180°C, PULIZIA VASCA, SVUOTAMENTO VASCA. 4 SOLLEVATORI CESTI INTEGRATI. 2 VASCHE 18 LITRI CM.31X34X33H - 4 CESTI CM.13,5X29X15H - FILTRI E COPERCHI VASCHE. 2 BACINELLE RACCOLTA OLIO CON SUPPORTO SU RUOTE E FILTRO 5 MICRON (PZ.100 INCLUSI). PRODUZIONE PATATE: 54 KG/H (INCLUSA 1 TESTATA CHIUSURA PIANO MOD.TPA-7)**

**EN** Electric electronic Fryer with a 7" TouchScreen. Conservation at 110 °C and preworking at 160 °C with or without Melting. Possibility to store in the memory up to 100 programs. Oil presence sensor and maximum level sensor. 2 Pump for filter the hot oil max 180°C, Tank cleaning, Tank emptying. 4 Lifter for baskets integrated. 2 bowls 18 lts cm.31x34x33h - 4 baskets cm.13,5x29x15h. 2 Sieve and lid for pan. 2 Oil collection basin with support on wheels with sieve 5 microns (pcs.100 included). Production: 54 kg/h (included 1 Head end filler strip mod.TPA-7)  
**• DE** ELEKTRONISCHE ELEKTRISCHE FRITEUSE mit TouchScreen 7". Aufbewahrung bei 110 °C oder Vorbearbeitung bei 160 °C mit oder ohne Melting. Es können bis zu 100 Programme gespeichert werden. Anwesenheits- sowie maximaler Ölstandsensoren. 2 Heißölfilterpumpe max 180°C, Tankreinigung, Tankentleerung. Integrierte 4 Korbheber. 2 Becken 18 lt. cm.31x34x33h - 4 Körbe cm.13,5x29x15h. 2 Einlegesieb und Deckel für Becken. 2 Ölauffangbecken mit Halterung auf Rädern und 5-Mikron-Filter (Stk.100 inbegriffen). Pommes frites: 54 kg/h (inbegriffen 1 Abschluss-Element mod.TPA-7)  
**• FR** FRITEUSE ÉLECTRIQUE ÉLECTRONIQUE à Écran tactile 7". Conservation à 110 °C ou Pré-traitement à 160 °C avec ou sans Melting. Possibilité d'enregistrer jusqu'à 100 programmes en mémoire. Capteur de présence et de niveau maximal huile. 2 Pompe filtration huile à chaud max 180°C, nettoyage cuve, vidange cuve. 4 Élévateurs paniers intégrés. 2 Cuve 18 lt. cm.31x34x33h - 4 Paniers cm.13,5x29x15h. 2 Filtre, couvercle pour cuve. 2 Bassine de collecte de l'huile avec support sur roues et filtre 5 microns (pcs.100 inclus). Production de pommes frites: 54 kg/h (inclus 1 Élément de jonction top mod. TPA-7)  
**• ES** FREIDORA ELÉCTRICA ELECTRÓNICA con pantalla táctil de 7". Conservación a 110 °C o trabajo previo a 160 °C con o sin fusión. Se pueden almacenar hasta 100 programas en la memoria. Sensor de presencia y nivel máximo de aceite. 2 Bomba de filtrado de aceite caliente, máximo 180 °C, limpieza del tanque, vaciado del tanque. 4 Elevadores de cesta integrados. 2 Cubas de 18 litros cm. 31x34x33h - 4 cestas cm.13,5x29x15h. 2 Filtros y tapas para cuba. 2 Cubetas de recogida de aceite con soporte sobre ruedas y filtro de 5 micrones (pz.100 incluida). Prod. patatas: 54 Kg/h (incluida 1 Chapa de cierre para top mod. TPA-7)  
**cm. 80x 70,5x 90h**



⚡ 33,1 kW \_\_\_\_\_ **18.240,00**  
400V~3N \_\_\_\_\_ 149 / 0,71  
50/60 Hz \_\_\_\_\_

**BR50-78ETF/I BRASIERA ELETTRICA 50 LT. RIB. MANUALE FONDO INOX CON COPERCHIO**

**EN** Electric 50 lts. manual tilt. brat pan Stainless steel bottom with lid • **DE** Elektrische Kippbratpfanne 50 Lt. Man. Kippung boden aus crnst. mit deckel • **FR** Sauteuse électrique 50 l. basc. manuel fond inox avec couvercle • **ES** Sartén eléctrica 50lt. abat. manual fondo de acero inox. con tapa  
**cm. 80x 70,5x 90h**



⚡ 10,5 kW \_\_\_\_\_ **4.756,00**  
400V~3N \_\_\_\_\_ 133 / 0,71  
50/60 Hz \_\_\_\_\_



Le immagini presentate non sono vincolanti. La ditta si riserva di apportare modifiche senza preavviso. • The pictures are purely representative. The manufacturer reserves the right to modify the technical data and models without previous notice. • Les images

LO

présentées ne nous engagent pas. La Société se réserve le droit d'apporter tout modification sans préavis. • Die dargestellten Abbildungen sind nicht verbindlich. Technische Änderungen vorbehalten. • Las imágenes presentadas no son vinculantes. El Fabricante se reserva el derecho de modificar sus productos sin previo aviso.

01/20

171

# BRASIERE RIBALTABILI ELETTRICHE

MOD. \_\_\_\_\_  
COD. \_\_\_\_\_

DESCRIZIONE/DESCRIPTION/BEZEICHNUNG/DESCRIPTION/DESCRIPCIÓN  
DIMENSIONI/DIMENSIONS/ABMESSUNGEN/DIMENSIONS/DIMENSIONES

POTENZA/POWER/LEISTUNG/PUISSANCE/POTENCIA  
VOLTAGGIO/VOLTAGE/SPANNUNG/VOLTAGE/VOLTAJE

⚡ kW \_\_\_\_\_  
kcal/h \_\_\_\_\_  
V~ \_\_\_\_\_  
Hz \_\_\_\_\_

PREZZO/PRICE € \_\_\_\_\_  
PREIS/PRIX/PRECIO € \_\_\_\_\_  
KG / M<sup>3</sup> \_\_\_\_\_

## BRM50-78EF/I BRASIERA ELETTRICA 50 LT. RIB. AUTOMATICO FONDO INOX CON COPERCHIO

08070836

**EN** Electric 50 lts. automatic tilt. brat pan - Stainless steel bottom with lid • **DE** Elektrische Bratpfanne 50 Lt. Autom. Kippung - boden aus crnst. mit deckel • **FR** Sauteuse électrique 50 l. basc. automatique - fond inox avec couvercle • **ES** Sartén eléctrica 50 lt. abat. automática - fondo de acero inox. con tapa  
**cm. 80x 70,5x 90h**



⚡ 10,6 kW \_\_\_\_\_ **5.973,00**  
400V~3N \_\_\_\_\_ 135 / 0,71  
50 Hz \_\_\_\_\_

## BR50-78GF/I BRASIERA GAS 50 LT. RIB. MANUALE FONDO INOX CON COPERCHIO

08240855

**EN** Gas 50 lts. manual tilt. brat pan - Stainless steel bottom with lid • **DE** Gas-Kippbratpfanne 50 Lt. Man. Kippung - boden aus crnst. mit deckel • **FR** Sauteuse à gaz 50 l. basc. manuel - fond inox avec couvercle • **ES** Sartén a gas 50lt. abat. manual - fondo de acero inox. con tapa  
**cm. 80x 70,5x 90h**



⚡ 14 kW \_\_\_\_\_ **5.178,00**  
12.040 kcal/h \_\_\_\_\_ 135 / 0,71

## BRM50-78GF/I BRASIERA GAS 50 LT. RIB. AUTOMATICO FONDO INOX CON COPERCHIO

08240856

**EN** Gas 50 lts. automatic tilt. brat pan - Stainless steel bottom with lid • **DE** Gas-Bratpfanne 50 Lt. Autom. Kippung - boden aus crnst. mit deckel • **FR** Sauteuse à gaz 50 l. basc. automatique - fond inox avec couvercle • **ES** Sartén a gas 50lt. abat. automática - fondo de acero inox. con tapa  
**cm. 80x 70,5x 90h**



⚡ 14 kW \_\_\_\_\_ **6.201,00**  
12.040 kcal/h \_\_\_\_\_ 139 / 0,71

⚡ 0,1 kW \_\_\_\_\_  
230V~ \_\_\_\_\_  
50 Hz \_\_\_\_\_

## BRF-74ET BRASIERA FISSA MULTIFUNZIONALE ELETTRICA VASCA CM. 30X51X10H (INCLUSA 1 TESTATA CHIUSURA PIANO MOD.TPA-7)

08070433

**EN** Electric multi-function fixed braising pan - Bowl cm. 30x51x10h (included 1 Head end filler strip mod. TPA-7) • **DE** Elektrische Multifunktionsbratpfanne Fest Becken cm. 30x51x10h (inbegriffen 1 Abschluss-Element mod.TPA-7) • **FR** Sauteuse fixe multifonction électrique - Cuve cm. 30x51x10h (inclus 1 Élément de jonction top mod.TPA-7) • **ES** Sarten fija multifunción eléctrica - Cuba cm. 30x51x10h (incluida 1 Chapa de cierre para top mod.TPA-7)  
**cm. 40x 70,5x 90h**



⚡ 4 kW \_\_\_\_\_ **3.084,00**  
400V~2N \_\_\_\_\_ 79 / 0,37  
230V~3 \_\_\_\_\_  
50/60 Hz \_\_\_\_\_

## BRF-78ET BRASIERA FISSA MULTIFUNZIONALE ELETTRICA VASCA CM. 70X51X10H (INCLUSA 1 TESTATA CHIUSURA PIANO MOD.TPA-7)

08070833

**EN** Electric multi-function fixed braising pan - Bowl cm. 70x51x10h (included 1 Head end filler strip mod. TPA-7) • **DE** Elektrische Multifunktionsbratpfanne Fest Becken cm. 70x51x10h (inbegriffen 1 Abschluss-Element mod.TPA-7) • **FR** Sauteuse fixe multifonction électrique - Cuve cm. 70x51x10h (inclus 1 Élément de jonction top mod.TPA-7) • **ES** Sarten fija multifunción eléctrica - Cuba cm. 70x51x10h (incluida 1 Chapa de cierre para top mod.TPA-7)  
**cm. 80x 70,5x 90h**



⚡ 8 kW \_\_\_\_\_ **4.665,00**  
400V~3N \_\_\_\_\_ 126 / 0,71  
50/60 Hz \_\_\_\_\_

# BRASIERE FISSE MULTIFUNZIONE A GAS

MOD. \_\_\_\_\_  
COD. \_\_\_\_\_

DESCRIZIONE/DESCRIPTION/BEZEICHNUNG/DESCRIPTION/DESCRIPCIÓN  
DIMENSIONI/DIMENSIONS/ABMESSUNGEN/DIMENSIONS/DIMENSIONES

POTENZA/POWER/LEISTUNG/PUISSANCE/POTENCIA  
VOLTAGGIO/VOLTAGE/SPANNUNG/VOLTAGE/VOLTAJE

⚡ kW kcal/h  
⚡ kW V~ Hz

PREZZO/PRICE €  
PREIS/PRIX/PRECIO €  
KG / M<sup>3</sup>

**BRF-74G**  
08240453

**BRASIERA FISSA MULTIFUNZIONALE GAS  
VASCA 30X51X10H (INCLUSA 1 TESTATA  
CHIUSURA PIANO MOD.TPA-7)**

**EN** Gas multi-function fixed braising pan Bowl 30x51x10h (included 1 Head end filler strip mod. TPA-7) • **DE** Gas-Multifunktionsbratpfanne Fest Becken 30x51x10h (inbegriffen 1 Abschluss-Element mod. TPA-7) • **FR** Sauteuse fixe multifonction à gaz - Cuve 30x51x10h (inclus 1 Élément de jonction top mod. TPA-7) • **ES** Sartén fija multifunción a gas - Cuba 30x51x10h (incluida 1 Chapa de cierre para top mod. TPA-7)  
**cm. 40x 70,5x 90h**



⚡ 6,95 kW 3.297,00  
5.970 kcal/h 79 / 0,37

**BRF-78G**  
08240853

**BRASIERA FISSA MULTIFUNZIONALE GAS  
VASCA 70X51X10H (INCLUSA 1 TESTATA  
CHIUSURA PIANO MOD.TPA-7)**

**EN** Gas multi-function fixed braising pan Bowl 70x51x10h (included 1 Head end filler strip mod. TPA-7) • **DE** Gas-Multifunktionsbratpfanne Fest Becken 70x51x10h (inbegriffen 1 Abschluss-Element mod. TPA-7) • **FR** Sauteuse fixe multifonction à gaz - Cuve 70x51x10h (inclus 1 Élément de jonction top mod. TPA-7) • **ES** Sartén fija multifunción a gas - Cuba 70x51x10h (incluida 1 Chapa de cierre para top mod. TPA-7)  
**cm. 80x 70,5x 90h**



⚡ 13,9 kW 5.075,00  
11.940 kcal/h 129 / 0,71

**PL-72**  
08010200

**PIANO LAVORO SU MOBILE (INCLUSA 1  
TESTATA CHIUSURA PIANO MOD.TPA-7)**

**EN** Worktop on cabinet (included 1 Head end filler strip mod.TPA-7) • **DE** Arbeitsplatte mit Unterbau (inbegriffen 1 Abschluss-Element mod.TPA-7) • **FR** Plan de travail sur armoire (inclus 1 Élément de jonction top mod.TPA-7) • **ES** Sobre de trabajo sobre mueble (incluida 1 Chapa de cierre para top mod.TPA-7)  
**cm. 20x 70,5x 90h**



575,00  
30 / 0,37

**PLS-73**  
08010301

**PIANO LAVORO SU MOBILE A GIORNO  
(INCLUSA 1 TESTATA CHIUSURA PIANO MOD.  
TPA-7)**

**EN** Worktop on open cabinet (included 1 Head end filler strip mod.TPA-7) • **DE** Arbeitsplatte mit offenem Unterbau (inbegriffen 1 Abschluss-Element mod.TPA-7) • **FR** Plan de travail sur armoire ouvert (inclus 1 Élément de jonction top mod.TPA-7) • **ES** Sobre de trabajo sobre mueble abierto (incluida 1 Chapa de cierre para top mod.TPA-7)  
**cm. 30x 70,5x 90h**



694,00  
35 / 0,37

**PLS-74**  
08010401

**cm. 40x 70,5x 90h**



715,00  
40 / 0,37



Le immagini presentate non sono vincolanti. La ditta si riserva di apportare modifiche senza preavviso. • The pictures are purely representative. The manufacturer reserves the right to modify the technical data and models without previous notice. • Les images

LO

présentées ne nous engagent pas. La Société se réserve le droit d'apporter tout modification sans préavis. • Die dargestellten Abbildungen sind nicht verbindlich. Technische Änderungen vorbehalten. • Las imágenes presentadas no son vinculantes. El Fabricante se reserva el derecho de modificar sus productos sin previo aviso.

01/20

173



MOD. \_\_\_\_\_  
COD. \_\_\_\_\_

DESCRIZIONE/DESCRIPTION/BEZEICHNUNG/DESCRIPTION/DESCRIPCIÓN  
DIMENSIONI/DIMENSIONS/ABMESSUNGEN/DIMENSIONS/DIMENSIONES

POTENZA/POWER/LEISTUNG/PUISSANCE/POTENCIA  
VOLTAGGIO/VOLTAGE/SPANNUNG/VOLTAGE/VOLTAJE

⚡ kW kcal/h  
⚡ kW V~ Hz

PREZZO/PRICE €  
PREIS/PRIX/PRECIO €  
KG / M<sup>3</sup>

**PLS-76** cm. 60x 70,5x 90h  
08010601



**1.080,00**  
47 / 0,54

**PLS-78** cm. 80x 70,5x 90h  
08010801



**1.208,00**  
55 / 0,71

**PL-73** **PIANO LAVORO SU MOBILE A GIORNO**  
08010300 **CASSETTO - 1 BACINELLA INOX CM**  
**19X50X15H (INCLUSA 1 TESTATA CHIUSURA**  
**PIANO MOD.TPA-7)**

**EN** Worktop on open cabinet Drawer - 1 inox container cm 19x50x15h (included 1 Head end filler strip mod. TPA-7) • **DE** Arbeitsplatte mit offenem Unterbau Schublade - 1 Chromnickelstahlbehälter cm 19x50x15h (inbegriffen 1 Abschluss-Element mod.TPA-7) • **FR** Plan de travail sur armoire ouvert Tiroir - Bac en inox cm 19x50x15h (inclus 1 Élément de jonction top mod.TPA-7) • **ES** Sobre de trabajo sobre mueble abierto Cajón - 1 contenedor cm 19x50x15h de acero inox (incluida 1 Chapa de cierre para top mod.TPA-7)

cm. 30x 70,5x 90h



**942,00**  
40 / 0,37

**PL-74** **PIANO LAVORO SU MOBILE A GIORNO**  
08010400 **CASSETTO CON 1 BACINELLA GN 1/1 15H**  
**PLASTICA (INCLUSA 1 TESTATA CHIUSURA**  
**PIANO MOD.TPA-7)**

**EN** Worktop on open cabinet Drawer with 1 plastic container GN 1/1 15h (included 1 Head end filler strip mod.TPA-7) • **DE** Arbeitsplatte mit offenem Unterbau Schublade mit 1 GN 1/1 15h Kunststoffbehälter (inbegriffen 1 Abschluss-Element mod.TPA-7) • **FR** Plan de travail sur armoire ouvert Tiroir avec bac en plastique GN 1/1 15h. (inclus 1 Élément de jonction top mod. TPA-7) • **ES** Sobre de trabajo sobre mueble abierto Cajón con 1 contenedor GN 1/1 15h plástico (incluida 1 Chapa de cierre para top mod.TPA-7)

cm. 40x 70,5x 90h



**908,00**  
45 / 0,37

**PL-76** **PIANO LAVORO SU MOBILE A GIORNO**  
08010600 **CASSETTO - 1 BACINELLA INOX CM**  
**49X50X15H (INCLUSA 1 TESTATA CHIUSURA**  
**PIANO MOD.TPA-7)**

**EN** Worktop on open cabinet Drawer - 1 inox container cm 49x50x15h (included 1 Head end filler strip mod. TPA-7) • **DE** Arbeitsplatte mit offenem Unterbau Schublade - 1 Chromnickelstahlbehälter cm 49x50x15h (inbegriffen 1 Abschluss-Element mod.TPA-7) • **FR** Plan de travail sur armoire ouvert Tiroir - Bac en inox cm 49x50x15h (inclus 1 Élément de jonction top mod.TPA-7) • **ES** Sobre de trabajo sobre mueble abierto Cajón - 1 contenedor cm 49x50x15h de acero inox (incluida 1 Chapa de cierre para top mod.TPA-7)

cm. 60x 70,5x 90h



**1.294,00**  
56 / 0,54

MOD. \_\_\_\_\_  
COD. \_\_\_\_\_

DESCRIZIONE/DESCRIPTION/BEZEICHNUNG/DESCRIPTION/DESCRIPCIÓN  
DIMENSIONI/DIMENSIONS/ABMESSUNGEN/DIMENSIONS/DIMENSIONES

POTENZA/POWER/LEISTUNG/PUISSANCE/POTENCIA  
VOLTAGGIO/VOLTAGE/SPANNUNG/VOLTAGE/VOLTAJE

⚡ kW kcal/h  
⚡ kW V~ Hz

PREZZO/PRICE €  
PREIS/PRIX/PRECIO €  
KG / M<sup>3</sup>

**PL-78**  
08010800

**PIANO LAVORO SU MOBILE A GIORNO  
CASSETTO CON 2 BACINELLE GN 1/1 15H  
PLASTICA (INCLUSA 1 TESTATA CHIUSURA  
PIANO MOD.TPA-7)**

**EN** Worktop on open cabinet Drawer with 2 plastic containers GN 1/1 15h (included 1 Head end filler strip mod.TPA-7) • **DE** Arbeitsplatte mit offenem Unterbau Schublade mit 2 GN 1/1 15h Kunststoffbehälter (inbegriffen 1 Abschluss-Element mod.TPA-7) • **FR** Plan de travail sur armoire ouvert Tiroir avec 2 bacs en plastique GN 1/1 15h (inclus 1 Élément de jonction top mod.TPA-7) • **ES** Sobre de trabajo sobre mueble abierto Cajón con 2 contenedores GN 1/1 15h plástico (incluida 1 Chapa de cierre para top mod.TPA-7)  
**cm. 80x 70,5x 90h**



**1.444,00**  
67 / 0,71

**LA-74**  
08020400

**LAVELLO SU MOBILE A GIORNO RUBINETTO A  
LEVA - VASCA CM. 30X35X15H (INCLUSA 1  
TESTATA CHIUSURA PIANO MOD.TPA-7)**

**EN** Sink unit on open cabinet - Lever type tap. Bowl cm. 30x35x15h (included 1 Head end filler strip mod.TPA-7) • **DE** Spülbecken Einhebel-Mischbatterie mit offenem Unterbau - Becken cm. 30x35x15h (inbegriffen 1 Abschluss-Element mod.TPA-7) • **FR** Bac-évier sur armoire ouvert avec robinetterie - Bac cm. 30x35x15h (inclus 1 Élément de jonction top mod.TPA-7) • **ES** Fregadero sobre mueble abierto - Grifo a palanca - Pileta cm. 30x35x15h (incluida 1 Chapa de cierre para top mod.TPA-7)  
**cm. 40x 70,5x 90h**



**1.157,00**  
45 / 0,37

**P-73/93-DX**  
08430300

**PORTA 300 DESTRA**

**EN** Right door 300 • **DE** Rechte tür 300 • **FR** Porte droite 300 • **ES** Puerta derecha 300  
**cm. 29,5x 2,5x 47,5h**



**157,00**  
3 / 0,01

**P-74/94-DX**  
08430400

**PORTA 400 DESTRA**

**EN** Right door 400 • **DE** Rechte tür 400 • **FR** Porte droite 400 • **ES** Puerta derecha 400  
**cm. 39,5x 2,5x 47,5h**



**163,00**  
3.5 / 0,02

**P-73/93-SX**  
08430301

**PORTA 300 SINISTRA**

**EN** Left door 300 • **DE** Linke tür 300 • **FR** Porte gauche 300 • **ES** Puerta izquierda 300  
**cm. 29,5x 2,5x 47,5h**



**157,00**  
3 / 0,01

**P-74/94-SX**  
08430401

**PORTA 400 SINISTRA**

**EN** Left door 400 • **DE** Linke tür 400 • **FR** Porte gauche 400 • **ES** Puerta izquierda 400  
**cm. 39,5x 2,5x 47,5h**



**163,00**  
3.5 / 0,02

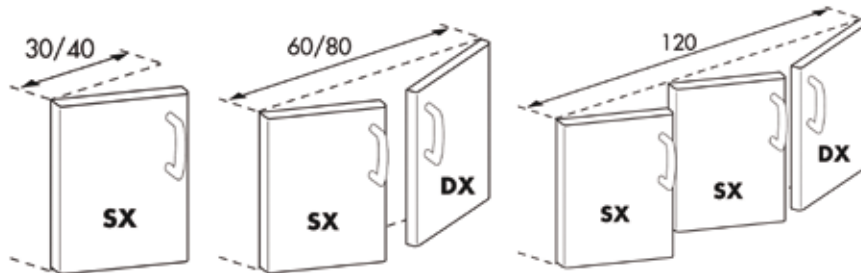

MOD. \_\_\_\_\_  
COD. \_\_\_\_\_

DESCRIZIONE/DESCRIPTION/BEZEICHNUNG/DESCRIPTION/DESCRIPCIÓN  
DIMENSIONI/DIMENSIONS/ABMESSUNGEN/DIMENSIONS/DIMENSIONES

POTENZA/POWER/LEISTUNG/PUISSANCE/POTENCIA  
VOLTAGGIO/VOLTAGE/SPANNUNG/VOLTAGE/VOLTAJE

⚡ kW kcal/h  
⚡ V~ Hz

PREZZO/PRICE €  
PREIS/PRIX/PRECIO €  
KG / M<sup>3</sup>

**C-73/93**  
08440320

**CASSETTIERA 300 N. 2 CASSETTI CON 2 BACINELLE INOX, GUIDE TELESCOPICHE. SOLO SU PL**

**EN** Drawer set 300 N. 2 drawers with 2 inox containers, telescopic guides. Only for PL • **DE** Schubladen 300 - N. 2 Schubladen mit 2 Chromnickelstahlbehältern, Telescopeinführungen. Nur für PL • **FR** Tiroirs pour meuble de 300 N. 2 tiroirs avec 2 bacs inox, guides télescopiques. Seulement pour PL • **ES** Cajonera 300 - N. 2 cajones con 2 contenedores de acero inox, guías telescópicas. Solo para PL  
**cm. 29,5x 59x 47,5h**



**611,00**  
16 / 0,19

**C-74/94**  
08440420

**CASSETTIERA 400 - N. 2 CASSETTI CON 2 BACINELLE GN 1/1 15H IN PLASTICA, GUIDE TELESCOPICHE. SOLO SU PL**

**EN** Drawer set 400 - N. 2 drawers with 2 GN 1/1 15h plastic containers, telescopic guides. Only for PL • **DE** Schubladen - N. 2 Schubladen mit 2 GN 1/1 15h Kunststoffbehältern, Telescopeinführungen. Nur für PL • **FR** Tiroirs pour meuble de 400 - N. 2 tiroirs avec 2 bacs en plastique GN 1/1 15h, guides télescopiques. Seulement pour PL • **ES** Cajonera 400 - N. 2 cajones con 2 contenedores GN 1/1 15h de plástico, guías telescópicas. Solo para PL  
**cm. 39,5x 59x 47,5h**



**627,00**  
18 / 0,19

**C-76/96**  
08440620

**CASSETTIERA 600 N. 2 CASSETTI CON 2 BACINELLE INOX, GUIDE TELESCOPICHE. SOLO SU PL**

**EN** Drawer set 600 N. 2 drawers with 2 inox containers, telescopic guides. Only for PL • **DE** Schubladen 600 - N. 2 Schubladen mit 2 Chromnickelstahlbehältern, Telescopeinführungen. Nur für PL • **FR** Tiroirs pour meuble de 600 N. 2 tiroirs avec 2 bacs inox, guides télescopiques. Seulement pour PL • **ES** Cajonera 600 - N. 2 cajones con 2 contenedores de acero inox, guías telescópicas. Solo para PL  
**cm. 59,5x 59x 47,5h**



**867,00**  
22 / 0,28

**C-78/98**  
08440820

**CASSETTIERA 800 - N. 2 CASSETTI CON 4 BACINELLE GN 1/1 15H IN PLASTICA, GUIDE TELESCOPICHE. SOLO SU PL**

**EN** Drawer set 800 - N. 2 drawers with 4 GN 1/1 15h plastic containers, telescopic guides. Only for PL • **DE** Schubladen 800 - N. 2 Schubladen mit 4 GN 1/1 15h Kunststoffbehältern, Telescopeinführungen. Nur für PL • **FR** Tiroirs pour meuble de 800 - N. 2 tiroirs avec 4 bacs en plastique GN 1/1 15h, guides télescopiques. Seulement pour PL • **ES** Cajonera 800 - N. 2 cajones con 4 contenedores GN 1/1 15h de plástico, guías telescópicas. Solo para PL  
**cm. 79,5x 59x 47,5h**



**883,00**  
26 / 0,37

**SIA-7/9**  
08480000

**STAFFA INFERIORE UNIONE APPARECCHI**

**EN** Lower bracket to join two items

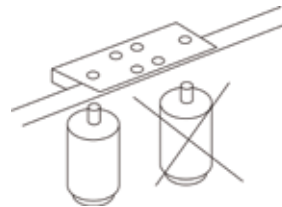

**48,00**  
2 / 0,00

**SR-100**  
50900001

**SET 4 RUOTE Ø 100X30, 2 CON FRENO**

**EN** Set of 4 wheels Ø 100x30, 2 with brake • **DE** 4 Rollen Satz Ø 100x30, 2 davon mit Feststellbremse • **FR** Kit 4 roues Ø 100x30, 2 avec frein • **ES** Equipo 4 ruedas Ø 100x30, 2 con frenos  
**cm. 12,7h**

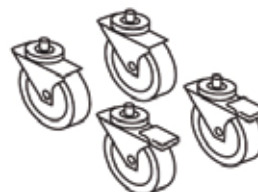

**284,00**  
1 / 0,01

MOD. \_\_\_\_\_  
COD. \_\_\_\_\_

DESCRIZIONE/DESCRIPTION/BEZEICHNUNG/DESCRIPTION/DESCRIPCIÓN  
DIMENSIONI/DIMENSIONS/ABMESSUNGEN/DIMENSIONS/DIMENSIONES

POTENZA/POWER/LEISTUNG/PUISSANCE/POTENCIA  
VOLTAGGIO/VOLTAGE/SPANNUNG/VOLTAGE/VOLTAJE

⚡ kW kcal/h  
⚡ kw V~ Hz

PREZZO/PRICE €  
PREIS/PRIX/PRECIO €  
KG / M<sup>3</sup>

**D-7**  
08470000  
**DIVISORIO**  
**EN** Spacer • **DE** Trennwand • **FR** Separation • **ES** Divisorio  
cm. **5x 59x 45h**

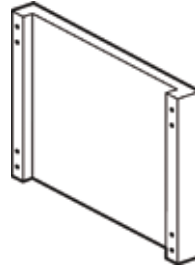

**128,00**  
2.5 / 0,02

**R-74**  
08450400  
**RIPIANO 400 SOLO PL**  
**EN** Shelf 400 Only for PL • **DE** Zwischenboden 400 Nur für PL • **FR** Étagère 400 Seulement pour PL • **ES** Estante 400 Solo para PL  
cm. **35x 59x 2h**

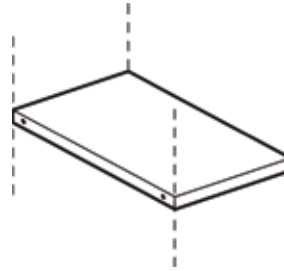

**101,00**  
2 / 0,01

**R-76**  
08450600  
**RIPIANO 600 SOLO PL**  
**EN** Shelf 600 Only for PL • **DE** Zwischenboden 600 Nur für PL • **FR** Étagère 600 Seulement pour PL • **ES** Estante 600 Solo para PL  
cm. **55x 59x 2h**

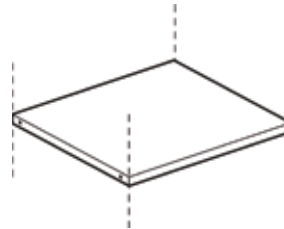

**113,00**  
3 / 0,01

**R-78**  
08450800  
**RIPIANO 800 SOLO PL**  
**EN** Shelf 800 Only for PL • **DE** Zwischenboden 800 Nur für PL • **FR** Étagère 800 Seulement pour PL • **ES** Estante 800 Solo para PL  
cm. **75x 59x 2h**

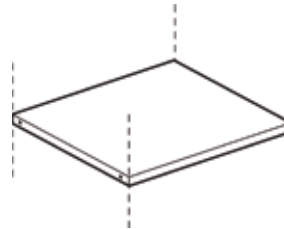

**128,00**  
3.5 / 0,02

**PT-74/94**  
08460002  
**PORTATEGLIE VANO 400/600 (GN-1/1) 4 RIPIANI INT. 7 CM.**  
**EN** Frame for plates 400/600 (GN-1/1) - N. 4 shelves, wheel-base 7 cm. • **DE** Auflangeschienen für bleche 400/600 (GN-1/1) N. 4 Etagen, Abstand 7 cm. • **FR** Kit porte-plaques 400/600 (GN-1/1) - N. 4 étagères; 7 cm. • **ES** Portacazuelas 400/600 (GN-1/1) - N. 4 estantes, int. 7 cm.

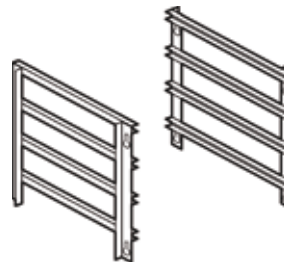

**340,00**  
2.5 / 0,01

**PT-78/98**  
08460012  
**PORTATEGLIE VANO 800 (GN-2/1) 4 RIPIANI INT. 7 CM.**  
**EN** Frame for plates 800 (GN-2/1) 4 Etagen, Abstand 7 cm. • **DE** Auflangeschienen für bleche 800 (GN-2/1) N. 4 Etagen, Abstand 7 cm. • **FR** Kit porte-plaques 800 (GN-2/1) - N. 4 étagères; 7 cm. • **ES** Portacazuelas 800 (GN-2/1) - N. 4 estantes, int. 7 cm.

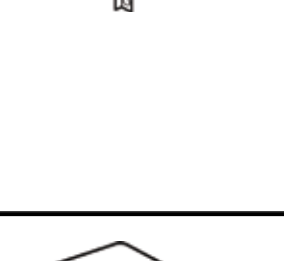

**453,00**  
4 / 0,01

**08550400**  
**COPERCHIO BRF-74**  
**EN** Lid BRF-74 • **DE** Deckel BRF-74 • **FR** Couverture BRF-74 • **ES** Tapa BRF-74  
cm. **32x 53x 5h**

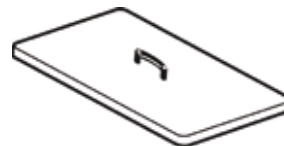

**113,00**  
2 / 0,02

**08550800**  
**COPERCHIO BRF-78**  
**EN** Lid BRF-78 • **DE** Deckel BRF-78 • **FR** Couverture BRF-78 • **ES** Tapa BRF-78  
cm. **72x 53x 5h**

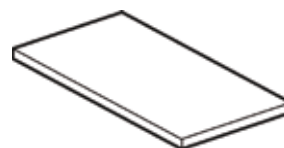

**151,00**  
4 / 0,03

**TG-4**  
07580400  
**TAGLIERE PLASTICA**  
**EN** Plastic chopping-board • **DE** Schneidebrett • **FR** Plan de découpe • **ES** Picador de plástico  
cm. **39x 58x 2,5h**

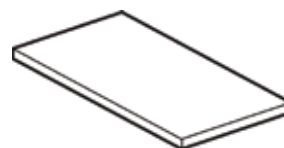

**126,00**  
6 / 0,01

# ACCESSORI

MOD. COD.	DESCRIZIONE/DESCRIPTION/BEZEICHNUNG/DESCRIPTION/DESCRIPCIÓN DIMENSIONI/DIMENSIONS/ABMESSUNGEN/DIMENSIONS/DIMENSIONES	POTENZA/POWER/LEISTUNG/PUISSANCE/POTENCIA VOLTAGGIO/VOLTAGE/SPANNUNG/VOLTAGE/VOLTAJE	⚡ kcal/h kw V~ Hz	PREZZO/PRICE € PREIS/PRIX/PRECIO / KG / M <sup>3</sup>
<b>TG-6</b> 07580600	<b>cm. 59x 58x 2,5h</b>			<b>186,00</b> 9 / 0,02
<b>TG-8</b> 07580800	<b>cm. 79x 58x 2,5h</b>			<b>240,00</b> 11 / 0,02
<b>OPT-GA</b>	<b>ACCENSIONE ELETTRICA PER APPARECCHI GAS: PC-74GA, PC-78GA, PC-712GA, PC-716GA, PCT-74GA, PCT-78GA, PCT-712GA, PCT-716GA, CF6-712GAV, CF6-712GA, CF4-78GA - CF4-78GAE, CF6-712GAEV, CF6-712GAE, CFV4-78GAE, CFV6-712GAEV (PREZZO A BRUCIATORE)</b> <b>EN</b> electric ignition for gas model: PC-74GA, PC-78GA, PC-712GA, PC-716GA, PCT-74GA, PCT-78GA, PCT-712GA, PCT-716GA, CF6-712GAV, CF6-712GA, CF4-78GA - CF4-78GAE, CF6-712GAEV, CF6-712GAE, CFV4-78GAE, CFV6-712GAEV (PRICE FOR 1 BURNER) • <b>DE</b> elektrische Zündung für gas modell: PC-74GA, PC-78GA, PC-712GA, PC-716GA, PCT-74GA, PCT-78GA, PCT-712GA, PCT-716GA, CF6-712GAV, CF6-712GA, CF4-78GA - CF4-78GAE, CF6-712GAEV, CF6-712GAE, CFV4-78GAE, CFV6-712GAEV (PREIS FÜR 1 BRENNER) • <b>FR</b> allumage électrique pour modèle a gaz: PC-74GA, PC-78GA, PC-712GA, PC-716GA, PCT-74GA, PCT-78GA, PCT-712GA, PCT-716GA, CF6-712GAV, CF6-712GA, CF4-78GA - CF4-78GAE, CF6-712GAEV, CF6-712GAE, CFV4-78GAE, CFV6-712GAEV (PRIX POUR 1 BRÛLEUR) • <b>ES</b> ignición eléctrica para modelo gas: PC-74GA, PC-78GA, PC-712GA, PC-716GA, PCT-74GA, PCT-78GA, PCT-712GA, PCT-716GA, CF6-712GAV, CF6-712GA, CF4-78GA - CF4-78GAE, CF6-712GAEV, CF6-712GAE, CFV4-78GAE, CFV6-712GAEV (PRECIO POR 1 QUEMADOR)		⚡ 0,01 KW 230V~ 50/60 Hz	<b>200,00</b> /
<b>532005901</b>	<b>GRIGLIA 1 FUOCO</b> <b>EN</b> 1 flame grill • <b>DE</b> Rost 1 flamme • <b>FR</b> Frille 1 feu • <b>ES</b> Parrilla 1 quemador			<b>86,00</b> 3 / 0,01
<b>544439900</b>	<b>ANELLO PER WOK - SOLO PER GRIGLIE IN GHISA</b> <b>EN</b> Wok ring - only for cast iron grills • <b>DE</b> Wok Aufsatzring - nur für Roste aus Gusseisen • <b>FR</b> Anneau Wok - seulement pour grilles en fonte • <b>ES</b> Anillo Wok - solo para parrillas de hierro colado <b>cm. Ø22,5x 3,5h</b>			<b>126,00</b> 2 / 0,00
<b>PLF</b> 07590401	<b>PIASTRA LISCIA PER GRIGLIA IN GHISA</b> <b>EN</b> Smooth griddle plate for cast iron grid • <b>DE</b> Fortkochplatte glatt für Gusseisen Rost • <b>FR</b> Plaque lisse pour la grille en fonte • <b>ES</b> Plancha lisa para rejilla de hierro fundido <b>cm. 35x 27</b>			<b>151,00</b> 9 / 0,01
<b>PLF/2</b> 07590421	<b>PIASTRA LISCIA 2 FUOCHI PER GRIGLIA IN GHISA</b> <b>EN</b> Smooth griddle plate 2 burners for cast iron grid • <b>DE</b> Fortkochplatte glatt 2 Kochstellen für Gusseisen Rost • <b>FR</b> Plaque lisse 2 feux pour la grille en fonte • <b>ES</b> Plancha lisa 2 quemadores para rejilla de hierro fundido <b>cm. 35x 57</b>			<b>299,00</b> 18 / 0,01



# ACCESSORI

MOD. \_\_\_\_\_  
COD. \_\_\_\_\_

DESCRIZIONE/DESCRIPTION/BEZEICHNUNG/DESCRIPTION/DESCRIPCIÓN  
DIMENSIONI/DIMENSIONS/ABMESSUNGEN/DIMENSIONS/DIMENSIONES

POTENZA/POWER/LEISTUNG/PUISSANCE/POTENCIA  
VOLTAGGIO/VOLTAGE/SPANNUNG/VOLTAGE/VOLTAJE

⚡ kW kcal/h  
⚡ kw V~ Hz

PREZZO/PRICE €  
PREIS/PRIX/PRECIO €  
KG / M<sup>3</sup>

**PRF**  
07590403

**PIASTRA RIGATA PER GRIGLIA IN GHISA**  
**EN** Grooved griddle plate for cast iron grid • **DE** Fortkochplatte gerillt für Gusseisen Rost • **FR** Plaque nervurée pour la grille en fonte • **ES** Plancha estriada para rejilla de hierro fundido  
**cm. 35x 27**

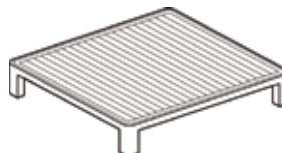

**203,00**  
9 / 0,01

**PRF/2**  
07590423

**PIASTRA RIGATA 2 FUOCHI PER GRIGLIA IN GHISA**  
**EN** Grooved griddle plate 2 burners for cast iron grid • **DE** Fortkochplatte gerillt 2 Kochstellen für Gusseisen Rost • **FR** Plaque nervurée 2 feux pour la grille en fonte • **ES** Plancha estriada 2 quemadores para rejilla de hierro fundido  
**cm. 35x 57**



**332,00**  
18 / 0,01

**PLFT/7**  
08590451

**PIASTRA LISCIA PER GRIGLIA IN TONDINO**  
**EN** Smooth griddle plate for grid rod • **DE** Fortkochplatte glatt für Gitterstab • **FR** Plaque lisse pour tige grille • **ES** Plancha lisa por red de varilla  
**cm. 35x 27**



**151,00**  
9 / 0,01

**PLFT/72**  
08590471

**PIASTRA LISCIA 2 FUOCHI PER GRIGLIA IN TONDINO**  
**EN** Smooth griddle plate 2 burners for grid rod • **DE** Fortkochplatte glatt 2 Kochstellen für Gitterstab • **FR** Plaque lisse 2 feux pour tige grille • **ES** Plancha lisa 2 quemadores por red de varilla  
**cm. 35x 57**



**299,00**  
18 / 0,01

**PRFT/7**  
08590453

**PIASTRA RIGATA PER GRIGLIA IN TONDINO**  
**EN** Grooved griddle plate for grid rod • **DE** Fortkochplatte gerillt für Gitterstab • **FR** Plaque nervurée pour tige grille • **ES** Plancha estriada por red de varilla  
**cm. 35x 27**

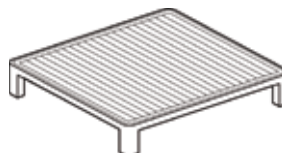

**203,00**  
9 / 0,01

**PRFT/72**  
08590473

**PIASTRA RIGATA 2 FUOCHI PER GRIGLIA IN TONDINO**  
**EN** Grooved griddle plate 2 burners for grid rod • **DE** Fortkochplatte gerillt 2 Kochstellen für Gitterstab • **FR** Plaque nervurée 2 feux pour tige grille • **ES** Plancha estriada 2 quemadores por red de varilla  
**cm. 35x 57**



**332,00**  
18 / 0,01

**533009200 GRIGLIA DI RIDUZIONE**

**EN** Reduction • **DE** Reduzierstern • **FR** Grille de réduction • **ES** Rejilla de reducción  
**cm. 25x 25**



**31,00**  
0.2 / 0,00

**RV**  
08660410

**RISCALDANTE VANO CUCINA**  
**EN** Heater for range's cabinet • **DE** Heizer für Herden-Schränkelement • **FR** Réchauffeur pour armoire du fourneau • **ES** Calefacción para armario neutro de la cocina  
**cm. 32x 48,5x 8h**

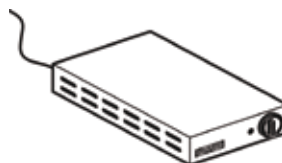

⚡ 0,75 kW  
230V~  
50/60 Hz

**721,00**  
8 / 0,08



Le immagini presentate non sono vincolanti. La ditta si riserva di apportare modifiche senza preavviso. • The pictures are purely representative. The manufacturer reserves the right to modify the technical data and models without previous notice. • Les images

LO

présentées ne nous engagent pas. La Société se réserve le droit d'apporter tout modification sans préavis. • Die dargestellten Abbildungen sind nicht verbindlich. Technische Änderungen vorbehalten. • Las imágenes presentadas no son vinculantes. El Fabricante se reserva el derecho de modificar sus productos sin previo aviso.

01/20

**179**

# ACCESSORI

MOD. \_\_\_\_\_ DESCRIZIONE/DESCRIPTION/BEZEICHNUNG/DESCRIPTION/DESCRIPCIÓN POTENZA/POWER/LEISTUNG/PUISSANCE/POTENCIA ⚡kW ⚡kw PREZZO/PRICE €  
 COD. \_\_\_\_\_ DIMENSIONI/DIMENSIONS/ABMESSUNGEN/DIMENSIONS/DIMENSIONES VOLTAGGIO/VOLTAGE/SPANNUNG/VOLTAGE/VOLTAJE kcal/h kcal/h V~ Hz PREIS/PRIX/PRECIO €  
 KG / M<sup>3</sup>

**RCRV-74** **RIPIANO FORATO IN APPOGGIO PER RISCALDANTE SU VANO CUCINA** **280,00**  
 08450402

**EN** Perforated shelf for heater element mod.RV for cooker cabinet • **DE** regale Gelocht für Heizer mod. RV für Herden-Schränkelement • **FR** Étagère perforées pour réchauffeur mod.RV pour armoire du fourneau • **ES** estante perforado para elemento de calefaccion mod.RV para armario neutro de la cocina  
**cm. 34x 55x 10h**



**RRV-74** **RIPIANO FORATO IN APPOGGIO PER RISCALDANTE** **280,00**  
 08450401

**EN** Perforated shelf for heater element mod.RV • **DE** regale Gelocht für Heizer mod.RV • **FR** Étagère perforées pour réchauffeur mod.RV • **ES** estante perforado para elemento de calefaccion mod.RV  
**cm. 34x 57x 10h**

**RRV-76** **cm. 54x 57x 10h** **430,00**  
 08450601

**RRV-78** **cm. 74x 57x 10h** **618,00**  
 08450801

**RRV-710** **cm. 94x 57x 10h** **774,00**  
 08451001

**RRV-712** **cm. 114x 57x 10h** **991,00**  
 08451201

**RRV-716** **cm. 154x 57x 10h** **1.262,00**  
 08451601



**08570401** **GRIGLIA TONDINO PER CW (SERIE 70)** **336,00**  
**EN** Grid for CW (70 line) • **DE** Gitter für CW (70. Serie) • **FR** Grille ronde pour CW (serie 70) • **ES** Rejilla para CW (serie 70)  
**cm. 36x 51x** 11 / 0,03

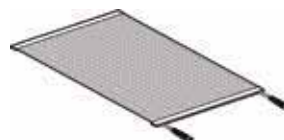

**08570402** **GRIGLIA TEGOLO V PER CW (SERIE 70)** **336,00**  
**EN** Grid V for CW (70 line) • **DE** Gitter V für CW (70. Serie) • **FR** Grille V pour CW (serie 70) • **ES** Rejilla V para CW (serie 70)  
**cm. 36x 51x** 11 / 0,03

**544023800** **RASCHIETTO PER PIASTRA RIGATA** **50,00**  
**EN** Scraper for gooved plate • **DE** Schaber für gerillte Kochplatte • **FR** Racloir pour plaque nervurée • **ES** Rasqueta para placa ranurada  
 / 1,00



**531040800** **RASCHIETTO PER PIASTRA LISCIA CROMATA** **47,00**  
**EN** Scraper for smooth chromed plate • **DE** Schaber für glatte verchromte Platte • **FR** Racloir pour plaque lisse au chrome • **ES** Rasqueta para placa lisa cromada  
 / 1,00



# ACCESSORI FRY-TOP

MOD. \_\_\_\_\_  
COD. \_\_\_\_\_

DESCRIZIONE/DESCRIPTION/BEZEICHNUNG/DESCRIPTION/DESCRIPCIÓN  
DIMENSIONI/DIMENSIONS/ABMESSUNGEN/DIMENSIONS/DIMENSIONES

POTENZA/POWER/LEISTUNG/PUISSANCE/POTENCIA  
VOLTAGGIO/VOLTAGE/SPANNUNG/VOLTAGE/VOLTAJE

⚡ kW kcal/h  
⚡ kw V~ Hz

PREZZO/PRICE €  
PREIS/PRIX/PRECIO €  
KG / M<sup>3</sup>

## 531040900 KIT 10 LAME PER RASCHIETTO

EN 10 blades kit for scraper • DE Kit 10 Klingen für Schaber • FR Kit de 10 lames pour racloir • ES Kit de 10 cuchillas para rasqueta

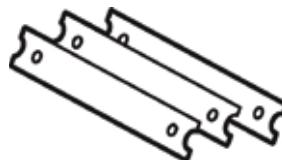

33,00  
/ 0,00

T-FT  
09580060

## TAPPO PER FRY-TOP

EN stopper for Fry-top • DE Stopfen griddleplatte • FR bouchon pour Plaque • ES tapón Fry-top  
cm. 10x 2x 5h

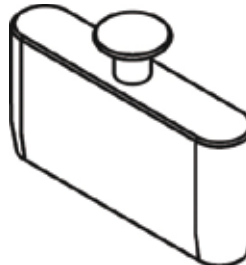

198,00  
/ 0,00

PFT-74  
08620400

KIT PROTEZIONE FRONTALE PIANO FRY-TOP  
EN KIT front protection plan fry-top • DE Schutz-kit vorne Plan griddleplatte • FR KIT protection avant plan plaque • ES KIT de protección frontal plan de fry-top  
cm. 35x 8x 6h

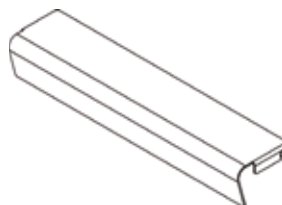

102,00  
/ 0,00

PFT-76  
08620600

cm. 55x 8x 6h

137,00  
/ 0,01

PFT-78  
08620800

cm. 75x 8x 6h

172,00  
/ 0,01

PFT-712  
08621200

cm. 115x 8x 6h

195,00  
/ 0,01

## KF-F-ETD S70 KIT 100 FILTRI 5 MICRON PER F-ETD S70

546003402 EN KIT 100 sieve 5 microns for F-ETD S70 • DE KIT 100 Filter 5-Mikron für F-ETD S70 • FR KIT 100 filtre 5 microns pour F-ETD S70 • ES KIT 100 filtro de 5 micrones para F-ETD S70



320,00  
0.1 / 0,00

## 531013200 CESTINO 1/2 PER F13-G/E

EN Basket 1/2 for F13-G/E • DE Korb 1/2 für F13-G/E • FR Panier 1/2 pour F13-G/E • ES Cesta 1/2 para F13-G/E  
cm. 10x 30x 12h



47,00  
0.7 / 0,03

## 531013500 CESTINO 1/2 PER F18-70G

EN Basket 1/2 for F18-70G • DE Korb 1/2 für F18-70G • FR Panier 1/2 pour F18-70G • ES Cesta 1/2 para F18-70G  
cm. 14x 33x 12h



57,00  
0.8 / 0,04

## 531041600 CESTINO 1/2 PER F18-E (STANDARD IN F18-ETD)

EN Basket 1/2 for F18-E (standard F18-ETD) • DE Korb 1/2 zur Friteuse F18-E (standard F18-ETD) • FR Panier 1/2 pour F18-E (standard F18-ETD) • ES Cesta 1/2 para F18-E (standard F18-ETD)  
cm. 13,5x 29x 15h

62,00  
0.8 / 0,04



Le immagini presentate non sono vincolanti. La ditta si riserva di apportare modifiche senza preavviso. • The pictures are purely representative. The manufacturer reserves the right to modify the technical data and models without previous notice. • Les images

LO

présentées ne nous engagent pas. La Société se réserve le droit d'apporter tout modification sans préavis. • Die dargestellten Abbildungen sind nicht verbindlich. Technische Änderungen vorbehalten. • Las imágenes presentadas no son vinculantes. El Fabricante se reserva el derecho de modificar sus productos sin previo aviso.

01/20

181

70

# ACCESSORI FRIGGITRICI

MOD. \_\_\_\_\_  
COD. \_\_\_\_\_

DESCRIZIONE/DESCRIPTION/BEZEICHNUNG/DESCRIPTION/DESCRIPCIÓN  
DIMENSIONI/DIMENSIONS/ABMESSUNGEN/DIMENSIONS/DIMENSIONES

POTENZA/POWER/LEISTUNG/PUISSANCE/POTENCIA  
VOLTAGGIO/VOLTAGE/SPANNUNG/VOLTAGE/VOLTAJE

⚡ kW kcal/h  
⚡ kw V~ Hz

PREZZO/PRICE €  
PREIS/PRIX/PRECIO €  
KG / M<sup>3</sup>

## 531033300 CESTINO 1/1 F45

EN Basket 1/1 F45 • DE korb 1/1 F45 • FR Panier 1/1 F45 • ES Cesta 1/1 F45  
cm. 65x 33x 17h



162,00  
3 / 0,10

## 531041300 CESTINO 1/2 F45, 1/1 PER F18-ETD (STANDARD IN F18-E)

EN Basket 1/2 F45, 1/1 for F18-ETD (standard F18-E)  
• DE korb 1/2 F45, 1/1 für F18-ETD (standard F18-E)  
• FR Panier 1/2 F45, 1/1 pour F18-ETD (standard F18-E)  
• ES Cesta 1/2 F45, 1/1 para F18-ETD (standard F18-E)  
cm. 28x 29x 15h



68,00  
1.5 / 0,06

## 531047800 CESTINO 1/3 F45

EN Basket 1/3 F45 • DE korb 1/3 F45 • FR Panier 1/3 F45 • ES Cesta 1/3 F45  
cm. 21,5x 33x 16,5h



79,00  
1.3 / 0,06

## 40280800 SCIVOLO INOX F45

EN Stainless steel slide F45 • DE Rutsche aus Rostfreiem Stahl F45 • FR Goulotte en acier inox F45 • ES Deslizador inox F45  
cm. 38x 75x 27h

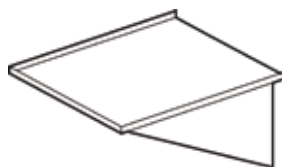

126,00  
5 / 0,09

## 531070200 CESTO 1/1 PER CP-74/78

EN Basket 1/1 for CP-74/78 • DE Korb 1/1 für CP-74/78 • FR Panier 1/1 pour CP-74/78 • ES Cesta 1/1 para CP-74/78  
cm. 28x 32x 21,5h



136,00  
2 / 0,06

## 531032400 CESTO 1/2 PER CP-74/78

EN Basket 1/2 for CP-74/78 • DE Korb 1/2 für CP-74/78 • FR Panier 1/2 pour CP-74/78 • ES Cesta 1/2 para CP-74/78  
cm. 14x 32x 20h

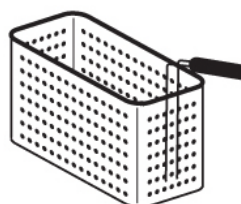

94,00  
1.5 / 0,05

..324..

## 531047900 cm. 28x 16x 21,5h



98,00  
1.5 / 0,04

# ACCESSORI CUOCIPASTA

MOD. \_\_\_\_\_  
COD. \_\_\_\_\_

DESCRIZIONE/DESCRIPTION/BEZEICHNUNG/DESCRIPTION/DESCRIPCIÓN  
DIMENSIONI/DIMENSIONS/ABMESSUNGEN/DIMENSIONS/DIMENSIONES

POTENZA/POWER/LEISTUNG/PUISSANCE/POTENCIA  
VOLTAGGIO/VOLTAGE/SPANNUNG/VOLTAGE/VOLTAJE

⚡ kW kcal/h  
⚡ kw V~ Hz

PREZZO/PRICE €  
PREIS/PRIX/PRECIO €  
KG / M<sup>3</sup>

## 531048000 CESTO 1/4 PER CP-74/78

EN Basket 1/4 for CP-74/78 • DE Korb 1/4 für CP-74/78 • FR Panier 1/4 pour CP-74/78 • ES Cesta 1/4 para CP-74/78  
cm. 13,5x 16x 21,5h



**75,00**  
1 / 0,02

## 531032600 CESTO 1/6 PER CP-74/78

EN Basket 1/6 for CP-74/78 • DE Korb 1/6 für CP-74/78 • FR Panier 1/6 pour CP-74/78 • ES Cesta 1/6 para CP-74/78  
cm. 14x 10x 20h



**67,00**  
0.7 / 0,02

..326..

## 531053900 CESTO 1/1 PER CP-76

EN Basket 1/1 for CP-76 • DE Korb 1/1 für CP-76 • FR Panier 1/1 pour CP-76 • ES Cesta 1/1 para CP-76  
cm. 49x 29x 20h

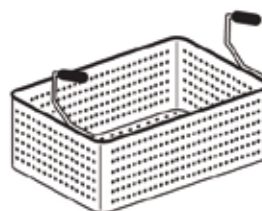

**147,00**  
3,5 / 0,08

..539..

## 531017900 CESTO 1/3 PER CP-76

EN Basket 1/3 for CP-76 • DE Korb 1/3 für CP-76 • FR Panier 1/3 pour CP-76 • ES Cesta 1/3 para CP-76  
cm. 16x 29x 20h

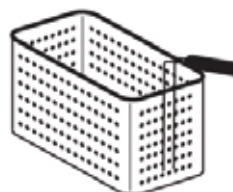

**107,00**  
1,5 / 0,05

..179..

## 531064300 CESTO 1/4 PER CP-76

EN Basket 1/4 for CP-76 • DE Korb 1/4 für CP-76 • FR Panier 1/4 pour CP-76 • ES Cesta 1/4 para CP-76  
cm. 11,5x 29x 20h

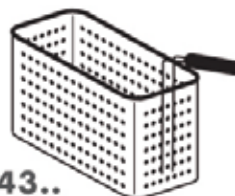

**95,00**  
1,2 / 0,04

..643..

## 531071100 CESTO CON GANCIO 1/2 PER CP-74/78

EN Basket with hook 1/2 for CP-74/78 • DE Korb mit Haken 1/2 für CP-74/78 • FR Panier avec crochet 1/2 pour CP-74/78 • ES Cesta con gancho 1/2 para CP-74/78  
cm. 14,5x 29x 20h



**131,00**  
1.5 / 0,05

## 531071200 CESTO CON GANCIO 1/3 PER CP-76

EN Basket with hook 1/3 for CP-76 • DE Korb mit Haken 1/3 für CP-76 • FR Panier avec crochet 1/3 pour CP-76 • ES Cesta con gancho 1/3 para CP-76  
cm. 15x 26x 20h

**116,00**  
1,5 / 0,05



Le immagini presentate non sono vincolanti. La ditta si riserva di apportare modifiche senza preavviso. • The pictures are purely representative. The manufacturer reserves the right to modify the technical data and models without previous notice. • Les images

LO

présentées ne nous engagent pas. La Société se réserve le droit d'apporter tout modification sans préavis. • Die dargestellten Abbildungen sind nicht verbindlich. Technische Änderungen vorbehalten. • Las imágenes presentadas no son vinculantes. El Fabricante se reserva el derecho de modificar sus productos sin previo aviso.

01/20

183

70



# ACCESSORI CUOCIPASTA

MOD. \_\_\_\_\_  
COD. \_\_\_\_\_

DESCRIZIONE/DESCRIPTION/BEZEICHNUNG/DESCRIPTION/DESCRIPCIÓN  
DIMENSIONI/DIMENSIONS/ABMESSUNGEN/DIMENSIONS/DIMENSIONES

POTENZA/POWER/LEISTUNG/PUISSANCE/POTENCIA  
VOLTAGGIO/VOLTAGE/SPANNUNG/VOLTAGE/VOLTAJE

↓ kW kcal/h  
↑ kW V~ Hz

PREZZO/PRICE €  
PREIS/PRIX/PRECIO €  
KG / M<sup>3</sup>

**531018700 CESTO CON GANCIO 1/4 PER CP-76**  
EN Basket with hook 1/4 for CP-76 • DE Korb mit Haken 1/4 für CP-76 • FR Panier avec crochet 1/4 pour CP-76 • ES Cesta con gancho 1/4 para CP-76  
cm. 11x 26x 20h



**96,00**  
1,2 / 0,04

**531069300 GRIGLIA SUPPORTO CESTI CON GANCIO PER CP-74/78**  
EN support for baskets with hook for CP-74/78 • DE Unterstützung für Körbe mit Haken für CP-74/78 • FR soutien pour les paniers avec crochet pour CP-74/78 • ES soporte para cestas con gancho para CP-74/78  
cm. 30x 33x 41h



**112,00**  
3.5 / 0,06

**531069400 GRIGLIA SUPPORTO CESTI CON GANCIO PER CP-76**  
EN support for baskets with hook for CP-76 • DE Unterstützung für Körbe mit Haken für CP-76 • FR soutien pour les paniers avec crochet pour CP-76 • ES soporte para cestas con gancho para CP-76  
cm. 50x 29x 41h



**145,00**  
4 / 0,09

**SA-72/92 SCHIENA POSTERIORE A VISTA PER APPARECCHI**  
08600200 EN Back cover • DE Rückenwand • FR Dos de finition • ES panel posterior  
cm. 20x 1,5x 81h



**83,00**  
2 / 0,01

**SA-73/93** cm. 30x 1,5x 81h  
08600300

**94,00**  
3 / 0,01

**SA-74/94** cm. 40x 1,5x 81h  
08600400

**108,00**  
3 / 0,01

**SA-75/95** cm. 50x 1,5x 81h  
08600500

**135,00**  
4 / 0,01

**SA-76/96** cm. 60x 1,5x 81h  
08600600

**156,00**  
4 / 0,02

**SA-77/97** cm. 70x 1,5x 81h  
08600700

**167,00**  
5 / 0,02

**SA-78/98** cm. 80x 1,5x 81h  
08600800

**183,00**  
5 / 0,02

**SA-79/99** cm. 90x 1,5x 81h  
08600900

**205,00**  
6 / 0,02

**SA-710/910** cm. 100x 1,5x 81h  
08601000

**228,00**  
6 / 0,03

# ACCESSORI

MOD. \_\_\_\_\_  
COD. \_\_\_\_\_

DESCRIZIONE/DESCRIPTION/BEZEICHNUNG/DESCRIPTION/DESCRIPCIÓN  
DIMENSIONI/DIMENSIONS/ABMESSUNGEN/DIMENSIONS/DIMENSIONES

POTENZA/POWER/LEISTUNG/PUISSANCE/POTENCIA  
VOLTAGGIO/VOLTAGE/SPANNUNG/VOLTAGE/VOLTAJE

⚡ kW kcal/h  
⚡ kw V~ Hz

PREZZO/PRICE €  
PREIS/PRIX/PRECIO €  
KG / M<sup>3</sup>

**SA-711/911 cm. 110x 1,5x 81h**  
08601100

**SA-712/912 cm. 120x 1,5x 81h**  
08601200

**SA-713/913 cm. 130x 1,5x 81h**  
08601300

**SA-714/914 cm. 140x 1,5x 81h**  
08601400

**SA-715/915 cm. 150x 1,5x 81h**  
08601500

**SA-716/916 cm. 160x 1,5x 81h**  
08601600

**SA-74FG 08600401** **SCHIENA POSTERIORE A VISTA PER FRIGGITRICI GAS (NO F2/8-74G)**  
**EN** Back cover for Gas Fryer (no F2/8-74G) • **DE** Rückenwand für Gas-Friteuse (no F2/8-74G) • **FR** Dos de finition pour Friteuse a gaz (no F2/8-74G) • **ES** panel posterior para Freidoras a gas (no F2/8-74G)  
**cm. 40x 1,5x 94h**

**SA-78FG 08600801** **SCHIENA POSTERIORE A VISTA PER FRIGGITRICI GAS**  
**EN** Back cover for Gas Fryer • **DE** Rückenwand für Gas-Friteuse • **FR** Dos de finition pour Friteuse a gaz • **ES** panel posterior para Freidoras a gas  
**cm. 80x 1,5x 94h**

**SA-78F45G 08600803** **SCHIENA POSTERIORE A VISTA PER FRIGGITRICE GAS F45-78G**  
**EN** Back cover for Gas Fryer F45-78G • **DE** Rückenwand für Gas-Friteuse F45-78G • **FR** Dos de finition pour Friteuse a gaz F45-78G • **ES** panel posterior para Freidoras a gas F45-78G  
**cm. 80x 1,5x 121h**



**251,00**  
7 / 0,03

**274,00**  
7 / 0,03

**297,00**  
8 / 0,03

**319,00**  
8 / 0,04

**342,00**  
10 / 0,04

**365,00**  
10 / 0,04

**125,00**  
3 / 0,01

**199,00**  
5 / 0,02

**207,00**  
6 / 0,03

**KIT-TOPM-SA 08600001** **KIT TAMPONAMENTI LATERALI PER SCHIENA POSTERIORE MONTATA SU APPARECCHI TOP MOBILI "M-.."**

**EN** Side KIT for back cover mounted on the TOP machine and Stand "M-.." • **DE** Seitliches KIT für Rückenwand montiert auf der TOP-Maschine und Unterbau "M-.." • **FR** KIT latéral pour Dos de finition monté sur la machine TOP et Placard "M-.." • **ES** KIT lateral para panel posteriore montado en la máquina TOP y Mueble base "M-.."

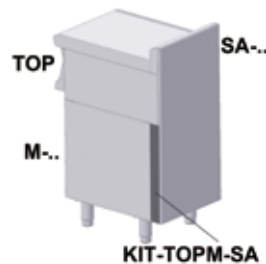

**73,00**  
1 / 0,01

**TPA-7 08560001** **TESTATA CHIUSURA PIANO (IN DOTAZIONE 1 PEZZO PER APPARECCHIO)**

**EN** Head end filler strip (1 piece included in each machine) • **DE** Abschluss-Element (1 Stück in jeder Maschine enthalten) • **FR** Élément de jonction top (1 pièce incluse dans chaque machine) • **ES** Chapa de cierre para top (1 pieza incluida en cada equipo)  
**cm. 0,2x 70,5**



**57,00**  
1 / 0,00

# ACCESSORI

MOD. \_\_\_\_\_  
COD. \_\_\_\_\_

DESCRIZIONE/DESCRIPTION/BEZEICHNUNG/DESCRIPTION/DESCRIPCIÓN  
DIMENSIONI/DIMENSIONS/ABMESSUNGEN/DIMENSIONS/DIMENSIONES

POTENZA/POWER/LEISTUNG/PUISSANCE/POTENCIA  
VOLTAGGIO/VOLTAGE/SPANNUNG/VOLTAGE/VOLTAJE

⚡ kW kcal/h  
⚡ kw V~ Hz

PREZZO/PRICE €  
PREIS/PRIX/PRECIO €  
KG / M<sup>3</sup>

**TMA-75X**  
08540701

**TESTATA 1 LATO SERIE 70 SINISTRA**  
**EN** Head 1 side S70 left • **DE** Abschluss element 1 seite S70 links • **FR** Element de jonction 1 coté S70 gauche  
• **ES** Embellecedor 1 lado S70 izquierda  
**cm. 0,2x 70,5**



**207,00**  
8 / 1,00

**TMA-7DX**  
08540700

**TESTATA 1 LATO SERIE 70 DESTRA**  
**EN** Head 1 side S70 right • **DE** Abschluss element 1 seite S70 recht • **FR** Element de jonction 1 coté S70 droit • **ES** Embellecedor 1 lado S70 derecha  
**cm. 0,2x 70,5**



**207,00**  
8 / 1,00

**TMA-77**  
08547700

**TESTATA 2 LATI SERIE 70**  
**EN** Head 2 sides S70 • **DE** Abschluss element seiten S70 • **FR** Element de jonction 2 cotés S70 • **ES** Embellecedor 2 lados S70  
**cm. 0,2x 141**



**414,00**  
16 / 1,00

**TMA-79SX**  
08547901

**TESTATA 2 LATI SERIE 70/90 SINISTRA**  
**EN** Head 2 sides S70/90 left • **DE** Abschluss element seiten S70/90 links • **FR** Element de jonction 2 cotés S70/90 gauche • **ES** Embellecedor 2 lados S70/90 izquierda  
**cm. 0,2x160,5**



**425,00**  
18 / 1,00

**TMA-79DX**  
08547900

**TESTATA 2 LATI SERIE 70/90 DESTRA**  
**EN** Head 2 sides S70/90 right • **DE** Abschluss element seiten S70/90 recht • **FR** Element de jonction 2 cotés S70/90 droit • **ES** Embellecedor 2 lados S70/90 derecha  
**cm. 0,2x160,5**



**425,00**  
18 / 1,00

**TMTA-7SX**  
08540721

**TESTATA TAMBURATA 1 LATO SERIE 70 SINISTRA, CON STESSO PROFILO LINEA FRONTALE**  
**EN** Head 1 side S70 left, with the same front line profile  
• **DE** Abschluss element 1 seite S70 links, mit dem gleichen Frontlinienprofil • **FR** Element de jonction 1 coté S70 gauche, avec le même profil de ligne • **ES** Embellecedor 1 lado S70 izquierda, con el mismo perfil de línea frontal  
**cm. 7,5x 70,5**



**650,00**  
14 / 1,00

MOD. \_\_\_\_\_  
COD. \_\_\_\_\_

DESCRIZIONE/DESCRIPTION/BEZEICHNUNG/DESCRIPTION/DESCRIPCIÓN  
DIMENSIONI/DIMENSIONS/ABMESSUNGEN/DIMENSIONS/DIMENSIONES

POTENZA/POWER/LEISTUNG/PUISSANCE/POTENCIA  
VOLTAGGIO/VOLTAGE/SPANNUNG/VOLTAGE/VOLTAJE

⚡ kW kcal/h  
⚡ kw V~ Hz

PREZZO/PRICE €  
PREIS/PRIX/PRECIO €  
KG / M<sup>3</sup>

**TMTA-7DX**  
08540720

**TESTATA TAMBURATA 1 LATO SERIE 70 DESTRA, CON STESSO PROFILO LINEA FRONTALE**

**EN** Head 1 side S70 right, with the same front line profile • **DE** Abschluss element 1 seite S70 recht, mit dem gleichen Frontlinienprofil • **FR** Element de jonction 1 coté S70 droit, avec le même profil de ligne • **ES** Embellecedor 1 lado S70 derecha, con el mismo perfil de línea frontal  
**cm. 7,5x 70,5**



**650,00**  
14 / 1,00

**TMTA-77**  
08547720

**TESTATA TAMBURATA 2 LATI SERIE 70, CON STESSO PROFILO LINEA FRONTALE**

**EN** Head 2 sides S70, with the same front line profile • **DE** Abschluss element seiten S70, mit dem gleichen Frontlinienprofil • **FR** Element de jonction 2 cotés S70, avec le même profil de ligne • **ES** Embellecedor 2 lados S70, con el mismo perfil de línea frontal  
**cm. 7,5x 141**



**1.260,00**  
28 / 1,00

**TMTA-79SX**  
08547921

**TESTATA TAMBURATA 2 LATI SERIE 70/90 SINISTRA, CON STESSO PROFILO LINEA FRONTALE**

**EN** Head 2 sides S70/90 left, with the same front line profile • **DE** Abschluss element seiten S70/90 links, mit dem gleichen Frontlinienprofil • **FR** Element de jonction 2 cotés S70/90 gauche, avec le même profil de ligne • **ES** Embellecedor 2 lados S70/90 izquierda, con el mismo perfil de línea frontal  
**cm. 7,5x160,5**



**1.280,00**  
30 / 1,00

**TMTA-79DX**  
08547920

**TESTATA TAMBURATA 2 LATI SERIE 70/90 DESTRA, CON STESSO PROFILO LINEA FRONTALE**

**EN** Head 2 sides S70/90 right, with the same front line profile • **DE** Abschluss element seiten S70/90 recht, mit dem gleichen Frontlinienprofil • **FR** Element de jonction 2 cotés S70/90 droit, avec le même profil de ligne • **ES** Embellecedor 2 lados S70/90 derecha, con el mismo perfil de línea frontal  
**cm. 7,5x160,5**



**1.280,00**  
30 / 1,00

# ACCESSORI

MOD. COD.	DESCRIZIONE/DESCRIPTION/BEZEICHNUNG/DESCRIPTION/DESCRIPCIÓN DIMENSIONI/DIMENSIONS/ABMESSUNGEN/DIMENSIONS/DIMENSIONES	POTENZA/POWER/LEISTUNG/PUISSANCE/POTENCIA VOLTAGGIO/VOLTAGE/SPANNUNG/VOLTAGE/VOLTAJE	↓ kW kcal/h	↗ kw V~ Hz	PREZZO/PRICE € PREIS/PRIX/PRECIO € KG / M <sup>3</sup>
<b>TSP-4</b> 18400400	<b>COPPIA TRAVERSE SUPPORTO PONTE</b> EN Support for bridge type system • DE Bruckengestell • FR Support en pont cm. 40x 6x 6				<b>172,00</b> / 0,01
<b>TSP-6</b> 18400600	cm. 60x 6x 6				<b>194,00</b> / 0,01
<b>TSP-8</b> 18400800	cm. 80x 6x 6				<b>217,00</b> / 0,01
<b>TSP-10</b> 18401000	cm. 100x 6x 6				<b>241,00</b> / 0,02
<b>TSP-12</b> 18401200	cm. 120x 6x 6				<b>262,00</b> / 0,02
<b>TSP-14</b> 18401400	cm. 140x 6x 6				<b>285,00</b> / 0,02
<b>TSP-16</b> 18401600	cm. 160x 6x 6				<b>303,00</b> / 0,03
<b>TSP-18</b> 18401800	cm. 180x 6x 6				<b>331,00</b> / 0,03
<b>TSP-20</b> 18402000	cm. 200x 6x 6				<b>348,00</b> / 0,03
<b>09610800</b>	<b>MITRA 800</b> EN Chimney jack 800 • DE Lüftungsaufsatz 800 • FR Mitre 800 • ES Caperuza 800 cm. 80x 7x 92h				<b>467,00</b> 16 / 0,04
<b>09611200</b>	<b>MITRA 1200</b> EN Chimney jack 1200 • DE Lüftungsaufsatz 1200 • FR Mitre 1200 • ES Caperuza 1200 cm. 120x 7x 92h				<b>625,00</b> 24 / 0,06
<b>08610802</b>	<b>MITRA 800 PER F45-78G</b> EN Chimney jack 800 • DE Lüftungsaufsatz 800 • FR Mitre 800 • ES Caperuza 800 cm. 80x 7x 52h				<b>467,00</b> 16 / 0,04
<b>09610801</b>	<b>CAMINO ANTIVENTO 800</b> EN Draught diverter 800 • DE Strömungssicherung 800 • FR Cheminee anti-vent 800 • ES Chimenea contra viento 800 cm. 80x 19x 120h				<b>657,00</b> 16 / 0,15
<b>09611201</b>	<b>CAMINO ANTIVENTO 1200</b> EN Draught diverter 1200 • DE Strömungssicherung 1200 • FR Cheminee anti-vent 1200 • ES Chimenea contra viento 1200 cm. 120x 19x 120h				<b>867,00</b> 24 / 0,25
<b>08610803</b>	<b>CAMINO ANTIVENTO 800 PER F45-78G</b> EN Draught diverter 800 for F45-78G • DE Strömungssicherung 800 für F45-78G • FR Cheminee anti-vent 800 pour F45-78G • ES Chimenea contra viento 800 para F45-78G cm. 80x 19x 77h				<b>657,00</b> 16 / 0,15

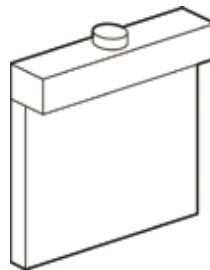
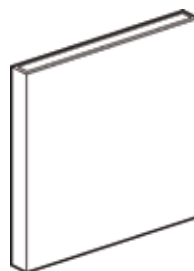
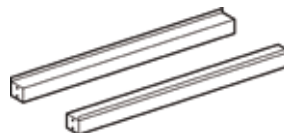



# ACCESSORI

MOD. COD.	DESCRIZIONE/DESCRIPTION/BEZEICHNUNG/DESCRIPTION/DESCRIPCIÓN DIMENSIONI/DIMENSIONS/ABMESSUNGEN/DIMENSIONS/DIMENSIONES	POTENZA/POWER/LEISTUNG/PUISSANCE/POTENCIA VOLTAGGIO/VOLTAGE/SPANNUNG/VOLTAGE/VOLTAJE	$\frac{kW}{kcal/h}$ $\frac{kw}{V\sim}$ Hz	PREZZO/PRICE € PREIS/PRIX/PRECIO € KG / M <sup>3</sup>
08570103	<b>MENSOLA ANTERIORE</b> EN Earlier shelf • DE Frühere Regal • FR Plus tôt plateau • ES A principios de la plataforma cm. 30x 21x 5h			<b>324,00</b> / 0,01
08570104	cm. 40x 21x 5h			<b>333,00</b> / 0,01
08570105	cm. 50x 21x 5h			<b>343,00</b> / 0,01
08570106	cm. 60x 21x 5h			<b>352,00</b> / 0,01
08570107	cm. 70x 21x 5h			<b>361,00</b> / 0,01
08570108	cm. 80x 21x 5h			<b>369,00</b> / 0,01
08570109	cm. 90x 21x 5h			<b>380,00</b> / 0,02
08570110	cm. 100x 21x 5h			<b>389,00</b> / 0,02
08570111	cm. 110x 21x 5h			<b>400,00</b> / 0,02
08570112	cm. 120x 21x 5h			<b>410,00</b> / 0,02
08570113	cm. 130x 21x 5h			<b>424,00</b> / 0,02
08570114	cm. 140x 21x 5h			<b>433,00</b> / 0,02
08570115	cm. 150x 21x 5h			<b>447,00</b> / 0,02
08570116	cm. 160x 21x 5h			<b>460,00</b> / 0,03

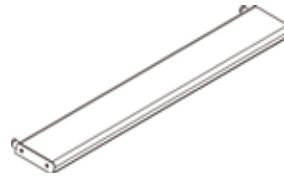

# ACCESSORI

MOD. COD.	DESCRIZIONE/DESCRIPTION/BEZEICHNUNG/DESCRIPTION/DESCRIPCIÓN DIMENSIONI/DIMENSIONS/ABMESSUNGEN/DIMENSIONS/DIMENSIONES	POTENZA/POWER/LEISTUNG/PUISSANCE/POTENCIA VOLTAGGIO/VOLTAGE/SPANNUNG/VOLTAGE/VOLTAJE	$\frac{kW}{kcal/h}$ $\frac{V}{Hz}$	PREZZO/PRICE PREIS/PRIX/PRECIO € KG / M <sup>3</sup>
08570002	<b>CORRIMANO</b> <b>EN</b> HANDRAIL • <b>DE</b> HAND LAUF • <b>FR</b> MAIN COURANTE • <b>ES</b> PASAMANO cm. <b>20x 7x 4h</b>			<b>271,00</b> / 0,00
08570003	cm. <b>30x 7x 4h</b>			<b>276,00</b> / 0,00
08570004	cm. <b>40x 7x 4h</b>			<b>279,00</b> / 0,00
08570005	cm. <b>50x 7x 4h</b>			<b>287,00</b> / 0,00
08570006	cm. <b>60x 7x 4h</b>			<b>295,00</b> / 0,00
08570007	cm. <b>70x 7x 4h</b>			<b>301,00</b> / 0,00
08570008	cm. <b>80x 7x 4h</b>			<b>306,00</b> / 0,01
08570009	cm. <b>90x 7x 4h</b>			<b>310,00</b> / 0,01
08570010	cm. <b>100x 7x 4h</b>			<b>315,00</b> / 0,01
08570011	cm. <b>110x 7x 4h</b>			<b>324,00</b> / 0,01
08570012	cm. <b>120x 7x 4h</b>			<b>333,00</b> / 0,01
08570013	cm. <b>130x 7x 4h</b>			<b>344,00</b> / 0,01
08570014	cm. <b>140x 7x 4h</b>			<b>356,00</b> / 0,01
08570015	cm. <b>150x 7x 4h</b>			<b>388,00</b> / 0,01
08570016	cm. <b>160x 7x 4h</b>			<b>420,00</b> / 0,01



**533116300 GIUNZIONE CORRIMANO**  
**EN** junction handrail • **DE** Gelenk Hand lauf • **FR**  
Main courante de l'embranchement • **ES** conexión  
pasamano  
cm.  $\emptyset$  **3x 2,4**



**43,00**  
/ 1,00

MOD. \_\_\_\_\_  
COD. \_\_\_\_\_

DESCRIZIONE/DESCRIPTION/BEZEICHNUNG/DESCRIPTION/DESCRIPCIÓN  
DIMENSIONI/DIMENSIONS/ABMESSUNGEN/DIMENSIONS/DIMENSIONES

POTENZA/POWER/LEISTUNG/PUISSANCE/POTENCIA  
VOLTAGGIO/VOLTAGE/SPANNUNG/VOLTAGE/VOLTAJE

⚡ kW kcal/h  
⚡ kW V~ Hz

PREZZO/PRICE €  
PREIS/PRIX/PRECIO €  
KG / M<sup>3</sup>

**ZB**  
01410000

**ZOCCOLATURA BASE**  
**EN** FRONT PLINTH • **DE** GRUNDSOCKEL • **FR**  
PLINTHE FRONTAL • **ES** ZOCOLOS BASE  
€/m x cm. 15h

**113,00**  
/

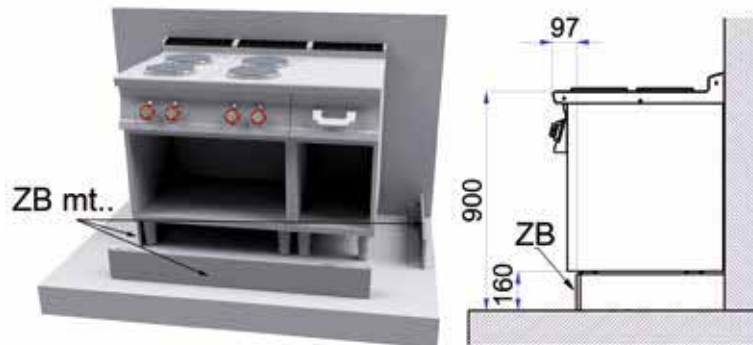

**FZ-7**  
08480001

**ZOCCOLATURA LATERALE - KIT**  
**EN** side plinth - kit • **DE** seitensockel - kit • **FR** plinthe  
lateral - kit • **ES** zocolos lateral - kit  
cm. 1,5x 61x 6h

**234,00**  
/ 0,02



**CZ-72/92**  
08480002

**KIT CASSETTO ZOCCOLO, INCLUSI 4 PIEDINI**  
**EN** drawer clog - kit (4 small feet included) • **DE**  
schubladen sockel - kit (4 kleine FüÙe enthalten) • **FR**  
tiroir plinthe - kit (4 petits pieds inclus) • **ES** cajon  
zocolos - kit (4 pies pequeno incluido)  
cm. 20x 61x 5,5h

**137,00**  
3 / 0,01



**CZ-73**  
08480003

cm. 30x 61x 5,5h

**159,00**  
3.5 / 0,02

**CZ-74**  
08480004

cm. 40x 61x 5,5h

**183,00**  
4 / 0,02

**CZ-76**  
08480006

cm. 60x 61x 5,5h

**241,00**  
5 / 0,03

**CZ-78**  
08480008

cm. 80x 61x 5,5h

**302,00**  
7 / 0,04

**CZ-712**  
08480012

cm. 120x 61x 5,5h

**422,00**  
8 / 0,06

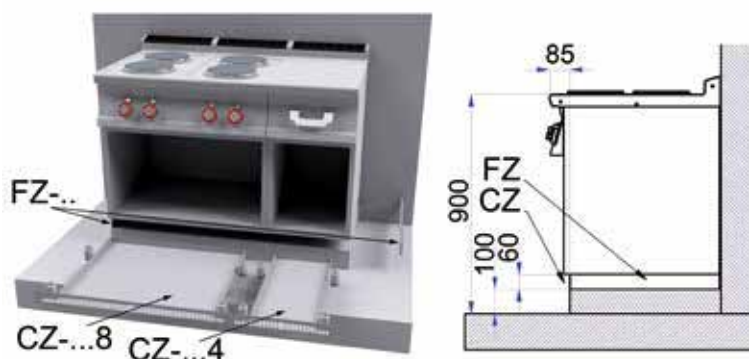

# PIANI LAVORO - TOP

MOD. \_\_\_\_\_  
COD. \_\_\_\_\_

DESCRIZIONE/DESCRIPTION/BEZEICHNUNG/DESCRIPTION/DESCRIPCIÓN  
DIMENSIONI/DIMENSIONS/ABMESSUNGEN/DIMENSIONS/DIMENSIONES

POTENZA/POWER/LEISTUNG/PUISSANCE/POTENCIA  
VOLTAGGIO/VOLTAGE/SPANNUNG/VOLTAGE/VOLTAJE

⚡ kcal/h ⚡ kw  
V~ Hz

PREZZO/PRICE €  
PREIS/PRIX/PRECIO €  
KG / M<sup>3</sup>

**PLT-72**  
18010200

**PIANO LAVORO (INCLUSA 1 TESTATA CHIUSURA PIANO MOD.TPA-7)**  
**EN** Worktop (included 1 Head end filler strip mod.TPA-7) • **DE** Arbeitsplatte (inbegriffen 1 Abschluss-Element mod.TPA-7) • **FR** Plan de travail (inclus 1 Élément de jonction top mod.TPA-7) • **ES** Sobre de trabajo (incluida 1 Chapa de cierre para top mod.TPA-7)  
**cm. 20x 70,5x 28h**



**432,00**  
15 / 0,18

**PLST-73**  
18010301

**cm. 30x 70,5x 28h**



**462,00**  
20 / 0,18

**PLST-74**  
18010401

**cm. 40x 70,5x 28h**



**473,00**  
22 / 0,18

**PLST-76**  
18010601

**cm. 60x 70,5x 28h**



**617,00**  
27 / 0,26

**PLST-78**  
18010801

**cm. 80x 70,5x 28h**



**703,00**  
33 / 0,35

**PLT-73**  
18010300

**PIANO LAVORO CASSETTO CON 1 BACINELLA: CM. 19X50X15H INOX (INCLUSA 1 TESTATA CHIUSURA PIANO MOD.TPA-7)**  
**EN** Worktop Drawer with 1 container: cm. 19x50x15h inox (included 1 Head end filler strip mod.TPA-7) • **DE** Arbeitsplatte Schublade mit 1 Behälter: cm. 19x50x15h inox (inbegriffen 1 Abschluss-Element mod.TPA-7) • **FR** Plan de travail Tiroir avec 1 bac: cm. 19x50x15h inox (inclus 1 Élément de jonction top mod.TPA-7) • **ES** Sobre de trabajo Cajón con 1 contenedore: cm. 19x50x15h inox (incluida 1 Chapa de cierre para top mod.TPA-7)  
**cm. 30x 70,5x 28h**



**662,00**  
23 / 0,18

MOD. \_\_\_\_\_  
COD. \_\_\_\_\_

DESCRIZIONE/DESCRIPTION/BEZEICHNUNG/DESCRIPTION/DESCRIPCIÓN  
DIMENSIONI/DIMENSIONS/ABMESSUNGEN/DIMENSIONS/DIMENSIONES

POTENZA/POWER/LEISTUNG/PUISSANCE/POTENCIA  
VOLTAGGIO/VOLTAGE/SPANNUNG/VOLTAGE/VOLTAJE

⚡ kW kcal/h  
⚡ kw V~ Hz

PREZZO/PRICE €  
PREIS/PRIX/PRECIO €  
KG / M<sup>3</sup>

**PLT-74**  
18010400

**PIANO LAVORO CASSETTO CON 1 BACINELLA GN 1/1 15H PLASTICA (INCLUSA 1 TESTATA CHIUSURA PIANO MOD.TPA-7)**

**EN** Worktop - Drawer with 1 plastic container GN 1/1 15h (included 1 Head end filler strip mod.TPA-7) • **DE** Arbeitsplatte - Schublade mit 1 GN 1/1 15h Kunststoffbehälter (inbegriffen 1 Abschluss-Element mod.TPA-7) • **FR** Plan de travail - Tiroir avec bac en plastique GN 1/1 15h (inclus 1 Élément de jonction top mod.TPA-7) • **ES** Sobre de trabajo Cajón con 1 contenedor GN 1/1 15h plástico (incluida 1 Chapa de cierre para top mod.TPA-7)  
**cm. 40x 70,5x 28h**



**669,00**  
26 / 0,18

**PLT-76**  
18010600

**PIANO LAVORO CASSETTO CON 1 BACINELLA: CM. 49X50X15H INOX (INCLUSA 1 TESTATA CHIUSURA PIANO MOD.TPA-7)**

**EN** Worktop Drawer with 1 container: cm. 49x50x15h inox (included 1 Head end filler strip mod.TPA-7) • **DE** Arbeitsplatte Schublade mit 1 Behälter: cm. 49x50x15h inox (inbegriffen 1 Abschluss-Element mod.TPA-7) • **FR** Plan de travail Tiroir avec 1 bac: cm. 49x50x15h inox (inclus 1 Élément de jonction top mod.TPA-7) • **ES** Sobre de trabajo Cajón con 1 contenedore: cm. 49x50x15h inox (incluida 1 Chapa de cierre para top mod.TPA-7)  
**cm. 60x 70,5x 28h**



**834,00**  
36 / 0,26

**PLT-78**  
18010800

**PIANO LAVORO CASSETTO CON 2 BACINELLE GN 1/1 15H PLASTICA (INCLUSA 1 TESTATA CHIUSURA PIANO MOD.TPA-7)**

**EN** Worktop - Drawer with 2 plastic containers GN 1/1 15h (included 1 Head end filler strip mod.TPA-7) • **DE** Arbeitsplatte - Schublade mit 2 GN 1/1 15h Kunststoffbehältern (inbegriffen 1 Abschluss-Element mod.TPA-7) • **FR** Plan de travail - Tiroir avec 2 bacs en plastique GN 1/1 15h (inclus 1 Élément de jonction top mod.TPA-7) • **ES** Sobre de trabajo Cajón con 2 contenedores GN 1/1 15h plástico (incluida 1 Chapa de cierre para top mod.TPA-7)  
**cm. 80x 70,5x 28h**



**942,00**  
43 / 0,35

**LAT-74**  
18020400

**LAVELLO RUBINETTO A LEVA - VASCA CM. 30X35X15H (INCLUSA 1 TESTATA CHIUSURA PIANO MOD.TPA-7)**

**EN** Sink unit - Lever type tap - Bowl cm. 30x35x15h (included 1 Head end filler strip mod.TPA-7) • **DE** Spülbecken - Einhebel-Mischbatterie Becken cm. 30x35x15h (inbegriffen 1 Abschluss-Element mod.TPA-7) • **FR** Bac-évier avec robinetterie - Bac cm 30x35x15h (inclus 1 Élément de jonction top mod.TPA-7) • **ES** Fregadero - Grifo a palanca - Pileta cm. 30x35x15h (incluida 1 Chapa de cierre para top mod.TPA-7)  
**cm. 40x 70,5x 28h**



**856,00**  
22 / 0,18

**PCT-74ET**  
18030430

**PIANO COTTURA TRIFASE - N. 2 PIASTRE (INCLUSA 1 TESTATA CHIUSURA PIANO MOD.TPA-7)**

**EN** Boiling unit threephase - N. 2 plates (included 1 Head end filler strip mod.TPA-7) • **DE** Kochplatte dreiphasig - N. 2 Kochplatten (inbegriffen 1 Abschluss-Element mod.TPA-7) • **FR** Rechaud électriques - N. 2 plaques (inclus 1 Élément de jonction top mod.TPA-7) • **ES** Sobre de cocción trifásico - N. 2 planchas (incluida 1 Chapa de cierre para top mod.TPA-7)  
**cm. 40x 70,5x 28h**



⚡ 5,2 kW  
400V~2N  
230V~3  
230V~  
50/60 Hz

**722,00**  
26 / 0,18

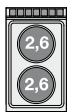



# PIANI COTTURA ELETTRICI - TOP

MOD. \_\_\_\_\_  
COD. \_\_\_\_\_

DESCRIZIONE/DESCRIPTION/BEZEICHNUNG/DESCRIPTION/DESCRIPCIÓN  
DIMENSIONI/DIMENSIONS/ABMESSUNGEN/DIMENSIONS/DIMENSIONES

POTENZA/POWER/LEISTUNG/PUISSANCE/POTENCIA  
VOLTAGGIO/VOLTAGE/SPANNUNG/VOLTAGE/VOLTAJE

⚡ kW \_\_\_\_\_  
kcal/h \_\_\_\_\_  
V~ \_\_\_\_\_  
Hz \_\_\_\_\_

PREZZO/PRICE € \_\_\_\_\_  
PREIS/PRIX/PRECIO € \_\_\_\_\_  
KG / M<sup>3</sup> \_\_\_\_\_

**PCT-78ET**  
18030830

**PIANO COTTURA TRIFASE N. 4 PIASTRE (INCLUSA 1 TESTATA CHIUSURA PIANO MOD. TPA-7)**

**EN** Boiling unit threephase - N. 4 plates (included 1 Head end filler strip mod.TPA-7) • **DE** Kochplatte dreiphasig - N. 4 Kochplatten (inbegriffen 1 Abschluss-Element mod.TPA-7) • **FR** Rechaud électriques - N. 4 plaques (inclus 1 Élément de jonction top mod.TPA-7) • **ES** Sobre de cocción trifásico - N. 4 planchas (incluida 1 Chapa de cierre para top mod.TPA-7)  
**cm. 80x 70,5x 28h**



⚡ 10,4 kW \_\_\_\_\_ **1.142,00**  
400V~3N \_\_\_\_\_ 63 / 0,35  
230V~3 \_\_\_\_\_  
50/60 Hz \_\_\_\_\_

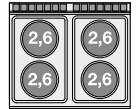

**PCT-712ET**  
18031230

**PIANO COTTURA TRIFASE N. 6 PIASTRE (INCLUSA 1 TESTATA CHIUSURA PIANO MOD. TPA-7)**

**EN** Boiling unit threephase - N. 6 plates (included 1 Head end filler strip mod.TPA-7) • **DE** Kochplatte dreiphasig - N. 6 Kochplatten (inbegriffen 1 Abschluss-Element mod.TPA-7) • **FR** Rechaud électriques - N. 6 plaques (inclus 1 Élément de jonction top mod.TPA-7) • **ES** Sobre de cocción trifásico - N. 6 planchas (incluida 1 Chapa de cierre para top mod.TPA-7)  
**cm. 120x 70,5x 28h**



⚡ 15,6 kW \_\_\_\_\_ **1.825,00**  
400V~3N \_\_\_\_\_ 82 / 0,51  
230V~3 \_\_\_\_\_  
50/60 Hz \_\_\_\_\_

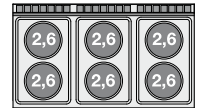

**PCQT-74ET**  
18030431

**PIANO COTTURA TRIFASE - N. 2 PIASTRE QUADRE (INCLUSA 1 TESTATA CHIUSURA PIANO MOD.TPA-7)**

**EN** Boiling unit threephase - N. 2 square plates (included 1 Head end filler strip mod.TPA-7) • **DE** Kochplatte dreiphasig - N. 2 quadratischen Platten (inbegriffen 1 Abschluss-Element mod.TPA-7) • **FR** Rechaud électriques - N. 2 plaques carrés (inclus 1 Élément de jonction top mod.TPA-7) • **ES** Sobre de cocción trifásico - N. 2 planchas cuadradas (incluida 1 Chapa de cierre para top mod.TPA-7)  
**cm. 40x 70,5x 28h**



⚡ 5,2 kW \_\_\_\_\_ **1.242,00**  
400V~2N \_\_\_\_\_ 30 / 0,18  
230V~3 \_\_\_\_\_  
50/60 Hz \_\_\_\_\_

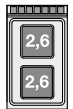

**PCQT-78ET**  
18030831

**PIANO COTTURA TRIFASE - N. 4 PIASTRE QUADRE (INCLUSA 1 TESTATA CHIUSURA PIANO MOD.TPA-7)**

**EN** Boiling unit threephase - N. 4 square plates (included 1 Head end filler strip mod.TPA-7) • **DE** Kochplatte dreiphasig - N. 4 quadratischen Platten (inbegriffen 1 Abschluss-Element mod.TPA-7) • **FR** Rechaud électriques - N. 4 plaques carrés (inclus 1 Élément de jonction top mod.TPA-7) • **ES** Sobre de cocción trifásico - N. 4 planchas cuadradas (incluida 1 Chapa de cierre para top mod.TPA-7)  
**cm. 80x 70,5x 28h**



⚡ 10,4 kW \_\_\_\_\_ **2.121,00**  
400V~3N \_\_\_\_\_ 66 / 0,35  
230V~3 \_\_\_\_\_  
50/60 Hz \_\_\_\_\_



**PCQT-712ET**  
18031231

**PIANO COTTURA TRIFASE - N. 6 PIASTRE QUADRE (INCLUSA 1 TESTATA CHIUSURA PIANO MOD.TPA-7)**

**EN** Boiling unit threephase - N. 6 square plates (included 1 Head end filler strip mod.TPA-7) • **DE** Kochplatte dreiphasig - N. 6 quadratischen Platten (inbegriffen 1 Abschluss-Element mod.TPA-7) • **FR** Rechaud électriques - N. 6 plaques carrés (inclus 1 Élément de jonction top mod.TPA-7) • **ES** Sobre de cocción trifásico - N. 6 planchas cuadradas (incluida 1 Chapa de cierre para top mod.TPA-7)  
**cm. 120x 70,5x 28h**



⚡ 15,6 kW \_\_\_\_\_ **3.289,00**  
400V~3N \_\_\_\_\_ 97 / 0,51  
230V~3 \_\_\_\_\_  
50/60 Hz \_\_\_\_\_

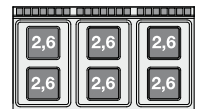

# PIANI COTTURA ELETTRICI - TOP

MOD. \_\_\_\_\_  
COD. \_\_\_\_\_

DESCRIZIONE/DESCRIPTION/BEZEICHNUNG/DESCRIPTION/DESCRIPCIÓN  
DIMENSIONI/DIMENSIONS/ABMESSUNGEN/DIMENSIONS/DIMENSIONES

POTENZA/POWER/LEISTUNG/PUISSANCE/POTENCIA  
VOLTAGGIO/VOLTAGE/SPANNUNG/VOLTAGE/VOLTAJE

⚡ kW \_\_\_\_\_  
kcal/h \_\_\_\_\_  
V~ \_\_\_\_\_  
Hz \_\_\_\_\_

PREZZO/PRICE € \_\_\_\_\_  
PREIS/PRIX/PRECIO € \_\_\_\_\_  
KG / M<sup>3</sup> \_\_\_\_\_

**PCCT-74ET**  
18030432

**PIANO COTTURA VETROCERAMICA TRIFASE**  
**- N. 2 ZONE - VETRO CM.35X57 (INCLUSA 1 TESTATA CHIUSURA PIANO MOD.TPA-7)**  
**EN** Ceramic glass boiling unit - n. 2 zones - glass cm.35x57 (included 1 Head end filler strip mod.TPA-7)  
• **DE** Ceran-Kochplatte dreiphasig - 2 zonen - Glas 35x57 cm (inbegriffen 1 Abschluss-Element mod. TPA-7) • **FR** Plan de cuisson à vitroceramique triphasé N. 2 zones - Verre cm.35x57 (inclus 1 Elément de jonction top mod.TPA-7) • **ES** Sobre de cocción trifásico vitrocerámica - 2 zonas - vidrio cm.35x57 (incluida 1 Chapa de cierre para top mod.TPA-7)  
**cm. 40x 70,5x 28h**

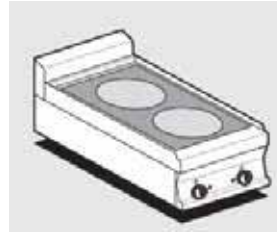

⚡ 5 kW \_\_\_\_\_ **1.545,00**  
400V~2N \_\_\_\_\_ 35 / 0,18  
230V~3  
230V~  
50/60 Hz

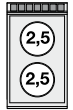

**PCCT-78ET**  
18030832

**PIANO COTTURA VETROCERAMICA TRIFASE**  
**- N. 4 ZONE - VETRO CM.75X57 (INCLUSA 1 TESTATA CHIUSURA PIANO MOD.TPA-7)**  
**EN** Ceramic glass boiling unit - n. 4 zones - glass cm.75x57 (included 1 Head end filler strip mod.TPA-7)  
• **DE** Ceran-Kochplatte dreiphasig - 4 zonen - Glas 75x57 cm (inbegriffen 1 Abschluss-Element mod. TPA-7) • **FR** Plan de cuisson à vitroceramique triphasé N. 4 zones - Verre cm.75x57 (inclus 1 Elément de jonction top mod.TPA-7) • **ES** Sobre de cocción trifásico vitrocerámica - 4 zonas - vidrio cm.75x57 (incluida 1 Chapa de cierre para top mod.TPA-7)  
**cm. 80x 70,5x 28h**



⚡ 10 kW \_\_\_\_\_ **2.343,00**  
400V~3N \_\_\_\_\_ 62 / 0,35  
230V~3  
50/60 Hz

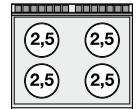

**PCIT-74ET**  
18030433

**PIANO COTTURA INDUZIONE TRIFASE**  
**- N. 2 ZONE - VETRO CM.35X57 (NON POSIZIONARE SU FORNI O CASSETTIERE) (INCLUSA 1 TESTATA CHIUSURA PIANO MOD. TPA-7)**  
**EN** Three-phase induction cooking - 2 zones - glass cm.35x57 (do not place on ovens or drawers) (included 1 Head end filler strip mod.TPA-7) • **DE** Induktions-Kochplatte dreiphasig - 2 zonen - Glas 35x57 cm (nicht Platz auf Öfen oder Schubladen) (inbegriffen 1 Abschluss-Element mod.TPA-7) • **FR** Plan de cuisson à induction triphasé N. 2 zones - Verre cm.35x57 (ne placez pas sur des fours ou des tiroirs) (inclus 1 Elément de jonction top mod.TPA-7) • **ES** Encimera inducción trifásica - 2 zonas - Vidrio cm.35x57 (No coloque en los hornos o en los cajones) (incluida 1 Chapa de cierre para top mod.TPA-7)  
**cm. 40x 70,5x 28h**



⚡ 10 kW \_\_\_\_\_ **6.691,00**  
400V~3 \_\_\_\_\_ 34 / 0,18  
50/60 Hz

**PCIT-74ETD**  
18030438

**PIANO COTTURA INDUZIONE TRIFASE**  
**- N. 2 ZONE - VETRO CM.35X57 (NON POSIZIONARE SU FORNI O CASSETTIERE) - COMANDI DIGITALI (INCLUSA 1 TESTATA CHIUSURA PIANO MOD.TPA-7)**  
**EN** Three-phase induction cooking - 2 zones - glass cm.35x57 (do not place on ovens or drawers) - digital controls (included 1 Head end filler strip mod.TPA-7) • **DE** Induktions-Kochplatte dreiphasig - 2 zonen - Glas 35x57 cm (nicht Platz auf Öfen oder Schubladen) - digitale Steuerungen (inbegriffen 1 Abschluss-Element mod.TPA-7) • **FR** Plan de cuisson à induction triphasé N. 2 zones - Verre cm.35x57 (ne placez pas sur des fours ou des tiroirs) - commandes numériques (inclus 1 Elément de jonction top mod.TPA-7) • **ES** Encimera inducción trifásica - 2 zonas - Vidrio cm.35x57 (No coloque en los hornos o en los cajones) - controles digitales (incluida 1 Chapa de cierre para top mod. TPA-7)  
**cm. 40x 70,5x 28h**



⚡ 10 kW \_\_\_\_\_ **7.181,00**  
400V~3 \_\_\_\_\_ 34 / 0,18  
50/60 Hz



Le immagini presentate non sono vincolanti. La ditta si riserva di apportare modifiche senza preavviso. • The pictures are purely representative. The manufacturer reserves the right to modify the technical data and models without previous notice. • Les images

LO

présentées ne nous engagent pas. La Société se réserve le droit d'apporter tout modification sans préavis. • Die dargestellten Abbildungen sind nicht verbindlich. Technische Änderungen vorbehalten. • Las imágenes presentadas no son vinculantes. El Fabricante se reserva el derecho de modificar sus productos sin previo aviso.

01/20

195

# PIANI COTTURA A INDUZIONE - TOP

MOD. \_\_\_\_\_  
COD. \_\_\_\_\_

DESCRIZIONE/DESCRIPTION/BEZEICHNUNG/DESCRIPTION/DESCRIPCIÓN  
DIMENSIONI/DIMENSIONS/ABMESSUNGEN/DIMENSIONS/DIMENSIONES

POTENZA/POWER/LEISTUNG/PUISSANCE/POTENCIA  
VOLTAGGIO/VOLTAGE/SPANNUNG/VOLTAGE/VOLTAJE

⚡ kW \_\_\_\_\_  
400V~3 \_\_\_\_\_  
50/60 Hz \_\_\_\_\_

PREZZO/PRICE € \_\_\_\_\_  
PREIS/PRIX/PRECIO \_\_\_\_\_  
KG / M<sup>3</sup> \_\_\_\_\_

**PCIWT-74ET** PIANO COTTURA INDUZIONE TRIFASE "WOK"  
18030434 - N. 1 ZONA - VETRO Ø 30 CM. (NON  
POSIZIONARE SU FORNI O CASSETTIERE)  
(INCLUSA 1 TESTATA CHIUSURA PIANO MOD.  
TPA-7)

**EN** Three-phase induction cooking "WOK" - 1 zone  
- glass Ø 30 cm (do not place on ovens or drawers)  
(included 1 Head end filler strip mod.TPA-7) • **DE**  
Induktions-Kochplatte "WOK" dreiphasig - 1 zonen -  
Glas Ø 30 cm (nicht Platz auf Öfen oder  
Schubladen) (inbegriffen 1 Abschluss-Element mod.TPA-7) • **FR**  
Plan de cuisson à induction "WOK" triphasé N. 1  
zone - Verre cm Ø 30 (ne placez pas sur des fours  
ou des tiroirs) (inclus 1 Élément de jonction top mod.  
TPA-7) • **ES** Encimera inducción "WOK" trifásica - 1  
zona - Vidrio Ø 30 cm (No coloque en los hornos o en  
los cajones) (incluida 1 Chapa de cierre para top mod.  
TPA-7)  
**cm. 40x 70,5x 28h**



⚡ 5 kW \_\_\_\_\_ **5.032,00**  
400V~3 \_\_\_\_\_ 32 / 0,18  
50/60 Hz \_\_\_\_\_

**PCIWT-74ETD** PIANO COTTURA INDUZIONE TRIFASE "WOK"  
18030439 - N. 1 ZONA - VETRO Ø 30 CM. (NON  
POSIZIONARE SU FORNI O CASSETTIERE)  
- COMANDI DIGITALI (INCLUSA 1 TESTATA  
CHIUSURA PIANO MOD.TPA-7)

**EN** Three-phase induction cooking "WOK" - 1 zone  
- glass Ø 30 cm (do not place on ovens or drawers)  
- digital controls (included 1 Head end filler strip mod.  
TPA-7) • **DE** Induktions-Kochplatte "WOK" dreiphasig  
- 1 zonen - Glas Ø 30 cm (nicht Platz auf Öfen oder  
Schubladen) - digitale Steuerungen (inbegriffen 1  
Abschluss-Element mod.TPA-7) • **FR** Plan de cuisson à  
induction "WOK" triphasé N. 1 zone - Verre cm Ø 30  
(ne placez pas sur des fours ou des tiroirs) - commandes  
numériques (inclus 1 Élément de jonction top mod.TPA-7)  
• **ES** Encimera inducción "WOK" trifásica - 1 zona  
- Vidrio Ø 30 cm (No coloque en los hornos o en los  
cajones) - controles digitales (incluida 1 Chapa de cierre  
para top mod.TPA-7)  
**cm. 40x 70,5x 28h**



⚡ 5 kW \_\_\_\_\_ **5.277,00**  
400V~3 \_\_\_\_\_ 32 / 0,18  
50/60 Hz \_\_\_\_\_

**PCIT-78ET** PIANO COTTURA INDUZIONE TRIFASE  
18030833 - N. 4 ZONE - VETRO CM.75X57 (NON  
POSIZIONARE SU FORNI O CASSETTIERE)  
(INCLUSA 1 TESTATA CHIUSURA PIANO MOD.  
TPA-7)

**EN** Three-phase induction cooking - 4 zones - glass  
cm.75x57 (do not place on ovens or drawers) (included  
1 Head end filler strip mod.TPA-7) • **DE** Induktions-  
Kochplatte dreiphasig - 4 zonen - Glas 75x57 cm  
(nicht Platz auf Öfen oder Schubladen) (inbegriffen 1  
Abschluss-Element mod.TPA-7) • **FR** Plan de cuisson  
à induction triphasé N. 4 zones - Verre cm.75x57 (ne  
placez pas sur des fours ou des tiroirs) (inclus 1 Élément  
de jonction top mod.TPA-7) • **ES** Encimera inducción  
trifásica - 4 zonas - Vidrio cm.75x57 (No coloque en  
los hornos o en los cajones) (incluida 1 Chapa de cierre  
para top mod.TPA-7)  
**cm. 80x 70,5x 28h**



⚡ 20 kW \_\_\_\_\_ **12.532,00**  
400V~3 \_\_\_\_\_ 66 / 0,35  
50/60 Hz \_\_\_\_\_

# PIANI COTTURA A INDUZIONE - TOP

MOD. \_\_\_\_\_  
COD. \_\_\_\_\_

DESCRIZIONE/DESCRIPTION/BEZEICHNUNG/DESCRIPTION/DESCRIPCIÓN  
DIMENSIONI/DIMENSIONS/ABMESSUNGEN/DIMENSIONS/DIMENSIONES

POTENZA/POWER/LEISTUNG/PUISSANCE/POTENCIA  
VOLTAGGIO/VOLTAGE/SPANNUNG/VOLTAGE/VOLTAJE

⚡ kW \_\_\_\_\_  
kcal/h \_\_\_\_\_  
V~ \_\_\_\_\_  
Hz \_\_\_\_\_

PREZZO/PRICE € \_\_\_\_\_  
PREIS/PRIX/PRECIO € \_\_\_\_\_  
KG / M<sup>3</sup> \_\_\_\_\_

**PCT-78ETD**  
18030838

**PIANO COTTURA INDUZIONE TRIFASE**  
- **N. 4 ZONE - VETRO CM.75X57 (NON**  
**POSIZIONARE SU FORNI O CASSETTIERE)**  
**- COMANDI DIGITALI (INCLUSA 1 TESTATA**  
**CHIUSURA PIANO MOD.TPA-7)**

**EN** Three-phase induction cooking - 4 zones - glass cm.75x57 (do not place on ovens or drawers) - digital controls (included 1 Head end filler strip mod.TPA-7) • **DE** Induktions-Kochplatte dreiphasig - 4 zonen - Glas 75x57 cm (nicht Platz auf Öfen oder Schubladen) - digitale Steuerungen (inbegriffen 1 Abschluss-Element mod.TPA-7) • **FR** Plan de cuisson à induction triphasé N. 4 zones - Verre cm.75x57 (ne placez pas sur des fours ou des tiroirs) - commandes numériques (inclus 1 Élément de jonction top mod.TPA-7) • **ES** Encimera inducción trifásica - 4 zonas - Vidrio cm.75x57 (No coloque en los hornos o en los cajones) - controles digitales (incluida 1 Chapa de cierre para top mod.TPA-7)

**cm. 80x 70,5x 28h**



⚡ 20 kW \_\_\_\_\_ **13.512,00**  
400V~3 \_\_\_\_\_ 66 / 0,35  
50/60 Hz \_\_\_\_\_

**PCT-74GP**  
18210450

**PIANO COTTURA GAS 2 FUOCHI (INCLUSA 1**  
**TESTATA CHIUSURA PIANO MOD.TPA-7)**

**EN** Gas heated boiling unit - 2 burners (included 1 Head end filler strip mod.TPA-7) • **DE** Gas-kochplatte - 2 Kochstellen (inbegriffen 1 Abschluss-Element mod.TPA-7) • **FR** Rechaud gaz - 2 feux vifs (inclus 1 Élément de jonction top mod.TPA-7) • **ES** Sobres de cocción gas - 2 quemadores (incluida 1 Chapa de cierre para top mod.TPA-7)

**cm. 40x 70,5x 28h**



⚡ 13 kW \_\_\_\_\_ **1.168,00**  
11.180 kcal/h \_\_\_\_\_ 60 / 0,18

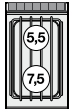

**PCT-78GP**  
18210850

**PIANO COTTURA GAS 4 FUOCHI (INCLUSA 1**  
**TESTATA CHIUSURA PIANO MOD.TPA-7)**

**EN** Gas heated boiling unit - 4 burners (included 1 Head end filler strip mod.TPA-7) • **DE** Gas-Kochplatte - 4 Kochstellen (inbegriffen 1 Abschluss-Element mod.TPA-7) • **FR** Rechaud gaz - 4 feux vifs (inclus 1 Élément de jonction top mod.TPA-7) • **ES** Sobres de cocción gas - 4 quemadores (incluida 1 Chapa de cierre para top mod.TPA-7)

**cm. 80x 70,5x 28h**



⚡ 22 kW \_\_\_\_\_ **2.018,00**  
18.920 kcal/h \_\_\_\_\_ 73 / 0,35

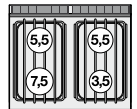

**PCT-712GP**  
18211250

**PIANO COTTURA GAS 6 FUOCHI (INCLUSA 1**  
**TESTATA CHIUSURA PIANO MOD.TPA-7)**

**EN** Gas heated boiling unit - 6 burners (included 1 Head end filler strip mod.TPA-7) • **DE** Gas-kochplatte - 6 Kochstellen (inbegriffen 1 Abschluss-Element mod.TPA-7) • **FR** Rechaud gaz - 6 feux vifs (inclus 1 Élément de jonction top mod.TPA-7) • **ES** Sobres de cocción gas - 6 quemadores (incluida 1 Chapa de cierre para top mod.TPA-7)

**cm. 120x 70,5x 28h**



⚡ 35 kW \_\_\_\_\_ **2.900,00**  
30.100 kcal/h \_\_\_\_\_ 119 / 0,51

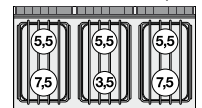

**PCT-716GP**  
18211650

**PIANO COTTURA GAS 8 FUOCHI (INCLUSA 1**  
**TESTATA CHIUSURA PIANO MOD.TPA-7)**

**EN** Gas heated boiling unit - 8 burners (included 1 Head end filler strip mod.TPA-7) • **DE** Gas-kochplatte - 8 Kochstellen (inbegriffen 1 Abschluss-Element mod.TPA-7) • **FR** Rechaud gaz - 8 feux vifs (inclus 1 Élément de jonction top mod.TPA-7) • **ES** Sobres de cocción gas - 8 quemadores (incluida 1 Chapa de cierre para top mod.TPA-7)

**cm. 160x 70,5x 28h**



⚡ 44 kW \_\_\_\_\_ **3.906,00**  
37.840 kcal/h \_\_\_\_\_ 146 / 0,78

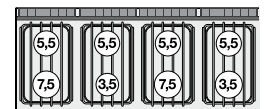

70



Le immagini presentate non sono vincolanti. La ditta si riserva di apportare modifiche senza preavviso. • The pictures are purely representative. The manufacturer reserves the right to modify the technical data and models without previous notice. • Les images

LO

présentées ne nous engagent pas. La Société se réserve le droit d'apporter tout modification sans préavis. • Die dargestellten Abbildungen sind nicht verbindlich. Technische Änderungen vorbehalten. • Las imágenes presentadas no son vinculantes. El Fabricante se reserva el derecho de modificar sus productos sin previo aviso.

01/20

197



# PIANI COTTURA A GAS - TOP

MOD. \_\_\_\_\_  
COD. \_\_\_\_\_

DESCRIZIONE/DESCRIPTION/BEZEICHNUNG/DESCRIPTION/DESCRIPCIÓN  
DIMENSIONI/DIMENSIONS/ABMESSUNGEN/DIMENSIONS/DIMENSIONES

POTENZA/POWER/LEISTUNG/PUISSANCE/POTENCIA  
VOLTAGGIO/VOLTAGE/SPANNUNG/VOLTAGE/VOLTAJE

kw  
kcal/h

PREZZO/PRICE €  
KG / M<sup>3</sup>  
PREIS/PRIX/PRECIO

**PC1T-74G**  
18210453

**PIANO COTTURA GAS 1 FUOCO (INCLUSA 1 TESTATA CHIUSURA PIANO MOD.TPA-7)**  
**EN** Gas heated boiling unit - 1 burner (included 1 Head end filler strip mod.TPA-7) • **DE** Gas-kochplatte - 1 Kochstellen (inbegriffen 1 Abschluss-Element mod.TPA-7) • **FR** Rechaud gaz - 1 feux vifs (inclus 1 Élément de jonction top mod.TPA-7) • **ES** Sobres de cocción gas - 1 quemador (incluida 1 Chapa de cierre para top mod.TPA-7)  
**cm. 40x 70,5x 28h**



10 kW  
8.600 kcal/h

**1.357,00**  
60 / 0,18



**PC2T-78G**  
18210853

**PIANO COTTURA GAS 2 FUOCHI (INCLUSA 1 TESTATA CHIUSURA PIANO MOD.TPA-7)**  
**EN** Gas heated boiling unit - 2 burners (included 1 Head end filler strip mod.TPA-7) • **DE** Gas-kochplatte - 2 Kochstellen (inbegriffen 1 Abschluss-Element mod.TPA-7) • **FR** Rechaud gaz - 2 feux vifs (inclus 1 Élément de jonction top mod.TPA-7) • **ES** Sobres de cocción gas - 2 quemadores (incluida 1 Chapa de cierre para top mod.TPA-7)  
**cm. 80x 70,5x 28h**



17 kW  
14.620 kcal/h

**2.068,00**  
73 / 0,35

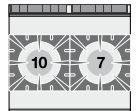

**PC3T-712G**  
18211253

**PIANO COTTURA GAS 3 FUOCHI (INCLUSA 1 TESTATA CHIUSURA PIANO MOD.TPA-7)**  
**EN** Gas heated boiling unit - 3 burners (included 1 Head end filler strip mod.TPA-7) • **DE** Gas-kochplatte - 3 Kochstellen (inbegriffen 1 Abschluss-Element mod.TPA-7) • **FR** Rechaud gaz - 3 feux vifs (inclus 1 Élément de jonction top mod.TPA-7) • **ES** Sobres de cocción gas - 3 quemadores (incluida 1 Chapa de cierre para top mod.TPA-7)  
**cm. 120x 70,5x 28h**



27 kW  
23.220 kcal/h

**2.977,00**  
119 / 0,51

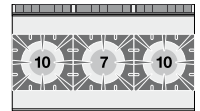

**PCWT-74G**  
18210454

**PIANO COTTURA GAS "WOK" 1 FUOCO - FIAMMA VERTICALE - ANELLO WOK (INCLUSA 1 TESTATA CHIUSURA PIANO MOD.TPA-7)**  
**EN** Gas heated boiling "WOK" - 1 burner - vertical flame - Wok ring (included 1 Head end filler strip mod.TPA-7) • **DE** Gas-Kochplatte "WOK" - 1 Kochstellen - vertikaler Flamme - Wok Aufsatzring (inbegriffen 1 Abschluss-Element mod.TPA-7) • **FR** Rechaud gaz "WOK" - 1 feux vifs - verticale de la flamme - Anneau Wok (inclus 1 Élément de jonction top mod.TPA-7) • **ES** Sobres de cocción gas "WOK" - 1 quemador - llama vertical - Anillo Wok (incluida 1 Chapa de cierre para top mod.TPA-7)  
**cm. 40x 70,5x 28h**



10 kW  
8.600 kcal/h

**1.734,00**  
63 / 0,18

**PAT-78G**  
18210851

**"PAELLERO" GAS (INCLUSA 1 TESTATA CHIUSURA PIANO MOD.TPA-7)**  
**EN** "PAELLERO" Gas (included 1 Head end filler strip mod.TPA-7) • **DE** "PAELLERO" Gas (inbegriffen 1 Abschluss-Element mod.TPA-7) • **FR** "PAELLERO" gaz (inclus 1 Élément de jonction top mod.TPA-7) • **ES** "PAELLERO" gas (incluida 1 Chapa de cierre para top mod.TPA-7)  
**cm. 80x 70,5x 28h**



11,5 kW  
9.890 kcal/h

**2.423,00**  
127 / 0,35

**TPT-74G**  
18290450

**TUTTA PIASTRA PIASTRA CM 37X57 (INCLUSA 1 TESTATA CHIUSURA PIANO MOD.TPA-7)**  
**EN** Solid top - Plate 37x57cm (included 1 Head end filler strip mod.TPA-7) • **DE** Kochplatte - Platte 37x57 cm (inbegriffen 1 Abschluss-Element mod.TPA-7) • **FR** Toute plaque - Plaque cm 37x57 (inclus 1 Élément de jonction top mod.TPA-7) • **ES** Placa de cocción - Placa cm 37x57 (incluida 1 Chapa de cierre para top mod.TPA-7)  
**cm. 40x 70,5x 28h**



7 kW  
6.020 kcal/h

**1.547,00**  
60 / 0,18



# TUTTAPIASTRA A GAS - TOP

MOD. \_\_\_\_\_  
COD. \_\_\_\_\_

DESCRIZIONE / DESCRIPTION / BEZEICHNUNG / DESCRIPTION / DESCRIPCIÓN  
DIMENSIONI / DIMENSIONS / ABMESSUNGEN / DIMENSIONS / DIMENSIONES

POTENZA / POWER / LEISTUNG / PUISSANCE / POTENCIA  
VOLTAGGIO / VOLTAGE / SPANNUNG / VOLTAGE / VOLTAJE

⚡ kW  
kcal/h

PREZZO / PRICE €  
PREIS / PRIX / PRECIO  
KG / M<sup>3</sup>

**TPT-78G**  
18290850

**TUTTA PIASTRA PIASTRA CM 77X57 (INCLUSA 1 TESTATA CHIUSURA PIANO MOD.TPA-7)**

**EN** Solid top - Plate 77x57cm (included 1 Head end filler strip mod.TPA-7) • **DE** Kochplatte - Platte 77x57 cm (inbegriffen 1 Abschluss-Element mod.TPA-7) • **FR** Toute plaque - Plaque cm. 77x57 (inclus 1 Élément de jonction top mod.TPA-7) • **ES** Placa de cocción - Placa cm 77x57 (incluida 1 Chapa de cierre para top mod. TPA-7)

**cm. 80x 70,5x 28h**



⚡ 12 kW  
10.320 kcal/h

**2.132,00**  
149 / 0,35

**TPT-78ET**  
18120830

**TUTTA PIASTRA PIASTRA CM. 70X50 - 4 ZONE (INCLUSA 1 TESTATA CHIUSURA PIANO MOD. TPA-7)**

**EN** Solid top - Plate cm. 70x50- 4 zones (included 1 Head end filler strip mod.TPA-7) • **DE** Kochplatten - Platte cm. 70x50 - 4 zonen (inbegriffen 1 Abschluss-Element mod.TPA-7) • **FR** Toute plaque - Plaque cm. 70x50 - 4 zones (inclus 1 Élément de jonction top mod. TPA-7) • **ES** Placa de cocción - Placa cm. 70x50 - 4 zonas (incluida 1 Chapa de cierre para top mod.TPA-7)

**cm. 80x 70,5x 28h**



⚡ 10 kW  
400V~3N  
50/60 Hz

**2.641,00**  
116 / 0,35

**TP2T-78GP**  
18300850

**TUTTA PIASTRA + 2 FUOCHI - PIASTRA CM 37X57 (INCLUSA 1 TESTATA CHIUSURA PIANO MOD.TPA-7)**

**EN** Solid top + 2 burners - Plate 37x57 (included 1 Head end filler strip mod.TPA-7) • **DE** Kochplatte + 2 Gaskochstellen - Platte 37x57 (inbegriffen 1 Abschluss-Element mod.TPA-7) • **FR** Toute plaque + 2 brûleurs - Plaque cm 37x57 (inclus 1 Élément de jonction top mod.TPA-7) • **ES** Placa de cocción + 2 fuegos - Placa cm 37x57 (incluida 1 Chapa de cierre para top mod. TPA-7)

**cm. 80x 70,5x 28h**



⚡ 20 kW  
17.200 kcal/h

**2.467,00**  
158 / 0,35

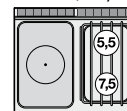

**TP2T-712GP**  
18291250

**TUTTA PIASTRA + 2 FUOCHI PIASTRA CM. 77X57 (INCLUSA 1 TESTATA CHIUSURA PIANO MOD.TPA-7)**

**EN** Solid top + 2 burners - Plate 77x57 (included 1 Head end filler strip mod.TPA-7) • **DE** Kochplatte + 2 Gaskochstellen - Platte 77x57 (inbegriffen 1 Abschluss-Element mod.TPA-7) • **FR** Toute plaque + 2 brûleurs - Plaque cm. 77x57 (inclus 1 Élément de jonction top mod.TPA-7) • **ES** Placa de cocción + 2 fuegos - Placa cm. 77x57 (incluida 1 Chapa de cierre para top mod. TPA-7)

**cm. 120x 70,5x 28h**



⚡ 25 kW  
21.500 kcal/h

**3.113,00**  
175 / 0,51

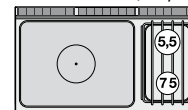

**TP4T-712GP**  
18301250

**TUTTA PIASTRA + 4 FUOCHI PIASTRA CM. 37X57 (INCLUSA 1 TESTATA CHIUSURA PIANO MOD.TPA-7)**

**EN** Solid top + 4 burners - Plate 37x57 (included 1 Head end filler strip mod.TPA-7) • **DE** Kochplatte + 4 Gaskochstellen - Platte 37x57 (inbegriffen 1 Abschluss-Element mod.TPA-7) • **FR** Toute plaque + 4 brûleurs - Plaque cm. 37x57 (inclus 1 Élément de jonction top mod.TPA-7) • **ES** Placa de cocción + 4 fuegos - Placa cm. 37x57 (incluida 1 Chapa de cierre para top mod. TPA-7)

**cm. 120x 70,5x 28h**



⚡ 29 kW  
24.940 kcal/h

**3.373,00**  
202 / 0,51

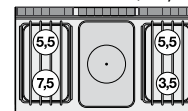

Le immagini presentate non sono vincolanti. La ditta si riserva di apportare modifiche senza preavviso. • The pictures are purely representative. The manufacturer reserves the right to modify the technical data and models without previous notice. • Les images

LO

présentées ne nous engagent pas. La Société se réserve le droit d'apporter tout modification sans préavis. • Die dargestellten Abbildungen sind nicht verbindlich. Technische Änderungen vorbehalten. • Las imágenes presentadas no son vinculantes. El Fabricante se reserva el derecho de modificar sus productos sin previo aviso.

01/20

**199**

70

# BAGNOMARIA ELETTRICI - TOP

MOD. \_\_\_\_\_  
COD. \_\_\_\_\_

DESCRIZIONE/DESCRIPTION/BEZEICHNUNG/DESCRIPTION/DESCRIPCIÓN  
DIMENSIONI/DIMENSIONS/ABMESSUNGEN/DIMENSIONS/DIMENSIONES

POTENZA/POWER/LEISTUNG/PUISSANCE/POTENCIA  
VOLTAGGIO/VOLTAGE/SPANNUNG/VOLTAGE/VOLTAJE

⚡ kW  
kcal/h  
V~  
Hz

PREZZO/PRICE €  
PREIS/PRIX/PRECIO €  
KG / M<sup>3</sup>

**BMT-74EM**  
18050410

**BAGNOMARIA MONOFASE VASCA PER GN 1/1 H.15 (INCLUSA 1 TESTATA CHIUSURA PIANO MOD.TPA-7)**

**EN** Bain marie singlephase - Bowl for GN 1/1 h.15 (included 1 Head end filler strip mod.TPA-7) • **DE** Wasserbäder einphasig - Becken GN 1/1 h.15 (inbegriffen 1 Abschluss-Element mod.TPA-7) • **FR** Bain marie monophasé - Cuve GN 1/1 h.15 (inclus 1 Élément de jonction top mod.TPA-7) • **ES** Baño de maría monofásico - Cuba para GN 1/1 15h (incluida 1 Chapa de cierre para top mod.TPA-7)  
**cm. 40x 70,5x 28h**



⚡ 2,1 kW  
230V~  
50/60 Hz

**1.057,00**  
35 / 0,18

**BMT-78ET**  
18050830

**BAGNOMARIA TRIFASE VASCA PER GN 2/1 15H (INCLUSA 1 TESTATA CHIUSURA PIANO MOD.TPA-7)**

**EN** Bain marie threephase - Bowl for GN 2/1 15h (included 1 Head end filler strip mod.TPA-7) • **DE** Wasserbäder dreiphasig - Becken GN 2/1 15h (inbegriffen 1 Abschluss-Element mod.TPA-7) • **FR** Bain marie triphase - Cuve GN 2/1 15h (inclus 1 Élément de jonction top mod.TPA-7) • **ES** Baño de maría trifásico - Cuba para GN 2/1 15h (incluida 1 Chapa de cierre para top mod.TPA-7)  
**cm. 80x 70,5x 28h**



⚡ 4,2 kW  
400V~2N  
230V~3  
50/60 Hz

**1.432,00**  
54 / 0,35

**BMT-74G**  
18220450

**BAGNOMARIA GAS VASCA PER GN 1/1 H.15 (INCLUSA 1 TESTATA CHIUSURA PIANO MOD.TPA-7)**

**EN** Gas bain-marie - Bowl for GN 1/1 h.15 (included 1 Head end filler strip mod.TPA-7) • **DE** Gas Wasserbad - Becken GN 1/1 h.15 (inbegriffen 1 Abschluss-Element mod.TPA-7) • **FR** Bain-marie gaz - Cuve pour GN 1/1 h.15 (inclus 1 Élément de jonction top mod.TPA-7) • **ES** Baño de maría gas - Cuba para GN 1/1 15h (incluida 1 Chapa de cierre para top mod.TPA-7)  
**cm. 40x 70,5x 28h**



⚡ 3,5 kW  
3.010 kcal/h

**1.354,00**  
43 / 0,18

**BMT-78G**  
18220850

**BAGNOMARIA GAS VASCA PER GN 2/1 H.15 (INCLUSA 1 TESTATA CHIUSURA PIANO MOD.TPA-7)**

**EN** Gas bain-marie - Bowl for GN 2/1 h.15 (included 1 Head end filler strip mod.TPA-7) • **DE** Gas Wasserbad - Becken GN 2/1 h.15 (inbegriffen 1 Abschluss-Element mod.TPA-7) • **FR** Bain-marie gaz - Cuve pour GN 2/1 h.15 (inclus 1 Élément de jonction top mod.TPA-7) • **ES** Baño de maría gas - Cuba para GN 2/1 15h (incluida 1 Chapa de cierre para top mod.TPA-7)  
**cm. 80x 70,5x 28h**



⚡ 6,5 kW  
5.590 kcal/h

**1.856,00**  
61 / 0,35

**BST-74EM**  
18040410

**CONTENITORE CALDO CON INFRAROSSO MONOFASE VASCA CM. 30,5X51X16,5H CON FALSOFONDO FORATO (INCLUSA 1 TESTATA CHIUSURA PIANO MOD.TPA-7)**

**EN** Fry dump singlephase with infra-red heater. Bowl cm. 30,5x51x16,5h with perforated double bottom (included 1 Head end filler strip mod.TPA-7) • **DE** Frittenwanne Einphasig mit Infrarot-strahler. Becke cm. 30,5x51x16,5h mit gelochtem Bodenrost (inbegriffen 1 Abschluss-Element mod.TPA-7) • **FR** Silo a frites monophasé avec infrarouge. Cuve cm 30,5x51x16,5h avec double-fond perforé. (inclus 1 Élément de jonction top mod.TPA-7) • **ES** Contenedor caliente por infrarrojo monofásico. Cuba cm. 30,5x51x16,5h con falso fondo agujereado (incluida 1 Chapa de cierre para top mod.TPA-7)  
**cm. 40x 70,5x 28h**



⚡ 1,47 kW  
230V~  
50/60 Hz

**1.384,00**  
36 / 0,21

MOD. \_\_\_\_\_  
COD. \_\_\_\_\_

DESCRIZIONE / DESCRIPTION / BEZEICHNUNG / DESCRIPTION / DESCRIPCIÓN  
DIMENSIONI / DIMENSIONS / ABMESSUNGEN / DIMENSIONS / DIMENSIONES

POTENZA / POWER / LEISTUNG / PUISSANCE / POTENCIA  
VOLTAGGIO / VOLTAGE / SPANNUNG / VOLTAGE / VOLTAJE

⚡ kW \_\_\_\_\_  
kcal/h \_\_\_\_\_  
V~ \_\_\_\_\_  
Hz \_\_\_\_\_

PREZZO / PRICE € \_\_\_\_\_  
PREIS / PRIX / PRECIO € \_\_\_\_\_  
KG / M<sup>3</sup> \_\_\_\_\_

**CPT-74ET**  
18100430

**CUOCIPASTA TRIFASE LT. 17 VASCA CM. 31X33,5X22H. RUBINETTO SCARICO (CESTI ESCLUSI) (INCLUSA 1 TESTATA CHIUSURA PIANO MOD.TPA-7)**

**EN** Pasta cooker threephase 17 lts. Tank cm. 31x33,5x22h. Drain-tap (BASKETS EXCLUDED) (included 1 Head end filler strip mod.TPA-7) • **DE** Nudelkocher dreiphasig lt.17 Becken cm. 31x33,5x22h. Ablasshahn (KORB AUSGESCHLOSSEN) (inbegriffen 1 Abschluss-Element mod.TPA-7) • **FR** Cuiseur à pates triphase lt.17 Cuve cm. 31x33,5x22h. Robinet de vidange (PANIERS EXCLUS) (inclus 1 Élément de jonction top mod.TPA-7) • **ES** Cuece pasta trifásico lt.17 Cuba cm. 31x33,5x22h. Grifo descarga (CESTAS EXCLUIDAS) (incluida 1 Chapa de cierre para top mod.TPA-7)  
**cm. 40x 70,5x 28h**



⚡ 5 kW \_\_\_\_\_ **1.541,00**  
400V~3N \_\_\_\_\_ 35 / 0,18  
230V~ \_\_\_\_\_  
50/60 Hz \_\_\_\_\_

**COMBINAZIONI**

- Combinations / • Zusammenstellungen
- Combinaisons / • Combinación múltiple



**CPT-76ET**  
18100630

**CUOCIPASTA TRIFASE LT. 25 VASCA CM. 51X31X22H. RUBINETTO SCARICO (CESTI ESCLUSI) (INCLUSA 1 TESTATA CHIUSURA PIANO MOD.TPA-7)**

**EN** Pasta cooker threephase 25 lts. Tank cm. 51x31x22h. Drain-tap (BASKETS EXCLUDED) (included 1 Head end filler strip mod.TPA-7) • **DE** Nudelkocher dreiphasig lt.25 Becken cm. 51x31x22h. Ablasshahn (KORB AUSGESCHLOSSEN) (inbegriffen 1 Abschluss-Element mod.TPA-7) • **FR** Cuiseur à pates triphase lt.25 Cuve cm. 51x31x22h. Robinet de vidange (PANIERS EXCLUS) (inclus 1 Élément de jonction top mod.TPA-7) • **ES** Cuece pasta trifásico lt.25 Cuba cm. 51x31x22h. Grifo descarga (CESTAS EXCLUIDAS) (incluida 1 Chapa de cierre para top mod.TPA-7)  
**cm. 60x 70,5x 28h**



⚡ 7,5 kW \_\_\_\_\_ **1.761,00**  
400V~3N \_\_\_\_\_ 45 / 0,26  
50/60 Hz \_\_\_\_\_

**COMBINAZIONI**

- Combinations / • Zusammenstellungen
- Combinaisons / • Combinación múltiple



# CUOCIPASTA A GAS - TOP

MOD. \_\_\_\_\_  
COD. \_\_\_\_\_

DESCRIZIONE/DESCRIPTION/BEZEICHNUNG/DESCRIPTION/DESCRIPCIÓN  
DIMENSIONI/DIMENSIONS/ABMESSUNGEN/DIMENSIONS/DIMENSIONES

POTENZA/POWER/LEISTUNG/PUISSANCE/POTENCIA  
VOLTAGGIO/VOLTAGE/SPANNUNG/VOLTAGE/VOLTAJE

⚡ kW kcal/h  
⚡ kW V~ Hz

PREZZO/PRICE €  
PREIS/PRIX/PRECIO €  
KG / M<sup>3</sup>

**CPT-74G**  
18270450

**CUOCIPASTA A GAS CAPACITA' LT. 13  
VASCA CM. 31X33,5X18H. RUBINETTO  
SCARICO (CESTI ESCLUSI) (INCLUSA 1 TESTATA  
CHIUSURA PIANO MOD.TPA-7)**

**EN** Gas pasta cookers Tank capacity 13 lts. Tank cm. 31x33,5x18h. Drain-tap (BASKETS EXCLUDED) (included 1 Head end filler strip mod.TPA-7) • **DE** Gas -Nudelkocher Beckeninhalte lt.13 Becken cm. 31x33,5x18h. Ablasshahn (KORB AUSGESCHLOSSEN) (inbegriffen 1 Abschluss-Element mod.TPA-7) • **FR** Cuiseur à pates gaz Cuve lt.13 Cuve cm. 31x33,5x18h. Robinet de vidange (PANIERS EXCLUS) (inclus 1 Elément de jonction top mod.TPA-7) • **ES** Cuece pasta gas Cuba 13 lt. Cuba cm. 31x33,5x18h. Grifo descarga (CESTAS EXCLUIDAS) (incluida 1 Chapa de cierre para top mod.TPA-7)  
**cm. 40x 70,5x 28h**



⚡ 6 kW 1.613,00  
5.160 kcal/h 38 / 0,18

**COMBINAZIONI**

- Combinations / • Zusammenstellungen
- Combinaisons / • Combinación múltiple



**CPT-76G**  
18270650

**CUOCIPASTA A GAS CAPACITA' LT. 19 VASCA  
CM. 51X31X18H. RUBINETTO SCARICO (CESTI  
ESCLUSI) (INCLUSA 1 TESTATA CHIUSURA  
PIANO MOD.TPA-7)**

**EN** Gas pasta cookers Tank capacity 19 lts. Tank cm. 51x31x18h. Drain-tap (BASKETS EXCLUDED) (included 1 Head end filler strip mod.TPA-7) • **DE** Gas -Nudelkocher Beckeninhalte lt. 19 Becken cm. 51x31x18h. Ablasshahn (KORB AUSGESCHLOSSEN) (inbegriffen 1 Abschluss-Element mod.TPA-7) • **FR** Cuiseur à pates gaz Cuve lt.19 Cuve cm. 51x31x18h. Robinet de vidange (PANIERS EXCLUS) (inclus 1 Elément de jonction top mod.TPA-7) • **ES** Cuece pasta gas Cuba 19 lt. Cuba cm. 51x31x18h. Grifo descarga (CESTAS EXCLUIDAS) (incluida 1 Chapa de cierre para top mod.TPA-7)  
**cm. 60x 70,5x 28h**



⚡ 9 kW 1.906,00  
7.740 kcal/h 49 / 0,26

**COMBINAZIONI**

- Combinations / • Zusammenstellungen
- Combinaisons / • Combinación múltiple



**FTLT-74ET**  
18060431

**FRY-TOP ELETTRICO LISCIO, PIASTRA  
CM.36X51 (INCLUSA 1 TESTATA CHIUSURA  
PIANO MOD.TPA-7)**

**EN** Electric Fry-top smooth griddle, plate cm.36x51 (included 1 Head end filler strip mod.TPA-7) • **DE** Griddleplatte elektrische glatt, platte cm.36x51 (inbegriffen 1 Abschluss-Element mod.TPA-7) • **FR** Plaque électriques lisse, plaque cm.36x51 (inclus 1 Elément de jonction top mod.TPA-7) • **ES** Fry-top eléctrico liso, plancha cm.36x51 (incluida 1 Chapa de cierre para top mod.TPA-7)  
**cm. 40x 70,5x 28h**



⚡ 5,55 kW 1.443,00  
400V~3N 58 / 0,18  
230V~3  
50/60 Hz

# FRY-TOP ELETTRICI - TOP

MOD. \_\_\_\_\_  
COD. \_\_\_\_\_

DESCRIZIONE/DESCRIPTION/BEZEICHNUNG/DESCRIPTION/DESCRIPCIÓN  
DIMENSIONI/DIMENSIONS/ABMESSUNGEN/DIMENSIONS/DIMENSIONES

POTENZA/POWER/LEISTUNG/PUISSANCE/POTENCIA  
VOLTAGGIO/VOLTAGE/SPANNUNG/VOLTAGE/VOLTAJE

⚡ kW kcal/h  
⚡ kW V~ Hz

PREZZO/PRICE €  
PREIS/PRIX/PRECIO €  
KG / M<sup>3</sup>

**FTLT-74ETS**  
18060434

**FRY-TOP ELETTRICO LISCIO CROMATO SUPERCHROME (MOCA APPROVED), PIASTRA CM.36X51 (INCLUSA 1 TESTATA CHIUSURA PIANO MOD.TPA-7)**

**EN** Electric Fry-top smooth chromed griddle SUPERCHROME (Moca Approved), plate cm.36x51 (included 1 Head end filler strip mod.TPA-7) • **DE** Griddleplatte elektrische glatt hartverchromt SUPERCHROME (Moca Approved), platte cm.36x51 (inbegriffen 1 Abschluss-Element mod.TPA-7) • **FR** Plaque électriques lisse chromée SUPERCHROME (Moca Approved), plaque cm.36x51 (inclus 1 Élément de jonction top mod.TPA-7) • **ES** Fry-top eléctrico liso cromado SUPERCHROME (Moca Approved), plancha cm.36x51 (incluida 1 Chapa de cierre para top mod.TPA-7)  
**cm. 40x 70,5x 28h**



⚡ 5,55 kW 1.694,00  
400V~3N 58 / 0,18  
230V~3  
50/60 Hz



**FTRT-74ET**  
18060433

**FRY-TOP ELETTRICO RIGATO, PIASTRA CM.36X51 (INCLUSA 1 TESTATA CHIUSURA PIANO MOD.TPA-7)**

**EN** Electric Fry-top grooved griddle, plate cm.36x51 (included 1 Head end filler strip mod.TPA-7) • **DE** Griddleplatte elektrische gerillt, platte cm.36x51 (inbegriffen 1 Abschluss-Element mod.TPA-7) • **FR** Plaque électriques nervurée, plaque cm.36x51 (inclus 1 Élément de jonction top mod.TPA-7) • **ES** Fry-top eléctrico estriado, plancha cm.36x51 (incluida 1 Chapa de cierre para top mod.TPA-7)  
**cm. 40x 70,5x 28h**



⚡ 5,55 kW 1.558,00  
400V~3N 58 / 0,18  
230V~3  
50/60 Hz



**FTRT-74ETS**  
18060436

**FRY-TOP ELETTRICO RIGATO CROMATO SUPERCHROME (MOCA APPROVED), PIASTRA CM.36X51 (INCLUSA 1 TESTATA CHIUSURA PIANO MOD.TPA-7)**

**EN** Electric Fry-top grooved chromed griddle SUPERCHROME (Moca Approved), plate cm.36x51 (included 1 Head end filler strip mod.TPA-7) • **DE** Griddleplatte elektrische gerillt hartverchromt SUPERCHROME (Moca Approved), platte cm.36x51 (inbegriffen 1 Abschluss-Element mod.TPA-7) • **FR** Plaque électriques nervurée chromée SUPERCHROME (Moca Approved), plaque cm.36x51 (inclus 1 Élément de jonction top mod.TPA-7) • **ES** Fry-top eléctrico estriado cromado SUPERCHROME (Moca Approved), plancha cm.36x51 (incluida 1 Chapa de cierre para top mod.TPA-7)  
**cm. 40x 70,5x 28h**



⚡ 5,55 kW 1.805,00  
400V~3N 58 / 0,18  
230V~3  
50/60 Hz



**FTLT-76ET**  
18060631

**FRY-TOP ELETTRICO LISCIO, PIASTRA CM.56X51 (INCLUSA 1 TESTATA CHIUSURA PIANO MOD.TPA-7)**

**EN** Electric Fry-top smooth griddle, plate cm.56x51 (included 1 Head end filler strip mod.TPA-7) • **DE** Griddleplatte elektrische glatt, platte cm.56x51 (inbegriffen 1 Abschluss-Element mod.TPA-7) • **FR** Plaque électriques lisse, plaque cm.56x51 (inclus 1 Élément de jonction top mod.TPA-7) • **ES** Fry-top eléctrico liso, plancha cm.56x51 (incluida 1 Chapa de cierre para top mod.TPA-7)  
**cm. 60x 70,5x 28h**



⚡ 7,4 kW 1.651,00  
400V~3N 67 / 0,26  
50/60 Hz



Le immagini presentate non sono vincolanti. La ditta si riserva di apportare modifiche senza preavviso. • The pictures are purely representative. The manufacturer reserves the right to modify the technical data and models without previous notice. • Les images

LO

présentées ne nous engagent pas. La Société se réserve le droit d'apporter tout modification sans préavis. • Die dargestellten Abbildungen sind nicht verbindlich. Technische Änderungen vorbehalten. • Las imágenes presentadas no son vinculantes. El Fabricante se reserva el derecho de modificar sus productos sin previo aviso.

01/20

203

70



# FRY-TOP ELETTRICI - TOP

MOD. \_\_\_\_\_  
COD. \_\_\_\_\_

DESCRIZIONE/DESCRIPTION/BEZEICHNUNG/DESCRIPTION/DESCRIPCIÓN  
DIMENSIONI/DIMENSIONS/ABMESSUNGEN/DIMENSIONS/DIMENSIONES

POTENZA/POWER/LEISTUNG/PUISSANCE/POTENCIA  
VOLTAGGIO/VOLTAGE/SPANNUNG/VOLTAGE/VOLTAJE

⚡ kW kcal/h  
⚡ kW V~ Hz

PREZZO/PRICE €  
PREIS/PRIX/PRECIO €  
KG / M<sup>3</sup>

**FTLT-76ETS**  
18060634

**FRY-TOP ELETTRICO LISCIO CROMATO SUPERCHROME (MOCA APPROVED), PIASTRA CM.56X51 (INCLUSA 1 TESTATA CHIUSURA PIANO MOD.TPA-7)**

**EN** Electric Fry-top smooth chromed griddle SUPERCHROME (Moca Approved), plate cm.56x51 (included 1 Head end filler strip mod.TPA-7) • **DE** Griddleplatte elektrische glatt hartverchromt SUPERCHROME (Moca Approved), platte cm.56x51 (inbegriffen 1 Abschluss-Element mod.TPA-7) • **FR** Plaque électriques lisse chromée SUPERCHROME (Moca Approved), plaque cm.56x51 (inclus 1 Élément de jonction top mod.TPA-7) • **ES** Fry-top eléctrico liso cromado SUPERCHROME (Moca Approved), plancha cm.56x51 (incluida 1 Chapa de cierre para top mod.TPA-7)  
**cm. 60x 70,5x 28h**



⚡ 7,4 kW **2.068,00**  
400V~3N 67 / 0,26  
50/60 Hz



**FTLRT-76ET**  
18060632

**FRY-TOP ELETTRICO 1/2 RIGATO + 1/2 LISCIO, PIASTRA CM.56X51 (INCLUSA 1 TESTATA CHIUSURA PIANO MOD.TPA-7)**

**EN** Electric Fry-top 1/2 grooved + 1/2 smooth, plate cm.56x51 (included 1 Head end filler strip mod.TPA-7) • **DE** Griddleplatte elektrische 1/2 gerillt + 1/2 glatt, platte cm.56x51 (inbegriffen 1 Abschluss-Element mod.TPA-7) • **FR** Plaque électriques 1/2 nervurée + 1/2 lisse, plaque cm.56x51 (inclus 1 Élément de jonction top mod.TPA-7) • **ES** Fry-top eléctrico 1/2 estriado + 1/2 liso, plancha cm.56x51 (incluida 1 Chapa de cierre para top mod.TPA-7)  
**cm. 60x 70,5x 28h**



⚡ 7,4 kW **1.780,00**  
400V~3N 67 / 0,26  
50/60 Hz



**FTLRT-76ETS**  
18060635

**FRY-TOP ELETTRICO 1/2 RIGATO + 1/2 LISCIO CROMATO SUPERCHROME (MOCA APPROVED), PIASTRA CM.56X51 (INCLUSA 1 TESTATA CHIUSURA PIANO MOD.TPA-7)**

**EN** Electric Fry-top 1/2 grooved + 1/2 smooth chromed griddle SUPERCHROME (Moca Approved), plate cm.56x51 (included 1 Head end filler strip mod.TPA-7) • **DE** Griddleplatte elektrische 1/2 gerillt + 1/2 glatt hartverchromt SUPERCHROME (Moca Approved), platte cm.56x51 (inbegriffen 1 Abschluss-Element mod.TPA-7) • **FR** Plaque électriques 1/2 nervurée + 1/2 lisse chromée SUPERCHROME (Moca Approved), plaque cm.56x51 (inclus 1 Élément de jonction top mod.TPA-7) • **ES** Fry-top eléctrico 1/2 estriado + 1/2 liso cromado SUPERCHROME (Moca Approved), plancha cm.56x51 (incluida 1 Chapa de cierre para top mod.TPA-7)  
**cm. 60x 70,5x 28h**

⚡ 7,4 kW **2.192,00**  
400V~3N 67 / 0,26  
50/60 Hz



**FTRT-76ET**  
18060633

**FRY-TOP ELETTRICO RIGATO, PIASTRA CM.56X51 (INCLUSA 1 TESTATA CHIUSURA PIANO MOD.TPA-7)**

**EN** Electric Fry-top grooved griddle, plate cm.56x51 (included 1 Head end filler strip mod.TPA-7) • **DE** Griddleplatte elektrische gerillt, platte cm.56x51 (inbegriffen 1 Abschluss-Element mod.TPA-7) • **FR** Plaque électriques nervurée, plaque cm.56x51 (inclus 1 Élément de jonction top mod.TPA-7) • **ES** Fry-top eléctrico estriado, plancha cm.56x51 (incluida 1 Chapa de cierre para top mod.TPA-7)  
**cm. 60x 70,5x 28h**



⚡ 7,4 kW **1.909,00**  
400V~3N 67 / 0,26  
50/60 Hz



# FRY-TOP ELETTRICI - TOP

MOD. \_\_\_\_\_  
COD. \_\_\_\_\_

DESCRIZIONE/DESCRIPTION/BEZEICHNUNG/DESCRIPTION/DESCRIPCIÓN  
DIMENSIONI/DIMENSIONS/ABMESSUNGEN/DIMENSIONS/DIMENSIONES

POTENZA/POWER/LEISTUNG/PUISSANCE/POTENCIA  
VOLTAGGIO/VOLTAGE/SPANNUNG/VOLTAGE/VOLTAJE

⚡ kW kcal/h  
V~ Hz

PREZZO/PRICE €  
PREIS/PRIX/PRECIO €  
KG / M<sup>3</sup>

**FTRT-76ETS**  
18060636

**FRY-TOP ELETTRICO RIGATO CROMATO SUPERCHROME (MOCA APPROVED), PIASTRA CM.56X51 (INCLUSA 1 TESTATA CHIUSURA PIANO MOD.TPA-7)**

**EN** Electric Fry-top grooved chromed griddle SUPERCHROME (Moca Approved), plate cm.56x51 (included 1 Head end filler strip mod.TPA-7) • **DE** Griddleplatte elektrische gerillt hartverchromt SUPERCHROME (Moca Approved), platte cm.56x51 (inbegriffen 1 Abschluss-Element mod.TPA-7) • **FR** Plaque électriques nervurée chromée SUPERCHROME (Moca Approved), plaque cm.56x51 (inclus 1 Élément de jonction top mod.TPA-7) • **ES** Fry-top eléctrico estriado cromado SUPERCHROME (Moca Approved), plancha cm.56x51 (incluida 1 Chapa de cierre para top mod.TPA-7)  
**cm. 60x 70,5x 28h**



⚡ 7,4 kW **2.323,00**  
400V~3N 67 / 0,26  
50/60 Hz



**FTLT-78ET**  
18060831

**FRY-TOP ELETTRICO LISCIO, PIASTRA CM.76X51 - 2 ZONE DI COTTURA (INCLUSA 1 TESTATA CHIUSURA PIANO MOD.TPA-7)**

**EN** Electric Fry-top smooth griddle, plate cm.76x51 - 2 cooking areas (included 1 Head end filler strip mod.TPA-7) • **DE** Griddleplatte elektrische glatt, platte cm.76x51 - 2 Heizzonen (inbegriffen 1 Abschluss-Element mod.TPA-7) • **FR** Plaque électriques lisse, plaque cm.76x51 - 2 zones de cuisson (inclus 1 Élément de jonction top mod.TPA-7) • **ES** Fry-top eléctrico liso, plancha cm.76x51 - 2 zonas de cocción (incluida 1 Chapa de cierre para top mod.TPA-7)  
**cm. 80x 70,5x 28h**



⚡ 11,1 kW **2.145,00**  
400V~3N 103 / 0,35  
230V~3  
50/60 Hz



**FTLT-78ETS**  
18060834

**FRY-TOP ELETTRICO LISCIO CROMATO SUPERCHROME (MOCA APPROVED), PIASTRA CM.76X51 - 2 ZONE DI COTTURA (INCLUSA 1 TESTATA CHIUSURA PIANO MOD.TPA-7)**

**EN** Electric Fry-top smooth chromed griddle SUPERCHROME (Moca Approved), plate cm.76x51 - 2 cooking areas (included 1 Head end filler strip mod.TPA-7) • **DE** Griddleplatte elektrische glatt hartverchromt SUPERCHROME (Moca Approved), platte cm.76x51 - 2 Heizzonen (inbegriffen 1 Abschluss-Element mod.TPA-7) • **FR** Plaque électriques lisse chromée SUPERCHROME (Moca Approved), plaque cm.76x51 - 2 zones de cuisson (inclus 1 Élément de jonction top mod.TPA-7) • **ES** Fry-top eléctrico liso cromado SUPERCHROME (Moca Approved), plancha cm.76x51 - 2 zonas de cocción (incluida 1 Chapa de cierre para top mod.TPA-7)  
**cm. 80x 70,5x 28h**

⚡ 11,1 kW **2.676,00**  
400V~3N 103 / 0,35  
230V~3  
50/60 Hz



**FTLRT-78ET**  
18060832

**FRY-TOP ELETTRICO 1/2 RIGATO + 1/2 LISCIO, PIASTRA CM.76X51 - 2 ZONE DI COTTURA (INCLUSA 1 TESTATA CHIUSURA PIANO MOD.TPA-7)**

**EN** Electric Fry-top 1/2 grooved + 1/2 smooth, plate cm.76x51 - 2 cooking areas (included 1 Head end filler strip mod.TPA-7) • **DE** Griddleplatte elektrische 1/2 gerillt + 1/2 glatt, platte cm.76x51 - 2 Heizzonen (inbegriffen 1 Abschluss-Element mod.TPA-7) • **FR** Plaque électriques 1/2 nervurée + 1/2 lisse, plaque cm.76x51 - 2 zones de cuisson (inclus 1 Élément de jonction top mod.TPA-7) • **ES** Fry-top eléctrico 1/2 estriado + 1/2 liso, plancha cm.76x51 - 2 zonas de cocción (incluida 1 Chapa de cierre para top mod.TPA-7)  
**cm. 80x 70,5x 28h**



⚡ 11,1 kW **2.313,00**  
400V~3N 103 / 0,35  
230V~3  
50/60 Hz



70



Le immagini presentate non sono vincolanti. La ditta si riserva di apportare modifiche senza preavviso. • The pictures are purely representative. The manufacturer reserves the right to modify the technical data and models without previous notice. • Les images

LO

présentées ne nous engagent pas. La Société se réserve le droit d'apporter tout modification sans préavis. • Die dargestellten Abbildungen sind nicht verbindlich. Technische Änderungen vorbehalten. • Las imágenes presentadas no son vinculantes. El Fabricante se reserva el derecho de modificar sus productos sin previo aviso.

01/20

205

MOD. \_\_\_\_\_  
COD. \_\_\_\_\_

DESCRIZIONE/DESCRIPTION/BEZEICHNUNG/DESCRIPTION/DESCRIPCIÓN  
DIMENSIONI/DIMENSIONS/ABMESSUNGEN/DIMENSIONS/DIMENSIONES

POTENZA/POWER/LEISTUNG/PUISSANCE/POTENCIA  
VOLTAGGIO/VOLTAGE/SPANNUNG/VOLTAGE/VOLTAJE

⚡ kW kcal/h  
⚡ kW V~ Hz

PREZZO/PRICE €  
PREIS/PRIX/PRECIO €  
KG / M<sup>3</sup>

**FTLRT-78ETS FRY-TOP ELETTRICO 1/2 RIGATO + 1/2 LISCIO CROMATO SUPERCHROME (MOCA APPROVED), PIASTRA CM.76X51 - 2 ZONE DI COTTURA (INCLUSA 1 TESTATA CHIUSURA PIANO MOD.TPA-7)**

18060835

**EN** Electric Fry-top 1/2 grooved + 1/2 smooth chromed griddle SUPERCHROME (Moca Approved), plate cm.76x51 - 2 cooking areas (included 1 Head end filler strip mod.TPA-7) • **DE** Griddleplatte elektrische 1/2 gerillt + 1/2 glatt hartverchromt SUPERCHROME (Moca Approved), platte cm.76x51 - 2 Heizzonen (inbegriffen 1 Abschluss-Element mod.TPA-7) • **FR** Plaque électriques 1/2 nervurée + 1/2 lisse chromée SUPERCHROME (Moca Approved), plaque cm.76x51 - 2 zones de cuisson (inclus 1 Élément de jonction top mod.TPA-7) • **ES** Fry-top eléctrico 1/2 estriado + 1/2 liso cromado SUPERCHROME (Moca Approved), plancha cm.76x51 - 2 zonas de cocción (incluida 1 Chapa de cierre para top mod.TPA-7)  
**cm. 80x 70,5x 28h**



⚡ 11,1 kW 2.838,00  
400V~3N 103 / 0,35  
230V~3  
50/60 Hz



**FTRT-78ET FRY-TOP ELETTRICO RIGATO, PIASTRA CM.76X51 - 2 ZONE DI COTTURA (INCLUSA 1 TESTATA CHIUSURA PIANO MOD.TPA-7)**

18060833

**EN** Electric Fry-top grooved griddle, plate cm.76x51 - 2 cooking areas (included 1 Head end filler strip mod.TPA-7) • **DE** Griddleplatte elektrische gerillt, platte cm.76x51 - 2 Heizzonen (inbegriffen 1 Abschluss-Element mod.TPA-7) • **FR** Plaque électriques nervurée, plaque cm.76x51 - 2 zones de cuisson (inclus 1 Élément de jonction top mod.TPA-7) • **ES** Fry-top eléctrico estriado, plancha cm.76x51 - 2 zonas de cocción (incluida 1 Chapa de cierre para top mod.TPA-7)  
**cm. 80x 70,5x 28h**



⚡ 11,1 kW 2.440,00  
400V~3N 103 / 0,35  
230V~3  
50/60 Hz



**FTRT-78ETS FRY-TOP ELETTRICO RIGATO CROMATO SUPERCHROME (MOCA APPROVED), PIASTRA CM.76X51 - 2 ZONE DI COTTURA (INCLUSA 1 TESTATA CHIUSURA PIANO MOD.TPA-7)**

18060836

**EN** Electric Fry-top grooved chromed griddle SUPERCHROME (Moca Approved), plate cm.76x51 - 2 cooking areas (included 1 Head end filler strip mod.TPA-7) • **DE** Griddleplatte elektrische gerillt hartverchromt SUPERCHROME (Moca Approved), platte cm.76x51 - 2 Heizzonen (inbegriffen 1 Abschluss-Element mod.TPA-7) • **FR** Plaque électriques nervurée chromée SUPERCHROME (Moca Approved), plaque cm.76x51 - 2 zones de cuisson (inclus 1 Élément de jonction top mod.TPA-7) • **ES** Fry-top eléctrico estriado cromado SUPERCHROME (Moca Approved), plancha cm.76x51 - 2 zonas de cocción (incluida 1 Chapa de cierre para top mod.TPA-7)  
**cm. 80x 70,5x 28h**

⚡ 11,1 kW 2.996,00  
400V~3N 103 / 0,35  
230V~3  
50/60 Hz



**FTLT-712ET FRY-TOP ELETTRICO LISCIO, PIASTRA CM.116X51 - 2 ZONE DI COTTURA (INCLUSA 1 TESTATA CHIUSURA PIANO MOD.TPA-7)**

18061231

**EN** Electric Fry-top smooth griddle, plate cm.116x51 - 2 cooking areas (included 1 Head end filler strip mod.TPA-7) • **DE** Griddleplatte elektrische glatt, platte cm.116x51 - 2 Heizzonen (inbegriffen 1 Abschluss-Element mod.TPA-7) • **FR** Plaque électriques lisse, plaque cm.116x51 - 2 zones de cuisson (inclus 1 Élément de jonction top mod.TPA-7) • **ES** Fry-top eléctrico liso, plancha cm.116x51 - 2 zonas de cocción (incluida 1 Chapa de cierre para top mod.TPA-7)  
**cm. 120x 70,5x 28h**



⚡ 14,8 KW 3.036,00  
400V~3N 114 / 0,51  
50/60 Hz



# FRY-TOP ELETTRICI - TOP

MOD. \_\_\_\_\_  
COD. \_\_\_\_\_

DESCRIZIONE/DESCRIPTION/BEZEICHNUNG/DESCRIPTION/DESCRIPCIÓN  
DIMENSIONI/DIMENSIONS/ABMESSUNGEN/DIMENSIONS/DIMENSIONES

POTENZA/POWER/LEISTUNG/PUISSANCE/POTENCIA  
VOLTAGGIO/VOLTAGE/SPANNUNG/VOLTAGE/VOLTAJE

⚡ kW \_\_\_\_\_  
kcal/h \_\_\_\_\_  
V~ \_\_\_\_\_  
Hz \_\_\_\_\_

PREZZO/PRICE € \_\_\_\_\_  
PREIS/PRIX/PRECIO \_\_\_\_\_  
KG / M<sup>3</sup> \_\_\_\_\_

**FTLT-712ETS FRY-TOP ELETTRICO LISCIO CROMATO SUPERCHROME (MOCA APPROVED), PIASTRA CM.116X51 - 2 ZONE DI COTTURA (INCLUSA 1 TESTATA CHIUSURA PIANO MOD.TPA-7)**

18061234

**EN** Electric Fry-top smooth chromed griddle SUPERCHROME (Moca Approved), plate cm.116x51 - 2 cooking areas (included 1 Head end filler strip mod.TPA-7) • **DE** Griddleplatte elektrische glatt hartverchromt SUPERCHROME (Moca Approved), platte cm.116x51 - 2 Heizzonen (inbegriffen 1 Abschluss-Element mod.TPA-7) • **FR** Plaque électriques lisse chromée SUPERCHROME (Moca Approved), plaque cm.116x51 - 2 zones de cuisson (inclus 1 Élément de jonction top mod.TPA-7) • **ES** Fry-top eléctrico liso cromado SUPERCHROME (Moca Approved), plancha cm.116x51 - 2 zonas de cocción (incluida 1 Chapa de cierre para top mod.TPA-7)

**cm. 120x 70,5x 28h**



⚡ 14,8 kW \_\_\_\_\_ **3.784,00**  
400V~3N \_\_\_\_\_ 114 / 0,51  
50/60 Hz \_\_\_\_\_

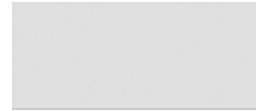

**FLRT-712ET FRY-TOP ELETTRICO 1/2 RIGATO + 1/2 LISCIO, PIASTRA CM.116X51 - 2 ZONE DI COTTURA (INCLUSA 1 TESTATA CHIUSURA PIANO MOD.TPA-7)**

18061232

**EN** Electric Fry-top 1/2 grooved + 1/2 smooth, plate cm.116x51 - 2 cooking areas (included 1 Head end filler strip mod.TPA-7) • **DE** Griddleplatte elektrische 1/2 gerillt + 1/2 glatt, platte cm.116x51 - 2 Heizzonen (inbegriffen 1 Abschluss-Element mod.TPA-7) • **FR** Plaque électriques 1/2 nervurée + 1/2 lisse, plaque cm.116x51 - 2 zones de cuisson (inclus 1 Élément de jonction top mod.TPA-7) • **ES** Fry-top eléctrico 1/2 estriado + 1/2 liso, plancha cm.116x51 - 2 zonas de cocción (incluida 1 Chapa de cierre para top mod.TPA-7)

**cm. 120x 70,5x 28h**

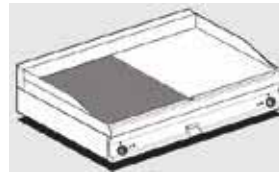

⚡ 14,8 kW \_\_\_\_\_ **3.187,00**  
400V~3N \_\_\_\_\_ 114 / 0,51  
50/60 Hz \_\_\_\_\_



**FTLRT-712ETS FRY-TOP ELETTRICO 1/2 RIGATO + 1/2 LISCIO CROMATO SUPERCHROME (MOCA APPROVED), PIASTRA CM.116X51 - 2 ZONE DI COTTURA (INCLUSA 1 TESTATA CHIUSURA PIANO MOD.TPA-7)**

18061235

**EN** Electric Fry-top 1/2 grooved + 1/2 smooth chromed griddle SUPERCHROME (Moca Approved), plate cm.116x51 - 2 cooking areas (included 1 Head end filler strip mod.TPA-7) • **DE** Griddleplatte elektrische 1/2 gerillt + 1/2 glatt hartverchromt SUPERCHROME (Moca Approved), platte cm.116x51 - 2 Heizzonen (inbegriffen 1 Abschluss-Element mod.TPA-7) • **FR** Plaque électriques 1/2 nervurée + 1/2 lisse chromée SUPERCHROME (Moca Approved), plaque cm.116x51 - 2 zones de cuisson (inclus 1 Élément de jonction top mod.TPA-7) • **ES** Fry-top eléctrico 1/2 estriado + 1/2 liso cromado SUPERCHROME (Moca Approved), plancha cm.116x51 - 2 zonas de cocción (incluida 1 Chapa de cierre para top mod.TPA-7)

**cm. 120x 70,5x 28h**

⚡ 14,8 kW \_\_\_\_\_ **4.013,00**  
400V~3N \_\_\_\_\_ 114 / 0,51  
50/60 Hz \_\_\_\_\_



**FRRT-712ET FRY-TOP ELETTRICO RIGATO, PIASTRA CM.116X51 - 2 ZONE DI COTTURA (INCLUSA 1 TESTATA CHIUSURA PIANO MOD.TPA-7)**

18061233

**EN** Electric Fry-top grooved griddle, plate cm.116x51 - 2 cooking areas (included 1 Head end filler strip mod.TPA-7) • **DE** Griddleplatte elektrische gerillt, platte cm.116x51 - 2 Heizzonen (inbegriffen 1 Abschluss-Element mod.TPA-7) • **FR** Plaque électriques nervurée, plaque cm.116x51 - 2 zones de cuisson (inclus 1 Élément de jonction top mod.TPA-7) • **ES** Fry-top eléctrico estriado, plancha cm.116x51 - 2 zonas de cocción (incluida 1 Chapa de cierre para top mod.TPA-7)

**cm. 120x 70,5x 28h**



⚡ 14,8 kW \_\_\_\_\_ **3.347,00**  
400V~3N \_\_\_\_\_ 114 / 0,51  
50/60 Hz \_\_\_\_\_



Le immagini presentate non sono vincolanti. La ditta si riserva di apportare modifiche senza preavviso. • The pictures are purely representative. The manufacturer reserves the right to modify the technical data and models without previous notice. • Les images

LO

présentées ne nous engagent pas. La Société se réserve le droit d'apporter tout modification sans préavis. • Die dargestellten Abbildungen sind nicht verbindlich. Technische Änderungen vorbehalten. • Las imágenes presentadas no son vinculantes. El Fabricante se reserva el derecho de modificar sus productos sin previo aviso.

01/20

207

70



# FRY-TOP ELETTRICI - TOP

MOD. \_\_\_\_\_  
COD. \_\_\_\_\_

DESCRIZIONE/DESCRIPTION/BEZEICHNUNG/DESCRIPTION/DESCRIPCIÓN  
DIMENSIONI/DIMENSIONS/ABMESSUNGEN/DIMENSIONS/DIMENSIONES

POTENZA/POWER/LEISTUNG/PUISSANCE/POTENCIA  
VOLTAGGIO/VOLTAGE/SPANNUNG/VOLTAGE/VOLTAJE

⚡ kW kcal/h  
V~ Hz

PREZZO/PRICE €  
PREIS/PRIX/PRECIO €  
KG / M<sup>3</sup>

**FTRT-712ETS FRY-TOP ELETTRICO RIGATO CROMATO SUPERCHROME (MOCA APPROVED), PIASTRA CM. 116X51 - 2 ZONE DI COTTURA (INCLUSA 1 TESTATA CHIUSURA PIANO MOD.TPA-7)**

18061236

**EN** Electric Fry-top grooved chromed griddle SUPERCHROME (Moca Approved), plate cm.116x51 - 2 cooking areas (included 1 Head end filler strip mod.TPA-7) • **DE** Griddleplatte elektrische gerillt hartverchromt SUPERCHROME (Moca Approved), platte cm.116x51 - 2 Heizzonen (inbegriffen 1 Abschluss-Element mod.TPA-7) • **FR** Plaque électriques nervurée chromée SUPERCHROME (Moca Approved), plaque cm.116x51 - 2 zones de cuisson (inclus 1 Élément de jonction top mod.TPA-7) • **ES** Fry-top eléctrico estriado cromado SUPERCHROME (Moca Approved), plancha cm.116x51 - 2 zonas de cocción (incluida 1 Chapa de cierre para top mod.TPA-7)  
**cm. 120x 70,5x 28h**



⚡ 14,8 kW **4.308,00**  
400V~3N 114 / 0,51  
50/60 Hz



**FTLT-712ET3 FRY-TOP ELETTRICO LISCIO, PIASTRA CM. 116X51 - 3 ZONE DI COTTURA (INCLUSA 1 TESTATA CHIUSURA PIANO MOD.TPA-7)**

1806123B

**EN** Electric Fry-top smooth griddle, plate cm.116x51 - 3 cooking areas (included 1 Head end filler strip mod.TPA-7) • **DE** Griddleplatte elektrische glatt, platte cm.116x51 - 3 Heizzonen (inbegriffen 1 Abschluss-Element mod.TPA-7) • **FR** Plaque électriques lisse, plaque cm.116x51 - 3 zones de cuisson (inclus 1 Élément de jonction top mod.TPA-7) • **ES** Fry-top eléctrico liso, plancha cm.116x51 - 3 zonas de cocción (incluida 1 Chapa de cierre para top mod.TPA-7)  
**cm. 120x 70,5x 28h**



⚡ 16,65 kW **3.443,00**  
400V~3N 114 / 0,51  
50/60 Hz

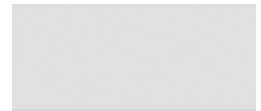

**FTLT-712ETS3 FRY-TOP ELETTRICO LISCIO CROMATO SUPERCHROME (MOCA APPROVED), PIASTRA CM. 116X51 - 3 ZONE DI COTTURA (INCLUSA 1 TESTATA CHIUSURA PIANO MOD.TPA-7)**

1806123E

**EN** Electric Fry-top smooth chromed griddle SUPERCHROME (Moca Approved), plate cm.116x51 - 3 cooking areas (included 1 Head end filler strip mod.TPA-7) • **DE** Griddleplatte elektrische glatt hartverchromt SUPERCHROME (Moca Approved), platte cm.116x51 - 3 Heizzonen (inbegriffen 1 Abschluss-Element mod.TPA-7) • **FR** Plaque électriques lisse chromée SUPERCHROME (Moca Approved), plaque cm.116x51 - 3 zones de cuisson (inclus 1 Élément de jonction top mod.TPA-7) • **ES** Fry-top eléctrico liso cromado SUPERCHROME (Moca Approved), plancha cm.116x51 - 3 zonas de cocción (incluida 1 Chapa de cierre para top mod.TPA-7)  
**cm. 120x 70,5x 28h**

⚡ 16,65 kW **4.076,00**  
400V~3N 114 / 0,51  
50/60 Hz

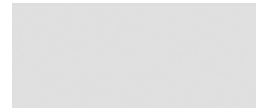

**FTLRT-712ET3 FRY-TOP ELETTRICO 1/3 RIGATO + 2/3 LISCIO, PIASTRA CM. 116X51 - 3 ZONE DI COTTURA (INCLUSA 1 TESTATA CHIUSURA PIANO MOD. TPA-7)**

1806123C

**EN** Electric Fry-top 1/3 grooved + 2/3 smooth, plate cm.116x51 - 3 cooking areas (included 1 Head end filler strip mod.TPA-7) • **DE** Griddleplatte elektrische 1/3 gerillt + 2/3 glatt, platte cm.116x51 - 3 Heizzonen (inbegriffen 1 Abschluss-Element mod.TPA-7) • **FR** Plaque électriques 1/3 nervurée + 2/3 lisse, plaque cm.116x51 - 3 zones de cuisson (inclus 1 Élément de jonction top mod.TPA-7) • **ES** Fry-top eléctrico 1/3 estriado + 2/3 liso, plancha cm.116x51 - 3 zonas de cocción (incluida 1 Chapa de cierre para top mod.TPA-7)  
**cm. 120x 70,5x 28h**



⚡ 16,65 kW **3.539,00**  
400V~3N 114 / 0,51  
50/60 Hz





# FRY-TOP ELETTRICI - TOP

MOD. \_\_\_\_\_  
COD. \_\_\_\_\_

DESCRIZIONE/DESCRIPTION/BEZEICHNUNG/DESCRIPTION/DESCRIPCIÓN  
DIMENSIONI/DIMENSIONS/ABMESSUNGEN/DIMENSIONS/DIMENSIONES

POTENZA/POWER/LEISTUNG/PUISSANCE/POTENCIA  
VOLTAGGIO/VOLTAGE/SPANNUNG/VOLTAGE/VOLTAJE

⚡ kcal/h  $\frac{kW}{\sqrt{V}}$   
Hz

PREZZO/PRICE €  
PREIS/PRIX/PRECIO €  
KG / M<sup>3</sup>

**FTLRT-712ETS3 FRY-TOP ELETTRICO 1/3 RIGATO + 2/3 LISCIO CROMATO SUPERCHROME (MOCA APPROVED), PIASTRA CM.116X51 - 3 ZONE DI COTTURA (INCLUSA 1 TESTATA CHIUSURA PIANO MOD.TPA-7)**

1806123F

**EN** Electric Fry-top 1/3 grooved + 2/3 smooth chromed griddle SUPERCHROME (Moca Approved), plate cm.116x51 - 3 cooking areas (included 1 Head end filler strip mod.TPA-7) • **DE** Griddleplatte elektrische 1/3 gerillt + 2/3 glatt hartverchromt SUPERCHROME (Moca Approved), platte cm.116x51 - 3 Heizzonen (inbegriffen 1 Abschluss-Element mod.TPA-7) • **FR** Plaque électriques 1/3 nervurée + 2/3 lisse chromée SUPERCHROME (Moca Approved), plaque cm.116x51 - 3 zones de cuisson (inclus 1 Élément de jonction top mod.TPA-7) • **ES** Fry-top eléctrico 1/3 estriado + 2/3 liso cromado SUPERCHROME (Moca Approved), plancha cm.116x51 - 3 zonas de cocción (incluida 1 Chapa de cierre para top mod.TPA-7)  
**cm. 120x 70,5x 28h**



⚡ 16,65 kW 4.227,00  
400V~3N 114 / 0,51  
50/60 Hz



**FTLT-74G FRY-TOP GAS LISCIO, PIASTRA CM.36X51 (INCLUSA 1 TESTATA CHIUSURA PIANO MOD. TPA-7)**

18230451

**EN** Gas Fry-top smooth griddle, plate cm.36x51 (included 1 Head end filler strip mod.TPA-7) • **DE** Gas-griddleplatte glatt, platte cm.36x51 (inbegriffen 1 Abschluss-Element mod.TPA-7) • **FR** Plaque gaz lisse, plaque cm.36x51 (inclus 1 Élément de jonction top mod.TPA-7) • **ES** Fry-top gas liso, plancha cm.36x51 (incluida 1 Chapa de cierre para top mod.TPA-7)  
**cm. 40x 70,5x 28h**



⚡ 7 kW 1.446,00  
6.020 kcal/h 63 / 0,18



**FTLT-74GS FRY-TOP GAS LISCIO CROMATO SUPERCHROME (MOCA APPROVED), PIASTRA CM.36X51 (INCLUSA 1 TESTATA CHIUSURA PIANO MOD.TPA-7)**

18230454

**EN** Gas Fry-top smooth chromed griddle SUPERCHROME (Moca Approved), plate cm.36x51 (included 1 Head end filler strip mod.TPA-7) • **DE** Gas-griddleplatte glatt hartverchromt SUPERCHROME (Moca Approved), platte cm.36x51 (inbegriffen 1 Abschluss-Element mod.TPA-7) • **FR** Plaque gaz lisse chromée SUPERCHROME (Moca Approved), plaque cm.36x51 (inclus 1 Élément de jonction top mod.TPA-7) • **ES** Fry-top gas liso cromado SUPERCHROME (Moca Approved), plancha cm.36x51 (incluida 1 Chapa de cierre para top mod.TPA-7)  
**cm. 40x 70,5x 28h**

⚡ 7 kW 1.799,00  
6.020 kcal/h 63 / 0,18



**FTRT-74G FRY-TOP GAS RIGATO, PIASTRA CM.36X51 (INCLUSA 1 TESTATA CHIUSURA PIANO MOD. TPA-7)**

18230453

**EN** Gas Fry-top grooved griddle, plate cm.36x51 (included 1 Head end filler strip mod.TPA-7) • **DE** Gas-griddleplatte gerillt, platte cm.36x51 (inbegriffen 1 Abschluss-Element mod.TPA-7) • **FR** Plaque gaz nervurée, plaque cm.36x51 (inclus 1 Élément de jonction top mod.TPA-7) • **ES** Fry-top gas estriado, plancha cm.36x51 (incluida 1 Chapa de cierre para top mod.TPA-7)  
**cm. 40x 70,5x 28h**

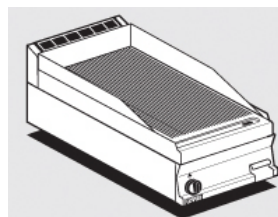

⚡ 7 kW 1.604,00  
6.020 kcal/h 63 / 0,18



# FRY-TOP A GAS - TOP

MOD. \_\_\_\_\_  
COD. \_\_\_\_\_

DESCRIZIONE/DESCRIPTION/BEZEICHNUNG/DESCRIPTION/DESCRIPCIÓN  
DIMENSIONI/DIMENSIONS/ABMESSUNGEN/DIMENSIONS/DIMENSIONES

POTENZA/POWER/LEISTUNG/PUISSANCE/POTENCIA  
VOLTAGGIO/VOLTAGE/SPANNUNG/VOLTAGE/VOLTAJE

⚡ kW  
kcal/h

PREZZO/PRICE €  
PREIS/PRIX/PRECIO €  
KG / M<sup>3</sup>

**FTRT-74GS**  
18230456

**FRY-TOP GAS RIGATO CROMATO SUPERCHROME (MOCA APPROVED), PIASTRA CM.36X51 (INCLUSA 1 TESTATA CHIUSURA PIANO MOD.TPA-7)**

**EN** Gas Fry-top grooved chromed griddle SUPERCHROME (Moca Approved), plate cm.36x51 (included 1 Head end filler strip mod.TPA-7) • **DE** Gas-griddleplatte gerillt hartverchromt SUPERCHROME (Moca Approved), platte cm.36x51 (inbegriffen 1 Abschluss-Element mod.TPA-7) • **FR** Plaque gaz nervurée chromée SUPERCHROME (Moca Approved), plaque cm.36x51 (inclus 1 Élément de jonction top mod.TPA-7) • **ES** Fry-top gas estriado cromado SUPERCHROME (Moca Approved), plancha cm.36x51 (incluida 1 Chapa de cierre para top mod.TPA-7)  
**cm. 40x 70,5x 28h**

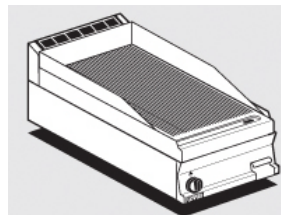

⚡ 7 kW  
6.020 kcal/h

**1.960,00**  
63 / 0,18

**FTLT-76G**  
18230651

**FRY-TOP GAS LISCIO, PIASTRA CM.56X51 (INCLUSA 1 TESTATA CHIUSURA PIANO MOD.TPA-7)**

**EN** Gas Fry-top smooth griddle, plate cm.56x51 (included 1 Head end filler strip mod.TPA-7) • **DE** Gas-griddleplatte glatt, platte cm.56x51 (inbegriffen 1 Abschluss-Element mod.TPA-7) • **FR** Plaque gaz lisse, plaque cm.56x51 (inclus 1 Élément de jonction top mod.TPA-7) • **ES** Fry-top gas liso, plancha cm.56x51 (incluida 1 Chapa de cierre para top mod.TPA-7)  
**cm. 60x 70,5x 28h**



⚡ 10,5 kW  
9.030 kcal/h

**1.772,00**  
68 / 0,26

**FTLT-76GS**  
18230654

**FRY-TOP GAS LISCIO CROMATO SUPERCHROME (MOCA APPROVED), PIASTRA CM.56X51 (INCLUSA 1 TESTATA CHIUSURA PIANO MOD.TPA-7)**

**EN** Gas Fry-top smooth chromed griddle SUPERCHROME (Moca Approved), plate cm.56x51 (included 1 Head end filler strip mod.TPA-7) • **DE** Gas-griddleplatte glatt hartverchromt SUPERCHROME (Moca Approved), platte cm.56x51 (inbegriffen 1 Abschluss-Element mod.TPA-7) • **FR** Plaque gaz lisse chromée SUPERCHROME (Moca Approved), plaque cm.56x51 (inclus 1 Élément de jonction top mod.TPA-7) • **ES** Fry-top gas liso cromado SUPERCHROME (Moca Approved), plancha cm.56x51 (incluida 1 Chapa de cierre para top mod.TPA-7)  
**cm. 60x 70,5x 28h**

⚡ 10,5 kW  
9.030 kcal/h

**2.208,00**  
68 / 0,26

**FTLRT-76G**  
18230652

**FRY-TOP GAS 1/2 RIGATO + 1/2 LISCIO, PIASTRA CM.56X51 (INCLUSA 1 TESTATA CHIUSURA PIANO MOD.TPA-7)**

**EN** Gas Fry-top 1/2 grooved + 1/2 smooth, plate cm.56x51 (included 1 Head end filler strip mod.TPA-7) • **DE** Gas-griddleplatte 1/2 gerillt + 1/2 glatt, platte cm.56x51 (inbegriffen 1 Abschluss-Element mod.TPA-7) • **FR** Plaque gaz 1/2 nervurée + 1/2 lisse, plaque cm.56x51 (inclus 1 Élément de jonction top mod.TPA-7) • **ES** Fry-top gas 1/2 estriado + 1/2 liso, plancha cm.56x51 (incluida 1 Chapa de cierre para top mod.TPA-7)  
**cm. 60x 70,5x 28h**



⚡ 10,5 kW  
9.030 kcal/h

**1.898,00**  
68 / 0,26

# FRY-TOP A GAS - TOP

MOD. \_\_\_\_\_  
COD. \_\_\_\_\_

DESCRIZIONE/DESCRIPTION/BEZEICHNUNG/DESCRIPTION/DESCRIPCIÓN  
DIMENSIONI/DIMENSIONS/ABMESSUNGEN/DIMENSIONS/DIMENSIONES

POTENZA/POWER/LEISTUNG/PUISSANCE/POTENCIA  
VOLTAGGIO/VOLTAGE/SPANNUNG/VOLTAGE/VOLTAJE

⚡ 10,5 kW  
9.030 kcal/h

PREZZO/PRICE €  
PREIS/PRIX/PRECIO €  
KG / M<sup>3</sup>

**FTLRT-76GS**  
18230655

**FRY-TOP GAS 1/2 RIGATO + 1/2 LISCIO CROMATO SUPERCHROME (MOCA APPROVED), PIASTRA CM.56X51 (INCLUSA 1 TESTATA CHIUSURA PIANO MOD.TPA-7)**  
EN Gas Fry-top 1/2 grooved + 1/2 smooth chromed griddle SUPERCHROME (Moca Approved), plate cm.56x51 (included 1 Head end filler strip mod. TPA-7) • DE Gas-griddleplatte 1/2 gerillt + 1/2 glatt hartverchromt SUPERCHROME (Moca Approved), platte cm.56x51 (inbegriffen 1 Abschluss-Element mod. TPA-7) • FR Plaque gaz 1/2 nervurée + 1/2 lisse chromée SUPERCHROME (Moca Approved), plaque cm.56x51 (inclus 1 Élément de jonction top mod.TPA-7) • ES Fry-top gas 1/2 estriado + 1/2 liso cromado SUPERCHROME (Moca Approved), plancha cm.56x51 (incluida 1 Chapa de cierre para top mod.TPA-7)  
**cm. 60x 70,5x 28h**



⚡ 10,5 kW  
9.030 kcal/h

**2.336,00**  
68 / 0,26



**FTRT-76G**  
18230653

**FRY-TOP GAS RIGATO, PIASTRA CM.56X51 (INCLUSA 1 TESTATA CHIUSURA PIANO MOD. TPA-7)**  
EN Gas Fry-top grooved griddle, plate cm.56x51 (included 1 Head end filler strip mod.TPA-7) • DE Gas-griddleplatte gerillt, platte cm.56x51 (inbegriffen 1 Abschluss-Element mod.TPA-7) • FR Plaque gaz nervurée, plaque cm.56x51 (inclus 1 Élément de jonction top mod.TPA-7) • ES Fry-top gas estriado, plancha cm.56x51 (incluida 1 Chapa de cierre para top mod. TPA-7)  
**cm. 60x 70,5x 28h**

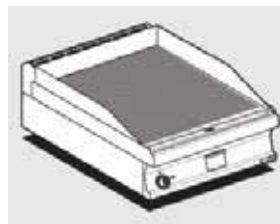

⚡ 10,5 kW  
9.030 kcal/h

**2.025,00**  
68 / 0,26



**FTRT-76GS**  
18230656

**FRY-TOP GAS RIGATO CROMATO SUPERCHROME (MOCA APPROVED), PIASTRA CM.56X51 (INCLUSA 1 TESTATA CHIUSURA PIANO MOD.TPA-7)**  
EN Gas Fry-top grooved chromed griddle SUPERCHROME (Moca Approved), plate cm.56x51 (included 1 Head end filler strip mod.TPA-7) • DE Gas-griddleplatte gerillt hartverchromt SUPERCHROME (Moca Approved), platte cm.56x51 (inbegriffen 1 Abschluss-Element mod.TPA-7) • FR Plaque gaz nervurée chromée SUPERCHROME (Moca Approved), plaque cm.56x51 (inclus 1 Élément de jonction top mod.TPA-7) • ES Fry-top gas estriado cromado SUPERCHROME (Moca Approved), plancha cm.56x51 (incluida 1 Chapa de cierre para top mod.TPA-7)  
**cm. 60x 70,5x 28h**

⚡ 10,5 kW  
9.030 kcal/h

**2.464,00**  
68 / 0,26



**FTLT-78G**  
18230851

**FRY-TOP GAS LISCIO, PIASTRA CM.76X51 - 2 ZONE DI COTTURA (INCLUSA 1 TESTATA CHIUSURA PIANO MOD.TPA-7)**  
EN Gas Fry-top smooth griddle, plate cm.76x51 - 2 cooking areas (included 1 Head end filler strip mod. TPA-7) • DE Gas-griddleplatte glatt, platte cm.76x51 - 2 Heizzonen (inbegriffen 1 Abschluss-Element mod. TPA-7) • FR Plaque gaz lisse, plaque cm.76x51 - 2 zones de cuisson (inclus 1 Élément de jonction top mod. TPA-7) • ES Fry-top gas liso, plancha cm.76x51 - 2 zonas de cocción (incluida 1 Chapa de cierre para top mod.TPA-7)  
**cm. 80x 70,5x 28h**



⚡ 14 kW  
12.040 kcal/h

**2.611,00**  
108 / 0,35

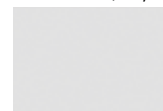

MOD. \_\_\_\_\_  
COD. \_\_\_\_\_

DESCRIZIONE/DESCRIPTION/BEZEICHNUNG/DESCRIPTION/DESCRIPCIÓN  
DIMENSIONI/DIMENSIONS/ABMESSUNGEN/DIMENSIONS/DIMENSIONES

POTENZA/POWER/LEISTUNG/PUISSANCE/POTENCIA  
VOLTAGGIO/VOLTAGE/SPANNUNG/VOLTAGE/VOLTAJE

14 kW  
12.040 kcal/h

PREZZO/PRICE €  
PREIS/PRIX/PRECIO €  
KG / M<sup>3</sup>

**FTLT-78GS**  
18230854

**FRY-TOP GAS LISCIO CROMATO SUPERCHROME (MOCA APPROVED), PIASTRA CM.76X51 - 2 ZONE DI COTTURA (INCLUSA 1 TESTATA CHIUSURA PIANO MOD.TPA-7)**  
EN Gas Fry-top smooth chromed griddle SUPERCHROME (Moca Approved), plate cm.76x51 - 2 cooking areas (included 1 Head end filler strip mod. TPA-7) • DE Gas-griddleplatte glatt hartverchromt SUPERCHROME (Moca Approved), platte cm.76x51 - 2 Heizzonen (inbegriffen 1 Abschluss-Element mod. TPA-7) • FR Plaque gaz lisse chromée SUPERCHROME (Moca Approved), plaque cm.76x51 - 2 zones de cuisson (inclus 1 Élément de jonction top mod.TPA-7) • ES Fry-top gas liso cromado SUPERCHROME (Moca Approved), plancha cm.76x51 - 2 zonas de cocción (incluida 1 Chapa de cierre para top mod.TPA-7)  
**cm. 80x 70,5x 28h**



14 kW  
12.040 kcal/h

**3.253,00**  
108 / 0,35

**FTRLT-78G**  
18230852

**FRY-TOP GAS 1/2 RIGATO + 1/2 LISCIO, PIASTRA CM.76X51 - 2 ZONE DI COTTURA (INCLUSA 1 TESTATA CHIUSURA PIANO MOD. TPA-7)**  
EN Gas Fry-top 1/2 grooved + 1/2 smooth, plate cm.76x51 - 2 cooking areas (included 1 Head end filler strip mod.TPA-7) • DE Gas-griddleplatte 1/2 gerillt + 1/2 glatt, platte cm.76x51 - 2 Heizzonen (inbegriffen 1 Abschluss-Element mod.TPA-7) • FR Plaque gaz 1/2 nervurée + 1/2 lisse, plaque cm.76x51 - 2 zones de cuisson (inclus 1 Élément de jonction top mod.TPA-7) • ES Fry-top gas 1/2 estriado + 1/2 liso, plancha cm.76x51 - 2 zonas de cocción (incluida 1 Chapa de cierre para top mod.TPA-7)  
**cm. 80x 70,5x 28h**



14 kW  
12.040 kcal/h

**2.763,00**  
108 / 0,35

**FTRLT-78GS**  
18230855

**FRY-TOP GAS 1/2 RIGATO + 1/2 LISCIO CROMATO SUPERCHROME (MOCA APPROVED), PIASTRA CM.76X51 - 2 ZONE DI COTTURA (INCLUSA 1 TESTATA CHIUSURA PIANO MOD.TPA-7)**  
EN Gas Fry-top 1/2 grooved + 1/2 smooth chromed griddle SUPERCHROME (Moca Approved), plate cm.76x51 - 2 cooking areas (included 1 Head end filler strip mod.TPA-7) • DE Gas-griddleplatte 1/2 gerillt + 1/2 glatt hartverchromt SUPERCHROME (Moca Approved), platte cm.76x51 - 2 Heizzonen (inbegriffen 1 Abschluss-Element mod.TPA-7) • FR Plaque gaz 1/2 nervurée + 1/2 lisse chromée SUPERCHROME (Moca Approved), plaque cm.76x51 - 2 zones de cuisson (inclus 1 Élément de jonction top mod.TPA-7) • ES Fry-top gas 1/2 estriado + 1/2 liso cromado SUPERCHROME (Moca Approved), plancha cm.76x51 - 2 zonas de cocción (incluida 1 Chapa de cierre para top mod.TPA-7)  
**cm. 80x 70,5x 28h**



14 kW  
12.040 kcal/h

**3.405,00**  
108 / 0,35

**FVRT-78G**  
18230853

**FRY-TOP GAS RIGATO, PIASTRA CM.76X51 - 2 ZONE DI COTTURA (INCLUSA 1 TESTATA CHIUSURA PIANO MOD.TPA-7)**  
EN Gas Fry-top grooved griddle, plate cm.76x51 - 2 cooking areas (included 1 Head end filler strip mod.TPA-7) • DE Gas-griddleplatte gerillt, platte cm.76x51 - 2 Heizzonen (inbegriffen 1 Abschluss-Element mod.TPA-7) • FR Plaque gaz nervurée, plaque cm.76x51 - 2 zones de cuisson (inclus 1 Élément de jonction top mod.TPA-7) • ES Fry-top gas estriado, plancha cm.76x51 - 2 zonas de cocción (incluida 1 Chapa de cierre para top mod. TPA-7)  
**cm. 80x 70,5x 28h**



14 kW  
12.040 kcal/h

**2.915,00**  
108 / 0,35

# FRY-TOP A GAS - TOP

MOD. \_\_\_\_\_  
COD. \_\_\_\_\_

DESCRIZIONE/DESCRIPTION/BEZEICHNUNG/DESCRIPTION/DESCRIPCIÓN  
DIMENSIONI/DIMENSIONS/ABMESSUNGEN/DIMENSIONS/DIMENSIONES

POTENZA/POWER/LEISTUNG/PUISSANCE/POTENCIA  
VOLTAGGIO/VOLTAGE/SPANNUNG/VOLTAGE/VOLTAJE

⚡ kW  
kcal/h

⚡ kw  
V~  
Hz

PREZZO/PRICE €  
PREIS/PRIX/PRECIO €  
KG / M<sup>3</sup>

**FTRT-78GS**  
18230856

**FRY-TOP GAS RIGATO CROMATO SUPERCHROME (MOCA APPROVED), PIASTRA CM.76X51 - 2 ZONE DI COTTURA (INCLUSA 1 TESTATA CHIUSURA PIANO MOD.TPA-7)**

**EN** Gas Fry-top grooved chromed griddle SUPERCHROME (Moca Approved), plate cm.76x51 - 2 cooking areas (included 1 Head end filler strip mod. TPA-7) • **DE** Gas-griddleplatte gerillt hartverchromt SUPERCHROME (Moca Approved), platte cm.76x51 - 2 Heizzonen (inbegriffen 1 Abschluss-Element mod.TPA-7) • **FR** Plaque gaz nervurée chromée SUPERCHROME (Moca Approved), plaque cm.76x51 - 2 zones de cuisson (inclus 1 Élément de jonction top mod.TPA-7) • **ES** Fry-top gas estriado cromado SUPERCHROME (Moca Approved), plancha cm.76x51 - 2 zonas de cocción (incluida 1 Chapa de cierre para top mod. TPA-7)

**cm. 80x 70,5x 28h**



⚡ 14 kW  
12.040 kcal/h

**3.557,00**  
108 / 0,35



**FTLT-712G**  
18231251

**FRY-TOP GAS LISCIO, PIASTRA CM.116X51 - 2 ZONE DI COTTURA (INCLUSA 1 TESTATA CHIUSURA PIANO MOD.TPA-7)**

**EN** Gas Fry-top smooth griddle, plate cm.116x51 - 2 cooking areas (included 1 Head end filler strip mod. TPA-7) • **DE** Gas-griddleplatte glatt, platte cm.116x51 - 2 Heizzonen (inbegriffen 1 Abschluss-Element mod. TPA-7) • **FR** Plaque gaz lisse, plaque cm.116x51 - 2 zones de cuisson (inclus 1 Élément de jonction top mod. TPA-7) • **ES** Fry-top gas liso, plancha cm.116x51 - 2 zonas de cocción (incluida 1 Chapa de cierre para top mod. TPA-7)

**cm. 120x 70,5x 28h**



⚡ 21 kW  
18.060 kcal/h

**3.455,00**  
120 / 0,51



**FTLT-712GS**  
18231254

**FRY-TOP GAS LISCIO CROMATO SUPERCHROME (MOCA APPROVED), PIASTRA CM.116X51 - 2 ZONE DI COTTURA (INCLUSA 1 TESTATA CHIUSURA PIANO MOD.TPA-7)**

**EN** Gas Fry-top smooth chromed griddle SUPERCHROME (Moca Approved), plate cm.116x51 - 2 cooking areas (included 1 Head end filler strip mod. TPA-7) • **DE** Gas-griddleplatte glatt hartverchromt SUPERCHROME (Moca Approved), platte cm.116x51 - 2 Heizzonen (inbegriffen 1 Abschluss-Element mod. TPA-7) • **FR** Plaque gaz lisse chromée SUPERCHROME (Moca Approved), plaque cm.116x51 - 2 zones de cuisson (inclus 1 Élément de jonction top mod.TPA-7) • **ES** Fry-top gas liso cromado SUPERCHROME (Moca Approved), plancha cm.116x51 - 2 zonas de cocción (incluida 1 Chapa de cierre para top mod. TPA-7)

**cm. 120x 70,5x 28h**

⚡ 21 kW  
18.060 kcal/h

**4.121,00**  
120 / 0,51



**FTLRT-712G**  
18231252

**FRY-TOP GAS 1/2 RIGATO + 1/2 LISCIO, PIASTRA CM.116X51 - 2 ZONE DI COTTURA (INCLUSA 1 TESTATA CHIUSURA PIANO MOD. TPA-7)**

**EN** Gas Fry-top 1/2 grooved + 1/2 smooth, plate cm.116x51 - 2 cooking areas (included 1 Head end filler strip mod.TPA-7) • **DE** Gas-griddleplatte 1/2 gerillt + 1/2 glatt, platte cm.116x51 - 2 Heizzonen (inbegriffen 1 Abschluss-Element mod.TPA-7) • **FR** Plaque gaz 1/2 nervurée + 1/2 lisse, plaque cm.116x51 - 2 zones de cuisson (inclus 1 Élément de jonction top mod.TPA-7) • **ES** Fry-top gas 1/2 estriado + 1/2 liso, plancha cm.116x51 - 2 zonas de cocción (incluida 1 Chapa de cierre para top mod. TPA-7)

**cm. 120x 70,5x 28h**

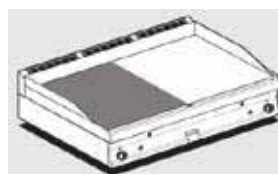

⚡ 21 kW  
18.060 kcal/h

**3.640,00**  
120 / 0,51





MOD. \_\_\_\_\_  
COD. \_\_\_\_\_

DESCRIZIONE/DESCRIPTION/BEZEICHNUNG/DESCRIPTION/DESCRIPCIÓN  
DIMENSIONI/DIMENSIONS/ABMESSUNGEN/DIMENSIONS/DIMENSIONES

POTENZA/POWER/LEISTUNG/PUISSANCE/POTENCIA  
VOLTAGGIO/VOLTAGE/SPANNUNG/VOLTAGE/VOLTAJE

⚡ 21 kW  
18.060 kcal/h

PREZZO/PRICE €  
120 / 0,51  
KG / M<sup>3</sup>

**FTLRT-712GS FRY-TOP GAS 1/2 RIGATO + 1/2 LISCIO CROMATO SUPERCHROME (MOCA APPROVED), PIASTRA CM.116X51 - 2 ZONE DI COTTURA (INCLUSA 1 TESTATA CHIUSURA PIANO MOD.TPA-7)**

18231255

**EN** Gas Fry-top 1/2 grooved + 1/2 smooth chromed griddle SUPERCHROME (Moca Approved), plate cm.116x51 - 2 cooking areas (included 1 Head end filler strip mod.TPA-7) • **DE** Gas-griddleplatte 1/2 gerillt + 1/2 glatt hartverchromt SUPERCHROME (Moca Approved), platte cm.116x51 - 2 Heizzonen (inbegriffen 1 Abschluss-Element mod.TPA-7) • **FR** Plaque gaz 1/2 nervurée + 1/2 lisse chromée SUPERCHROME (Moca Approved), plaque cm.116x51 - 2 zones de cuisson (inclus 1 Élément de jonction top mod.TPA-7) • **ES** Fry-top gas 1/2 estriado + 1/2 liso cromado SUPERCHROME (Moca Approved), plancha cm.116x51 - 2 zonas de cocción (incluida 1 Chapa de cierre para top mod.TPA-7)  
**cm. 120x 70,5x 28h**



⚡ 21 kW  
18.060 kcal/h

**4.272,00**  
120 / 0,51



**FRT-712G FRY-TOP GAS RIGATO, PIASTRA CM.116X51 - 2 ZONE DI COTTURA (INCLUSA 1 TESTATA CHIUSURA PIANO MOD.TPA-7)**

18231253

**EN** Gas Fry-top grooved griddle, plate cm.116x51 - 2 cooking areas (included 1 Head end filler strip mod.TPA-7) • **DE** Gas-griddleplatte gerillt, platte cm.116x51 - 2 Heizzonen (inbegriffen 1 Abschluss-Element mod.TPA-7) • **FR** Plaque gaz nervurée, plaque cm.116x51 - 2 zones de cuisson (inclus 1 Élément de jonction top mod.TPA-7) • **ES** Fry-top gas estriado, plancha cm.116x51 - 2 zonas de cocción (incluida 1 Chapa de cierre para top mod.TPA-7)  
**cm. 120x 70,5x 28h**

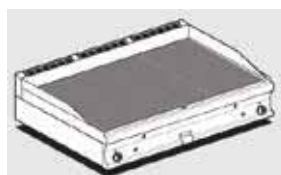

⚡ 21 kW  
18.060 kcal/h

**3.827,00**  
120 / 0,51



**FRT-712GS FRY-TOP GAS RIGATO CROMATO SUPERCHROME (MOCA APPROVED), PIASTRA CM.116X51 - 2 ZONE DI COTTURA (INCLUSA 1 TESTATA CHIUSURA PIANO MOD.TPA-7)**

18231256

**EN** Gas Fry-top grooved chromed griddle SUPERCHROME (Moca Approved), plate cm.116x51 - 2 cooking areas (included 1 Head end filler strip mod.TPA-7) • **DE** Gas-griddleplatte gerillt hartverchromt SUPERCHROME (Moca Approved), platte cm.116x51 - 2 Heizzonen (inbegriffen 1 Abschluss-Element mod.TPA-7) • **FR** Plaque gaz nervurée chromée SUPERCHROME (Moca Approved), plaque cm.116x51 - 2 zones de cuisson (inclus 1 Élément de jonction top mod.TPA-7) • **ES** Fry-top gas estriado cromado SUPERCHROME (Moca Approved), plancha cm.116x51 - 2 zonas de cocción (incluida 1 Chapa de cierre para top mod.TPA-7)  
**cm. 120x 70,5x 28h**

⚡ 21 kW  
18.060 kcal/h

**4.469,00**  
120 / 0,51



**FTL-712G3 FRY-TOP GAS LISCIO, PIASTRA CM.116X51 - 3 ZONE DI COTTURA (INCLUSA 1 TESTATA CHIUSURA PIANO MOD.TPA-7)**

18231258

**EN** Gas Fry-top smooth griddle, plate cm.116x51 - 3 cooking areas (included 1 Head end filler strip mod.TPA-7) • **DE** Gas-griddleplatte glatt, platte cm.116x51 - 3 Heizzonen (inbegriffen 1 Abschluss-Element mod.TPA-7) • **FR** Plaque gaz lisse, plaque cm.116x51 - 3 zones de cuisson (inclus 1 Élément de jonction top mod.TPA-7) • **ES** Fry-top gas liso, plancha cm.116x51 - 3 zonas de cocción (incluida 1 Chapa de cierre para top mod.TPA-7)  
**cm. 120x 70,5x 28h**



⚡ 21 kW  
18.060 kcal/h

**3.753,00**  
120 / 0,51



MOD. \_\_\_\_\_  
COD. \_\_\_\_\_

DESCRIZIONE/DESCRIPTION/BEZEICHNUNG/DESCRIPTION/DESCRIPCIÓN  
DIMENSIONI/DIMENSIONS/ABMESSUNGEN/DIMENSIONS/DIMENSIONES

POTENZA/POWER/LEISTUNG/PUISSANCE/POTENCIA  
VOLTAGGIO/VOLTAGE/SPANNUNG/VOLTAGE/VOLTAJE

⚡ 21 kW  
18.060 kcal/h

PREZZO/PRICE €  
120 / 0,51  
KG / M<sup>3</sup>

**FRTL-712GS3 FRY-TOP GAS LISCIO CROMATO SUPERCHROME (MOCA APPROVED), PIASTRA CM.116X51 - 3 ZONE DI COTTURA (INCLUSA 1 TESTATA CHIUSURA PIANO MOD.TPA-7)**

1823125E

EN Gas Fry-top smooth chromed griddle SUPERCHROME (Moca Approved), plate cm.116x51 - 3 cooking areas (included 1 Head end filler strip mod. TPA-7) • DE Gas-griddleplatte glatt hartverchromt SUPERCHROME (Moca Approved), platte cm.116x51 - 3 Heizzonen (inbegriffen 1 Abschluss-Element mod. TPA-7) • FR Plaque gaz lisse chromée SUPERCHROME (Moca Approved), plaque cm.116x51 - 3 zones de cuisson (inclus 1 Élément de jonction top mod.TPA-7) • ES Fry-top gas liso cromado SUPERCHROME (Moca Approved), plancha cm.116x51 - 3 zonas de cocción (incluida 1 Chapa de cierre para top mod.TPA-7)  
**cm. 120x 70,5x 28h**



⚡ 21 kW  
18.060 kcal/h

**4.385,00**  
120 / 0,51

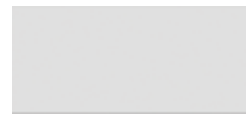

**FTLRT-712G3 FRY-TOP GAS 1/3 RIGATO + 2/3 LISCIO, PIASTRA CM.116X51 - 3 ZONE DI COTTURA (INCLUSA 1 TESTATA CHIUSURA PIANO MOD. TPA-7)**

1823125C

EN Gas Fry-top 1/3 grooved + 2/3 smooth, plate cm.116x51 - 3 cooking areas (included 1 Head end filler strip mod.TPA-7) • DE Gas-griddleplatte 1/3 gerillt + 2/3 glatt, platte cm.116x51 - 3 Heizzonen (inbegriffen 1 Abschluss-Element mod.TPA-7) • FR Plaque gaz 1/3 nervurée + 2/3 lisse, plaque cm.116x51 - 3 zones de cuisson (inclus 1 Élément de jonction top mod.TPA-7) • ES Fry-top gas 1/3 estriado + 2/3 liso, plancha cm.116x51 - 3 zonas de cocción (incluida 1 Chapa de cierre para top mod.TPA-7)  
**cm. 120x 70,5x 28h**



⚡ 21 kW  
18.060 kcal/h

**3.849,00**  
120 / 0,51



**FTLRT-712GS3 FRY-TOP GAS 1/3 RIGATO + 2/3 LISCIO CROMATO SUPERCHROME (MOCA APPROVED), PIASTRA CM.116X51 - 3 ZONE DI COTTURA (INCLUSA 1 TESTATA CHIUSURA PIANO MOD.TPA-7)**

1823125F

EN Gas Fry-top 1/3 grooved + 2/3 smooth chromed griddle SUPERCHROME (Moca Approved), plate cm.116x51 - 3 cooking areas (included 1 Head end filler strip mod.TPA-7) • DE Gas-griddleplatte 1/3 gerillt + 2/3 glatt hartverchromt SUPERCHROME (Moca Approved), platte cm.116x51 - 3 Heizzonen (inbegriffen 1 Abschluss-Element mod.TPA-7) • FR Plaque gaz 1/3 nervurée + 2/3 lisse chromée SUPERCHROME (Moca Approved), plaque cm.116x51 - 3 zones de cuisson (inclus 1 Élément de jonction top mod.TPA-7) • ES Fry-top gas 1/3 estriado + 2/3 liso cromado SUPERCHROME (Moca Approved), plancha cm.116x51 - 3 zonas de cocción (incluida 1 Chapa de cierre para top mod.TPA-7)  
**cm. 120x 70,5x 28h**

⚡ 21 kW  
18.060 kcal/h

**4.535,00**  
120 / 0,51



**CWKT-74ET GRIGLIA CONTACT - COTTURA DIRETTA SU RESISTENZA IN ACCIAIO INOX CM. 27X43 RIBALTABILE (INCLUSA 1 TESTATA CHIUSURA PIANO MOD.TPA-7)**

18080431

EN CONTACT Grill threephase - rotatable stainless steel grill cm. 27x43 (included 1 Head end filler strip mod.TPA-7) • DE Wurstbrater dreiphasig KONTAKT - Drehbaren Heizelement aus Edelstahl cm. 27x43 (inbegriffen 1 Abschluss-Element mod.TPA-7) • FR Grillade triphase CONTACT - Grille inox rotatif cm 27x43 (inclus 1 Élément de jonction top mod.TPA-7) • ES Parrilla trifásico CONTACT - Parrilla giratoria de acero inox cm 27x43 (incluida 1 Chapa de cierre para top mod.TPA-7)  
**cm. 40x 70,5x 28h**



⚡ 4,08 KW  
400V-3N  
50/60 Hz

**2.343,00**  
55 / 0,18

# GRIGLIE ELETTRICHE - TOP

MOD. \_\_\_\_\_  
COD. \_\_\_\_\_

DESCRIZIONE / DESCRIPTION / BEZEICHNUNG / DESCRIPTION / DESCRIPCIÓN  
DIMENSIONI / DIMENSIONS / ABMESSUNGEN / DIMENSIONS / DIMENSIONES

POTENZA / POWER / LEISTUNG / PUISSANCE / POTENCIA  
VOLTAGGIO / VOLTAGE / SPANNUNG / VOLTAGE / VOLTAJE

⚡ kcal/h    ⚡ kW  
V~    Hz

PREZZO / PRICE €  
PREIS / PRIX / PRECIO €  
KG / M<sup>3</sup>

**CWKT-78ET**  
18080831

**GRIGLIA CONTACT - COTTURA DIRETTA SU RESISTENZA IN ACCIAIO INOX CM. 55X43 RIBALTABILE - 2 ZONE COTTURA (INCLUSA 1 TESTATA CHIUSURA PIANO MOD.TPA-7)**  
**EN** CONTACT Grill threephase - rotatable stainless steel grill cm. 55x43 - 2 cooking areas (included 1 Head end filler strip mod.TPA-7) • **DE** Wurstbrater dreiphasig KONTAKT - Drehbaren Heizelement aus Edelstahl cm. 55x43 - 2 Heizzonen (inbegriffen 1 Abschluss-Element mod.TPA-7) • **FR** Grillade triphase CONTACT - Grille inox rotatif cm 55x43 - 2 zones de cuisson (inclus 1 Élément de jonction top mod.TPA-7) • **ES** Parrilla trifásico CONTACT - Parrilla giratoria de acero inox cm 55x43 - 2 zonas de cocción (incluida 1 Chapa de cierre para top mod.TPA-7)  
**cm. 80x 70,5x 28h**

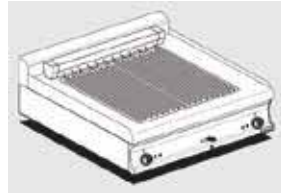

⚡ 8,16 kW    **3.163,00**  
400V~3N    85 / 0,35  
50/60 Hz

**CWT-74ET**  
18080430

**GRIGLIA TRIFASE GRIGLIA IN ACCIAIO INOX CM. 38X52 REGOLABILE (INCLUSA 1 TESTATA CHIUSURA PIANO MOD.TPA-7)**  
**EN** Grill threephase - Stainless steel grill cm. 38x52 (included 1 Head end filler strip mod.TPA-7) • **DE** Wurstbrater dreiphasig - Einstellbarer Rost aus Nirosta cm. 38x52 (inbegriffen 1 Abschluss-Element mod.TPA-7) • **FR** Grillade triphase - Grille inox cm 38x52 (inclus 1 Élément de jonction top mod.TPA-7) • **ES** Parrilla trifásico - Parrilla de acero inox regulable cm 38x52 (incluida 1 Chapa de cierre para top mod.TPA-7)  
**cm. 40x 70,5x 28h**



⚡ 6 kW    **1.659,00**  
400V~3N    57 / 0,18  
230V~3  
50/60 Hz

**CWT-78ET**  
18080830

**GRIGLIA TRIFASE N. 2 GRIGLIE IN ACCIAIO INOX CM. 38X52 REGOLABILI 2 ZONE DI COTTURA (INCLUSA 1 TESTATA CHIUSURA PIANO MOD.TPA-7)**  
**EN** Grill threephase - N. 2 Stainless steel grill cm. 38x52. 2 cooking areas (included 1 Head end filler strip mod.TPA-7) • **DE** Wurstbrater dreiphasig - N. 2 einstellbare Roste aus Nirosta cm. 38x52 - 2 Heizzonen (inbegriffen 1 Abschluss-Element mod.TPA-7) • **FR** Grillade triphase - N. 2 grilles réglables en acier inox cm. 38x52 - 2 zones de cuisson (inclus 1 Élément de jonction top mod.TPA-7) • **ES** Parrilla trifásico - N. 2 Parrillas de acero inox regulable cm 38x52 - 2 zonas de cocción (incluida 1 Chapa de cierre para top mod.TPA-7)  
**cm. 80x 70,5x 28h**



⚡ 12 kW    **2.505,00**  
400V~3N    87 / 0,35  
230V~3  
50/60 Hz

**CWT-74G**  
18250450

**GRIGLIA GAS-PIETRALAVICA GRIGLIA IN ACCIAIO INOX CM. 38X52 REGOLABILE (INCLUSA 1 TESTATA CHIUSURA PIANO MOD.TPA-7)**  
**EN** Charcoal grill gas - Stainless steel grill cm. 38x52 (included 1 Head end filler strip mod.TPA-7) • **DE** Gas-Lavasteingrill - Einstellbarer Rost aus Nirosta cm. 38x52 (inbegriffen 1 Abschluss-Element mod.TPA-7) • **FR** Grille à gaz en pierre de lave - Grille inox cm 38x52 (inclus 1 Élément de jonction top mod.TPA-7) • **ES** Parrilla a gas piedra lávica - Parrilla de acero inox regulable cm 38x52 (incluida 1 Chapa de cierre para top mod.TPA-7)  
**cm. 40x 70,5x 28h**



⚡ 9 kW    **1.804,00**  
7.740 kcal/h    56 / 0,21

# GRIGLIE PIETRA LAVICA A GAS - TOP

MOD. \_\_\_\_\_  
COD. \_\_\_\_\_

DESCRIZIONE/DESCRIPTION/BEZEICHNUNG/DESCRIPTION/DESCRIPCIÓN  
DIMENSIONI/DIMENSIONS/ABMESSUNGEN/DIMENSIONS/DIMENSIONES

POTENZA/POWER/LEISTUNG/PUISSANCE/POTENCIA  
VOLTAGGIO/VOLTAGE/SPANNUNG/VOLTAGE/VOLTAJE

⚡ kW kcal/h  
⚡ kW kcal/h  
V~ Hz

PREZZO/PRICE €  
PREIS/PRIX/PRECIO €  
KG / M<sup>3</sup>

**CWT-78G**  
18250850

**GRIGLIA GAS-PIETRALAVICA N. 2 GRIGLIE IN ACCIAIO INOX CM. 38X52 REGOLABILI 2 ZONE DI COTTURA (INCLUSA 1 TESTATA CHIUSURA PIANO MOD.TPA-7)**  
**EN** Charcoal grill gas - N. 2 Stainless steel grill cm. 38x52 2 cooking areas (included 1 Head end filler strip mod.TPA-7) • **DE** Gas-Lavasteingrill - N. 2 einstellbare Roste aus Nirosta cm. 38x52 - 2 Heizzonen (inbegriffen 1 Abschluss-Element mod.TPA-7) • **FR** Grille a gaz en pierre de lave - N. 2 grilles réglables en acier inox cm. 38x52 - 2 zones de cuisson (inclus 1 Élément de jonction top mod.TPA-7) • **ES** Parrilla a gas piedra lávica - N. 2 Parrillas de acero inox regulable cm 38x52 - 2 zonas de cocción (incluida 1 Chapa de cierre para top mod. TPA-7)  
**cm. 80x 70,5x 28h**



⚡ 18 kW  
15.480 kcal/h **2.814,00**  
97 / 0,40

**F2/8T-74ET**  
18090432

**FRIGGITRICE TRIFASE LT. 8+8 2 VASCHE CM. 14,8X35,5X22,5H - 2 CESTI CM. 12X29X11,5H - FILTRO E COPERCHIO VASCA. PRODUZIONE PATATE: 12 KG/H (INCLUSA 1 TESTATA CHIUSURA PIANO MOD.TPA-7)**  
**EN** Fryer threephase 8+8 lts - 2 Bowls cm. 14,8x35,5x22,5h - 2 baskets cm. 12x29x11,5h. Sieve and lid for pan. Production: 12 kg/h (included 1 Head end filler strip mod.TPA-7) • **DE** Friteuse dreiphasig lt. 8+8 - 2 Becken cm. 14,8x35,5x22,5h - 2 Korb cm. 12x29x11,5h. Einlegesieb und Deckel für Becken. Pommes frites: 12 kg/h (inbegriffen 1 Abschluss-Element mod.TPA-7) • **FR** Friteuse triphase lt. 8+8 - 2 Cuve cm. 14,8x35,5x22,5h - 2 Panier cm. 12x29x11,5h. Filtre, couvercle pour cuve. Production de pommes frites: 12 kg/h (inclus 1 Élément de jonction top mod. TPA-7) • **ES** Freidoras trifásico 8+8 lt. - 2Cuba cm. 14,8x35,5x22,5h - 2 cesta cm. 12x29x11,5h. Filtro y tapa para cuba. Prod. patatas: 12 Kg/h (incluida 1 Chapa de cierre para top mod.TPA-7)  
**cm. 40x 70,5x 28h**



⚡ 12 kW  
400V~3N 2.514,00  
230V~3 50 / 0,18  
50/60 Hz

**F13T-74ET**  
18090430

**FRIGGITRICE TRIFASE LT. 13 VASCA CM. 30,5X34X22,5H - 1 CESTO CM. 28X29X10H FILTRO E COPERCHIO VASCA - PRODUZIONE PATATE: 10 KG/H (INCLUSA 1 TESTATA CHIUSURA PIANO MOD.TPA-7)**  
**EN** Fryer threephase 13 lts - Bowl cm. 30,5x34x22,5h 1 basket cm. 28x29x10h - Sieve and lid for pan Production: 10 kg/h (included 1 Head end filler strip mod.TPA-7) • **DE** Friteuse dreiphasig lt. 13 - Becken cm. 30,5x34x22,5h - 1 Korb cm. 28x29x10h - Einlegesieb und Deckel für Becken - Pommes frites: 10 kg/h (inbegriffen 1 Abschluss-Element mod.TPA-7) • **FR** Friteuse triphase lt. 13 - Cuve cm. 30,5x34x22,5h - 1 Panier cm. 28x29x10h - Filtre, couvercle pour cuve Production de pommes frites: 10 kg/h (inclus 1 Élément de jonction top mod.TPA-7) • **ES** Freidoras trifásico 13 lt. - Cuba cm. 30,5x34x22,5h - 1 cesta cm. 28x29x10h - Filtro y tapa para cuba. Prod. patatas: 10 Kg/h (incluida 1 Chapa de cierre para top mod.TPA-7)  
**cm. 40x 70,5x 28h**



⚡ 11,95 kW  
400V~3N 1.780,00  
50/60 Hz 48 / 0,18



Le immagini presentate non sono vincolanti. La ditta si riserva di apportare modifiche senza preavviso. • The pictures are purely representative. The manufacturer reserves the right to modify the technical data and models without previous notice. • Les images

LO

présentées ne nous engagent pas. La Société se réserve le droit d'apporter tout modification sans préavis. • Die dargestellten Abbildungen sind nicht verbindlich. Technische Änderungen vorbehalten. • Las imágenes presentadas no son vinculantes. El Fabricante se reserva el derecho de modificar sus productos sin previo aviso.

01/20

217



# FRIGGITRICI ELETTRICHE - TOP

MOD. \_\_\_\_\_  
COD. \_\_\_\_\_

DESCRIZIONE/DESCRIPTION/BEZEICHNUNG/DESCRIPTION/DESCRIPCIÓN  
DIMENSIONI/DIMENSIONS/ABMESSUNGEN/DIMENSIONS/DIMENSIONES

POTENZA/POWER/LEISTUNG/PUISSANCE/POTENCIA  
VOLTAGGIO/VOLTAGE/SPANNUNG/VOLTAGE/VOLTAJE

⚡ kW kcal/h  
⚡ kW V~ Hz

PREZZO/PRICE €  
PREIS/PRIX/PRECIO €  
KG / M<sup>3</sup>

**F2/13T-78ET FRIGGITRICE TRIFASE LT. 13+13 2 VASCHE CM. 30,5X34X22,5H - 2 CESTI CM. 28X29X10H**

18090830

**2 FILTRI E COPERCHI VASCHE - PRODUZIONE PATATE: 20 KG/H (INCLUSA 1 TESTATA CHIUSURA PIANO MOD.TPA-7)**

**EN** Fryer threephase 13+13 lts - 2 pans cm. 30,5x34x22,5h 2 baskets cm. 28x29x10h - 2 sieves and lids for pan Production: 20 kg/h (included 1 Head end filler strip mod.TPA-7) • **DE** Friteuse dreiphasig lt. 13+13 - 2 Becken cm. 30,5x34x22,5h 2 Körbe cm. 28x29x10h - Einlegesieb und Deckel für Becken - Pommes frites: 20 kg/h (inbegriffen 1 Abschluss-Element mod.TPA-7) • **FR** Friteuse triphase lt. 13+13 - 2 cuves cm. 30,5x34x22,5h 2 paniers cm. 28x29x10h - 2 filtres, couvercles pour cuve Production de pommes frites: 20 kg/h (inclus 1 Élément de jonction top mod.TPA-7) • **ES** Freidoras trifásico 13+13 lt. - 2 cubas cm. 30,5x34x22,5h - 2 cestas cm. 28x29x10h - 2 filtros y tapas para cubas Prod. patatas: 20 Kg/h (incluida 1 Chapa de cierre para top mod.TPA-7)  
**cm. 80x 70,5x 28h**



⚡ 23,9 kW 2.821,00  
400V~3N 75 / 0,35  
50/60 Hz

**F2/8T-74G FRIGGITRICE GAS LT. 8+8 - 2 VASCHE CM. 15X35X23H 2 CESTI CM. 12X30X9,5H.**

18260452

**FILTRO E COPERCHIO VASCA. PROD. PATATE: 12 KG/H (INCLUSA 1 TESTATA CHIUSURA PIANO MOD.TPA-7)**

**EN** Gas Fryer 8+8 lts - 2 pans cm. 15x35x23h 2 baskets cm. 12x30x9,5h. Sieve and lid for pan. Production: 12 kg/h (included 1 Head end filler strip mod.TPA-7) • **DE** Gas-Friteuse lt. 8+8 - 2 Becken cm. 15x35x23h 2 Körbe cm. 12x30x9,5h. Einlegesieb und Deckel für Becken. Pommes frites: 12 kg/h (inbegriffen 1 Abschluss-Element mod.TPA-7) • **FR** Friteuse à gaz lt. 8+8 - 2 cuves cm. 15x35x23h 2 paniers cm. 12x30x9,5h. Filtre, couvercle pour cuve. Production de pommes frites: 12 kg/h (inclus 1 Élément de jonction top mod.TPA-7) • **ES** Freidoras a gas 8+8 lt. - 2 cubas cm. 15x35x23h 2 cestas cm. 12x30x9,5h. Filtro y tapa para cuba. Prod. patatas: 12 Kg/h (incluida 1 Chapa de cierre para top mod.TPA-7)  
**cm. 40x 70,5x 28h**



⚡ 9 kW 2.891,00  
7.740 kcal/h 50 / 0,18

**F13T-74G FRIGGITRICE GAS LT. 13 - VASCA CM. 31,5X34,5X22,5H 1 CESTO CM. 28X29X10H**

18260450

**- FILTRO E COPERCHIO VASCA. PROD. PATATE: 10 KG/H (INCLUSA 1 TESTATA CHIUSURA PIANO MOD.TPA-7)**

**EN** Gas Fryer 13 lts - Bowl cm. 31,5x34,5x22,5h - 1 basket cm. 28x29x10h - Sieve and lid for pan Production: 10 kg/h (included 1 Head end filler strip mod.TPA-7) • **DE** Gas-Friteuse lt. 13 - Becken cm. 31,5x34,5x22,5h - 1 Korb cm. 28x29x10h - Einlegesieb und Deckel für Becken - Pommes frites: 10 kg/h (inbegriffen 1 Abschluss-Element mod.TPA-7) • **FR** Friteuse à gaz lt. 13 - Cuve cm. 31,5x34,5x22,5h - 1 Panier cm. 28x29x10h - Filtre, couvercle pour cuve Production de pommes frites: 10 kg/h (inclus 1 Élément de jonction top mod.TPA-7) • **ES** Freidoras a gas 13 lt. - Cuba cm. 31,5x34,5x22,5h - 1 cesta cm. 28x29x10h - Filtro y tapa para cuba Prod. patatas: 10 Kg/h (incluida 1 Chapa de cierre para top mod.TPA-7)  
**cm. 40x 70,5x 28h**



⚡ 12 kW 1.937,00  
10.320 kcal/h 55 / 0,18



# FRIGGITRICI A GAS - TOP

MOD. \_\_\_\_\_  
COD. \_\_\_\_\_

DESCRIZIONE/DESCRIPTION/BEZEICHNUNG/DESCRIPTION/DESCRIPCIÓN  
DIMENSIONI/DIMENSIONS/ABMESSUNGEN/DIMENSIONS/DIMENSIONES

POTENZA/POWER/LEISTUNG/PUISSANCE/POTENCIA  
VOLTAGGIO/VOLTAGE/SPANNUNG/VOLTAGE/VOLTAJE

⚡  $\frac{kW}{kcal/h}$   $\frac{V}{Hz}$

PREZZO/PRICE €  
PREIS/PRIX/PRECIO €  
KG / M<sup>3</sup>

**F2/13T-78G FRIGGITRICE GAS LT. 13+13 2 VASCHE CM. 31,5X34,5X22,5H - 2 CESTI CM. 28X29X10H 2 FILTRI E COPERCHI VASCHE - PROD. PATATE: 20 KG/H (INCLUSA 1 TESTATA CHIUSURA PIANO MOD.TPA-7)**

18260850

**EN** Gas Fryer 13+13 lts - 2 pans cm. 31,5x34,5x22,5h 2 baskets cm. 28x29x10h - 2 sieves and lids for pan Production: 20 kg/h (included 1 Head end filler strip mod.TPA-7) • **DE** Gas-Friteuse lt. 13+13 - 2 Becken cm. 31,5x34,5x22,5h 2 Körbe cm. 28x29x10h - Einlegesieb und Deckel für Becken - Pommes frites: 20 kg/h (inbegriffen 1 Abschluss-Element mod.TPA-7) • **FR** Friteuse à gaz lt. 13+13 - 2 cuves cm. 31,5x34,5x22,5h 2 paniers cm. 28x29x10h - 2 filtres, couvercles pour cuve Production de pommes frites: 20 kg/h (inclus 1 Élément de jonction top mod.TPA-7) • **ES** Freidoras a gas 13+13 lt. - 2 cubas cm. 31,5x34,5x22,5h 2 cestas cm. 28x29x10h - 2 filtros y tapas para cubas. Prod. patatas: 20 Kg/h (incluida 1 Chapa de cierre para top mod.TPA-7)  
**cm. 80x 70,5x 28h**



⚡  $\frac{24 kW}{20.640 kcal/h}$  **3.079,00**  
81 / 0,35

**MFV-78ET BASE CON FORNO ELETTRICO VENTILATO CM. 55X36X34H, TEMP: 50÷300°C, CON 1 GRIGLIA CM.53X32,5 GN1/1 (NON SOVRAPPORRE ELEMENTI AD INDUZIONE)**

08490830

**EN** Stand with electric fan oven cm. 55x36x34h, temp: 50÷300°C, with 1 grid cm.53x32,5 GN1/1 (no induction top) • **DE** unterbau mit Elektro-Heißluftofen cm. 55x36x34h, temp: 50÷300°C, mit 1 Rost cm.53x32,5 GN1/1 (nicht Induktions) • **FR** placard avec Four à chaleur tournante électrique cm. 55x36x34h, temp: 50÷300°C, avec 1 grille cm.53x32,5 GN1/1 (il faut pas de induction) • **ES** mueble con Horno eléctrico ventilado cm. 55x36x34h, temp: 50÷300°C, con 1 parilla cm.53x32,5 GN1/1 (no inducción)  
**cm. 80x 63x 57h**



⚡  $\frac{5,32 kW}{400V\sim 3N}$  **2.885,00**  
 $\frac{230V\sim 3}{50/60 Hz}$  55 / 0,49

**MF-710ET BASE CON FORNO ELETTRICO STATICO CM. 67X55X34H, TEMP: 50÷300°C, CON 1 GRIGLIA CM.65X53 GN2/1 (NON SOVRAPPORRE ELEMENTI AD INDUZIONE)**

08491030

**EN** Stand with traditional electric oven cm. 67x55x34h, temp: 50÷300°C, with 1 grid cm.65x53 GN2/1 (no induction top) • **DE** unterbau mit Statischer Elektro-Backofen cm. 67x55x34h, temp: 50÷300°C, mit 1 Rost cm.65x53 GN2/1 (nicht Induktions) • **FR** placard avec Four électrique statique cm. 67x55x34h, temp: 50÷300°C, avec 1 grille cm.65x53 GN2/1 (il faut pas de induction) • **ES** mueble con Horno eléctrico estático cm. 67x55x34h, temp: 50÷300°C, con 1 parilla cm.65x53 GN2/1 (no inducción)  
**cm. 100x 63x 57h**

⚡  $\frac{5 kW}{400V\sim 3N}$  **2.728,00**  
 $\frac{230V\sim 3}{50/60 Hz}$  60 / 0,73

**CMF-78 COPERCHIO PER MFV-78E**

08490800

**EN** Lid for MFV-78E • **DE** Berichterstattung für MFV-78E • **FR** Couvercle pour MFV-78E • **ES** cubertura para MFV-78E  
**cm. 80x 62,5x 2,8h**

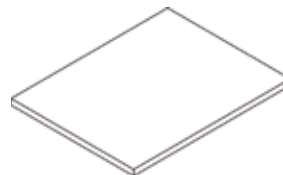

**194,00**  
5 / 0,03

**CMF-710 COPERCHIO PER MF-710E**

08491000

**EN** Lid for MF-710E • **DE** Berichterstattung für MF-710E • **FR** Couvercle pour MF-710E • **ES** cubertura para MF-710E  
**cm. 100x 62,5x 2,8h**

**234,00**  
6 / 0,03



Le immagini presentate non sono vincolanti. La ditta si riserva di apportare modifiche senza preavviso. • The pictures are purely representative. The manufacturer reserves the right to modify the technical data and models without previous notice. • Les images

LO

présentées ne nous engagent pas. La Société se réserve le droit d'apporter tout modification sans préavis. • Die dargestellten Abbildungen sind nicht verbindlich. Technische Änderungen vorbehalten. • Las imágenes presentadas no son vinculantes. El Fabricante se reserva el derecho de modificar sus productos sin previo aviso.

01/20

**219**

70

MOD. \_\_\_\_\_  
COD. \_\_\_\_\_

DESCRIZIONE/DESCRIPTION/BEZEICHNUNG/DESCRIPTION/DESCRIPCIÓN  
DIMENSIONI/DIMENSIONS/ABMESSUNGEN/DIMENSIONS/DIMENSIONES

POTENZA/POWER/LEISTUNG/PUISSANCE/POTENCIA  
VOLTAGGIO/VOLTAGE/SPANNUNG/VOLTAGE/VOLTAJE

⚡ kW kcal/h  
⚡ kw V~ Hz

PREZZO/PRICE €  
PREIS/PRIX/PRECIO €  
KG / M<sup>3</sup>

**MPI-74**  
08410403

**BASE CON PORTA PER INDUZIONE**  
**EN** Stand with door for induction top • **DE** Unterbau für Induktions mit Tür • **FR** Placard pour induction avec porte • **ES** Mueble base para inducción con puerta  
**cm. 40x 62x 57h**



**561,00**  
20 / 0,20

**MPI-78**  
08410803

**cm. 80x 62x 57h**



**634,00**  
27 / 0,37

**M-72**  
08410200

**BASE NEUTRA**  
**EN** Stand • **DE** Unterbau • **FR** Placard • **ES** Mueble base  
**cm. 20x 59,5x 57h**



**341,00**  
12 / 0,12

**M-73**  
08410300

**BASE NEUTRA A GIORNO**  
**EN** Open Stand • **DE** Offener Unterbau • **FR** Placard ouvert • **ES** Mueble base abierto  
**cm. 30x 59,5x 57h**



**346,00**  
14 / 0,16

**M-74**  
08410400

**cm. 40x 59,5x 57h**



**350,00**  
17 / 0,20

**M-76**  
08410600

**cm. 60x 59,5x 57h**



**392,00**  
21 / 0,29

**M-78**  
08410800

**cm. 80x 59,5x 57h**

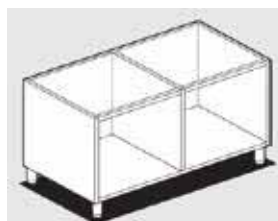

**423,00**  
24 / 0,37

**M-712**  
08411200

**cm. 120x 59,5x 57h**

**596,00**  
35 / 0,54

**M-716**  
08411600

**cm. 160x 59,5x 57h**

**712,00**  
52 / 0,71

MOD. \_\_\_\_\_  
COD. \_\_\_\_\_

DESCRIZIONE/DESCRIPTION/BEZEICHNUNG/DESCRIPTION/DESCRIPCIÓN  
DIMENSIONI/DIMENSIONS/ABMESSUNGEN/DIMENSIONS/DIMENSIONES

POTENZA/POWER/LEISTUNG/PUISSANCE/POTENCIA  
VOLTAGGIO/VOLTAGE/SPANNUNG/VOLTAGE/VOLTAJE

⚡ kW kcal/h  
⚡ kW V~ Hz

PREZZO/PRICE €  
PREIS/PRIX/PRECIO €  
KG / M<sup>3</sup>

**PM-63/73/93-DX PORTA 300 DESTRA**

08430302 **EN** Right door 300 • **DE** Rechte tür 300 • **FR** Porte droite 300 • **ES** Puerta derecha 300  
**cm. 29,5x 2,5x 47,5h**



**157,00**  
3 / 0,01

**PM-64/74/94-DX PORTA 400 DESTRA**

08430402 **EN** Right door 400 • **DE** Rechte tür 400 • **FR** Porte droite 400 • **ES** Puerta derecha 400  
**cm. 39,5x 2,5x 47,5h**



**163,00**  
3.5 / 0,02

**PM-63/73/93-SX PORTA 300 SINISTRA**

08430303 **EN** Left door 300 • **DE** Linke tür 300 • **FR** Porte gauche 300 • **ES** Puerta izquierda 300  
**cm. 29,5x 2,5x 47,5h**

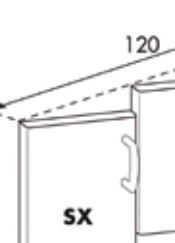

**157,00**  
3 / 0,01

**PM-64/74/94-SX PORTA 400 SINISTRA**

08430403 **EN** Left door 400 • **DE** Linke tür 400 • **FR** Porte gauche 400 • **ES** Puerta izquierda 400  
**cm. 39,5x 2,5x 47,5h**



**163,00**  
3.5 / 0,02

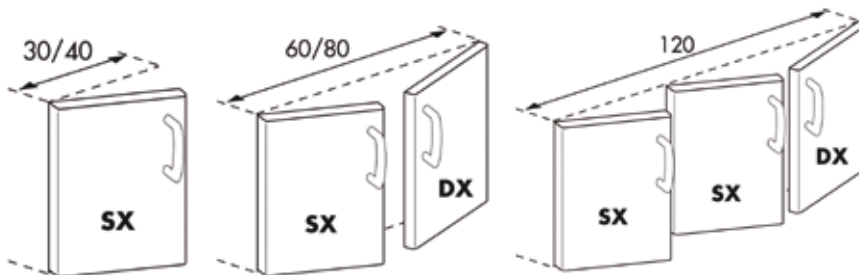

**C-73/93**  
08440320

**CASSETTIERA 300 N. 2 CASSETTI CON 2 BACINELLE INOX, GUIDE TELESCOPICHE. SOLO SU PL**

**EN** Drawer set 300 N. 2 drawers with 2 inox containers, telescopic guides. Only for PL • **DE** Schubladen 300 - N. 2 Schubladen mit 2 Chromnickelstahlbehältern, Telescopeinführungen. Nur für PL • **FR** Tiroirs pour meuble de 300 N. 2 tiroirs avec 2 bacs inox, guides télescopiques. Seulement pour PL • **ES** Cajonera 300 - N. 2 cajones con 2 contenedores de acero inox, guías telescópicas. Solo para PL  
**cm. 29,5x 59x 47,5h**



**611,00**  
16 / 0,19

**C-74/94**  
08440420

**CASSETTIERA 400 - N. 2 CASSETTI CON 2 BACINELLE GN 1/1 15H IN PLASTICA, GUIDE TELESCOPICHE.**

**EN** Drawer set 400 - N. 2 drawers with 2 GN 1/1 15h plastic containers, telescopic guides. • **DE** Schubladen - N. 2 Schubladen mit 2 GN 1/1 15h Kunststoffbehältern, Telescopeinführungen. • **FR** Tiroirs pour meuble de 400 - N. 2 tiroirs avec 2 bacs en plastique GN 1/1 15h, guides télescopiques. • **ES** Cajonera 400 - N. 2 cajones con 2 contenedores GN 1/1 15h de plástico, guías telescópicas.  
**cm. 39,5x 59x 47,5h**



**627,00**  
18 / 0,19



Le immagini presentate non sono vincolanti. La ditta si riserva di apportare modifiche senza preavviso. • The pictures are purely representative. The manufacturer reserves the right to modify the technical data and models without previous notice. • Les images

**LO**

présentées ne nous engagent pas. La Société se réserve le droit d'apporter tout modification sans préavis. • Die dargestellten Abbildungen sind nicht verbindlich. Technische Änderungen vorbehalten. • Las imágenes presentadas no son vinculantes. El Fabricante se reserva el derecho de modificar sus productos sin previo aviso.

01/20

**221**

MOD. \_\_\_\_\_  
COD. \_\_\_\_\_

DESCRIZIONE/DESCRIPTION/BEZEICHNUNG/DESCRIPTION/DESCRIPCIÓN  
DIMENSIONI/DIMENSIONS/ABMESSUNGEN/DIMENSIONS/DIMENSIONES

POTENZA/POWER/LEISTUNG/PUISSANCE/POTENCIA  
VOLTAGGIO/VOLTAGE/SPANNUNG/VOLTAGE/VOLTAJE

⚡ kW kcal/h  
⚡ kW V~ Hz

PREZZO/PRICE €  
PREIS/PRIX/PRECIO €  
KG / M<sup>3</sup>

**C-76/96**  
08440620

**CASSETTIERA 600 N. 2 CASSETTI CON 2 BACINELLE INOX, GUIDE TELESCOPICHE.**

**EN** Drawer set 600 N. 2 drawers with 2 inox containers, telescopic guides. • **DE** Schubladen 600 - N. 2 Schubladen mit 2 Chromnickelstahlbehältern, Teleskopeinführungen. • **FR** Tiroirs pour meuble de 600 N. 2 tiroirs avec 2 bacs inox, guides télescopiques. • **ES** Cajonera 600 - N. 2 cajones con 2 contenedores de acero inox, guías telescópicas.  
**cm. 59,5x 59x 47,5h**



**867,00**  
22 / 0,28

**C-78/98**  
08440820

**CASSETTIERA 800 - N. 2 CASSETTI CON 4 BACINELLE GN 1/1 15H IN PLASTICA, GUIDE TELESCOPICHE.**

**EN** Drawer set 800 - N. 2 drawers with 4 GN 1/1 15h plastic containers, telescopic guides. • **DE** Schubladen 800 - N. 2 Schubladen mit 4 GN 1/1 15h Kunststoffbehältern, Teleskopeinführungen. • **FR** Tiroirs pour meuble de 800 - N. 2 tiroirs avec 4 bacs en plastique GN 1/1 15h, guides télescopiques. • **ES** Cajonera 800 - N. 2 cajones con 4 contenedores GN 1/1 15h de plástico, guías telescópicas.  
**cm. 79,5x 59x 47,5h**



**883,00**  
26 / 0,37

**D-70**  
08470001

**DIVISORIO BASE NEUTRA**

**EN** Spacer for stand • **DE** Trennwand für offener unterbau • **FR** Separation pour placard ouvert • **ES** Divisorio para mueble base  
**cm. 5x 58x 38h**

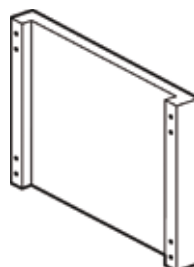

**130,00**  
2.5 / 0,02

**PT-74/94**  
08460002

**PORTATEGLIE VANO 400/600 (GN-1/1) 4 RIPIANI INT. 7 CM.**

**EN** Frame for plates 400/600 (GN-1/1) - N. 4 shelves, wheel-base 7 cm. • **DE** Auflangeschienen für bleche 400/600 (GN-1/1) N. 4 Etagen, Abstand 7 cm. • **FR** Kit porte-plaques 400/600 (GN-1/1) - N. 4 étagères; 7 cm. • **ES** Portacazuelas 400/600 (GN-1/1) - N. 4 estantes, int. 7 cm.

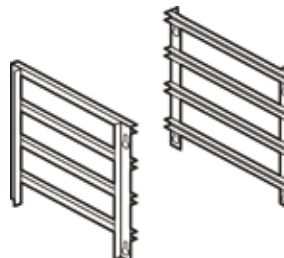

**340,00**  
2.5 / 0,01

**PT-78/98**  
08460012

**PORTATEGLIE VANO 800 (GN-2/1) 4 RIPIANI INT. 7 CM.**

**EN** Frame for plates 800 (GN-2/1) 4 Etagen, Abstand 7 cm. • **DE** Auflangeschienen für bleche 800 (GN-2/1) N. 4 Etagen, Abstand 7 cm. • **FR** Kit porte-plaques 800 (GN-2/1) - N. 4 étagères; 7 cm. • **ES** Portacazuelas 800 (GN-2/1) - N. 4 estantes, int. 7 cm.

**453,00**  
4 / 0,01

**531048800 CESTO 1/2 PER F13T-G/E**

**EN** Basket 1/2 for F13T-G/E • **DE** Korb 1/2 zur Friteuse F13T-G/E • **FR** Panier 1/2 pour F13T-G/E • **ES** Cesta 1/2 para F13T-G/E  
**cm. 13,5x 29x 9h**



**72,00**  
0.8 / 0,03

# ACCESSORI CUOCIPASTA TOP

MOD. \_\_\_\_\_  
COD. \_\_\_\_\_

DESCRIZIONE/DESCRIPTION/BEZEICHNUNG/DESCRIPTION/DESCRIPCIÓN  
DIMENSIONI/DIMENSIONS/ABMESSUNGEN/DIMENSIONS/DIMENSIONES

POTENZA/POWER/LEISTUNG/PUISSANCE/POTENCIA  
VOLTAGGIO/VOLTAGE/SPANNUNG/VOLTAGE/VOLTAJE

⚡ kW kcal/h  
⚡ kw V~ Hz

PREZZO/PRICE €  
PREIS/PRIX/PRECIO €  
KG / M<sup>3</sup>

**531018800 CESTO 1/2 PER CPT-74 - 1/3 PER CPT-76**  
**EN** Basket 1/2 for CPT-74 - 1/3 for CPT-76 • **DE** Korb 1/2 für CPT-74 - 1/3 für CPT-76 • **FR** Panier 1/2 pour CPT-74 - 1/3 pour CPT-76 • **ES** Cesta 1/2 para CPT-74 - 1/3 para CPT-76  
**cm. 14,5x 29x 15h**

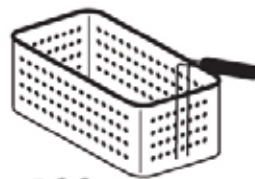

..188..

**103,00**  
1,3 / 0,04

**531053800 CESTO 1/4 PER CPT-76**  
**EN** Basket 1/4 for CPT-76 • **DE** Korb 1/4 für CPT-76  
 • **FR** Panier 1/4 pour CPT-76 • **ES** Cesta 1/4 para CPT-76  
**cm. 11,5x 29x 15h**

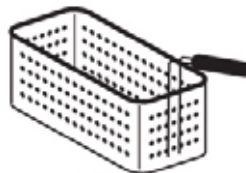

..538..

**97,00**  
1,2 / 0,04

**531040000 CESTO 1/1 PER CPT-76**  
**EN** Basket 1/1 for CPT-76 • **DE** Korb 1/1 für CPT-76  
 • **FR** Panier 1/1 pour CPT-76 • **ES** Cesta 1/1 para CPT-76  
**cm. 49x 29x 15h**



..400..

**176,00**  
3,5 / 0,07

**531053700 CESTO 1/4 PER CPT-74**  
**EN** Basket 1/4 for CPT-74 • **DE** Korb 1/4 für CPT-74  
 • **FR** Panier 1/4 pour CPT-74 • **ES** Cesta 1/4 para CPT-74  
**cm. 14x 16x 15h**

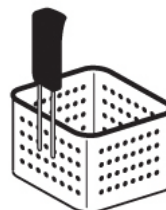

..537..

**69,00**  
1 / 0,02

**531053500 CESTO 1/1 PER CPT-74**  
**EN** Basket 1/1 for CPT-74 • **DE** Korb 1/1 für CPT-74  
 • **FR** Panier 1/1 pour CPT-74 • **ES** Cesta 1/1 para CPT-74  
**cm. 29x 29x 15h**

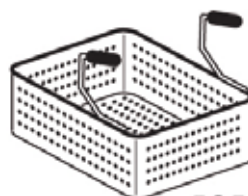

..535..

**127,00**  
1,5 / 0,05

**531071300 CESTO CON GANCIO 1/2 PER CPT-74 - 1/3 PER CPT-76**  
**EN** Basket with hook 1/2 for CPT-74 - 1/3 for CPT-76  
 • **DE** Korb mit Haken 1/2 für CPT-74 - 1/3 für CPT-76  
 • **FR** Panier avec crochet 1/2 pour CPT-74 - 1/3 pour CPT-76 • **ES** Cesta con gancho 1/2 para CPT-74 - 1/3 para CPT-76  
**cm. 13,5x 25,5x 15h**



**102,00**  
1,3 / 0,04

**531071400 CESTO CON GANCIO 1/4 PER CPT-76**  
**EN** Basket with hook 1/4 for CPT-76 • **DE** Korb mit Haken 1/4 für CPT-76 • **FR** Panier avec crochet 1/4 pour CPT-76 • **ES** Cesta con gancho 1/4 para CPT-76  
**cm. 11x 25,5x 15h**

**95,00**  
1,2 / 0,03



Le immagini presentate non sono vincolanti. La ditta si riserva di apportare modifiche senza preavviso. • The pictures are purely representative. The manufacturer reserves the right to modify the technical data and models without previous notice. • Les images

LO

présentées ne nous engagent pas. La Société se réserve le droit d'apporter tout modification sans préavis. • Die dargestellten Abbildungen sind nicht verbindlich. Technische Änderungen vorbehalten. • Las imágenes presentadas no son vinculantes. El Fabricante se reserva el derecho de modificar sus productos sin previo aviso.

01/20

**223**

70



# ACCESSORI CUOCIPASTA TOP

MOD. \_\_\_\_\_  
COD. \_\_\_\_\_

DESCRIZIONE/DESCRIPTION/BEZEICHNUNG/DESCRIPTION/DESCRIPCIÓN  
DIMENSIONI/DIMENSIONS/ABMESSUNGEN/DIMENSIONS/DIMENSIONES

POTENZA/POWER/LEISTUNG/PUISSANCE/POTENCIA  
VOLTAGGIO/VOLTAGE/SPANNUNG/VOLTAGE/VOLTAJE

$\frac{kW}{kcal/h}$   $\frac{kW}{V \sim}$   
Hz

PREZZO/PRICE €  
PREIS/PRIX/PRECIO €  
KG / M<sup>3</sup>

## 531071800 GRIGLIA SUPPORTO CESTI CON GANCIO PER CPT-74

EN support for baskets with hook for CPT-74 • DE Unterstützung für Körbe mit Haken für CPT-74 • FR soutien pour les paniers avec crochet pour CPT-74 • ES soporte para cestas con gancho para CPT-74  
cm. 30x 33x 25h



103,00  
3 / 0,04

## 531071900 GRIGLIA SUPPORTO CESTI CON GANCIO PER CPT-76

EN support for baskets with hook for CPT-76 • DE Unterstützung für Körbe mit Haken für CPT-76 • FR soutien pour les paniers avec crochet pour CPT-76 • ES soporte para cestas con gancho para CPT-76  
cm. 50x 30x 25h



131,00  
3,5 / 0,06



MOD. \_\_\_\_\_  
COD. \_\_\_\_\_

DESCRIZIONE/DESCRIPTION/BEZEICHNUNG/DESCRIPTION/DESCRIPCIÓN  
DIMENSIONI/DIMENSIONS/ABMESSUNGEN/DIMENSIONS/DIMENSIONES

POTENZA/POWER/LEISTUNG/PUISSANCE/POTENCIA  
VOLTAGGIO/VOLTAGE/SPANNUNG/VOLTAGE/VOLTAJE

⚡ kW  
kcal/h  
V~  
Hz

PREZZO/PRICE €  
PREIS/PRIX/PRECIO  
KG / M<sup>3</sup>

**CF4-98ET**  
09660830

**CUCINA 4 PIASTRE - FORNO ELETTRICO STATICO CM. 67X73X34H, TEMP: 50÷300°C, CON 1 GRIGLIA CM.65X71 GN2/1 (INCLUSA 1 TESTATA CHIUSURA PIANO MOD.TPA-9)**

**EN** Electric range - N. 4 plates Traditional electric oven cm. 67x73x34h, temp: 50÷300°C, with 1 grid cm.65x71 GN2/1 (included 1 Head end filler strip mod. TPA-9) • **DE** Elektroherd - N. 4 Kochplatten Statischer Elektro-Backofen cm. 67x73x34h, temp: 50÷300°C, mit 1 Rost cm.65x71 GN2/1 (inbegriffen 1 Abschluss-Element mod.TPA-9) • **FR** Fourneau électrique - N. 4 plaques Four électrique statique cm. 67x73x34h, temp: 50÷300°C, avec 1 grille cm.65x71 GN2/1 (inclus 1 Elément de jonction top mod.TPA-9) • **ES** Cocina eléctrica - N. 4 planchas Horno eléctrico estático cm. 67x73x34h, temp: 50÷300°C, con 1 parilla cm.65x71 GN2/1 (incluida 1 Chapa de cierre para top mod. TPA-9)

**cm. 80x 90x 90h**



⚡ 20,7 kW  
400V~3N  
50/60 Hz

**4.100,00**  
142 / 0,89



**CFV4-98ET**  
09660835

**CUCINA 4 PIASTRE - FORNO ELETTRICO VENTILATO CM. 55X36X34H, TEMP: 50÷300°C, CON 1 GRIGLIA CM.53X32,5 GN1/1 (INCLUSA 1 TESTATA CHIUSURA PIANO MOD.TPA-9)**

**EN** Electric range - N. 4 plates - electric fan oven cm. 55x36x34h, temp: 50÷300°C, with 1 grid cm.53x32,5 GN1/1 (included 1 Head end filler strip mod.TPA-9) • **DE** Elektroherd - N. 4 Kochplatten - Elektro-Heißluftofen cm. 55x36x34h, temp: 50÷300°C, mit 1 Rost cm.53x32,5 GN1/1 (inbegriffen 1 Abschluss-Element mod.TPA-9) • **FR** Fourneau électrique - N. 4 plaques Four à chaleur tournante électrique cm. 55x36x34h, temp: 50÷300°C, avec 1 grille cm.53x32,5 GN1/1 (inclus 1 Elément de jonction top mod.TPA-9) • **ES** Cocina eléctrica - N. 4 planchas - Horno eléctrico ventilado cm. 55x36x34h, temp: 50÷300°C, con 1 parilla cm.53x32,5 GN1/1 (incluida 1 Chapa de cierre para top mod.TPA-9)

**cm. 80x 90x 90h**

⚡ 19,32 kW  
400V~3N  
50/60 Hz

**4.452,00**  
142 / 0,89

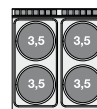

**CFQ4-98ET**  
09660831

**CUCINA 4 PIASTRE QUADRE - FORNO ELETTRICO STATICO CM. 67X73X34H, TEMP: 50÷300°C, CON 1 GRIGLIA CM.65X71 GN2/1 (INCLUSA 1 TESTATA CHIUSURA PIANO MOD. TPA-9)**

**EN** Electric range - N. 4 square plates Traditional electric oven cm. 67x73x34h, temp: 50÷300°C, with 1 grid cm.65x71 GN2/1 (included 1 Head end filler strip mod.TPA-9) • **DE** Elektroherd - N. 4 quadratischen Platten - Statischer Elektro-Backofen cm. 67x73x34h, temp: 50÷300°C, mit 1 Rost cm.65x71 GN2/1 (inbegriffen 1 Abschluss-Element mod.TPA-9) • **FR** Fourneau électrique - N. 4 plaques carrés - Four électrique statique cm. 67x73x34h, temp: 50÷300°C, avec 1 grille cm.65x71 GN2/1 (inclus 1 Elément de jonction top mod.TPA-9) • **ES** Cocina eléctrica - N. 4 planchas cuadradas Horno eléctrico estático cm. 67x73x34h, temp: 50÷300°C, con 1 parilla cm.65x71 GN2/1 (incluida 1 Chapa de cierre para top mod. TPA-9)

**cm. 80x 90x 90h**



⚡ 22,7 kW  
400V~3N  
50/60 Hz

**4.956,00**  
150 / 0,89



MOD. \_\_\_\_\_  
COD. \_\_\_\_\_

DESCRIZIONE/DESCRIPTION/BEZEICHNUNG/DESCRIPTION/DESCRIPCIÓN  
DIMENSIONI/DIMENSIONS/ABMESSUNGEN/DIMENSIONS/DIMENSIONES

POTENZA/POWER/LEISTUNG/PUISSANCE/POTENCIA  
VOLTAGGIO/VOLTAGE/SPANNUNG/VOLTAGE/VOLTAJE

⚡ kW  
kcal/h  
⚡ kw  
V~  
Hz

PREZZO/PRICE €  
PREIS/PRIX/PRECIO €  
KG / M<sup>3</sup>

**CFVQ4-98ET CUCINA 4 PIASTRE QUADRE - FORNO  
ELETTRICO VENTILATO CM. 55X36X34H,  
TEMP: 50÷300°C, CON 1 GRIGLIA  
CM.53X32,5 GN1/1 (INCLUSA 1 TESTATA  
CHIUSURA PIANO MOD.TPA-9)**

09660836

**EN** Electric range - N. 4 square plates - electric fan oven cm. 55x36x34h, temp: 50÷300°C, with 1 grid cm.53x32,5 GN1/1 (included 1 Head end filler strip mod.TPA-9) • **DE** Elektroherd - N. 4 quadratischen Platten - Elektro-Heißluftofen cm. 55x36x34h, temp: 50÷300°C, mit 1 Rost cm.53x32,5 GN1/1 (inbegriffen 1 Abschluss-Element mod.TPA-9) • **FR** Fourneau électrique - N. 4 plaques carrées - Four à chaleur tournante électrique cm. 55x36x34h, temp: 50÷300°C, avec 1 grille cm.53x32,5 GN1/1 (inclus 1 Élément de jonction top mod.TPA-9) • **ES** Cocina eléctrica - N. 4 planchas cuadradas Horno eléctrico ventilado cm. 55x36x34h, temp: 50÷300°C, con 1 parilla cm.53x32,5 GN1/1 (incluida 1 Chapa de cierre para top mod.TPA-9)  
**cm. 80x 90x 90h**



⚡ 21,32 kW  
400V~3N  
50/60 Hz

**5.308,00**  
150 / 0,89



**CFC4-98ET CUCINA 4 PIASTRE VETROCERAMICA CM.  
75 X 75 - FORNO ELETTRICO STATICO CM.  
67X73X34H, TEMP: 50÷300°C, CON 1  
GRIGLIA CM.65X71 GN2/1 (INCLUSA 1  
TESTATA CHIUSURA PIANO MOD.TPA-9)**

09660832

**EN** Electric range N. 4 plates ceramic glass cm. 75 x 75 - traditional electric oven cm. 67x73x34h, temp: 50÷300°C, with 1 grid cm.65x71 GN2/1 (included 1 Head end filler strip mod.TPA-9) • **DE** Elektroherd N. 4 Ceran-Kochplatten cm. 75 x 75 - Statischer Elektro-Backofen cm. 67x73x34h, temp: 50÷300°C, mit 1 Rost cm.65x71 GN2/1 (inbegriffen 1 Abschluss-Element mod.TPA-9) • **FR** Fourneau électrique N. 4 plaques vitroceramique cm. 75 x 75 - Four électrique statique cm. 67x73x34h, temp: 50÷300°C, avec 1 grille cm.65x71 GN2/1 (inclus 1 Élément de jonction top mod.TPA-9) • **ES** Cocina eléctrica N. 4 planchas vitrocerámica cm. 75 x 75 - Horno eléctrico estático cm. 67x73x34h, temp: 50÷300°C, con 1 parilla cm.65x71 GN2/1 (incluida 1 Chapa de cierre para top mod.TPA-9)  
**cm. 80x 90x 90h**



⚡ 20,3 kW  
400V~3N  
50/60 Hz

**5.479,00**  
130 / 0,89

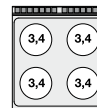

**CFVC4-98ET CUCINA 4 PIASTRE VETROCERAMICA CM.  
75 X 75 - FORNO ELETTRICO VENTILATO  
CM. 55X36X34H, TEMP: 50÷300°C, CON 1  
GRIGLIA CM.53X32,5 GN1/1 (INCLUSA 1  
TESTATA CHIUSURA PIANO MOD.TPA-9)**

09660837

**EN** Electric range N. 4 plates ceramic glass cm. 75 x 75 - electric fan oven cm. 55x36x34h, temp: 50÷300°C, with 1 grid cm.53x32,5 GN1/1 (included 1 Head end filler strip mod.TPA-9) • **DE** Elektroherd N. 4 Ceran-Kochplatten cm. 75 x 75 - Elektro-Heißluftofen cm. 55x36x34h, temp: 50÷300°C, mit 1 Rost cm.53x32,5 GN1/1 (inbegriffen 1 Abschluss-Element mod.TPA-9) • **FR** Fourneau électrique N. 4 plaques vitroceramique cm. 75 x 75 - Four à chaleur tournante électrique cm. 55x36x34h, temp: 50÷300°C, avec 1 grille cm.53x32,5 GN1/1 (inclus 1 Élément de jonction top mod.TPA-9) • **ES** Cocina eléctrica N. 4 planchas vitrocerámica cm. 75 x 75 - Horno eléctrico ventilado cm. 55x36x34h, temp: 50÷300°C, con 1 parilla cm.53x32,5 GN1/1 (incluida 1 Chapa de cierre para top mod.TPA-9)  
**cm. 80x 90x 90h**

⚡ 18,92 kW  
400V~3N  
50/60 Hz

**5.830,00**  
130 / 0,89



MOD. \_\_\_\_\_  
COD.

DESCRIZIONE/DESCRIPTION/BEZEICHNUNG/DESCRIPTION/DESCRIPCIÓN  
DIMENSIONI/DIMENSIONS/ABMESSUNGEN/DIMENSIONS/DIMENSIONES

POTENZA/POWER/LEISTUNG/PUISSANCE/POTENCIA  
VOLTAGGIO/VOLTAGE/SPANNUNG/VOLTAGE/VOLTAJE

⚡ kW kcal/h  
⚡ kW V~ Hz

PREZZO/PRICE €  
PREIS/PRIX/PRECIO €  
KG / M<sup>3</sup>

**CF4-98G**  
09680850

**CUCINA 4 FUOCHI - FORNO A GAS STATICO**  
**CM. 67X73X34H, TEMP: 150÷300°C, CON**  
**1 GRIGLIA CM.65X71 GN2/1 (INCLUSA 1**  
**TESTATA CHIUSURA PIANO MOD.TPC-9)**

**EN** Gas Range - N. 4 burners Traditional gas-oven cm. 67x73x34h, temp: 150÷300°C, with 1 grid cm.65x71 GN2/1 (included 1 Head end filler strip mod.TPC-9)  
• **DE** Gasherd - N. 4 Kochstellen Statischer Gas-Backofen cm. 67x73x34h, temp: 150÷300°C, mit 1 Rost cm.65x71 GN2/1 (inbegriffen 1 Abschluss-Element mod.TPC-9)  
• **FR** Cuisiniere gaz - N. 4 feux vifs Four à gaz statique cm. 67x73x34h, temp: 150÷300°C, avec 1 grille cm.65x71 GN2/1 (inclus 1 Élément de jonction top mod.TPC-9)  
• **ES** Cocina a gas - N. 4 quemadores Horno a gas estático cm. 67x73x34h, temp: 150÷300°C, con 1 parilla cm.65x71 GN2/1 (incluida 1 Chapa de cierre para top mod.TPC-9)  
**cm. 80x 90x 90h**



⚡ 36,5 kW  
31.390 kcal/h

**3.829,00**  
166 / 0,89

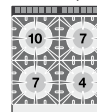

**CF4-98GE**  
09690860

**CUCINA 4 FUOCHI - FORNO ELETTRICO**  
**STATICO CM. 67X73X34H, TEMP: 50÷300°C,**  
**CON 1 GRIGLIA CM.65X71 GN2/1 (INCLUSA**  
**1 TESTATA CHIUSURA PIANO MOD.TPC-9)**

**EN** Gas Range - N. 4 burners - traditional electric oven cm. 67x73x34h, temp: 50÷300°C, with 1 grid cm.65x71 GN2/1 (included 1 Head end filler strip mod.TPC-9)  
• **DE** Gasherd - N. 4 Kochstellen Statischer Elektro-Backofen cm. 67x73x34h, temp: 50÷300°C, mit 1 Rost cm.65x71 GN2/1 (inbegriffen 1 Abschluss-Element mod.TPC-9)  
• **FR** Cuisiniere gaz - N. 4 feux vifs Four électrique statique cm. 67x73x34h, temp: 50÷300°C, avec 1 grille cm.65x71 GN2/1 (inclus 1 Élément de jonction top mod.TPC-9)  
• **ES** Cocina a gas - N. 4 quemadores Horno eléctrico estático cm. 67x73x34h, temp: 50÷300°C, con 1 parilla cm.65x71 GN2/1 (incluida 1 Chapa de cierre para top mod.TPC-9)  
**cm. 80x 90x 90h**



⚡ 28 kW  
24.080 kcal/h

**3.905,00**  
164 / 0,89

⚡ 6,7 kW  
400V~3N  
50/60 Hz

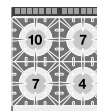

**CFV4-98GE**  
09690865

**CUCINA 4 FUOCHI - FORNO ELETTRICO**  
**VENTILATO CM. 55X36X34H, TEMP:**  
**50÷300°C, CON 1 GRIGLIA CM.53X32,5**  
**GN1/1 (INCLUSA 1 TESTATA CHIUSURA**  
**PIANO MOD.TPC-9)**

**EN** Gas Range - N. 4 burners - electric fan oven cm. 55x36x34h, temp: 50÷300°C, with 1 grid cm.53x32,5 GN1/1 (included 1 Head end filler strip mod.TPC-9)  
• **DE** Gasherd - N. 4 Kochstellen Elektro-Heißluftofen cm. 55x36x34h, temp: 50÷300°C, mit 1 Rost cm.53x32,5 GN1/1 (inbegriffen 1 Abschluss-Element mod.TPC-9)  
• **FR** Cuisiniere gaz - N. 4 feux vifs Four à chaleur tournante électrique cm. 55x36x34h, temp: 50÷300°C, avec 1 grille cm.53x32,5 GN1/1 (inclus 1 Élément de jonction top mod.TPC-9)  
• **ES** Cocina a gas - N. 4 quemadores Horno eléctrico ventilado cm. 55x36x34h, temp: 50÷300°C, con 1 parilla cm.53x32,5 GN1/1 (incluida 1 Chapa de cierre para top mod.TPC-9)  
**cm. 80x 90x 90h**

⚡ 28 kW  
24.080 kcal/h

**4.255,00**  
164 / 0,89

⚡ 5,32 kW  
400V~3N  
230V~3  
50/60 Hz

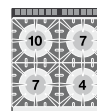



MOD. \_\_\_\_\_  
COD. \_\_\_\_\_

DESCRIZIONE / DESCRIPTION / BEZEICHNUNG / DESCRIPTION / DESCRIPCIÓN  
DIMENSIONI / DIMENSIONS / ABMESSUNGEN / DIMENSIONS / DIMENSIONES

POTENZA / POWER / LEISTUNG / PUISSANCE / POTENCIA  
VOLTAGGIO / VOLTAGE / SPANNUNG / VOLTAGE / VOLTAJE

⚡ kW kcal/h  
⚡ kW kcal/h  
V~ Hz

PREZZO / PRICE €  
PREIS / PRIX / PRECIO €  
KG / M<sup>3</sup>

**CFA4-98G**  
09750850

**CUCINA ACQUA 4 FUOCHI - FORNO A GAS STATICO CM. 67X73X34H, TEMP: 150÷300°C, CON 1 GRIGLIA CM.65X71 GN2/1 - RUBINETTO CARICO ACQUA, SFIORATORE (INCLUSA 1 TESTATA CHIUSURA PIANO MOD. TPA-9)**

**EN** Water range - N. 4 burners Traditional gas-oven cm. 67x73x34h, temp: 150÷300°C, with 1 grid cm.65x71 GN2/1 - Water loading tap + overflow device (included 1 Head end filler strip mod.TPA-9) • **DE** Wasser herd - N. 4 Kochstellen Statischer Gas-Backofen cm. 67x73x34h, temp: 150÷300°C, mit 1 Rost cm.65x71 GN2/1 - Wasserlauf-Hahn + Überlauf-Vorrichtung (inbegriffen 1 Abschluss-Element mod.TPA-9) • **FR** Cuisinière l'eau - N. 4 feux vifs Four à gaz statique cm. 67x73x34h, temp: 150÷300°C, avec 1 grille cm.65x71 GN2/1 - Robinet d'arrivée d'eau trop plein (inclus 1 Élément de jonction top mod.TPA-9) • **ES** Cocina a agua - N. 4 quemadores Horno a gas estático cm. 67x73x34h, temp: 150÷300°C, con 1 parilla cm.65x71 GN2/1 - Grifo carga agua + vertedero (incluida 1 Chapa de cierre para top mod.TPA-9)  
**cm. 80x 90x 90h**



⚡ 36,5 kW  
31.390 kcal/h

**5.123,00**  
166 / 0,89



**CF6-912ETV**  
09661230

**CUCINA 6 PIASTRE - FORNO ELETTRICO STATICO CM. 67X73X34H, TEMP: 50÷300°C, CON 1 GRIGLIA CM.65X71 GN2/1 - VANO NEUTRO CON PORTA (INCLUSA 1 TESTATA CHIUSURA PIANO MOD.TPA-9)**

**EN** Electric range - N. 6 plates Traditional electric oven cm. 67x73x34h, temp: 50÷300°C, with 1 grid cm.65x71 GN2/1 - Neutral cabinet with door (included 1 Head end filler strip mod.TPA-9) • **DE** Elektroherd - N. 6 Kochplatten Statischer Elektro-Backofen cm. 67x73x34h, temp: 50÷300°C, mit 1 Rost cm.65x71 GN2/1 - Neutrales Schrankelement mit Tür (inbegriffen 1 Abschluss-Element mod.TPA-9) • **FR** Fourneau électrique - N. 6 plaques Four électrique statique cm. 67x73x34h, temp: 50÷300°C, avec 1 grille cm.65x71 GN2/1 - Element neutre avec porte (inclus 1 Élément de jonction top mod.TPA-9) • **ES** Cocina eléctrica - N. 6 planchas Horno eléctrico estático cm. 67x73x34h, temp: 50÷300°C, con 1 parilla cm.65x71 GN2/1 - Armario neutro con puerta (incluida 1 Chapa de cierre para top mod.TPA-9)  
**cm. 120x 90x 90h**



⚡ 27,7 kW  
400V~3N  
50/60 Hz

**5.400,00**  
200 / 1,32

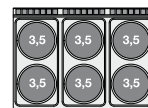

**CFV6-912ETV**  
09661235

**CUCINA 6 PIASTRE - FORNO ELETTRICO VENTILATO CM. 55X36X34H, TEMP: 50÷300°C, CON 1 GRIGLIA CM.53X32,5 GN1/1 - VANO NEUTRO CON PORTA (INCLUSA 1 TESTATA CHIUSURA PIANO MOD. TPA-9)**

**EN** Electric range - N. 6 plates electric fan oven cm. 55x36x34h, temp: 50÷300°C, with 1 grid cm.53x32,5 GN1/1 - Neutral cabinet with door (included 1 Head end filler strip mod.TPA-9) • **DE** Elektroherd - N. 6 Kochplatten Elektro-Heißluftofen cm. 55x36x34h, temp: 50÷300°C, mit 1 Rost cm.53x32,5 GN1/1 - Neutrales Schrankelement mit Tür (inbegriffen 1 Abschluss-Element mod.TPA-9) • **FR** Fourneau électrique - N. 6 plaques Four à chaleur tournante électrique cm. 55x36x34h, temp: 50÷300°C, avec 1 grille cm.53x32,5 GN1/1 - Element neutre avec porte (inclus 1 Élément de jonction top mod.TPA-9) • **ES** Cocina eléctrica - N. 6 planchas Horno eléctrico ventilado cm. 55x36x34h, temp: 50÷300°C, con 1 parilla cm.53x32,5 GN1/1 - Armario neutro con puerta (incluida 1 Chapa de cierre para top mod.TPA-9)  
**cm. 120x 90x 90h**

⚡ 26,32 kW  
400V~3N  
50/60 Hz

**5.751,00**  
200 / 1,32

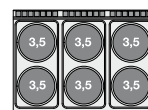

MOD. \_\_\_\_\_  
COD. \_\_\_\_\_

DESCRIZIONE/DESCRIPTION/BEZEICHNUNG/DESCRIPTION/DESCRIPCIÓN  
DIMENSIONI/DIMENSIONS/ABMESSUNGEN/DIMENSIONS/DIMENSIONES

POTENZA/POWER/LEISTUNG/PUISSANCE/POTENCIA  
VOLTAGGIO/VOLTAGE/SPANNUNG/VOLTAGE/VOLTAJE

⚡ kW \_\_\_\_\_  
kcal/h \_\_\_\_\_  
V~ \_\_\_\_\_  
Hz \_\_\_\_\_

PREZZO/PRICE € \_\_\_\_\_  
PREIS/PRIX/PRECIO € \_\_\_\_\_  
KG / M<sup>3</sup> \_\_\_\_\_

**CFQ6-912ETV CUCINA 6 PIASTRE QUADRE - FORNO ELETTRICO STATICO CM. 67X73X34H, TEMP: 50÷300°C, CON 1 GRIGLIA CM.65X71 GN2/1 - VANO NEUTRO CON PORTA (INCLUSA 1 TESTATA CHIUSURA PIANO MOD.TPA-9)**  
**EN** Electric range - N. 6 square plates Traditional electric oven cm. 67x73x34h, temp: 50÷300°C, with 1 grid cm.65x71 GN2/1 - Neutral cabinet with door (included 1 Head end filler strip mod.TPA-9) • **DE** Elektroherd - N. 6 quadratischen Platten Statischer Elektro-Backofen cm. 67x73x34h, temp: 50÷300°C, mit 1 Rost cm.65x71 GN2/1 - Neutrales Schrankelement mit Tür (inbegriffen 1 Abschluss-Element mod.TPA-9) • **FR** Fourneau électrique - N. 6 plaques carrés Four électrique statique cm. 67x73x34h, temp: 50÷300°C, avec 1 grille cm.65x71 GN2/1 - Element neutre avec porte (inclus 1 Élément de jonction top mod.TPA-9) • **ES** Cocina eléctrica - N. 6 planchas cuadradas Horno eléctrico estático cm. 67x73x34h, temp: 50÷300°C, con 1 parilla cm.65x71 GN2/1 - Armario neutro con puerta (incluida 1 Chapa de cierre para top mod.TPA-9)  
**cm. 120x 90x 90h**



⚡ 30,7 kW \_\_\_\_\_ **6.828,00**  
400V~3N \_\_\_\_\_ 212 / 1,32  
50/60 Hz



**CFVQ6-912ETV CUCINA 6 PIASTRE QUADRE - FORNO ELETTRICO VENTILATO CM. 55X36X34H, TEMP: 50÷300°C, CON 1 GRIGLIA CM.53X32,5 GN1/1 - VANO NEUTRO CON PORTA (INCLUSA 1 TESTATA CHIUSURA PIANO MOD.TPA-9)**  
**EN** Electric range - N. 6 square plates electric fan oven cm. 55x36x34h, temp: 50÷300°C, with 1 grid cm.53x32,5 GN1/1 - Neutral cabinet with door (included 1 Head end filler strip mod.TPA-9) • **DE** Elektroherd - N. 6 quadratischen Platten Elektro-Heißluftofen cm. 55x36x34h, temp: 50÷300°C, mit 1 Rost cm.53x32,5 GN1/1 - Neutrales Schrankelement mit Tür (inbegriffen 1 Abschluss-Element mod.TPA-9) • **FR** Fourneau électrique - N. 6 plaques carrés Four à chaleur tournante électrique cm. 55x36x34h, temp: 50÷300°C, avec 1 grille cm.53x32,5 GN1/1 - Element neutre avec porte (inclus 1 Élément de jonction top mod.TPA-9) • **ES** Cocina eléctrica - N. 6 planchas cuadradas Horno eléctrico ventilado cm. 55x36x34h, temp: 50÷300°C, con 1 parilla cm.53x32,5 GN1/1 - Armario neutro con puerta (incluida 1 Chapa de cierre para top mod.TPA-9)  
**cm. 120x 90x 90h**

⚡ 29,32 kW \_\_\_\_\_ **7.179,00**  
400V~3N \_\_\_\_\_ 212 / 1,32  
50/60 Hz

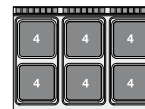

**CF6-912ET CUCINA 6 PIASTRE FORNO ELETTRICO STATICO CM. 107X73X34H, TEMP: 50÷300°C, CON 1 GRIGLIA CM.105X71 (INCLUSA 1 TESTATA CHIUSURA PIANO MOD.TPA-9)**  
**EN** Electric Range - N. 6 plates Traditional electric oven cm. 107x73x34h, temp: 50÷300°C, with 1 grid cm.105x71 (included 1 Head end filler strip mod.TPA-9) • **DE** Elektroherd - N. 6 Kochplatten Statischer Elektro-Backofen cm. 107x73x34h, temp: 50÷300°C, mit 1 Rost cm.105x71 (inbegriffen 1 Abschluss-Element mod.TPA-9) • **FR** Fourneau électrique - N. 6 plaques Four électrique statique cm. 107x73x34h, temp: 50÷300°C, avec 1 grille cm.105x71 (inclus 1 Élément de jonction top mod.TPA-9) • **ES** Cocina eléctrica - N. 6 planchas Horno eléctrico estático cm. 107x73x34h, temp: 50÷300°C, con 1 parilla cm.105x71 (incluida 1 Chapa de cierre para top mod.TPA-9)  
**cm. 120x 90x 90h**



⚡ 30,2 kW \_\_\_\_\_ **5.851,00**  
400V~3N \_\_\_\_\_ 206 / 1,32  
50/60 Hz

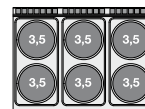

MOD. \_\_\_\_\_  
COD. \_\_\_\_\_

DESCRIZIONE/DESCRIPTION/BEZEICHNUNG/DESCRIPTION/DESCRIPCIÓN  
DIMENSIONI/DIMENSIONS/ABMESSUNGEN/DIMENSIONS/DIMENSIONES

POTENZA/POWER/LEISTUNG/PUISSANCE/POTENCIA  
VOLTAGGIO/VOLTAGE/SPANNUNG/VOLTAGE/VOLTAJE

⚡ kW  
kcal/h

⚡ kW  
V~  
Hz

PREZZO/PRICE €  
PREIS/PRIX/PRECIO €  
KG / M<sup>3</sup>

**CFQ6-912ET CUCINA 6 PIASTRE QUADRE FORNO  
ELETTRICO STATICO CM. 107X73X34H, TEMP:  
50÷300°C, CON 1 GRIGLIA CM.105X71  
(INCLUSA 1 TESTATA CHIUSURA PIANO MOD.  
TPA-9)**

09661233

**EN** Electric Range - N. 6 square plates Traditional electric oven cm. 107x73x34h, temp: 50÷300°C, with 1 grid cm.105x71 (included 1 Head end filler strip mod.TPA-9) • **DE** Elektroherd - N. 6 quadratischen Platten Statischer Elektro-Backofen cm. 107x73x34h, temp: 50÷300°C, mit 1 Rost cm.105x71 (inbegriffen 1 Abschluss-Element mod.TPA-9) • **FR** Fourneau électrique - N. 6 plaques carrés Four électrique statique cm. 107x73x34h, temp: 50÷300°C, avec 1 grille cm.105x71 (inclus 1 Élément de jonction top mod.TPA-9) • **ES** Cocina eléctrica - N. 6 planchas cuadradas Horno eléctrico estático cm. 107x73x34h, temp: 50÷300°C, con 1 parilla cm.105x71 (incluida 1 Chapa de cierre para top mod.TPA-9)  
**cm. 120x 90x 90h**



⚡ 33,2 kW **7.273,00**  
400V~3N 218 / 1,32  
50/60 Hz



**CF6-912GV CUCINA 6 FUOCHI FORNO A GAS STATICO  
CM. 67X73X34H, TEMP: 150÷300°C, CON 1  
GRIGLIA CM.65X71 GN2/1 - VANO NEUTRO  
CON PORTA (INCLUSA 1 TESTATA CHIUSURA  
PIANO MOD.TPC-9)**

09681251

**EN** Gas Range - N. 6 burners Traditional gas-oven GN cm. 67x73x34h, temp: 150÷300°C, with 1 grid cm.65x71 GN2/1 - Neutral cabinet with door (included 1 Head end filler strip mod.TPC-9) • **DE** Gasherd - N. 6 Kochstellen - Statischer Gas-Backofen cm. 67x73x34h, temp: 150÷300°C, mit 1 Rost cm.65x71 GN2/1 - Neutrales Schrankelement mit Tür (inbegriffen 1 Abschluss-Element mod.TPC-9) • **FR** Cuisiniere Gaz - N. 6 feux vifs Four à gaz statique cm. 67x73x34h, temp: 150÷300°C, avec 1 grille cm.65x71 GN2/1 - Élément neutre avec porte (inclus 1 Élément de jonction top mod.TPC-9) • **ES** Cocina a gas - N. 6 quemadores Horno a gas estático cm. 67x73x34h, temp: 150÷300°C, con 1 parilla cm.65x71 GN2/1 - Armario neutro con puerta (incluida 1 Chapa de cierre para top mod.TPC-9)  
**cm. 120x 90x 90h**



⚡ 53,5 kW **5.188,00**  
46.010 kcal/h 230 / 1,32

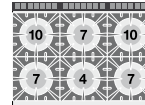

**CF6-912GEV CUCINA 6 FUOCHI - FORNO ELETTRICO  
STATICO CM. 67X73X34H, TEMP: 50÷300°C,  
CON 1 GRIGLIA CM.65X71 GN2/1 - VANO  
NEUTRO CON PORTA (INCLUSA 1 TESTATA  
CHIUSURA PIANO MOD.TPC-9)**

09691261

**EN** Gas Range - N. 6 burners - traditional electric oven cm. 67x73x34h, temp: 50÷300°C, with 1 grid cm.65x71 GN2/1 - Neutral cabinet with door (included 1 Head end filler strip mod.TPC-9) • **DE** Gasherd - N. 6 Kochstellen Statischer Elektro-Backofen cm. 67x73x34h, temp: 50÷300°C, mit 1 Rost cm.65x71 GN2/1 - Neutrales Schrankelement mit Tür (inbegriffen 1 Abschluss-Element mod.TPC-9) • **FR** Cuisiniere gaz - N. 6 feux vifs Four électrique statique cm. 67x73x34h, temp: 50÷300°C, avec 1 grille cm.65x71 GN2/1 - Élément neutre avec porte (inclus 1 Élément de jonction top mod.TPC-9) • **ES** Cocina a gas - N. 6 quemadores Horno eléctrico estático cm. 67x73x34h, temp: 50÷300°C, con 1 parilla cm.65x71 GN2/1 - Armario neutro con puerta (incluida 1 Chapa de cierre para top mod.TPC-9)  
**cm. 120x 90x 90h**



⚡ 45 kW **5.281,00**  
38.700 kcal/h 228 / 1,32

⚡ 6,7 kW  
400V~3N  
50/60 Hz

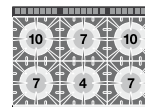

# CUCINE A GAS CON FORNO ELETTRICO

MOD. \_\_\_\_\_  
COD. \_\_\_\_\_

DESCRIZIONE / DESCRIPTION / BEZEICHNUNG / DESCRIPTION / DESCRIPCIÓN  
DIMENSIONI / DIMENSIONS / ABMESSUNGEN / DIMENSIONS / DIMENSIONES

POTENZA / POWER / LEISTUNG / PUISSANCE / POTENCIA  
VOLTAGGIO / VOLTAGE / SPANNUNG / VOLTAGE / VOLTAJE

⚡ kW  
kcal/h  
⚡ kW  
V~  
Hz

PREZZO / PRICE €  
PREIS / PRIX / PRECIO €  
KG / M<sup>3</sup>

**CFV6-912GEV CUCINA 6 FUOCHI - FORNO ELETTRICO VENTILATO CM. 55X36X34H, TEMP: 50÷300°C, CON 1 GRIGLIA CM.53X32,5 GN1/1 - VANO NEUTRO CON PORTA (INCLUSA 1 TESTATA CHIUSURA PIANO MOD. TPC-9)**

09691266

**EN** Gas Range - N. 6 burners - electric fan oven cm. 55x36x34h, temp: 50÷300°C, with 1 grid cm.53x32,5 GN1/1 - Neutral cabinet with door (included 1 Head end filler strip mod.TPC-9) • **DE** Gas Range - N. 6 burners - electric fan oven cm. 55x36x34h, temp: 50÷300°C, mit 1 Rost cm.53x32,5 GN1/1 - Neutral cabinet with door (inbegriffen 1 Abschluss-Element mod. TPC-9) • **FR** Gas Range - N. 6 burners - electric fan oven cm. 55x36x34h, temp: 50÷300°C, avec 1 grille cm.53x32,5 GN1/1 - Neutral cabinet with door (inclus 1 Élément de jonction top mod.TPC-9) • **ES** Gas Range - N. 6 burners - electric fan oven cm. 55x36x34h, temp: 50÷300°C, con 1 parilla cm.53x32,5 GN1/1 - Neutral cabinet with door (incluida 1 Chapa de cierre para top mod.TPC-9)  
**cm. 120x 90x 90h**



⚡ 45 kW  
38.700 kcal/h **5.636,00**  
228 / 1,32

⚡ 5,32 kW  
400V~3N  
230V~3  
50/60 Hz

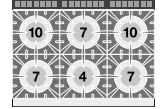

**CFA6-912GV CUCINA ACQUA 6 FUOCHI - FORNO A GAS STATICO CM. 67X73X34H, TEMP: 150÷300°C, CON 1 GRIGLIA CM.65X71 GN2/1 - VANO NEUTRO CON PORTA - RUBINETTO CARICO ACQUA, SFIORATORE (INCLUSA 1 TESTATA CHIUSURA PIANO MOD.TPA-9)**

09751251

**EN** Water range - N. 6 burners - Traditional gas-oven cm. 67x73x34h, temp: 150÷300°C, with 1 grid cm.65x71 GN2/1 - Neutral cabinet with door - Water loading tap + overflow device (included 1 Head end filler strip mod.TPA-9) • **DE** Wasser herd - N. 6 Kochstellen - Statischer Gas-Backofen cm. 67x73x34h, temp: 150÷300°C, mit 1 Rost cm.65x71 GN2/1 - Neutrales Schrankelement mit Tür - Wasserlauf-Hahn + Überlauf-Vorrichtung (inbegriffen 1 Abschluss-Element mod.TPA-9) • **FR** Cuisiniere l'eau - N. 6 feux vifs Four à gaz statique cm. 67x73x34h, temp: 150÷300°C, avec 1 grille cm.65x71 GN2/1 - Element neutre avec porte - Robinet d'arrivée d'eau trop plein (inclus 1 Élément de jonction top mod.TPA-9) • **ES** Cocina a agua N. 6 quemadores Horno a gas estático cm. 67x73x34h, temp: 150÷300°C, con 1 parilla cm.65x71 GN2/1 - Armario neutro con puerta - Grifo carga agua + vertedero (incluida 1 Chapa de cierre para top mod. TPA-9)  
**cm. 120x 90x 90h**



⚡ 50,5 kW  
43.430 kcal/h **6.686,00**  
230 / 1,32



**CF6-912G CUCINA 6 FUOCHI FORNO A GAS STATICO CM. 107X73X34H, TEMP: 150÷300°C, CON 1 GRIGLIA CM.105X71 (INCLUSA 1 TESTATA CHIUSURA PIANO MOD.TPC-9)**

09681250

**EN** Gas Range - N. 6 burners Traditional gas-oven cm. 107x73x34h, temp: 150÷300°C, with 1 grid cm.105x71 (included 1 Head end filler strip mod. TPC-9) • **DE** Gasher - N. 6 Kochstellen Statischer Gas-Backofen cm. 107x73x34h, temp: 150÷300°C, mit 1 Rost cm.105x71 (inbegriffen 1 Abschluss-Element mod. TPC-9) • **FR** Cuisiniere gaz - N. 6 feux vifs Four à gaz statique cm. 107x73x34h, temp: 150÷300°C, avec 1 grille cm.105x71 (inclus 1 Élément de jonction top mod. TPC-9) • **ES** Cocina a gas - N. 6 quemadores Horno a gas estático cm. 107x73x34h, temp: 150÷300°C, con 1 parilla cm.105x71 (incluida 1 Chapa de cierre para top mod.TPC-9)  
**cm. 120x 90x 90h**



⚡ 58 kW  
49.820 kcal/h **5.579,00**  
236 / 1,32

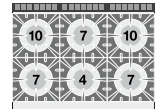



# CUCINE A GAS CON FORNO ELETTRICO

MOD. \_\_\_\_\_  
COD. \_\_\_\_\_

DESCRIZIONE/DESCRIPTION/BEZEICHNUNG/DESCRIPTION/DESCRIPCIÓN  
DIMENSIONI/DIMENSIONS/ABMESSUNGEN/DIMENSIONS/DIMENSIONES

POTENZA/POWER/LEISTUNG/PUISSANCE/POTENCIA  
VOLTAGGIO/VOLTAGE/SPANNUNG/VOLTAGE/VOLTAJE

⚡ kW kcal/h  
⚡ kw V~ Hz

PREZZO/PRICE €  
PREIS/PRIX/PRECIO €  
KG / M<sup>3</sup>

**CF6-912GE**  
09691260

**CUCINA 6 FUOCHI FORNO ELETTRICO STATICO**  
**CM. 107X73X34H, TEMP: 50÷300°C, CON**  
**1 GRIGLIA CM.105X71 (INCLUSA 1 TESTATA**  
**CHIUSURA PIANO MOD.TPC-9)**

**EN** Gas Range - N. 6 burners Traditional electric oven cm. 107x73x34h, temp: 50÷300°C, with 1 grid cm.105x71 (included 1 Head end filler strip mod.TPC-9)  
• **DE** Gasherd - N. 6 Kochstellen Statischer Elektro-Backofen cm. 107x73x34h, temp: 50÷300°C, mit 1 Rost cm.105x71 (inbegriffen 1 Abschluss-Element mod.TPC-9)  
• **FR** Cuisiniere gaz - N. 6 feux vifs Four électrique statique cm. 107x73x34h, temp: 50÷300°C, avec 1 grille cm.105x71 (inclus 1 Élément de jonction top mod.TPC-9)  
• **ES** Cocina a gas - N. 6 quemadores Horno eléctrico estático cm. 107x73x34h, temp: 50÷300°C, con 1 parilla cm.105x71 (incluida 1 Chapa de cierre para top mod.TPC-9)  
**cm. 120x 90x 90h**



⚡ 45 kW kcal/h **5.683,00**  
38.700 kcal/h 230 / 1,32

⚡ 9,2 kW  
400V~3N  
50/60 Hz

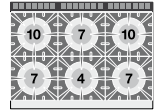

**CF8-916ET**  
09661632

**CUCINA 8 PIASTRE - 2 FORNI ELETTRICI**  
**STATICI CM. 67X73X34H, TEMP: 50÷300°C,**  
**CON 2 GRIGLIE CM.65X71 GN2/1 (INCLUSA 1**  
**TESTATA CHIUSURA PIANO MOD.TPA-9)**

**EN** Electric range - N. 8 plates - 2 Traditional electric oven cm. 67x73x34h, temp: 50÷300°C, with 2 grids cm.65x71 GN2/1 (included 1 Head end filler strip mod.TPA-9)  
• **DE** Elektroherd - N. 8 Kochplatten - 2 Statischer Elektro-Backofen cm. 67x73x34h, temp: 50÷300°C, mit 2 Rost cm.65x71 GN2/1 (inbegriffen 1 Abschluss-Element mod.TPA-9)  
• **FR** Fourneau électrique - N. 8 plaques - 2 Four électrique statique cm. 67x73x34h, temp: 50÷300°C, avec 2 grille cm.65x71 GN2/1 (inclus 1 Élément de jonction top mod.TPA-9)  
• **ES** Cocina eléctrica - N. 8 planchas - 2 Horno eléctrico estático cm. 67x73x34h, temp: 50÷300°C, con 2 parilla cm.65x71 GN2/1 (incluida 1 Chapa de cierre para top mod.TPA-9)  
**cm. 160x 90x 90h**



⚡ 41,4 kW kcal/h **7.756,00**  
400V~3N 246 / 1,96  
50/60 Hz

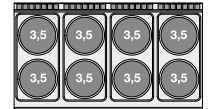

**CFQ8-916ET**  
09661633

**CUCINA 8 PIASTRE QUADRE- 2 FORNI**  
**ELETTRICI STATICI CM. 67X73X34H, TEMP:**  
**50÷300°C, CON 2 GRIGLIE CM.65X71 GN2/1**  
**(INCLUSA 1 TESTATA CHIUSURA PIANO MOD.**  
**TPA-9)**

**EN** Electric range - N. 8 square plates - 2 Traditional electric oven cm. 67x73x34h, temp: 50÷300°C, with 2 grids cm.65x71 GN2/1 (included 1 Head end filler strip mod.TPA-9)  
• **DE** Elektroherd - N. 8 quadratischen Platte - 2 Statischer Elektro-Backofen cm. 67x73x34h, temp: 50÷300°C, mit 2 Rost cm.65x71 GN2/1 (inbegriffen 1 Abschluss-Element mod.TPA-9)  
• **FR** Fourneau électrique - N. 8 plaques carrés - 2 Four électrique statique cm. 67x73x34h, temp: 50÷300°C, avec 2 grille cm.65x71 GN2/1 (inclus 1 Élément de jonction top mod.TPA-9)  
• **ES** Cocina eléctrica - N. 8 planchas cuadradas - 2 Horno eléctrico estático cm. 67x73x34h, temp: 50÷300°C, con 2 parilla cm.65x71 GN2/1 (incluida 1 Chapa de cierre para top mod.TPA-9)  
**cm. 160x 90x 90h**



⚡ 45,4 kW kcal/h **9.146,00**  
400V~3N 266 / 1,96  
50/60 Hz





MOD. \_\_\_\_\_  
COD. \_\_\_\_\_

DESCRIZIONE/DESCRIPTION/BEZEICHNUNG/DESCRIPCIÓN  
DIMENSIONI/DIMENSIONS/ABMESSUNGEN/DIMENSIONS/DIMENSIONES

POTENZA/POWER/LEISTUNG/PUISSANCE/POTENCIA  
VOLTAGGIO/VOLTAGE/SPANNUNG/VOLTAGE/VOLTAJE

⚡ kW \_\_\_\_\_  
kcal/h \_\_\_\_\_  
V~ \_\_\_\_\_  
Hz \_\_\_\_\_

PREZZO/PRICE € \_\_\_\_\_  
PREIS/PRIX/PRECIO € \_\_\_\_\_  
KG / M<sup>3</sup> \_\_\_\_\_

**CF8-916G**  
09681650

**CUCINA 8 FUOCHI - 2 FORNI GAS STATICI**  
**CM. 67X73X34H, TEMP: 150÷300°C, CON**  
**2 GRIGLIE CM.65X71 GN2/1 (INCLUSA 1**  
**TESTATA CHIUSURA PIANO MOD.TPC-9)**  
**EN** Gas Range - N. 8 burners - 2 Traditional gas-oven cm. 67x73x34h, temp: 150÷300°C, with 2 grids cm.65x71 GN2/1 (included 1 Head end filler strip mod.TPC-9) • **DE** Gasherd - N. 8 Kochstellen - 2 Statischer Gas-Backofen cm. 67x73x34h, temp: 150÷300°C, mit 2 Rost cm.65x71 GN2/1 (inbegriffen 1 Abschluss-Element mod.TPC-9) • **FR** Cuisiniere gaz - N. 8 feux - 2 Four à gaz statique cm. 67x73x34h, temp: 150÷300°C, avec 2 grille cm.65x71 GN2/1 (inclus 1 Élément de jonction top mod.TPC-9) • **ES** Cocina a gas - N. 8 quemadores - 2 Horno a gas estático cm. 67x73x34h, temp: 150÷300°C, con 2 parilla cm.65x71 GN2/1 (incluida 1 Chapa de cierre para top mod.TPC-9)  
**cm. 160x 90x 90h**



⚡ 73 kW \_\_\_\_\_ **7.629,00**  
62.780 kcal/h 318 / 1,96

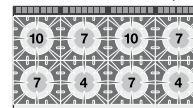

**CF8-916GE**  
09691660

**CUCINA 8 FUOCHI - 2 FORNI ELETTRICI STATICI**  
**CM. 67X73X34H, TEMP: 50÷300°C, CON**  
**2 GRIGLIE CM.65X71 GN2/1 (INCLUSA 1**  
**TESTATA CHIUSURA PIANO MOD.TPC-9)**  
**EN** Gas Range - N. 8 burners - 2 Traditional electric oven cm. 67x73x34h, temp: 50÷300°C, with 2 grids cm.65x71 GN2/1 (included 1 Head end filler strip mod.TPC-9) • **DE** Gasherd - N. 8 Kochstellen - 2 Statischer Elektro-Backofen cm. 67x73x34h, temp: 50÷300°C, mit 2 Rost cm.65x71 GN2/1 (inbegriffen 1 Abschluss-Element mod.TPC-9) • **FR** Cuisiniere gaz - N. 8 feux - 2 Four électrique statique cm. 67x73x34h, temp: 50÷300°C, avec 2 grille cm.65x71 GN2/1 (inclus 1 Élément de jonction top mod.TPC-9) • **ES** Cocina a gas - N. 8 quemadores - 2 Horno eléctrico estático cm. 67x73x34h, temp: 50÷300°C, con 2 parilla cm.65x71 GN2/1 (incluida 1 Chapa de cierre para top mod.TPC-9)  
**cm. 160x 90x 90h**



⚡ 56 kW \_\_\_\_\_ **7.799,00**  
48.160 kcal/h 312 / 1,96

⚡ 13,4 kW \_\_\_\_\_  
400V~3N \_\_\_\_\_  
50/60 Hz \_\_\_\_\_

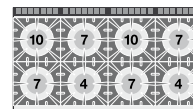

**CF8-916ETV**  
09661630

**CUCINA 8 PIASTRE FORNO ELETTRICO STATICO**  
**CM. 107X73X34H, TEMP: 50÷300°C, CON 1**  
**GRIGLIA CM.105X71 - VANO NEUTRO CON**  
**PORTA (INCLUSA 1 TESTATA CHIUSURA PIANO**  
**MOD.TPA-9)**

**EN** Electric Range - N. 8 plates Traditional electric oven cm. 107x73x34h, temp: 50÷300°C, with 1 grid cm.105x71 - Neutral cabinet with door (included 1 Head end filler strip mod.TPA-9) • **DE** Elektroherd - N. 8 Kochplatten Statischer Elektro-Backofen cm. 107x73x34h, temp: 50÷300°C, mit 1 Rost cm.105x71 - Neutrales Schrankelement mit Tür (inbegriffen 1 Abschluss-Element mod.TPA-9) • **FR** Fourneau électrique - N. 8 plaques Four électrique statique cm. 107x73x34h, temp: 50÷300°C, avec 1 grille cm.105x71 - Élément neutre avec porte (inclus 1 Élément de jonction top mod.TPA-9) • **ES** Cocina eléctrica - N. 8 planchas Horno eléctrico estático cm. 107x73x34h, temp: 50÷300°C, con 1 parilla cm.105x71 - Armario neutro con puerta (incluida 1 Chapa de cierre para top mod.TPA-9)  
**cm. 160x 90x 90h**



⚡ 37,2 kW \_\_\_\_\_ **7.304,00**  
400V~3N \_\_\_\_\_ 234 / 1,96  
50/60 Hz \_\_\_\_\_

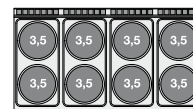

MOD. \_\_\_\_\_  
COD. \_\_\_\_\_

DESCRIZIONE/DESCRIPTION/BEZEICHNUNG/DESCRIPTION/DESCRIPCIÓN  
DIMENSIONI/DIMENSIONS/ABMESSUNGEN/DIMENSIONS/DIMENSIONES

POTENZA/POWER/LEISTUNG/PUISSANCE/POTENCIA  
VOLTAGGIO/VOLTAGE/SPANNUNG/VOLTAGE/VOLTAJE

⚡ kW  
kcal/h

PREZZO/PRICE €  
PREIS/PRIX/PRECIO €  
KG / M<sup>3</sup>

**CFQ8-916TV CUCINA 8 PIASTRE QUADRE FORNO  
ELETTRICO STATICO CM. 107X73X34H, TEMP:  
50÷300°C, CON 1 GRIGLIA CM.105X71 -**

09661631

**VANO NEUTRO CON PORTA (INCLUSA 1  
TESTATA CHIUSURA PIANO MOD.TPA-9)**  
**EN** Electric Range - N. 8 square plates - Traditional  
electric oven cm. 107x73x34h, temp: 50÷300°C,  
with 1 grid cm.105x71 - Neutral cabinet with door  
(included 1 Head end filler strip mod.TPA-9) • **DE**  
Elektroherd - N. 8 quadratischen Platten - Statischer  
Elektro-Backofen cm. 107x73x34h, temp: 50÷300°C,  
mit 1 Rost cm.105x71 - Neutrales Schrankelement  
mit Tür (inbegriffen 1 Abschluss-Element mod.TPA-9)  
• **FR** Fourneau électrique - N. 8 plaques carrés - Four  
électrique statique cm. 107x73x34h, temp: 50÷300°C,  
avec 1 grille cm.105x71 - Élément neutre avec porte  
(inclus 1 Élément de jonction top mod.TPA-9) • **ES**  
Cocina eléctrica - N. 8 planchas cuadradas - Horno  
eléctrico estático cm. 107x73x34h, temp: 50÷300°C,  
con 1 parilla cm.105x71 - Armario neutro con puerta  
(incluida 1 Chapa de cierre para top mod.TPA-9)  
**cm. 160x 90x 90h**



⚡ 41,2 kW **8.687,00**  
400V~3N 254 / 1,96  
50/60 Hz

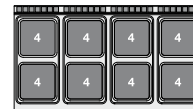

**CF8-916GV CUCINA 8 FUOCHI FORNO A GAS STATICO  
CM. 107X73X34H, TEMP: 150÷300°C, CON  
1 GRIGLIA CM.105X71 - VANO NEUTRO CON  
PORTA (INCLUSA 1 TESTATA CHIUSURA PIANO  
MOD.TPC-9)**

09681651

**EN** Gas Range - N. 8 burners Traditional gas-oven  
cm. 107x73x34h, temp: 150÷300°C, with 1 grid  
cm.105x71 - Neutral cabinet with door (included 1  
Head end filler strip mod.TPC-9) • **DE** Gasherd - N. 8  
Kochstellen Statischer Gas-Backofen cm. 107x73x34h,  
temp: 150÷300°C, mit 1 Rost cm.105x71 - Neutrales  
Schrankelement mit Tür (inbegriffen 1 Abschluss-Element  
mod.TPC-9) • **FR** Cuisinière gaz - N. 8 feux vifs Four  
à gaz statique cm. 107x73x34h, temp: 150÷300°C,  
avec 1 grille cm.105x71 - Élément neutre avec porte  
(inclus 1 Élément de jonction top mod.TPC-9) • **ES**  
Cocina a gas - N. 8 quemadores Horno a gas estático  
cm. 107x73x34h, temp: 150÷300°C, con 1 parilla  
cm.105x71 - Armario neutro con puerta equipado  
(incluida 1 Chapa de cierre para top mod.TPC-9)  
**cm. 160x 90x 90h**



⚡ 69 kW **7.342,00**  
59.270 kcal/h 306 / 1,96

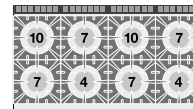

**CF8-916GEV CUCINA 8 FUOCHI FORNO ELETTRICO STATICO  
CM. 107X73X34H, TEMP: 50÷300°C, CON  
1 GRIGLIA CM.105X71 - VANO NEUTRO  
CON PORTA (INCLUSA 1 TESTATA CHIUSURA  
PIANO MOD.TPC-9)**

09691661

**EN** Gas Range - N. 8 burners Traditional electric  
oven cm. 107x73x34h, temp: 50÷300°C, with 1  
grid cm.105x71 - neutral cabinet with door (included  
1 Head end filler strip mod.TPC-9) • **DE** Gasherd  
- N. 8 Kochstellen Statischer Elektro-Backofen cm.  
107x73x34h, temp: 50÷300°C, mit 1 Rost cm.105x71  
- Neutrales Schrankelement mit Tür (inbegriffen 1  
Abschluss-Element mod.TPC-9) • **FR** Cuisiniere gaz - N.  
8 feux vifs Four électrique statique cm. 107x73x34h,  
temp: 50÷300°C, avec 1 grille cm.105x71 - élément  
neutre avec porte (inclus 1 Élément de jonction top mod.  
TPC-9) • **ES** Cocina a gas - N. 8 quemadores Horno  
eléctrico estático cm. 107x73x34h, temp: 50÷300°C,  
con 1 parilla cm.105x71 - armario neutro con puerta  
(incluida 1 Chapa de cierre para top mod.TPC-9)  
**cm. 160x 90x 90h**



⚡ 56 kW **7.447,00**  
48.160 kcal/h 299 / 1,96

⚡ 9,2 kW  
400V~3N  
50/60 Hz

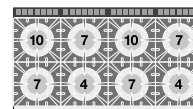

# PIANI COTTURA ELETTRICI

MOD. \_\_\_\_\_  
COD. \_\_\_\_\_

DESCRIZIONE/DESCRIPTION/BEZEICHNUNG/DESCRIPTION/DESCRIPCIÓN  
DIMENSIONI/DIMENSIONS/ABMESSUNGEN/DIMENSIONS/DIMENSIONES

POTENZA/POWER/LEISTUNG/PUISSANCE/POTENCIA  
VOLTAGGIO/VOLTAGE/SPANNUNG/VOLTAGE/VOLTAJE

⚡ kW \_\_\_\_\_  
kcal/h \_\_\_\_\_  
V~ \_\_\_\_\_  
Hz \_\_\_\_\_

PREZZO/PRICE € \_\_\_\_\_  
PREIS/PRIX/PRECIO \_\_\_\_\_  
KG / M<sup>3</sup> \_\_\_\_\_

**PC-94ET**  
09030430

**PIANO COTTURA TRIFASE SU MOBILE A GIORNO - N. 2 PIASTRE (INCLUSA 1 TESTATA CHIUSURA PIANO MOD.TPA-9)**

**EN** Boiling unit threephase on open cabinet - N. 2 plates (included 1 Head end filler strip mod.TPA-9)  
• **DE** Kochplatte dreiphasig mit offenem Unterbau - N. 2 Kochplatten (inbegriffen 1 Abschluss-Element mod. TPA-9) • **FR** Rechaud électriques sur armoire ouvert - N. 2 plaques (inclus 1 Élément de jonction top mod.TPA-9)  
• **ES** Sobre de cocción trifásico sobre mueble abierto - N. 2 planchas (incluida 1 Chapa de cierre para top mod.TPA-9)  
**cm. 40x 90x 90h**



⚡ 7,0 kW \_\_\_\_\_ **1.418,00**  
400V~2N \_\_\_\_\_ 53 / 0,46  
230V~3  
230V~  
50/60 Hz



**PC-98ET**  
09030830

**PIANO COTTURA TRIFASE SU MOBILE A GIORNO N. 4 PIASTRE (INCLUSA 1 TESTATA CHIUSURA PIANO MOD.TPA-9)**

**EN** Threephase boiling unit on open cabinet - N. 4 plates (included 1 Head end filler strip mod.TPA-9)  
• **DE** Kochplatte dreiphasig mit offenem Unterbau N. 4 Kochplatten (inbegriffen 1 Abschluss-Element mod. TPA-9) • **FR** Rechaud triphase sur armoire ouvert - N. 4 plaques (inclus 1 Élément de jonction top mod.TPA-9)  
• **ES** Sobre de cocción trifásico sobre mueble abierto N. 4 planchas (incluida 1 Chapa de cierre para top mod. TPA-9)  
**cm. 80x 90x 90h**



⚡ 14,0 kW \_\_\_\_\_ **2.629,00**  
400V~3N \_\_\_\_\_ 86 / 0,89  
50/60 Hz



**PC-912ET**  
09031230

**PIANO COTTURA TRIFASE SU MOBILE A GIORNO N. 6 PIASTRE (INCLUSA 1 TESTATA CHIUSURA PIANO MOD.TPA-9)**

**EN** Threephase boiling unit on open cabinet - N. 6 plates (included 1 Head end filler strip mod.TPA-9)  
• **DE** Kochplatte dreiphasig mit offenem Unterbau N. 6 Kochplatten (inbegriffen 1 Abschluss-Element mod. TPA-9) • **FR** Rechaud triphase sur armoire ouvert - N. 6 plaques (inclus 1 Élément de jonction top mod.TPA-9)  
• **ES** Sobre de cocción trifásico sobre mueble abierto N. 6 planchas (incluida 1 Chapa de cierre para top mod. TPA-9)  
**cm. 120x 90x 90h**



⚡ 21,0 kW \_\_\_\_\_ **3.585,00**  
400V~3N \_\_\_\_\_ 114 / 1,32  
50/60 Hz

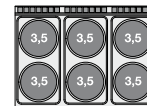

**PC-916ET**  
09031630

**PIANO COTTURA TRIFASE SU MOBILE A GIORNO - N. 8 PIASTRE (INCLUSA 1 TESTATA CHIUSURA PIANO MOD.TPA-9)**

**EN** Threephase boiling unit on open cabinet - N. 8 plates (included 1 Head end filler strip mod.TPA-9)  
• **DE** Kochplatte dreiphasig mit offenem Unterbau N. 8 Kochplatten (inbegriffen 1 Abschluss-Element mod. TPA-9) • **FR** Rechaud triphase sur armoire ouvert - N. 8 plaques (inclus 1 Élément de jonction top mod.TPA-9)  
• **ES** Sobre de cocción trifásico sobre mueble abierto N. 8 planchas (incluida 1 Chapa de cierre para top mod. TPA-9)  
**cm. 160x 90x 90h**



⚡ 28 kW \_\_\_\_\_ **4.515,00**  
400V~3N \_\_\_\_\_ 154 / 1,96  
50/60 Hz



**PCQ-94ET**  
09030431

**PIANO COTTURA TRIFASE SU MOBILE A GIORNO - N. 2 PIASTRE QUADRE (INCLUSA 1 TESTATA CHIUSURA PIANO MOD.TPA-9)**

**EN** Boiling unit threephase on open cabinet - N. 2 square plates (included 1 Head end filler strip mod.TPA-9)  
• **DE** Kochplatte dreiphasig mit offenem Unterbau N. 2 quadratischen Platten (inbegriffen 1 Abschluss-Element mod.TPA-9) • **FR** Rechaud électriques sur armoire ouvert - N. 2 plaques carrés (inclus 1 Élément de jonction top mod.TPA-9) • **ES** Sobre de cocción trifásico sobre mueble abierto N. 2 planchas cuadradas (incluida 1 Chapa de cierre para top mod.TPA-9)  
**cm. 40x 90x 90h**



⚡ 8,0 kW \_\_\_\_\_ **1.868,00**  
400V~2N \_\_\_\_\_ 57 / 0,46  
230V~3  
230V~  
50/60 Hz



# PIANI COTTURA ELETTRICI

MOD. \_\_\_\_\_  
COD. \_\_\_\_\_

DESCRIZIONE/DESCRIPTION/BEZEICHNUNG/DESCRIPTION/DESCRIPCIÓN  
DIMENSIONI/DIMENSIONS/ABMESSUNGEN/DIMENSIONS/DIMENSIONES

POTENZA/POWER/LEISTUNG/PUISSANCE/POTENCIA  
VOLTAGGIO/VOLTAGE/SPANNUNG/VOLTAGE/VOLTAJE

⚡ kW  
kcal/h  
V~  
Hz

PREZZO/PRICE €  
PREIS/PRIX/PRECIO €  
KG / M<sup>3</sup>

**PQC-98ET**  
09030831

**PIANO COTTURA TRIFASE SU MOBILE A GIORNO - N. 4 PIASTRE QUADRE (INCLUSA 1 TESTATA CHIUSURA PIANO MOD.TPA-9)**  
**EN** Boiling unit threephase on open cabinet - N. 4 square plates (included 1 Head end filler strip mod.TPA-9) • **DE** Kochplatte dreiphasig mit offenem Unterbau N. 4 quadratischen Platten (inbegriffen 1 Abschluss-Element mod.TPA-9) • **FR** Rechaud électriques sur armoire ouvert - N. 4 plaques carrés (inclus 1 Élément de jonction top mod.TPA-9) • **ES** Sobre de cocción trifásico sobre mueble abierto N. 4 planchas cuadradas (incluida 1 Chapa de cierre para top mod.TPA-9)  
**cm. 80x 90x 90h**



⚡ 16,0 kW  
400V~3N  
50/60 Hz

**3.376,00**  
94 / 0,89



**PQC-912ET**  
09031231

**PIANO COTTURA TRIFASE SU MOBILE A GIORNO - N. 6 PIASTRE QUADRE (INCLUSA 1 TESTATA CHIUSURA PIANO MOD.TPA-9)**  
**EN** Boiling unit threephase on open cabinet - N. 6 square plates (included 1 Head end filler strip mod.TPA-9) • **DE** Kochplatte dreiphasig mit offenem Unterbau N. 6 quadratischen Platten (inbegriffen 1 Abschluss-Element mod.TPA-9) • **FR** Rechaud électriques sur armoire ouvert - N. 6 plaques carrés (inclus 1 Élément de jonction top mod.TPA-9) • **ES** Sobre de cocción trifásico sobre mueble abierto N. 6 planchas cuadradas (incluida 1 Chapa de cierre para top mod.TPA-9)  
**cm. 120x 90x 90h**



⚡ 24,0 kW  
400V~3N  
50/60 Hz

**4.649,00**  
129 / 1,32



**PQC-916ET**  
09031631

**PIANO COTTURA TRIFASE SU MOBILE A GIORNO - N. 8 PIASTRE QUADRE (INCLUSA 1 TESTATA CHIUSURA PIANO MOD.TPA-9)**  
**EN** Boiling unit threephase on open cabinet - N. 8 square plates (included 1 Head end filler strip mod.TPA-9) • **DE** Kochplatte dreiphasig mit offenem Unterbau N. 8 quadratischen Platten (inbegriffen 1 Abschluss-Element mod.TPA-9) • **FR** Rechaud électriques sur armoire ouvert - N. 8 plaques carrés (inclus 1 Élément de jonction top mod.TPA-9) • **ES** Sobre de cocción trifásico sobre mueble abierto N. 8 planchas cuadradas (incluida 1 Chapa de cierre para top mod.TPA-9)  
**cm. 160x 90x 90h**



⚡ 32 kW  
400V~3N  
50/60 Hz

**6.013,00**  
170 / 1,96



**PCC-94ET**  
09030432

**PIANO COTTURA VETROCERAMICA TRIFASE SU MOBILE A GIORNO - N. 2 ZONE - VETRO CM.35X77 (INCLUSA 1 TESTATA CHIUSURA PIANO MOD.TPA-9)**  
**EN** Ceramic glass boiling unit on open cabinet - n. 2 zones - glass cm.35x77 (included 1 Head end filler strip mod.TPA-9) • **DE** Ceran-Kochplatte dreiphasig mit offenem Unterbau - 2 zonen - Glas 35x77 cm (inbegriffen 1 Abschluss-Element mod.TPA-9) • **FR** Plan de cuisson à vitroceramique triphasé sur armoire ouvert N. 2 zones - Verre cm.35x77 (inclus 1 Élément de jonction top mod.TPA-9) • **ES** Sobre de cocción trifásico vitrocerámica sobre mueble abierto - 2 zonas - vidrio cm.35x77 (incluida 1 Chapa de cierre para top mod.TPA-9)  
**cm. 40x 90x 90h**



⚡ 6,8 kW  
400V~2N  
230V~3  
230V~  
50/60 Hz

**2.349,00**  
48 / 0,46

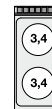

Le immagini presentate non sono vincolanti. La ditta si riserva di apportare modifiche senza preavviso. • The pictures are purely representative. The manufacturer reserves the right to modify the technical data and models without previous notice. • Les images

LO

présentées ne nous engagent pas. La Société se réserve le droit d'apporter tout modification sans préavis. • Die dargestellten Abbildungen sind nicht verbindlich. Technische Änderungen vorbehalten. • Las imágenes presentadas no son vinculantes. El Fabricante se reserva el derecho de modificar sus productos sin previo aviso.

01/20

237

90



# PIANI COTTURA ELETTRICI

MOD. \_\_\_\_\_  
COD. \_\_\_\_\_

DESCRIZIONE/DESCRIPTION/BEZEICHNUNG/DESCRIPTION/DESCRIPCIÓN  
DIMENSIONI/DIMENSIONS/ABMESSUNGEN/DIMENSIONS/DIMENSIONES

POTENZA/POWER/LEISTUNG/PUISSANCE/POTENCIA  
VOLTAGGIO/VOLTAGE/SPANNUNG/VOLTAGE/VOLTAJE

⚡ kcal/h    ⚡ kW  
V~    Hz

PREZZO/PRICE €  
PREIS/PRIX/PRECIO €  
KG / M<sup>3</sup>

**PCC-98ET**  
09030832

**PIANO COTTURA VETROCERAMICA TRIFASE SU MOBILE A GIORNO - N. 4 ZONE - VETRO CM. 75X77 (INCLUSA 1 TESTATA CHIUSURA PIANO MOD.TPA-9)**

**EN** Ceramic glass boiling unit on open cabinet - n. 4 zones - glass cm. 75 x 77 (included 1 Head end filler strip mod.TPA-9) • **DE** Ceran-Kochplatte dreiphasig mit offenem Unterbau - 4 zonen - Glas 75x77 cm (inbegriffen 1 Abschluss-Element mod.TPA-9) • **FR** Plan de cuisson à vitroceramique triphasé sur armoire ouvert N. 4 zones - Verre cm 75x77 (inclus 1 Élément de jonction top mod.TPA-9) • **ES** Sobre de cocción trifásico vitrocerámica sobre mueble abierto - 4 zonas - vidrio cm. 75 x 77 (incluida 1 Chapa de cierre para top mod. TPA-9)

**cm. 80x 90x 90h**



⚡ 13,6 kW    **3.782,00**  
400V~3N    74 / 0,89  
230V~3  
50/60 Hz



**PCI-94ET**  
09030433

**PIANO COTTURA INDUZIONE TRIFASE - N. 2 ZONE - VETRO CM.35X77 (INCLUSA 1 TESTATA CHIUSURA PIANO MOD.TPA-9)**

**EN** Three-phase induction cooking - 2 zones - glass cm.35x77 (included 1 Head end filler strip mod.TPA-9) • **DE** Induktions-Kochplatte dreiphasig - 2 zonen - Glas 35x77 cm (inbegriffen 1 Abschluss-Element mod.TPA-9) • **FR** Plan de cuisson à induction triphasé N. 2 zones - Verre cm.35x77 (inclus 1 Élément de jonction top mod. TPA-9) • **ES** Encimera inducción trifásica - 2 zonas - Vidrio cm.35x77 (incluida 1 Chapa de cierre para top mod.TPA-9)

**cm. 40x 90x 90h**



⚡ 10 kW    **7.158,00**  
400V~3    57 / 0,46  
50/60 Hz

**PCI-94ETD**  
09030438

**PIANO COTTURA INDUZIONE TRIFASE - N. 2 ZONE - VETRO CM.35X77 - COMANDI DIGITALI (INCLUSA 1 TESTATA CHIUSURA PIANO MOD.TPA-9)**

**EN** Three-phase induction cooking - 2 zones - glass cm.35x77 - digital controls (included 1 Head end filler strip mod.TPA-9) • **DE** Induktions-Kochplatte dreiphasig - 2 zonen - Glas 35x77 cm - digitale Steuerungen (inbegriffen 1 Abschluss-Element mod.TPA-9) • **FR** Plan de cuisson à induction triphasé N. 2 zones - Verre cm.35x77 - commandes numériques (inclus 1 Élément de jonction top mod.TPA-9) • **ES** Encimera inducción trifásica - 2 zonas - Vidrio cm.35x77 - controles digitales (incluida 1 Chapa de cierre para top mod. TPA-9)

**cm. 40x 90x 90h**



⚡ 10 kW    **7.655,00**  
400V~3    57 / 0,46  
50/60 Hz

**PCIW-94ET**  
09030434

**PIANO COTTURA INDUZIONE TRIFASE "WOK" - N. 1 ZONA - VETRO Ø 30 CM. (INCLUSA 1 TESTATA CHIUSURA PIANO MOD.TPA-9)**

**EN** Three-phase induction cooking "WOK" - 1 zone - glass Ø 30 cm (included 1 Head end filler strip mod. TPA-9) • **DE** Induktions-Kochplatte "WOK" dreiphasig - 1 zonen - Glas Ø 30 cm (inbegriffen 1 Abschluss-Element mod.TPA-9) • **FR** Plan de cuisson à induction "WOK" triphasé N. 1 zone - Verre cm Ø 30 (inclus 1 Élément de jonction top mod.TPA-9) • **ES** Encimera inducción "WOK" trifásica - 1 zona - Vidrio Ø 30 cm (incluida 1 Chapa de cierre para top mod.TPA-9)

**cm. 40x 90x 90h**



⚡ 5 kW    **5.373,00**  
400V~3    53 / 0,46  
50/60 Hz



# PIANI COTTURA A INDUZIONE

MOD. \_\_\_\_\_  
COD. \_\_\_\_\_

DESCRIZIONE/DESCRIPTION/BEZEICHNUNG/DESCRIPTION/DESCRIPCIÓN  
DIMENSIONI/DIMENSIONS/ABMESSUNGEN/DIMENSIONS/DIMENSIONES

POTENZA/POWER/LEISTUNG/PUISSANCE/POTENCIA  
VOLTAGGIO/VOLTAGE/SPANNUNG/VOLTAGE/VOLTAJE

⚡ kW kcal/h  
V~ Hz

PREZZO/PRICE €  
PREIS/PRIX/PRECIO €  
KG / M<sup>3</sup>

## PCIW-94ETD PIANO COTTURA INDUZIONE TRIFASE "WOK"

09030439

**- N. 1 ZONA - VETRO Ø 30 CM. - COMANDI DIGITALI (INCLUSA 1 TESTATA CHIUSURA PIANO MOD.TPA-9)**

**EN** Three-phase induction cooking "WOK" - 1 zone - glass Ø 30 cm - digital controls (included 1 Head end filler strip mod.TPA-9) • **DE** Induktions-Kochplatte "WOK" dreiphasig - 1 zonen - Glas Ø 30 cm - digitale Steuerungen (inbegriffen 1 Abschluss-Element mod.TPA-9) • **FR** Plan de cuisson à induction "WOK" triphasé N. 1 zone - Verre cm Ø 30 - commandes numériques (inclus 1 Élément de jonction top mod.TPA-9) • **ES** Encimera inducción "WOK" trifásica - 1 zona - Vidrio Ø 30 cm - controles digitales (incluida 1 Chapa de cierre para top mod.TPA-9)

**cm. 40x 90x 90h**



⚡ 5 kW 5.622,00  
400V~3 53 / 0,46  
50/60 Hz

## PCI-98ET

09030833

**PIANO COTTURA INDUZIONE TRIFASE - N. 4 ZONE - VETRO CM.75X77 (INCLUSA 1 TESTATA CHIUSURA PIANO MOD.TPA-9)**

**EN** Three-phase induction cooking - 4 zones - glass cm.75x77 (included 1 Head end filler strip mod.TPA-9) • **DE** Induktions-Kochplatte dreiphasig - 4 zonen - Glas 75x77 cm (inbegriffen 1 Abschluss-Element mod.TPA-9) • **FR** Plan de cuisson à induction triphasé N. 4 zones - Verre cm.75x77 (inclus 1 Élément de jonction top mod.TPA-9) • **ES** Encimera inducción trifásica - 4 zonas - Vidrio cm.75x77 (incluida 1 Chapa de cierre para top mod.TPA-9)

**cm. 80x 90x 90h**



⚡ 20,0 kW 13.659,00  
400V~3 94 / 0,89  
50/60 Hz

## PCI-98ETD

09030838

**PIANO COTTURA INDUZIONE TRIFASE - N. 4 ZONE - VETRO CM.75X77 - COMANDI DIGITALI (INCLUSA 1 TESTATA CHIUSURA PIANO MOD.TPA-9)**

**EN** Three-phase induction cooking - 4 zones - glass cm.75x77 - digital controls (included 1 Head end filler strip mod.TPA-9) • **DE** Induktions-Kochplatte dreiphasig - 4 zonen - Glas 75x77 cm - digitale Steuerungen (inbegriffen 1 Abschluss-Element mod.TPA-9) • **FR** Plan de cuisson à induction triphasé N. 4 zones - Verre cm.75x77 - commandes numériques (inclus 1 Élément de jonction top mod.TPA-9) • **ES** Encimera inducción trifásica - 4 zonas - Vidrio cm.75x77 - controles digitales (incluida 1 Chapa de cierre para top mod.TPA-9)

**cm. 80x 90x 90h**



⚡ 20,0 kW 14.654,00  
400V~3 94 / 0,89  
50/60 Hz

## PC-94G

09210450

**PIANO COTTURA GAS SU MOBILE A GIORNO 2 FUOCHI (INCLUSA 1 TESTATA CHIUSURA PIANO MOD.TPC-9)**

**EN** Gas heated boiling unit on open cabinet - 2 burners (included 1 Head end filler strip mod.TPC-9) • **DE** Gas-kochplatte mit offenem Unterbau - 2 Kochstellen (inbegriffen 1 Abschluss-Element mod.TPC-9) • **FR** Rechaud gaz sur armoire ouvert - 2 feux vifs (inclus 1 Élément de jonction top mod.TPC-9) • **ES** Sobres de cocción gas sobre mueble abierto - 2 quemadores (incluida 1 Chapa de cierre para top mod.TPC-9)

**cm. 40x 90x 90h**



⚡ 11 kW 1.651,00  
9.460 kcal/h 71 / 0,46



## PC-98G

09210850

**PIANO COTTURA GAS SU MOBILE A GIORNO 4 FUOCHI (INCLUSA 1 TESTATA CHIUSURA PIANO MOD.TPC-9)**

**EN** Gas heated boiling unit on open cabinet - 4 burners (included 1 Head end filler strip mod.TPC-9) • **DE** Gas-Kochplatte mit offenem Unterbau - 4 Kochstellen (inbegriffen 1 Abschluss-Element mod.TPC-9) • **FR** Rechaud gaz sur armoire ouvert - 4 feux vifs (inclus 1 Élément de jonction top mod.TPC-9) • **ES** Sobres de cocción gas sobre mueble abierto - 4 quemadores (incluida 1 Chapa de cierre para top mod.TPC-9)

**cm. 80x 90x 90h**



⚡ 28 kW 2.633,00  
24.080 kcal/h 100 / 0,89

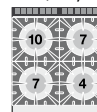

Le immagini presentate non sono vincolanti. La ditta si riserva di apportare modifiche senza preavviso. • The pictures are purely representative. The manufacturer reserves the right to modify the technical data and models without previous notice. • Les images

LO

présentées ne nous engagent pas. La Société se réserve le droit d'apporter tout modification sans préavis. • Die dargestellten Abbildungen sind nicht verbindlich. Technische Änderungen vorbehalten. • Las imágenes presentadas no son vinculantes. El Fabricante se reserva el derecho de modificar sus productos sin previo aviso.

01/20

239

90

# PIANI COTTURA A GAS

MOD. \_\_\_\_\_  
COD. \_\_\_\_\_

DESCRIZIONE/DESCRIPTION/BEZEICHNUNG/DESCRIPTION/DESCRIPCIÓN  
DIMENSIONI/DIMENSIONS/ABMESSUNGEN/DIMENSIONS/DIMENSIONES

POTENZA/POWER/LEISTUNG/PUISSANCE/POTENCIA  
VOLTAGGIO/VOLTAGE/SPANNUNG/VOLTAGE/VOLTAJE

⚡ kW  
kcal/h

⚡ kW  
V~  
Hz

PREZZO/PRICE €  
PREIS/PRIX/PRECIO €  
KG / M<sup>3</sup>

**PC-912G**  
09211250

**PIANO COTTURA GAS SU MOBILE A GIORNO  
6 FUOCHI (INCLUSA 1 TESTATA CHIUSURA  
PIANO MOD.TPC-9)**

**EN** Gas heated boiling unit on open cabinet - 6 burners (included 1 Head end filler strip mod.TPC-9) • **DE** Gas-Kochplatte mit offenem Unterbau - 6 Kochstellen (inbegriffen 1 Abschluss-Element mod.TPC-9) • **FR** Rechaud gaz sur armoire ouvert - 6 feux vifs (inclus 1 Élément de jonction top mod.TPC-9) • **ES** Sobres de cocción gas sobre mueble abierto - 6 quemadores (incluida 1 Chapa de cierre para top mod.TPC-9)  
**cm. 120x 90x 90h**



⚡ 45 kW  
38.700 kcal/h

**3.807,00**  
142 / 1,32

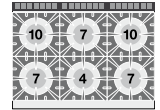

**PC-916G**  
09211650

**PIANO COTTURA GAS SU MOBILE A GIORNO  
- 8 FUOCHI (INCLUSA 1 TESTATA CHIUSURA  
PIANO MOD.TPC-9)**

**EN** Gas heated boiling unit on open cabinet - 8 burners (included 1 Head end filler strip mod.TPC-9) • **DE** Gas-Kochplatte mit offenem Unterbau - 8 Kochstellen (inbegriffen 1 Abschluss-Element mod.TPC-9) • **FR** Rechaud gaz sur armoire ouvert - 8 feux vifs (inclus 1 Élément de jonction top mod.TPC-9) • **ES** Sobres de cocción gas sobre mueble abierto 8 quemadores (incluida 1 Chapa de cierre para top mod.TPC-9)  
**cm. 160x 90x 90h**



⚡ 56 kW  
48.160 kcal/h

**4.999,00**  
182 / 1,96

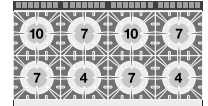

**PCA-94G**  
09310450

**PIANO COTTURA ACQUA SU MOBILE A  
GIORNO 2 FUOCHI - RUBINETTO CARICO  
ACQUA, SFIORATORE (INCLUSA 1 TESTATA  
CHIUSURA PIANO MOD.TPA-9)**

**EN** water heated boiling unit on open cabinet - 2 burners - Water loading tap + overflow device (included 1 Head end filler strip mod.TPA-9) • **DE** wasser-Kochplatte mit offenem Unterbau - 2 Kochstellen - Wasserlauf-Hahn + Überlauf-Vorrichtung (inbegriffen 1 Abschluss-Element mod.TPA-9) • **FR** Rechaud l'eau sur armoire ouvert - 2 feux vifs - Robinet d'arrivée d'eau trop plein (inclus 1 Élément de jonction top mod.TPA-9) • **ES** Sobres de cocción agua sobre mueble abierto 2 quemadores - Grifo carga agua + vertedero (incluida 1 Chapa de cierre para top mod.TPA-9)  
**cm. 40x 90x 90h**



⚡ 14 kW  
12.040 kcal/h

**2.085,00**  
71 / 0,46

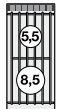

**PCA-98G**  
09310850

**PIANO COTTURA ACQUA SU MOBILE A  
GIORNO - 4 FUOCHI - RUBINETTO CARICO  
ACQUA, SFIORATORE (INCLUSA 1 TESTATA  
CHIUSURA PIANO MOD.TPA-9)**

**EN** water heated boiling unit on open cabinet - 4 burners - Water loading tap + overflow device (included 1 Head end filler strip mod.TPA-9) • **DE** wasser-kochplatte mit offenem Unterbau - 4 Kochstellen - Wasserlauf-Hahn + Überlauf-Vorrichtung (inbegriffen 1 Abschluss-Element mod.TPA-9) • **FR** Rechaud l'eau sur armoire ouvert - 4 feux vifs - Robinet d'arrivée d'eau trop plein (inclus 1 Élément de jonction top mod.TPA-9) • **ES** Sobres de cocción agua sobre mueble abierto 4 quemadores - Grifo carga agua + vertedero (incluida 1 Chapa de cierre para top mod.TPA-9)  
**cm. 80x 90x 90h**



⚡ 28 kW  
24.080 kcal/h

**3.344,00**  
100 / 0,89



# PIANI COTTURA AD ACQUA A GAS

MOD. \_\_\_\_\_  
COD. \_\_\_\_\_

DESCRIZIONE/DESCRIPTION/BEZEICHNUNG/DESCRIPTION/DESCRIPCIÓN  
DIMENSIONI/DIMENSIONS/ABMESSUNGEN/DIMENSIONS/DIMENSIONES

POTENZA/POWER/LEISTUNG/PUISSANCE/POTENCIA  
VOLTAGGIO/VOLTAGE/SPANNUNG/VOLTAGE/VOLTAJE

⚡ kW  
kcal/h

PREZZO/PRICE €  
PREIS/PRIX/PRECIO €  
KG / M<sup>3</sup>

**PCA-912G**  
09311250

**PIANO COTTURA ACQUA SU MOBILE A GIORNO 6 FUOCHI - RUBINETTO CARICO ACQUA, SFIORATORE (INCLUSA 1 TESTATA CHIUSURA PIANO MOD.TPA-9)**

EN water heated boiling unit on open cabinet - 6 burners - Water loading tap + overflow device (included 1 Head end filler strip mod.TPA-9) • DE wasser-kochplatte mit offenem Unterbau - 6 Kochstellen - Wasserlauf-Hahn + Überlauf-Vorrichtung (inbegriffen 1 Abschluss-Element mod.TPA-9) • FR Rechaud l'eau sur armoire ouvert - 6 feux vifs - Robinet d'arrivée d'eau trop plein (inclus 1 Élément de jonction top mod.TPA-9) • ES Sobres de cocción agua sobre mueble abierto 6 quemadores - Grifo carga agua + vertedero (incluida 1 Chapa de cierre para top mod.TPA-9)  
**cm. 120x 90x 90h**



⚡ 42 kW  
36.120 kcal/h

**4.828,00**  
142 / 1,32

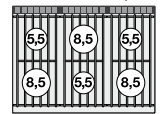

**PA-98G**  
09210851

**"PAELLERO" GAS SU MOBILE A GIORNO (INCLUSA 1 TESTATA CHIUSURA PIANO MOD.TPC-9)**

EN "PAELLERO" Gas - open cabinet (included 1 Head end filler strip mod.TPC-9) • DE "PAELLERO" Gas mit offenem Unterbau (inbegriffen 1 Abschluss-Element mod.TPC-9) • FR "PAELLERO" gaz sur armoire ouvert (inclus 1 Élément de jonction top mod.TPC-9) • ES "PAELLERO" gas sobre mueble abierto (incluida 1 Chapa de cierre para top mod.TPC-9)  
**cm. 80x 90x 90h**



⚡ 26,7 kW  
22.962 kcal/h

**3.744,00**  
134 / 0,89

**PAF-98G**  
09680851

**"PAELLERO" GAS SU FORNO GAS STATICO CM. 67X73X34H, TEMP: 150÷300°C, CON 1 GRIGLIA CM.65X71 GN2/1 (INCLUSA 1 TESTATA CHIUSURA PIANO MOD.TPC-9)**

EN "PAELLERO" Gas on Traditional gas-oven cm. 67x73x34h, temp: 150÷300°C, with 1 grid cm.65x71 GN2/1 (included 1 Head end filler strip mod.TPC-9) • DE "PAELLERO" Gas mit Statischer Gas-Backofen cm. 67x73x34h, temp: 150÷300°C, mit 1 Rost cm.65x71 GN2/1 (inbegriffen 1 Abschluss-Element mod.TPC-9) • FR "PAELLERO" gaz sur Four à gaz statique cm. 67x73x34h, temp: 150÷300°C, avec 1 grille cm.65x71 GN2/1 (inclus 1 Élément de jonction top mod.TPC-9) • ES "PAELLERO" gas sobre Horno a gas estático cm. 67x73x34h, temp: 150÷300°C, con 1 parilla cm.65x71 GN2/1 (incluida 1 Chapa de cierre para top mod.TPC-9)  
**cm. 80x 90x 90h**



⚡ 35,2 kW  
30.272 kcal/h

**4.942,00**  
184 / 0,89

**TP-94G**  
09290450

**TUTTA PIASTRA GAS SU MOBILE A GIORNO PIASTRA CM 39X73 (INCLUSA 1 TESTATA CHIUSURA PIANO MOD.TPC-9)**

EN Solid top on open unit - plate 39x73 cm (included 1 Head end filler strip mod.TPC-9) • DE Kochplatte auf offenem Unterbau - Platte 39x73 cm (inbegriffen 1 Abschluss-Element mod.TPC-9) • FR Toute plaque sur meuble ouvert - Plaque cm 39x73 (inclus 1 Élément de jonction top mod.TPC-9) • ES Placa de cocción sobre mueble abierto - Placa cm 39x73 (incluida 1 Chapa de cierre para top mod.TPC-9)  
**cm. 40x 90x 90h**



⚡ 7 kW  
6.020 kcal/h

**1.983,00**  
75 / 0,46

**TP-98G**  
09290850

**TUTTA PIASTRA GAS SU MOBILE A GIORNO PIASTRA CM 79X73 (INCLUSA 1 TESTATA CHIUSURA PIANO MOD.TPC-9)**

EN Solid top on open unit - Plate 79x73 cm (included 1 Head end filler strip mod.TPC-9) • DE Kochplatte auf offenem Unterbau - Platte 79x73 cm (inbegriffen 1 Abschluss-Element mod.TPC-9) • FR Toute plaque sur meuble ouvert - Plaque cm 79x73 (inclus 1 Élément de jonction top mod.TPC-9) • ES Placa de cocción sobre mueble abierto - Placa cm 79x73 (incluida 1 Chapa de cierre para top mod.TPC-9)  
**cm. 80x 90x 90h**



⚡ 12 kW  
10.320 kcal/h

**2.909,00**  
144 / 0,89



Le immagini presentate non sono vincolanti. La ditta si riserva di apportare modifiche senza preavviso. • The pictures are purely representative. The manufacturer reserves the right to modify the technical data and models without previous notice. • Les images

LO

présentées ne nous engagent pas. La Société se réserve le droit d'apporter tout modification sans préavis. • Die dargestellten Abbildungen sind nicht verbindlich. Technische Änderungen vorbehalten. • Las imágenes presentadas no son vinculantes. El Fabricante se reserva el derecho de modificar sus productos sin previo aviso.

01/20

241

90

# TUTTAPIASTRA A GAS

MOD. \_\_\_\_\_  
COD. \_\_\_\_\_

DESCRIZIONE/DESCRIPTION/BEZEICHNUNG/DESCRIPTION/DESCRIPCIÓN  
DIMENSIONI/DIMENSIONS/ABMESSUNGEN/DIMENSIONS/DIMENSIONES

POTENZA/POWER/LEISTUNG/PUISSANCE/POTENCIA  
VOLTAGGIO/VOLTAGE/SPANNUNG/VOLTAGE/VOLTAJE

⚡ kW  
kcal/h

⚡ kW  
V~  
Hz

PREZZO/PRICE €  
PREIS/PRIX/PRECIO €  
KG / M<sup>3</sup>

**TP2-98G**  
09300850

**TUTTA PIASTRA + 2 FUOCHI SU MOBILE A GIORNO PIASTRA CM. 39X73 (INCLUSA 1 TESTATA CHIUSURA PIANO MOD.TPC-9)**  
**EN** Solid top + 2 burners on open unit Plate 39x73 (included 1 Head end filler strip mod.TPC-9) • **DE** Kochplatte + 2 Gaskochstellen auf offenem Unterbau Platte 39x73 (inbegriffen 1 Abschluss-Element mod. TPC-9) • **FR** Toute plaque + 2 brûleurs sur meuble ouvert Plaque cm. 39x73 (inclus 1 Élément de jonction top mod.TPC-9) • **ES** Placa de cocción + 2 fuegos sobre mueble abierto Placa cm. 39x73 (incluida 1 Chapa de cierre para top mod.TPC-9)  
**cm. 80x 90x 90h**



⚡ 24 kW  
20.640 kcal/h

**2.898,00**  
139 / 0,89

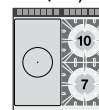

**TP2-912G**  
09291250

**TUTTA PIASTRA + 2 FUOCHI SU MOBILE A GIORNO PIASTRA CM. 79X73 (INCLUSA 1 TESTATA CHIUSURA PIANO MOD.TPC-9)**  
**EN** Solid top + 2 burners on open unit Plate 79x73 (included 1 Head end filler strip mod.TPC-9) • **DE** Kochplatte + 2 Gaskochstellen auf offenem Unterbau Platte 79x73 (inbegriffen 1 Abschluss-Element mod. TPC-9) • **FR** Toute plaque + 2 brûleurs sur meuble ouvert Plaque cm. 79x73 (inclus 1 Élément de jonction top mod.TPC-9) • **ES** Placa de cocción + 2 fuegos sobre mueble abierto Placa cm. 79x73 (incluida 1 Chapa de cierre para top mod.TPC-9)  
**cm. 120x 90x 90h**



⚡ 29 kW  
24.940 kcal/h

**4.204,00**  
166 / 1,32

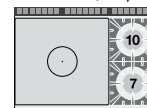

**TP4-912G**  
09301250

**TUTTA PIASTRA + 4 FUOCHI SU MOBILE A GIORNO PIASTRA CM. 39X73 (INCLUSA 1 TESTATA CHIUSURA PIANO MOD.TPC-9)**  
**EN** Solid top + 4 burners on open unit Plate 39x73 cm (included 1 Head end filler strip mod.TPC-9) • **DE** Kochplatte + 4 Gaskochstellen auf offenem Unterbau Platte 39x73 cm (inbegriffen 1 Abschluss-Element mod. TPC-9) • **FR** Toute plaque + 4 brûleurs sur meuble ouvert Plaque cm. 39x73 (inclus 1 Élément de jonction top mod.TPC-9) • **ES** Placa de cocción + 4 fuegos sobre mueble abierto Placa cm. 39x73 (incluida 1 Chapa de cierre para top mod.TPC-9)  
**cm. 120x 90x 90h**



⚡ 35 kW  
30.100 kcal/h

**4.026,00**  
160 / 1,32

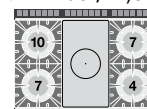

**TP-98ET**  
09120830

**TUTTA PIASTRA SU MOBILE A GIORNO PIASTRA CM. 70X68 - 4 ZONE (INCLUSA 1 TESTATA CHIUSURA PIANO MOD.TPA-9)**  
**EN** Solid top on open unit - Plate cm. 70x68 (included 1 Head end filler strip mod.TPA-9) • **DE** Kochplatten auf offenem Unterbau - Platte cm. 70x68 (inbegriffen 1 Abschluss-Element mod.TPA-9) • **FR** Toute plaque sur meuble ouvert - Plaque cm. 70x68 (inclus 1 Élément de jonction top mod.TPA-9) • **ES** Placa de cocción sobre mueble abierto - Placa cm. 70x68 (incluida 1 Chapa de cierre para top mod.TPA-9)  
**cm. 80x 90x 90h**



⚡ 13,6 kW  
400V~3N  
50/60 Hz

**3.517,00**  
114 / 0,89

**TPI-98ET**  
09120833

**TUTTOPIANO INDUZIONE TRIFASE - VETRO CM.75X77 (INCLUSA 1 TESTATA CHIUSURA PIANO MOD.TPA-9)**  
**EN** Three-phase induction Solid top - glass cm.75x77 (included 1 Head end filler strip mod.TPA-9) • **DE** Induktions-Kochplatte dreiphasig - Glas 75x77 cm (inbegriffen 1 Abschluss-Element mod.TPA-9) • **FR** Toute plaque à induction triphasé - Verre cm.75x77 (inclus 1 Élément de jonction top mod.TPA-9) • **ES** Placa de cocción inducción trifásica - Vidrio cm.75x77 (incluida 1 Chapa de cierre para top mod.TPA-9)  
**cm. 80x 90x 90h**



⚡ 28 kW  
400V~3  
50/60 Hz

**20.469,00**  
95 / 0,89



MOD. \_\_\_\_\_  
COD. \_\_\_\_\_

DESCRIZIONE/DESCRIPTION/BEZEICHNUNG/DESCRIPTION/DESCRIPCIÓN  
DIMENSIONI/DIMENSIONS/ABMESSUNGEN/DIMENSIONS/DIMENSIONES

POTENZA/POWER/LEISTUNG/PUISSANCE/POTENCIA  
VOLTAGGIO/VOLTAGE/SPANNUNG/VOLTAGE/VOLTAJE

⚡ kW kcal/h ⚡ kW V~ Hz  
PREZZO/PRICE € PREIS/PRIX/PRECIO € KG / M<sup>3</sup>

**TPI-98ETD**  
09120838

**TUTTOPIANO INDUZIONE TRIFASE - VETRO CM.75X77 - COMANDI DIGITALI (INCLUSA 1 TESTATA CHIUSURA PIANO MOD.TPA-9)**

**EN** Three-phase induction Solid top - glass cm.75x77 - digital controls (included 1 Head end filler strip mod.TPA-9) • **DE** Induktions-Kochplatte dreiphasig - Glas 75x77 cm - digitale Steuerungen (inbegriffen 1 Abschluss-Element mod.TPA-9) • **FR** Toute plaque à induction triphasé - Verre cm.75x77 - commandes numériques (inclus 1 Élément de jonction top mod.TPA-9) • **ES** Placa de cocción inducción trifásica - Vidrio cm.75x77 - controles digitales (incluida 1 Chapa de cierre para top mod.TPA-9)  
**cm. 80x 90x 90h**



⚡ 28 kW **21.463,00**  
400V~3 95 / 0,89  
50/60 Hz

**TPF-98ET**  
09670830

**TUTTA PIASTRA SU FORNO ELETTRICO STATICO CM. 67X73X34H, TEMP: 50÷300°C, CON 1 GRIGLIA CM.65X71 GN2/1 - PIASTRA CM. 70X68 4 ZONE (INCLUSA 1 TESTATA CHIUSURA PIANO MOD.TPA-9)**

**EN** Solid top on traditional electric cm. 67x73x34h, temp: 50÷300°C, with 1 grid cm.65x71 GN2/1 - Plate cm. 70x68 4 zones (included 1 Head end filler strip mod.TPA-9) • **DE** Kochplatten - Statischer Elektro-Backofen cm. 67x73x34h, temp: 50÷300°C, mit 1 Rost cm.65x71 GN2/1 - Platte cm. 70x68 4 zonen (inbegriffen 1 Abschluss-Element mod.TPA-9) • **FR** Toute plaque sur Four électrique statique cm. 67x73x34h, temp: 50÷300°C, avec 1 grille cm.65x71 GN2/1 - Plaque cm. 70x68 4 zones (inclus 1 Élément de jonction top mod.TPA-9) • **ES** Placa de cocción sobre Horno eléctrico estático cm. 67x73x34h, temp: 50÷300°C, con 1 parilla cm.65x71 GN2/1 - Placa cm. 70x68 4 zonas (incluida 1 Chapa de cierre para top mod.TPA-9)  
**cm. 80x 90x 90h**



⚡ 20,3 kW **4.505,00**  
400V~3N 180 / 0,89  
50/60 Hz

**TPFV-98ET**  
09670835

**TUTTA PIASTRA SU FORNO ELETTRICO VENTILATO CM. 55X36X34H, TEMP: 50÷300°C, CON 1 GRIGLIA CM.53X32,5 GN1/1 - PIASTRA CM. 70X68 4 ZONE (INCLUSA 1 TESTATA CHIUSURA PIANO MOD. TPA-9)**

**EN** Solid top on electric fan oven cm. 55x36x34h, temp: 50÷300°C, with 1 grid cm.53x32,5 GN1/1 - Plate cm. 70x68 4 zones (included 1 Head end filler strip mod.TPA-9) • **DE** Kochplatten - Elektro-Heißluftofen cm. 55x36x34h, temp: 50÷300°C, mit 1 Rost cm.53x32,5 GN1/1 - Platte cm. 70x68 4 Zonen (inbegriffen 1 Abschluss-Element mod.TPA-9) • **FR** Toute plaque sur Four à chaleur tournante électrique cm. 55x36x34h, temp: 50÷300°C, avec 1 grille cm.53x32,5 GN1/1 - Plaque cm. 70x68 4 zones (inclus 1 Élément de jonction top mod.TPA-9) • **ES** Placa de cocción sobre Horno eléctrico ventilado cm. 55x36x34h, temp: 50÷300°C, con 1 parilla cm.53x32,5 GN1/1 - Placa cm. 70x68 4 zonas (incluida 1 Chapa de cierre para top mod.TPA-9)  
**cm. 80x 90x 90h**

⚡ 18,92 kW **4.857,00**  
400V~3N 180 / 0,89  
50/60 Hz



# TUTTAPIASTRA A GAS CON FORNO

MOD. \_\_\_\_\_  
COD. \_\_\_\_\_

DESCRIZIONE/DESCRIPTION/BEZEICHNUNG/DESCRIPTION/DESCRIPCIÓN  
DIMENSIONI/DIMENSIONS/ABMESSUNGEN/DIMENSIONS/DIMENSIONES

POTENZA/POWER/LEISTUNG/PUISSANCE/POTENCIA  
VOLTAGGIO/VOLTAGE/SPANNUNG/VOLTAGE/VOLTAJE

⚡ kW  
kcal/h

⚡ kW  
V~  
Hz

PREZZO/PRICE €  
PREIS/PRIX/PRECIO €  
KG / M<sup>3</sup>

**TPF-98G**  
09700850

**TUTTA PIASTRA SU FORNO GAS STATICO**  
**CM. 67X73X34H, TEMP: 150÷300°C, CON**  
**1 GRIGLIA CM.65X71 GN2/1 - PIASTRA CM**  
**79X73 (INCLUSA 1 TESTATA CHIUSURA PIANO**  
**MOD.TPC-9)**

**EN** Solid top on Traditional gas-oven cm. 67x73x34h, temp: 150÷300°C, with 1 grid cm.65x71 GN2/1 - Plate cm. 79x73 (included 1 Head end filler strip mod. TPC-9) • **DE** Kochplatten - Statischer Gas-Backofen cm. 67x73x34h, temp: 150÷300°C, mit 1 Rost cm.65x71 GN2/1 - Platte cm. 79x73 (inbegriffen 1 Abschluss-Element mod.TPC-9) • **FR** Toute plaque sur Four à gaz statique cm. 67x73x34h, temp: 150÷300°C, avec 1 grille cm.65x71 GN2/1 - Plaque cm. 79x73 (inclus 1 Élément de jonction top mod.TPC-9) • **ES** Placa de cocción sobre Horno a gas estático cm. 67x73x34h, temp: 150÷300°C, con 1 parilla cm.65x71 GN2/1 - Placa cm. 79x73 (incluida 1 Chapa de cierre para top mod.TPC-9)

**cm. 80x 90x 90h**



⚡ 20,5 kW  
17.630 kcal/h

**4.208,00**  
194 / 0,89

**TPF-98GE**  
09710860

**TUTTA PIASTRA SU FORNO ELETTRICO STATICO**  
**CM. 67X73X34H, TEMP: 50÷300°C, CON 1**  
**GRIGLIA CM.65X71 GN2/1 - PIASTRA CM.**  
**79X73 (INCLUSA 1 TESTATA CHIUSURA PIANO**  
**MOD.TPC-9)**

**EN** Solid top on traditional electric oven cm. 67x73x34h, temp: 50÷300°C, with 1 grid cm.65x71 GN2/1 - Plate cm. 79x73 (included 1 Head end filler strip mod.TPC-9) • **DE** Kochplatten - Statischer Elektro-Backofen cm. 67x73x34h, temp: 50÷300°C, mit 1 Rost cm.65x71 GN2/1 - Platte cm. 79x73 (inbegriffen 1 Abschluss-Element mod.TPC-9) • **FR** Toute plaque sur Four électrique statique cm. 67x73x34h, temp: 50÷300°C, avec 1 grille cm.65x71 GN2/1 - Plaque cm. 79x73 (inclus 1 Élément de jonction top mod.TPC-9) • **ES** Placa de cocción sobre Horno eléctrico estático cm. 67x73x34h, temp: 50÷300°C, con 1 parilla cm.65x71 GN2/1 - Placa cm. 79x73 (incluida 1 Chapa de cierre para top mod.TPC-9)

**cm. 80x 90x 90h**



⚡ 12 kW  
10.320 kcal/h

**4.294,00**  
196 / 0,89

⚡ 6,7 kW  
400V~3N  
50/60 Hz

**TPFV-98GE**  
09710865

**TUTTA PIASTRA SU FORNO ELETTRICO**  
**VENTILATO CM. 55X36X34H, TEMP:**  
**50÷300°C, CON 1 GRIGLIA CM.53X32,5**  
**GN1/1 - PIASTRA CM. 79X73 (INCLUSA 1**  
**TESTATA CHIUSURA PIANO MOD.TPC-9)**

**EN** Solid top on electric fan oven cm. 55x36x34h, temp: 50÷300°C, with 1 grid cm.53x32,5 GN1/1 - Plate cm. 79x73 (included 1 Head end filler strip mod.TPC-9) • **DE** Kochplatten - Elektro-Heißluftofen cm. 55x36x34h, temp: 50÷300°C, mit 1 Rost cm.53x32,5 GN1/1 - Platte cm. 79x73 (inbegriffen 1 Abschluss-Element mod. TPC-9) • **FR** Toute plaque sur Four à chaleur tournante électrique cm. 55x36x34h, temp: 50÷300°C, avec 1 grille cm.53x32,5 GN1/1 - Plaque cm. 79x73 (inclus 1 Élément de jonction top mod.TPC-9) • **ES** Placa de cocción sobre Horno eléctrico ventilado cm. 55x36x34h, temp: 50÷300°C, con 1 parilla cm.53x32,5 GN1/1 - Placa cm. 79x73 (incluida 1 Chapa de cierre para top mod.TPC-9)

**cm. 80x 90x 90h**

⚡ 12 kW  
10.320 kcal/h

**4.646,00**  
196 / 0,89

⚡ 5,32 kW  
400V~3N  
230V~3  
50/60 Hz

# TUTTAPIASTRA A GAS CON FORNO

MOD. \_\_\_\_\_  
COD. \_\_\_\_\_

DESCRIZIONE/DESCRIPTION/BEZEICHNUNG/DESCRIPTION/DESCRIPCIÓN  
DIMENSIONI/DIMENSIONS/ABMESSUNGEN/DIMENSIONS/DIMENSIONES

POTENZA/POWER/LEISTUNG/PUISSANCE/POTENCIA  
VOLTAGGIO/VOLTAGE/SPANNUNG/VOLTAGE/VOLTAJE

⚡ kW  
kcal/h

PREZZO/PRICE €  
PREIS/PRIX/PRECIO €  
KG / M<sup>3</sup>

**TPF2-98G**  
09720850

**TUTTA PIASTRA + 2 FUOCHI SU FORNO GAS STATICO CM. 67X73X34H, TEMP: 150÷300°C, CON 1 GRIGLIA CM.65X71 GN2/1 - PIASTRA CM 39X73 (INCLUSA 1 TESTATA CHIUSURA PIANO MOD.TPC-9)**

**EN** Solid top + 2 burners Traditional gas-oven cm. 67x73x34h, temp: 150÷300°C, with 1 grid cm.65x71 GN2/1 - Plate 39x73 (included 1 Head end filler strip mod.TPC-9) • **DE** Kochplatte + 2 Gaskochstellen auf Statischer Gas-Backofen cm. 67x73x34h, temp: 150÷300°C, mit 1 Rost cm.65x71 GN2/1 - Platte 39x73 cm (inbegriffen 1 Abschluss-Element mod.TPC-9) • **FR** Toute plaque + 2 brûleurs sur Four à gaz statique cm. 67x73x34h, temp: 150÷300°C, avec 1 grille cm.65x71 GN2/1 - Plaque cm. 39x73 (inclus 1 Élément de jonction top mod.TPC-9) • **ES** Placa de cocción + 2 fuegos sobre Horno a gas estático cm. 67x73x34h, temp: 150÷300°C, con 1 parilla cm.65x71 GN2/1 - Placa cm 39x73 (incluida 1 Chapa de cierre para top mod.TPC-9)  
**cm. 80x 90x 90h**



⚡ 32,5 kW  
27.950 kcal/h

**4.236,00**  
181 / 0,89

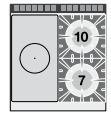

**TPF2-98GE**  
09730860

**TUTTA PIASTRA + 2 FUOCHI SU FORNO ELETTRICO STATICO CM. 67X73X34H, TEMP: 50÷300°C, CON 1 GRIGLIA CM.65X71 GN2/1 - PIASTRA CM 39X73 (INCLUSA 1 TESTATA CHIUSURA PIANO MOD.TPC-9)**

**EN** Solid top + 2 burners traditional electric oven cm. 67x73x34h, temp: 50÷300°C, with 1 grid cm.65x71 GN2/1 - Plate 39x73 (included 1 Head end filler strip mod.TPC-9) • **DE** Kochplatte + 2 Gaskochstellen auf Statischer Elektro-Backofen cm. 67x73x34h, temp: 50÷300°C, mit 1 Rost cm.65x71 GN2/1 - Platte 39x73 (inbegriffen 1 Abschluss-Element mod.TPC-9) • **FR** Toute plaque + 2 brûleurs sur Four électrique statique cm. 67x73x34h, temp: 50÷300°C, avec 1 grille cm.65x71 GN2/1 - Plaque cm. 39x73 (inclus 1 Élément de jonction top mod.TPC-9) • **ES** Placa de cocción + 2 fuegos sobre Horno eléctrico estático GN 2/1 cm. 68x73x34h, temp: 50÷300°C, Placa cm 39x73 (incluida 1 Chapa de cierre para top mod.TPC-9)  
**cm. 80x 90x 90h**



⚡ 24 kW  
20.640 kcal/h

**4.322,00**  
191 / 0,89

⚡ 6,7 kW  
400V~3N  
50/60 Hz

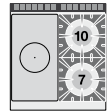

**TPFV2-98GE**  
09730865

**TUTTA PIASTRA + 2 FUOCHI SU FORNO ELETTRICO VENTILATO CM. 55X36X34H, TEMP: 50÷300°C, CON 1 GRIGLIA CM.53X32,5 GN1/1 - PIASTRA CM 39X73 (INCLUSA 1 TESTATA CHIUSURA PIANO MOD. TPC-9)**

**EN** Solid top + 2 burners electric fan oven cm. 55x36x34h, temp: 50÷300°C, with 1 grid cm.53x32,5 GN1/1 - Plate 39x73 (included 1 Head end filler strip mod.TPC-9) • **DE** Kochplatte + 2 Gaskochstellen - Elektro-Heißluftofen cm. 55x36x34h, temp: 50÷300°C, mit 1 Rost cm.53x32,5 GN1/1 - Platte 39x73 (inbegriffen 1 Abschluss-Element mod.TPC-9) • **FR** Toute plaque + 2 brûleurs sur Four à chaleur tournante électrique cm. 55x36x34h, temp: 50÷300°C, avec 1 grille cm.53x32,5 GN1/1 - Plaque cm. 39x73 (inclus 1 Élément de jonction top mod.TPC-9) • **ES** Placa de cocción + 2 fuegos sobre Horno eléctrico ventilado cm. 55x36x34h, temp: 50÷300°C, con 1 parilla cm.53x32,5 GN1/1 - Placa cm 39x73 (incluida 1 Chapa de cierre para top mod.TPC-9)  
**cm. 80x 90x 90h**

⚡ 24 kW  
20.640 kcal/h

**4.672,00**  
191 / 0,89

⚡ 5,32 kW  
400V~3N  
230V~3  
50/60 Hz

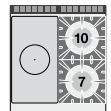

Le immagini presentate non sono vincolanti. La ditta si riserva di apportare modifiche senza preavviso. • The pictures are purely representative. The manufacturer reserves the right to modify the technical data and models without previous notice. • Les images

LO

présentées ne nous engagent pas. La Société se réserve le droit d'apporter tout modification sans préavis. • Die dargestellten Abbildungen sind nicht verbindlich. Technische Änderungen vorbehalten. • Las imágenes presentadas no son vinculantes. El Fabricante se reserva el derecho de modificar sus productos sin previo aviso.

01/20

**245**

# TUTTAPIASTRA A GAS CON FORNO

MOD. \_\_\_\_\_  
COD. \_\_\_\_\_

DESCRIZIONE / DESCRIPTION / BEZEICHNUNG / DESCRIPTION / DESCRIPCIÓN  
DIMENSIONI / DIMENSIONS / ABMESSUNGEN / DIMENSIONS / DIMENSIONES

POTENZA / POWER / LEISTUNG / PUISSANCE / POTENCIA  
VOLTAGGIO / VOLTAGE / SPANNUNG / VOLTAGE / VOLTAJE

⚡ kW \_\_\_\_\_  
kcal/h \_\_\_\_\_  
⚡ kw \_\_\_\_\_  
V~ \_\_\_\_\_  
Hz \_\_\_\_\_

PREZZO / PRICE € \_\_\_\_\_  
PREIS / PRIX / PRECIO € \_\_\_\_\_  
KG / M<sup>3</sup> \_\_\_\_\_

**TPF2-912GV TUTTA PIASTRA + 2 FUOCHI SU FORNO GAS STATICO CM. 67X73X34H, TEMP: 150÷300°C, CON 1 GRIGLIA CM.65X71 GN2/1 - PIASTRA CM 79X73 - VANO NEUTRO CON PORTA (INCLUSA 1 TESTATA CHIUSURA PIANO MOD. TPC-9)**

09701251

**EN** Solid top + 2 burners Traditional gas-oven cm. 67x73x34h, temp: 150÷300°C, with 1 grid cm.65x71 GN2/1 - Plate 79x73 cm - Neutral cabinet with door (included 1 Head end filler strip mod.TPC-9) • **DE** Kochplatte + 2 Gaskochstellen auf Statischer Gas-Backofen cm. 67x73x34h, temp: 150÷300°C, mit 1 Rost cm.65x71 GN2/1 - Platte 79x73 cm - Neutrales Schrankelement mit Tür (inbegriffen 1 Abschluss-Element mod.TPC-9) • **FR** Toute plaque + 2 brûleurs sur Four à gaz statique cm. 67x73x34h, temp: 150÷300°C, avec 1 grille cm.65x71 GN2/1 - Plaque cm. 79x73 - Element neutre avec porte (inclus 1 Élément de jonction top mod.TPC-9) • **ES** Placa de cocción + 2 fuegos sobre Horno a gas estático cm. 67x73x34h, temp: 150÷300°C, con 1 parilla cm.65x71 GN2/1 - Placa cm 79x73 - Armario neutro con puerta (incluida 1 Chapa de cierre para top mod.TPC-9)

**cm. 120x 90x 90h**



⚡ 37,5 kW \_\_\_\_\_ **5.663,00**  
32.250 kcal/h \_\_\_\_\_ 254 / 1,32

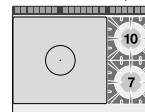

**TPF2-912GEV TUTTA PIASTRA + 2 FUOCHI SU FORNO ELETTRICO STATICO CM. 67X73X34H, TEMP: 50÷300°C, CON 1 GRIGLIA CM.65X71 GN2/1 - PIASTRA CM 79X73 - VANO NEUTRO CON PORTA (INCLUSA 1 TESTATA CHIUSURA PIANO MOD. TPC-9)**

09711261

**EN** Solid top + 2 burners traditional electric oven cm. 67x73x34h, temp: 50÷300°C, with 1 grid cm.65x71 GN2/1 - Plate 79x73 cm - Neutral cabinet with door (included 1 Head end filler strip mod.TPC-9) • **DE** Kochplatte + 2 Gaskochstellen auf Statischer Elektro-Backofen cm. 67x73x34h, temp: 50÷300°C, mit 1 Rost cm.65x71 GN2/1 - Platte 79x73 cm - Neutrales Schrankelement mit Tür (inbegriffen 1 Abschluss-Element mod.TPC-9) • **FR** Toute plaque + 2 brûleurs sur Four électrique statique cm. 67x73x34h, temp: 50÷300°C, avec 1 grille cm.65x71 GN2/1 - Plaque cm. 79x73 - Element neutre avec porte (inclus 1 Élément de jonction top mod.TPC-9) • **ES** Placa de cocción + 2 fuegos sobre Horno eléctrico estático cm. 67x73x34h, temp: 50÷300°C, con 1 parilla cm.65x71 GN2/1 - Placa cm 79x73 - Armario neutro con puerta (incluida 1 Chapa de cierre para top mod.TPC-9)

**cm. 120x 90x 90h**



⚡ 29 kW \_\_\_\_\_ **5.749,00**  
24.940 kcal/h \_\_\_\_\_ 250 / 1,32

⚡ 6,7 kW \_\_\_\_\_  
400V~3N \_\_\_\_\_  
50/60 Hz \_\_\_\_\_

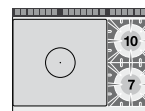

**TPFV2-912GEV TUTTA PIASTRA + 2 FUOCHI SU FORNO ELETTRICO VENTILATO CM. 55X36X34H, TEMP: 50÷300°C, CON 1 GRIGLIA CM.53X32,5 GN1/1 - PIASTRA CM 79X73 - VANO NEUTRO CON PORTA (INCLUSA 1 TESTATA CHIUSURA PIANO MOD. TPC-9)**

09711266

**EN** Solid top + 2 burners electric fan oven cm. 55x36x34h, temp: 50÷300°C, with 1 grid cm.53x32,5 GN1/1 - Plate 79x73 cm - Neutral cabinet with door (included 1 Head end filler strip mod.TPC-9) • **DE** Kochplatte + 2 Gaskochstellen - Elektro-Heißluftofen cm. 55x36x34h, temp: 50÷300°C, mit 1 Rost cm.53x32,5 GN1/1 - Platte 79x73 cm - Neutrales Schrankelement mit Tür (inbegriffen 1 Abschluss-Element mod.TPC-9) • **FR** Toute plaque + 2 brûleurs sur Four à chaleur tournante électrique cm. 55x36x34h, temp: 50÷300°C, avec 1 grille cm.53x32,5 GN1/1 - Plaque cm. 79x73 - Element neutre avec porte (inclus 1 Élément de jonction top mod.TPC-9) • **ES** Placa de cocción + 2 fuegos sobre Horno eléctrico ventilado cm. 55x36x34h, temp: 50÷300°C, con 1 parilla cm.53x32,5 GN1/1 - Placa cm 79x73 - Armario neutro con puerta (incluida 1 Chapa de cierre para top mod.TPC-9)

**cm. 120x 90x 90h**

⚡ 29 kW \_\_\_\_\_ **6.101,00**  
24.940 kcal/h \_\_\_\_\_ 250 / 1,32

⚡ 5,32 kW \_\_\_\_\_  
400V~3N \_\_\_\_\_  
230V~3 \_\_\_\_\_  
50/60 Hz \_\_\_\_\_

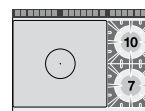

# TUTTAPIASTRA A GAS CON FORNO

MOD. \_\_\_\_\_  
COD. \_\_\_\_\_

DESCRIZIONE/DESCRIPTION/BEZEICHNUNG/DESCRIPTION/DESCRIPCIÓN  
DIMENSIONI/DIMENSIONS/ABMESSUNGEN/DIMENSIONS/DIMENSIONES

POTENZA/POWER/LEISTUNG/PUISSANCE/POTENCIA  
VOLTAGGIO/VOLTAGE/SPANNUNG/VOLTAGE/VOLTAJE

⚡ kW  
kcal/h

PREZZO/PRICE €  
PREIS/PRIX/PRECIO €  
KG / M<sup>3</sup>

**TPF2-912G**  
09701250

**TUTTA PIASTRA + 2 FUOCHI SU FORNO GAS STATICO CM. 107X73X34H, TEMP: 150÷300°C, CON 1 GRIGLIA CM.105X71 - PIASTRA CM 79X73 (INCLUSA 1 TESTATA CHIUSURA PIANO MOD.TPC-9)**  
**EN** Solid top + 2 burners Traditional gas-oven cm. 107x73x34h, temp: 150÷300°C, with 1 grid cm.105x71 - Plate 79x73 (included 1 Head end filler strip mod.TPC-9) • **DE** Kochplatte + 2 Gaskochstellen auf Statischer Gas-Backofen cm. 107x73x34h, temp: 150÷300°C, mit 1 Rost cm.105x71 - Platte 79x73 (inbegriffen 1 Abschluss-Element mod.TPC-9) • **FR** Toute plaque + 2 brûleurs sur Four à gaz statique cm. 107x73x34h, temp: 150÷300°C, avec 1 grille cm.105x71 - Plaque cm. 79x73 (inclus 1 Elément de jonction top mod.TPC-9) • **ES** Placa de cocción + 2 fuegos sobre Horno a gas estático cm. 107x73x34h, temp: 150÷300°C, con 1 parilla cm.105x71 - Placa cm 79x73 (incluida 1 Chapa de cierre para top mod.TPC-9)  
**cm. 120x 90x 90h**



⚡ 42 kW  
36.080 kcal/h

**5.938,00**  
264 / 1,32

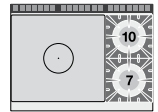

**TPF2-912GE**  
09711260

**TUTTA PIASTRA + 2 FUOCHI SU FORNO ELETTRICO STATICO CM. 107X73X34H, TEMP: 50÷300°C, CON 1 GRIGLIA CM.105X71 - PIASTRA CM 79X73 (INCLUSA 1 TESTATA CHIUSURA PIANO MOD.TPC-9)**  
**EN** Solid top + 2 burners traditional electric oven cm. 107x73x34h, temp: 50÷300°C, with 1 grid cm.105x71 - Plate 79x73 (included 1 Head end filler strip mod.TPC-9) • **DE** Kochplatte + 2 Gaskochstellen auf Statischer Elektro-Backofen cm. 107x73x34h, temp: 50÷300°C, mit 1 Rost cm.105x71 - Platte 79x73 (inbegriffen 1 Abschluss-Element mod.TPC-9) • **FR** Toute plaque + 2 brûleurs sur Four électrique statique cm. 107x73x34h, temp: 50÷300°C, avec 1 grille cm.105x71 - Plaque cm. 79x73 (inclus 1 Elément de jonction top mod.TPC-9) • **ES** Placa de cocción + 2 fuegos sobre Horno eléctrico estático cm. 107x73x34h, temp: 50÷300°C, con 1 parilla cm.105x71 - Placa cm 79x73 (incluida 1 Chapa de cierre para top mod.TPC-9)  
**cm. 120x 90x 90h**



⚡ 29 kW  
24.940 kcal/h

**6.051,00**  
260 / 1,32

⚡ 9,2 kW  
400V~3N  
50/60 Hz

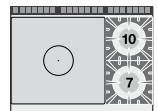

**TPF4-912GV**  
09721251

**TUTTA PIASTRA + 4 FUOCHI SU FORNO GAS STATICO CM. 67X73X34H, TEMP: 150÷300°C, CON 1 GRIGLIA CM.65X71 GN2/1 - PIASTRA CM 39X73 - VANO NEUTRO CON PORTA (INCLUSA 1 TESTATA CHIUSURA PIANO MOD. TPC-9)**  
**EN** Solid top + 4 burners Traditional gas-oven cm. 67x73x34h, temp: 150÷300°C, with 1 grid cm.65x71 GN2/1 - Plate 39x73 cm - Neutral cabinet with door (included 1 Head end filler strip mod.TPC-9) • **DE** Kochplatte + 4 Gaskochstellen auf Statischer Gas-Backofen cm. 67x73x34h, temp: 150÷300°C, mit 1 Rost cm.65x71 GN2/1 - Platte 39x73 cm - Neutrales Schrankelement mit Tür (inbegriffen 1 Abschluss-Element mod.TPC-9) • **FR** Toute plaque + 4 brûleurs sur Four à gaz statique cm. 67x73x34h, temp: 150÷300°C, avec 1 grille cm.65x71 GN2/1 - Plaque cm. 39x73 - Element neutre avec porte (inclus 1 Elément de jonction top mod.TPC-9) • **ES** Placa de cocción + 4 fuegos sobre Horno a gas estático cm. 67x73x34h, temp: 150÷300°C, con 1 parilla cm.65x71 GN2/1 - Placa cm 39x73 - Armario neutro con puerta (incluida 1 Chapa de cierre para top mod.TPC-9)  
**cm. 120x 90x 90h**



⚡ 43,5 kW  
37.410 kcal/h

**5.742,00**  
249 / 1,32

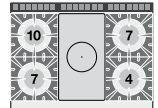

Le immagini presentate non sono vincolanti. La ditta si riserva di apportare modifiche senza preavviso. • The pictures are purely representative. The manufacturer reserves the right to modify the technical data and models without previous notice. • Les images

LO

présentées ne nous engagent pas. La Société se réserve le droit d'apporter tout modification sans préavis. • Die dargestellten Abbildungen sind nicht verbindlich. Technische Änderungen vorbehalten. • Las imágenes presentadas no son vinculantes. El Fabricante se reserva el derecho de modificar sus productos sin previo aviso.

01/20

247

90



# TUTTAPIASTRA A GAS CON FORNO ELETTRICO

MOD. \_\_\_\_\_  
COD. \_\_\_\_\_

DESCRIZIONE/DESCRIPTION/BEZEICHNUNG/DESCRIPTION/DESCRIPCIÓN  
DIMENSIONI/DIMENSIONS/ABMESSUNGEN/DIMENSIONS/DIMENSIONES

POTENZA/POWER/LEISTUNG/PUISSANCE/POTENCIA  
VOLTAGGIO/VOLTAGE/SPANNUNG/VOLTAGE/VOLTAJE

⚡ kW  
kcal/h

⚡ kW  
V~  
Hz

PREZZO/PRICE €  
PREIS/PRIX/PRECIO €  
KG / M<sup>3</sup>

**TPF4-912GEV TUTTA PIASTRA + 4 FUOCHI SU FORNO  
ELETTRICO STATICO CM. 67X73X34H, TEMP:  
50÷300°C, CON 1 GRIGLIA CM.65X71 GN2/1  
- PIASTRA CM 39X73 - VANO NEUTRO CON  
PORTA (INCLUSA 1 TESTATA CHIUSURA PIANO  
MOD.TPC-9)**

**EN** Solid top + 4 burners traditional electric oven cm. 67x73x34h, temp: 50÷300°C, with 1 grid cm.65x71 GN2/1 - Plate 39x73 cm - Neutral cabinet with door (included 1 Head end filler strip mod.TPC-9) • **DE** Kochplatte + 4 Gaskochstellen auf Statischer Elektro-Backofen cm. 67x73x34h, temp: 50÷300°C, mit 1 Rost cm.65x71 GN2/1 - Platte 39x73 cm - Neutrales Schrankelement mit Tür (inbegriffen 1 Abschluss-Element mod.TPC-9) • **FR** Toute plaque + 4 brûleurs sur Four électrique statique cm. 67x73x34h, temp: 50÷300°C, avec 1 grille cm.65x71 GN2/1 - Plaque cm. 39x73 - Element neutre avec porte (inclus 1 Élément de jonction top mod.TPC-9) • **ES** Placa de cocción + 4 fuegos sobre Horno eléctrico estático cm. 67x73x34h, temp: 50÷300°C, con 1 parilla cm.65x71 GN2/1 - Placa cm 39x73 - Armario neutro con puerta (incluida 1 Chapa de cierre para top mod.TPC-9)  
**cm. 120x 90x 90h**



⚡ 35 kW  
30.100 kcal/h

**5.827,00**  
245 / 1,32

⚡ 6,7 kW  
400V~3N  
50/60 Hz

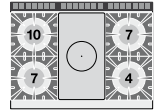

**TPFV4-912GEV TUTTA PIASTRA + 4 FUOCHI SU FORNO  
ELETTRICO VENTILATO CM. 55X36X34H,  
TEMP: 50÷300°C, CON 1 GRIGLIA  
CM.53X32,5 GN1/1 - PIASTRA CM 39X73  
- VANO NEUTRO CON PORTA (INCLUSA 1  
TESTATA CHIUSURA PIANO MOD.TPC-9)**

**EN** Solid top + 4 burners electric fan oven cm. 55x36x34h, temp: 50÷300°C, with 1 grid cm.53x32,5 GN1/1 - Plate 39x73 cm - Neutral cabinet with door (included 1 Head end filler strip mod.TPC-9) • **DE** Kochplatte + 4 Gaskochstellen - Elektro-Heißluftofen cm. 55x36x34h, temp: 50÷300°C, mit 1 Rost cm.53x32,5 GN1/1 - Platte 39x73 cm - Neutrales Schrankelement mit Tür (inbegriffen 1 Abschluss-Element mod.TPC-9) • **FR** Toute plaque + 4 brûleurs sur Four à chaleur tournante électrique cm. 55x36x34h, temp: 50÷300°C, avec 1 grille cm.53x32,5 GN1/1 - Plaque cm. 39x73 - Element neutre avec porte (inclus 1 Élément de jonction top mod.TPC-9) • **ES** Placa de cocción + 4 fuegos sobre Horno eléctrico ventilado cm. 55x36x34h, temp: 50÷300°C, con 1 parilla cm.53x32,5 GN1/1 - Placa cm 39x73 - Armario neutro con puerta (incluida 1 Chapa de cierre para top mod.TPC-9)  
**cm. 120x 90x 90h**

⚡ 35 kW  
30.100 kcal/h

**6.178,00**  
245 / 1,32

⚡ 5,32 kW  
400V~3N  
230V~3  
50/60 Hz

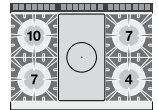

**TPF4-912G TUTTA PIASTRA + 4 FUOCHI SU FORNO  
GAS STATICO CM. 107X73X34H, TEMP:  
150÷300°C, CON 1 GRIGLIA CM.105X71 -  
PIASTRA CM 39X73 (INCLUSA 1 TESTATA  
CHIUSURA PIANO MOD.TPC-9)**

**EN** Solid top + 4 burners Traditional gas-oven cm. 107x73x34h, temp: 150÷300°C, with 1 grid cm.105x71 - Plate 39x73 cm (included 1 Head end filler strip mod.TPC-9) • **DE** Kochplatte + 4 Gaskochstellen auf Statischer Gas-Backofen cm. 107x73x34h, temp: 150÷300°C, mit 1 Rost cm.105x71 - Platte 39x73 cm (inbegriffen 1 Abschluss-Element mod.TPC-9) • **FR** Toute plaque + 4 brûleurs sur Four à gaz statique cm. 107x73x34h, temp: 150÷300°C, avec 1 grille cm.105x71 - Plaque cm. 39x73 (inclus 1 Élément de jonction top mod.TPC-9) • **ES** Placa de cocción + 4 fuegos sobre Horno a gas estático cm. 107x73x34h, temp: 150÷300°C, con 1 parilla cm.105x71 - Placa cm 39x73 (incluida 1 Chapa de cierre para top mod.TPC-9)  
**cm. 120x 90x 90h**



⚡ 48 kW  
41.280 kcal/h

**6.101,00**  
259 / 1,32

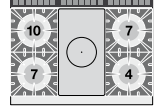



# TUTTAPIASTRA A GAS CON FORNO ELETTRICO

MOD. \_\_\_\_\_  
COD. \_\_\_\_\_

DESCRIZIONE/DESCRIPTION/BEZEICHNUNG/DESCRIPTION/DESCRIPCIÓN  
DIMENSIONI/DIMENSIONS/ABMESSUNGEN/DIMENSIONS/DIMENSIONES

POTENZA/POWER/LEISTUNG/PUISSANCE/POTENCIA  
VOLTAGGIO/VOLTAGE/SPANNUNG/VOLTAGE/VOLTAJE

⚡ kW \_\_\_\_\_  
kcal/h \_\_\_\_\_  
⚡ kW \_\_\_\_\_  
V~ \_\_\_\_\_  
Hz \_\_\_\_\_

PREZZO/PRICE € \_\_\_\_\_  
PREIS/PRIX/PRECIO € \_\_\_\_\_  
KG / M<sup>3</sup> \_\_\_\_\_

**TPF4-912GE TUTTA PIASTRA + 4 FUOCHI SU FORNO  
ELETTRICO STATICO CM. 107X73X34H, TEMP:  
50÷300°C, CON 1 GRIGLIA CM.105X71 -  
PIASTRA CM 39X73 (INCLUSA 1 TESTATA  
CHIUSURA PIANO MOD.TPC-9)**

09731260

**EN** Solid top + 4 burners traditional electric oven cm. 107x73x34h, temp: 50÷300°C, with 1 grid cm.105x71 - Plate 39x73 cm (included 1 Head end filler strip mod.TPC-9) • **DE** Kochplatte + 4 Gaskochstellen auf Statischer Elektro-Backofen cm. 107x73x34h, temp: 50÷300°C, mit 1 Rost cm.105x71 - Platte 39x73 cm (inbegriffen 1 Abschluss-Element mod.TPC-9) • **FR** Toute plaque + 4 brûleurs sur Four électrique statique cm. 107x73x34h, temp: 50÷300°C, avec 1 grille cm.105x71 - Plaque cm. 39x73 (inclus 1 Élément de jonction top mod.TPC-9) • **ES** Placa de cocción + 4 fuegos sobre Horno eléctrico estático cm. 107x73x34h, temp: 50÷300°C, con 1 parilla cm.105x71 - Placa cm 39x73 (incluida 1 Chapa de cierre para top mod.TPC-9)  
**cm. 120x 90x 90h**



⚡ 35 kW \_\_\_\_\_ **6.210,00**  
30.100 kcal/h \_\_\_\_\_ 255 / 1,32

⚡ 9,2 kW \_\_\_\_\_  
400V~3N \_\_\_\_\_  
50/60 Hz \_\_\_\_\_

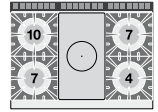

**BM-94EM BAGNOMARIA MONOFASE SU MOBILE A  
GIORNO VASCA PER GN 1/1 + GN 1/3 H.  
15 RUBINETTO CARICO ACQUA, SCARICO A  
PAVIMENTO (INCLUSA 1 TESTATA CHIUSURA  
PIANO MOD.TPA-9)**

09050410

**EN** Bain-marie singlephase on open cabinet - Bowl for GN 1/1 + GN 1/3 h.15 - Water loading tap floor draining (included 1 Head end filler strip mod.TPA-9) • **DE** Wasserbäder einphasig mit Offenem Unterbau - Becken GN 1/1 + GN 1/3 h.15 - Wasserlauf-Hahn, Ablauf am Boden (inbegriffen 1 Abschluss-Element mod.TPA-9) • **FR** Bain marie monophasé sur armoire ouvert Cuve GN 1/1 + GN 1/3 h.15 Robinet d'arrivée d'eau - Système de vidange au sol (inclus 1 Élément de jonction top mod.TPA-9) • **ES** Baño de maría monofásico sobre mueble abierto Cuba para GN 1/1 + GN 1/3 15h Grifo carga agua, descarga a pavimento (incluida 1 Chapa de cierre para top mod.TPA-9)  
**cm. 40x 90x 90h**



⚡ 2,85 kW \_\_\_\_\_ **1.824,00**  
230V~ \_\_\_\_\_ 52 / 0,46  
50/60 Hz \_\_\_\_\_

**BM-98ET BAGNOMARIA TRIFASE SU MOBILE A GIORNO  
- VASCA PER GN 2/1 + 2 X GN 1/3 15H  
RUBINETTO CARICO ACQUA + SCARICO A  
PAVIMENTO (INCLUSA 1 TESTATA CHIUSURA  
PIANO MOD.TPA-9)**

09050830

**EN** Bain-marie threephase on open cabinet - Bowl for GN 2/1 + 2 x GN 1/3 15h - Floor draining (included 1 Head end filler strip mod.TPA-9) • **DE** Wasserbäder dreiphasig mit offenem Unterbau - Becken GN 2/1 + 2 x GN 1/3 15h - Ablauf am Boden (inbegriffen 1 Abschluss-Element mod.TPA-9) • **FR** Bain marie triphase sur armoire ouvert - Cuve GN 2/1 + 2 x GN 1/3 15h - Système de vidange au sol (inclus 1 Élément de jonction top mod.TPA-9) • **ES** Baño de maría trifásico sobre mueble abierto Cuba para GN 2/1 + 2 x GN 1/3 h.15 - Descarga a pavimento (incluida 1 Chapa de cierre para top mod.TPA-9)  
**cm. 80x 90x 90h**



⚡ 5,7 kW \_\_\_\_\_ **2.463,00**  
400V~3N \_\_\_\_\_ 76 / 0,89  
230V~3 \_\_\_\_\_  
50/60 Hz \_\_\_\_\_

MOD. \_\_\_\_\_  
COD. \_\_\_\_\_

DESCRIZIONE/DESCRIPTION/BEZEICHNUNG/DESCRIPTION/DESCRIPCIÓN  
DIMENSIONI/DIMENSIONS/ABMESSUNGEN/DIMENSIONS/DIMENSIONES

POTENZA/POWER/LEISTUNG/PUISSANCE/POTENCIA  
VOLTAGGIO/VOLTAGE/SPANNUNG/VOLTAGE/VOLTAJE

⚡ kW \_\_\_\_\_  
kcal/h \_\_\_\_\_  
V~ \_\_\_\_\_  
Hz \_\_\_\_\_

PREZZO/PRICE € \_\_\_\_\_  
PREIS/PRIX/PRECIO € \_\_\_\_\_  
KG / M<sup>3</sup> \_\_\_\_\_

**BM-94G**  
09220450

**BAGNOMARIA GAS SU MOBILE A GIORNO  
VASCA PER GN 1/1 + GN 1/3 H.15  
RUBINETTO CARICO ACQUA, SCARICO A  
PAVIMENTO (INCLUSA 1 TESTATA CHIUSURA  
PIANO MOD.TPA-9)**

**EN** Gas bain-marie on open cabinet - Bowl for GN 1/1 + GN 1/3 h.15 - Water loading tap and floor draining (included 1 Head end filler strip mod.TPA-9) • **DE** Gas Wasserbad mit offenem Unterbau - Becken GN 1/1 + GN 1/3 h.15 - Wasserlauf-Hahn, Ablauf am Boden (inbegriffen 1 Abschluss-Element mod.TPA-9) • **FR** Bain-marie gaz sur armoire ouvert Cuve pour GN 1/1 + GN 1/3 h.15 Robinet d'arrivée d'eau, système de vidange au sol (inclus 1 Élément de jonction top mod.TPA-9) • **ES** Baño de maría gas sobre mueble abierto Cuba para GN 1/1 + GN 1/3 h.15 Grifo carga agua, descarga a pavimento (incluida 1 Chapa de cierre para top mod.TPA-9)

cm. 40x 90x 90h



⚡ 3,5 kW \_\_\_\_\_ **1.957,00**  
3.010 kcal/h \_\_\_\_\_ 56 / 0,46

**BM-98G**  
09220850

**BAGNOMARIA GAS SU MOBILE A GIORNO  
VASCA PER GN 2/1 + 2 X GN 1/3 H.15  
RUBINETTO CARICO ACQUA, SCARICO A  
PAVIMENTO (INCLUSA 1 TESTATA CHIUSURA  
PIANO MOD.TPA-9)**

**EN** Gas bain-marie on open cabinet - Bowl for GN 2/1 + 2 x GN 1/3 h.15 - Water loading tap and floor draining (included 1 Head end filler strip mod.TPA-9) • **DE** Gas Wasserbad mit offenem Unterbau - Becken GN 2/1 + 2 x GN 1/3 h.15 - Wasserlauf-Hahn, Ablauf am Boden (inbegriffen 1 Abschluss-Element mod.TPA-9) • **FR** Bain-marie gaz sur armoire ouvert Cuve pour GN 2/1 + 2 x GN 1/3 h.15 Robinet d'arrivée d'eau, système de vidange au sol (inclus 1 Élément de jonction top mod.TPA-9) • **ES** Baño de maría gas sobre mueble abierto Cuba para GN 2/1 + 2 x GN 1/3 h.15 Grifo carga agua, descarga a pavimento (incluida 1 Chapa de cierre para top mod.TPA-9)

cm. 80x 90x 90h



⚡ 6,5 kW \_\_\_\_\_ **2.831,00**  
5.590 kcal/h \_\_\_\_\_ 81 / 0,89

**BS-94EM**  
09040410

**CONTENITORE CALDO CON INFRAROSSO,  
MONOFASE SU MOBILE A GIORNO VASCA  
CM. 30,5X51X16,5H CON FALSO FONDO  
FORATO (INCLUSA 1 TESTATA CHIUSURA  
PIANO MOD.TPA-9)**

**EN** Fry dump singlephase with infra-red heater on open cabinet. Bowl cm. 30,5x51x16,5h with perforated double bottom (included 1 Head end filler strip mod.TPA-9) • **DE** Frittenwanne Einphasig mit Infrarot-strahler mit offenem Unterbau. Becke cm. 30,5x51x16,5h mit gelochtem Bodenrost (inbegriffen 1 Abschluss-Element mod.TPA-9) • **FR** Silo a frites monophasé avec infrarouge sur armoire ouvert. Cuve cm 30,5x51x16,5h avec double-fond perforé. (inclus 1 Élément de jonction top mod.TPA-9) • **ES** Contenedor caliente por infrarrojo, monofásico y sobre mueble abierto. Cuba cm. 30,5x51x16,5h con falso fondo agujereado (incluida 1 Chapa de cierre para top mod.TPA-9)

cm. 40x 90x 90h



⚡ 1,47 kW \_\_\_\_\_ **1.985,00**  
230V~ \_\_\_\_\_ 60 / 0,46  
50/60 Hz \_\_\_\_\_

# CUOCIPASTA ELETTRICI

MOD. \_\_\_\_\_  
COD. \_\_\_\_\_

DESCRIZIONE/DESCRIPTION/BEZEICHNUNG/DESCRIPTION/DESCRIPCIÓN  
DIMENSIONI/DIMENSIONS/ABMESSUNGEN/DIMENSIONS/DIMENSIONES

POTENZA/POWER/LEISTUNG/PUISSANCE/POTENCIA  
VOLTAGGIO/VOLTAGE/SPANNUNG/VOLTAGE/VOLTAJE

⚡ kW kcal/h  
V~ Hz

PREZZO/PRICE €  
PREIS/PRIX/PRECIO €  
KG / M<sup>3</sup>

CP-94ET  
09100430

**CUOCIPASTA TRIFASE LT. 40 VASCA CM. 30,7X50,9X32,7H. RUBINETTO CARICO ACQUA, SFIORATORE + SCARICO A PAVIMENTO (CESTI ESCLUSI) (INCLUSA 1 TESTATA CHIUSURA PIANO MOD.TPA-9)**  
**EN** Pasta cooker threephase 40 lts. Tank cm. 30,7x50,9x32,7h. Water loading tap + overflow device and floor draining (BASKETS EXCLUDED) (included 1 Head end filler strip mod.TPA-9) • **DE** Nudelkocher dreiphasig lt. 40 - Becken cm. 30,7x50,9x32,7h. Wasserlauf-Hahn + Überlauf-Vorrichtung und Ablauf am Boden (KORB AUSGESCHLOSSEN) (inbegriffen 1 Abschluss-Element mod.TPA-9) • **FR** Cuiseur a pates triphase lt. 40 Cuve cm.30,7x50,9x32,7h. Robinet d'arrivée d'eau trop plein + système de vidange au sol (PANIERS EXCLUS) (inclus 1 Élément de jonction top mod.TPA-9) • **ES** Cuece pasta trifásico lt. 40 - Cuba cm. 30,7x50,9x32,7h. Grifo carga agua + vertedero + descarga a pavimento (CESTAS EXCLUIDAS) (incluida 1 Chapa de cierre para top mod.TPA-9)  
**cm. 40x 90x 90h**



⚡ 13,5 kW 2.959,00  
400V~3N 57 / 0,46  
50/60 Hz

## COMBINAZIONI

- Combinations / • Zusammenstellungen
- Combinaisons / • Combinación múltiple

1/1	1/2	1/3	1/3	1/6 1/6	1/6 1/6
	1/2	1/3	2/3	1/3	1/6 1/6
		1/3		1/3	1/6 1/6

CPA-94ET  
09100435

**CUOCIPASTA TRIFASE LT. 40 VASCA CM. 30,7X50,9X32,7H. CARICO ACQUA AUTOMATICO CON SENSORE DI LIVELLO - SFIORATORE + SCARICO A PAVIMENTO (CESTI ESCLUSI) (INCLUSA 1 TESTATA CHIUSURA PIANO MOD.TPA-9)**  
**EN** Pasta cooker threephase 40 lts. Tank cm. 30,7x50,9x32,7h. Automatic Water loading with level sensor - overflow device and floor draining (BASKETS EXCLUDED) (included 1 Head end filler strip mod.TPA-9) • **DE** Nudelkocher dreiphasig lt. 40 - Becken cm. 30,7x50,9x32,7h. Automatische Wasser Beladung mit Niveauregulierung + Überlauf-Vorrichtung und Ablauf am Boden (KORB AUSGESCHLOSSEN) (inbegriffen 1 Abschluss-Element mod.TPA-9) • **FR** Cuiseur a pates triphase lt. 40 Cuve cm.30,7x50,9x32,7h. Chargement automatique de l'eau avec sensor de niveau, trop plein Système de vidange au sol (PANIERS EXCLUS) (inclus 1 Élément de jonction top mod.TPA-9) • **ES** Cuece pasta trifásico lt. 40 - Cuba cm. 30,7x50,9x32,7h. Carga automática de agua con sensor de nivel + vertedero + descarga a pavimento. (CESTAS EXCLUIDAS) (incluida 1 Chapa de cierre para top mod.TPA-9)  
**cm. 40x 90x 90h**



⚡ 13,5 kW 3.343,00  
400V~3N 57 / 0,46  
50/60 Hz

## COMBINAZIONI

- Combinations / • Zusammenstellungen
- Combinaisons / • Combinación múltiple

1/1	1/2	1/3	1/3	1/6 1/6	1/6 1/6
	1/2	1/3	2/3	1/3	1/6 1/6
		1/3		1/3	1/6 1/6



Le immagini presentate non sono vincolanti. La ditta si riserva di apportare modifiche senza preavviso. • The pictures are purely representative. The manufacturer reserves the right to modify the technical data and models without previous notice. • Les images

LO

présentées ne nous engagent pas. La Société se réserve le droit d'apporter tout modification sans préavis. • Die dargestellten Abbildungen sind nicht verbindlich. Technische Änderungen vorbehalten. • Las imágenes presentadas no son vinculantes. El Fabricante se reserva el derecho de modificar sus productos sin previo aviso.

01/20

251

90

MOD. \_\_\_\_\_  
COD. \_\_\_\_\_

DESCRIZIONE/DESCRIPTION/BEZEICHNUNG/DESCRIPTION/DESCRIPCIÓN  
DIMENSIONI/DIMENSIONS/ABMESSUNGEN/DIMENSIONS/DIMENSIONES

POTENZA/POWER/LEISTUNG/PUISSANCE/POTENCIA  
VOLTAGGIO/VOLTAGE/SPANNUNG/VOLTAGE/VOLTAJE

⚡ kW  
400V~3N  
50/60 Hz

PREZZO/PRICE €  
PREIS/PRIX/PRECIO €  
KG / M<sup>3</sup>

**CP-98ET**  
09100830

**CUOCIPASTA TRIFASE LT. 40+40 2 VASCHE  
CM. 30,7X50,9X32,7H. RUBINETTO  
CARICO ACQUA, SFIORATORE + SCARICO  
A PAVIMENTO (CESTI ESCLUSI) (INCLUSA 1  
TESTATA CHIUSURA PIANO MOD.TPA-9)**  
**EN** Pasta cooker threephase 40+40 lts. 2 Tanks cm.  
30,7x50,9x32,7h. Water loading tap + overflow device  
and floor draining (BASKETS EXCLUDED) (included 1  
Head end filler strip mod.TPA-9) • **DE** Nudelkocher  
dreiphasig lt. 40+40 2 Becken cm. 30,7x50,9x32,7h.  
Wasserlauf-Hahn + Überlauf-Vorrichtung und Ablauf  
am Boden (KORB AUSGESCHLOSSEN) (inbegriffen 1  
Abschluss-Element mod.TPA-9) • **FR** Cuiseur a pates  
triphase lt. 40+40 2 Cuves cm.30,7x50,9x32,7h.  
Robinet d'arrivée d'eau trop plein + système de vidange  
au sol (PANIERS EXCLUS) (inclus 1 Élément de jonction  
top mod.TPA-9) • **ES** Cuece pasta trifásico 40+40 lt.  
2 Cubas cm. 30,7x50,9x32,7h. Grifo carga agua +  
vertedero + descarga a pavimento (CESTAS EXCLUIDAS)  
(incluida 1 Chapa de cierre para top mod.TPA-9)  
**cm. 80x 90x 90h**



⚡ 27 kW  
400V~3N  
50/60 Hz

**4.943,00**  
98 / 0,89

### COMBINAZIONI

- Combinations / • Zusammenstellungen
- Combinaisons / • Combinación múltiple

1/1	1/2	1/3	1/3	1/6 1/6	1/6 1/6
	1/2	1/3	2/3	1/3	1/6 1/6
		1/3		1/3	1/6 1/6

**CPA-98ET**  
09100835

**CUOCIPASTA TRIFASE LT. 40+40 2 VASCHE  
CM. 30,7X50,9X32,7H. CARICO ACQUA  
AUTOMATICO CON SENSORE DI LIVELLO -  
SFIORATORE + SCARICO A PAVIMENTO (CESTI  
ESCLUSI) (INCLUSA 1 TESTATA CHIUSURA  
PIANO MOD.TPA-9)**  
**EN** Pasta cooker threephase 40+40 lts. 2 Tanks cm.  
30,7x50,9x32,7h. Automatic Water loading with level  
sensor - overflow device and floor draining (BASKETS  
EXCLUDED) (included 1 Head end filler strip mod.TPA-9)  
• **DE** Nudelkocher dreiphasig lt. 40+40 2 Becken cm.  
30,7x50,9x32,7h. Automatische Wasser Beladung mit  
Niveauregulierung + Überlauf-Vorrichtung und Ablauf  
am Boden (KORB AUSGESCHLOSSEN) (inbegriffen 1  
Abschluss-Element mod.TPA-9) • **FR** Cuiseur a pates  
triphase lt. 40+40 2 Cuves cm.30,7x50,9x32,7h.  
Chargement automatique de l'eau avec sensor de  
niveau, trop plein Système de vidange au sol (PANIERS  
EXCLUS) (inclus 1 Élément de jonction top mod.TPA-9)  
• **ES** Cuece pasta trifásico 40+40 lt. 2 Cubas cm.  
30,7x50,9x32,7h. Carga automática de agua con  
sensor de nivel + vertedero + descarga a pavimento.  
(CESTAS EXCLUIDAS) (incluida 1 Chapa de cierre para  
top mod.TPA-9)  
**cm. 80x 90x 90h**



⚡ 27 kW  
400V~3N  
50/60 Hz

**5.712,00**  
98 / 0,89

### COMBINAZIONI

- Combinations / • Zusammenstellungen
- Combinaisons / • Combinación múltiple

1/1	1/2	1/3	1/3	1/6 1/6	1/6 1/6
	1/2	1/3	2/3	1/3	1/6 1/6
		1/3		1/3	1/6 1/6

# CUOCIPASTA ELETTRICI

MOD. \_\_\_\_\_  
COD. \_\_\_\_\_

DESCRIZIONE/DESCRIPTION/BEZEICHNUNG/DESCRIPTION/DESCRIPCIÓN  
DIMENSIONI/DIMENSIONS/ABMESSUNGEN/DIMENSIONS/DIMENSIONES

POTENZA/POWER/LEISTUNG/PUISSANCE/POTENCIA  
VOLTAGGIO/VOLTAGE/SPANNUNG/VOLTAGE/VOLTAJE

⚡ kcal/h  
⚡ kW  
V~  
Hz

PREZZO/PRICE €  
PREIS/PRIX/PRECIO  
KG / M<sup>3</sup>

CPB-98ET  
09100831

**CUOCIPASTA TRIFASE LT. 80 VASCA CM. 62X50,9X32,7H. RUBINETTO CARICO ACQUA, SFIORATORE + SCARICO A PAVIMENTO (CESTI ESCLUSI) (INCLUSA 1 TESTATA CHIUSURA PIANO MOD.TPA-9)**

**EN** Pasta cooker threephase 80 lts. - Tank cm. 62x50,9x32,7h. Water loading tap + overflow device and floor draining (BASKETS EXCLUDED) (included 1 Head end filler strip mod.TPA-9) • **DE** Nudelkocher dreiphasig lt. 80 - Becken cm. 62x50,9x32,7h. Wasserlauf-Hahn + Überlauf-Vorrichtung und Ablauf am Boden (KORB AUSGESCHLOSSEN) (inbegriffen 1 Abschluss-Element mod.TPA-9) • **FR** Cuiseur a pates triphase lt. 80 - Cuve cm. 62x50,9x32,7h. Robinet d'arrivée d'eau trop plein + système de vidange au sol (PANIERS EXCLUS) (inclus 1 Élément de jonction top mod.TPA-9) • **ES** Cuece pasta trifásico lt. 80 - Cuba cm. 62x50,9x32,7h. Grifo carga agua + vertedero + descarga a pavimento (CESTAS EXCLUIDAS) (incluida 1 Chapa de cierre para top mod.TPA-9)  
**cm. 80x 90x 90h**



⚡ 27 kW  
400V~3N  
50/60 Hz

**4.505,00**  
93 / 0,89

## COMBINAZIONI

- Combinations / • Zusammenstellungen
- Combinaisons / • Combinación múltiple

1/1	1/2	1/3	1/3	1/6 1/6	1/6 1/6
	1/2	1/3	2/3	1/3	1/6 1/6
		1/3		1/3	1/6 1/6

CP-94G  
09270450

**CUOCIPASTA GAS LT. 40 VASCA CM. 30,7X50,9X32,7H. RUBINETTO CARICO ACQUA, SFIORATORE + SCARICO A PAVIMENTO (CESTI ESCLUSI) (INCLUSA 1 TESTATA CHIUSURA PIANO MOD.TPA-9)**

**EN** Gas pasta cooker 40 lts. - Tank cm. 30,7x50,9x32,7h. Water loading tap + overflow device and floor draining (BASKETS EXCLUDED) (included 1 Head end filler strip mod.TPA-9) • **DE** Gas-Nudelkocher lt. 40 - Becken cm. 30,7x50,9x32,7h. Wasserlauf-Hahn + Überlauf-Vorrichtung und Ablauf am Boden (KORB AUSGESCHLOSSEN) (inbegriffen 1 Abschluss-Element mod.TPA-9) • **FR** Cuiseur a pates gaz lt. 40 - Cuve cm.30,7x50,9x32,7h. Robinet d'arrivée d'eau trop plein Système de vidange au sol (PANIERS EXCLUS) (inclus 1 Élément de jonction top mod.TPA-9) • **ES** Cuece pasta gas 40 lt. - Cuba cm. 30,7x50,9x32,7h. Grifo carga agua + vertedero + descarga a pavimento. (CESTAS EXCLUIDAS) (incluida 1 Chapa de cierre para top mod. TPA-9)  
**cm. 40x 90x 90h**



⚡ 13,95 kW  
11.997 kcal/h

**3.070,00**  
68 / 0,46

⚡ 0,02 kW  
230V~  
50/60 Hz

## COMBINAZIONI

- Combinations / • Zusammenstellungen
- Combinaisons / • Combinación múltiple

1/1	1/2	1/3	1/3	1/6 1/6	1/6 1/6
	1/2	1/3	2/3	1/3	1/6 1/6
		1/3		1/3	1/6 1/6



Le immagini presentate non sono vincolanti. La ditta si riserva di apportare modifiche senza preavviso. • The pictures are purely representative. The manufacturer reserves the right to modify the technical data and models without previous notice. • Les images

LO

présentées ne nous engagent pas. La Société se réserve le droit d'apporter tout modification sans préavis. • Die dargestellten Abbildungen sind nicht verbindlich. Technische Änderungen vorbehalten. • Las imágenes presentadas no son vinculantes. El Fabricante se reserva el derecho de modificar sus productos sin previo aviso.

01/20

253



MOD. \_\_\_\_\_  
COD. \_\_\_\_\_

DESCRIZIONE/DESCRIPTION/BEZEICHNUNG/DESCRIPTION/DESCRIPCIÓN  
DIMENSIONI/DIMENSIONS/ABMESSUNGEN/DIMENSIONS/DIMENSIONES

POTENZA/POWER/LEISTUNG/PUISSANCE/POTENCIA  
VOLTAGGIO/VOLTAGE/SPANNUNG/VOLTAGE/VOLTAJE

⚡ kW  
kcal/h

⚡ kW  
V~  
Hz

PREZZO/PRICE €  
PREIS/PRIX/PRECIO €  
KG / M<sup>3</sup>

**CPA-94G**  
09270455

**CUOCIPASTA GAS LT. 40 VASCA CM. 30,7X50,9X32,7H. CARICO ACQUA AUTOMATICO CON SENSORE DI LIVELLO - SFIORATORE + SCARICO A PAVIMENTO (CESTI ESCLUSI) (INCLUSA 1 TESTATA CHIUSURA PIANO MOD.TPA-9)**

**EN** Gas pasta cooker 40 lts. - Tank cm. 30,7x50,9x32,7h. Automatic Water loading with level sensor - overflow device and floor draining (BASKETS EXCLUDED) (included 1 Head end filler strip mod. TPA-9) • **DE** Gas-Nudelkocher lt. 40 - Becken cm. 30,7x50,9x32,7h. Automatische Wasser Beladung mit Niveauregulierung + Überlauf-Vorrichtung und Ablauf am Boden (KORB AUSGESCHLOSSEN) (inbegriffen 1 Abschluss-Element mod.TPA-9) • **FR** Cuiseur a pates gaz lt. 40 - Cuve cm.30,7x50,9x32,7h. Chargement automatique de l'eau avec sensor de niveau, trop plein Système de vidange au sol (PANIERS EXCLUS) (inclus 1 Élément de jonction top mod.TPA-9) • **ES** Cuece pasta gas 40 lt. - Cuba cm. 30,7x50,9x32,7h. Carga automática de agua con sensor de nivel + vertedero + descarga a pavimento. (CESTAS EXCLUIDAS) (incluida 1 Chapa de cierre para top mod.TPA-9)  
**cm. 40x 90x 90h**



⚡ 13,95 kW  
11.997 kcal/h **3.291,00**  
68 / 0,46

⚡ 0,035 KW  
230V~  
50/60 Hz

### COMBINAZIONI

- Combinations / • Zusammenstellungen
- Combinaisons / • Combinación múltiple

1/1	1/2	1/3	1/3	1/6/1/6	1/6/1/6
	1/2	1/3	2/3	1/3	1/6/1/6
		1/3		1/3	1/6/1/6

**CP-98G**  
09270850

**CUOCIPASTA GAS LT. 40+40 2 VASCHE CM. 30,7X50,9X32,7H. RUBINETTO CARICO ACQUA, SFIORATORE + SCARICO A PAVIMENTO (CESTI ESCLUSI) (INCLUSA 1 TESTATA CHIUSURA PIANO MOD.TPA-9)**

**EN** Gas pasta cooker 40+40 lts 2 Tanks cm. 30,7x50,9x32,7h. Water loading, tap + overflow device and floor draining (BASKETS EXCLUDED) (included 1 Head end filler strip mod.TPA-9) • **DE** Gas-Nudelkocher lt. 40+40 2 Becken cm. 30,7x50,9x32,7h. Wasserlauf-Hahn, Überlauf-Vorrichtung und Ablauf am Boden (KORB AUSGESCHLOSSEN) (inbegriffen 1 Abschluss-Element mod.TPA-9) • **FR** Cuiseur a pates gaz lt. 40+40 2 Cuve cm. 30,7x50,9x32,7h. Robinet d'arrivée d'eau trop plein + système de vidange au sol (PANIERS EXCLUS) (inclus 1 Élément de jonction top mod.TPA-9) • **ES** Cuece pasta gas 40+40 lt. 2 Cubas cm. 30,7x50,9x32,7h. Grifo carga agua + vertedero + descarga a pavimento (CESTAS EXCLUIDAS) (incluida 1 Chapa de cierre para top mod.TPA-9)  
**cm. 80x 90x 90h**



⚡ 27,9 kW  
23.994 kcal/h **5.192,00**  
116 / 0,89

⚡ 0,04 KW  
230V~  
50/60 Hz

### COMBINAZIONI

- Combinations / • Zusammenstellungen
- Combinaisons / • Combinación múltiple

1/1	1/2	1/3	1/3	1/6/1/6	1/6/1/6
	1/2	1/3	2/3	1/3	1/6/1/6
		1/3		1/3	1/6/1/6

MOD. \_\_\_\_\_  
COD. \_\_\_\_\_

DESCRIZIONE/DESCRIPTION/BEZEICHNUNG/DESCRIPTION/DESCRIPCIÓN  
DIMENSIONI/DIMENSIONS/ABMESSUNGEN/DIMENSIONS/DIMENSIONES

POTENZA/POWER/LEISTUNG/PUISSANCE/POTENCIA  
VOLTAGGIO/VOLTAGE/SPANNUNG/VOLTAGE/VOLTAJE

⚡ kW kcal/h  
⚡ kW V~ Hz

PREZZO/PRICE €  
PREIS/PRIX/PRECIO €  
KG / M<sup>3</sup>

**CPA-98G**  
09270855

**CUOCIPASTA GAS LT. 40+40 2 VASCHE CM. 30,7X50,9X32,7H. CARICO ACQUA AUTOMATICO CON SENSORE DI LIVELLO - SFIORATORE + SCARICO A PAVIMENTO (CESTI ESCLUSI) (INCLUSA 1 TESTATA CHIUSURA PIANO MOD.TPA-9)**

**EN** Gas pasta cooker 40+40 lts 2 Tanks cm. 30,7x50,9x32,7h. Automatic Water loading with level sensor - overflow device and floor draining (BASKETS EXCLUDED) (included 1 Head end filler strip mod. TPA-9) • **DE** Gas-Nudelkocher lt. 40+40 2 Becken cm. 30,7x50,9x32,7h. Automatische Wasser Beladung mit Niveauregulierung + Überlauf-Vorrichtung und Ablauf am Boden (KORB AUSGESCHLOSSEN) (inbegriffen 1 Abschluss-Element mod.TPA-9) • **FR** Cuiseur a pates gaz lt. 40+40 2 Cuve cm. 30,7x50,9x32,7h. Chargement automatique de l'eau avec sensor de niveau, trop plein Système de vidange au sol (PANIERS EXCLUS) (inclus 1 Élément de jonction top mod. TPA-9) • **ES** Cuece pasta gas 40+40 lt. 2 Cubas cm. 30,7x50,9x32,7h. Carga automática de agua con sensor de nivel + vertedero + descarga a pavimento. (CESTAS EXCLUIDAS) (incluida 1 Chapa de cierre para top mod.TPA-9)

**cm. 80x 90x 90h**



⚡ 27,9 kW 23.994 kcal/h **5.631,00**  
116 / 0,89

⚡ 0,07 KW  
230V~  
50/60 Hz

### COMBINAZIONI

- Combinations / • Zusammenstellungen
- Combinaisons / • Combinación múltiple

1/1	1/2	1/3	1/3	1/6 1/6	1/6 1/6
	1/2	1/3	2/3	1/3	1/6 1/6
		1/3		1/3	1/6 1/6

**CPB-98G**  
09270851

**CUOCIPASTA GAS LT. 80 VASCA CM. 62X50,9X32,7H. RUBINETTO CARICO ACQUA, SFIORATORE + SCARICO A PAVIMENTO (CESTI ESCLUSI) (INCLUSA 1 TESTATA CHIUSURA PIANO MOD.TPA-9)**

**EN** Gas pasta cooker 80 lts. - Tank cm. 62x50,9x32,7h. Water loading tap + overflow device and floor draining (BASKETS EXCLUDED) (included 1 Head end filler strip mod.TPA-9) • **DE** Gas-Nudelkocher lt. 80. - Becken cm. 62x50,9x32,7h. Wasserlauf-Hahn + Überlauf-Vorrichtung und Ablauf am Boden (KORB AUSGESCHLOSSEN) (inbegriffen 1 Abschluss-Element mod.TPA-9) • **FR** Cuiseur a pates gaz lt. 80 - Cuve cm. 62x50,9x32,7h. Robinet d'arrivée d'eau trop plein + système de vidange au sol (PANIERS EXCLUS) (inclus 1 Élément de jonction top mod.TPA-9) • **ES** Cuece pasta gas 80 lt. - Cuba cm. 62x50,9x32,7h. Grifo carga agua + vertedero + descarga a pavimento (CESTAS EXCLUIDAS) (incluida 1 Chapa de cierre para top mod. TPA-9)

**cm. 80x 90x 90h**



⚡ 31,5 kW 27.060 kcal/h **4.581,00**  
110 / 0,89

⚡ 0,02 KW  
230V~  
50/60 Hz

### COMBINAZIONI

- Combinations / • Zusammenstellungen
- Combinaisons / • Combinación múltiple

1/1	1/2	1/3	1/3	1/6 1/6	1/6 1/6
	1/2	1/3	2/3	1/3	1/6 1/6
		1/3		1/3	1/6 1/6

# CUOCIPASTA A GAS POTENZIATO

MOD. \_\_\_\_\_  
COD. \_\_\_\_\_

DESCRIZIONE/DESCRIPTION/BEZEICHNUNG/DESCRIPTION/DESCRIPCIÓN  
DIMENSIONI/DIMENSIONS/ABMESSUNGEN/DIMENSIONS/DIMENSIONES

POTENZA/POWER/LEISTUNG/PUISSANCE/POTENCIA  
VOLTAGGIO/VOLTAGE/SPANNUNG/VOLTAGE/VOLTAJE

⚡ kW kcal/h  
⚡ kW V~ Hz

PREZZO/PRICE €  
PREIS/PRIX/PRECIO €  
KG / M<sup>3</sup>

CPP-94G  
09270452

**CUOCIPASTA GAS POTENZIATO LT. 40 VASCA CM. 30,7X50,9X32,7H. RUBINETTO CARICO ACQUA, SFIORATORE + SCARICO A PAVIMENTO (CESTI ESCLUSI) (INCLUDE ENTRAMBE LE TESTATE CHIUSURA PIANO)**  
**EN** Powerfull Gas pasta cooker 40 lts. - Tank cm. 30,7x50,9x32,7h. Water loading tap + overflow device and floor draining (BASKETS EXCLUDED) (included both Heads end filler strip) • **DE** Gas-Nudelkocher leistungsfähiges lt. 40 - Becken cm. 30,7x50,9x32,7h. Wasserlauf-Hahn + Überlauf-Vorrichtung und Ablauf am Boden (KORB AUSGESCHLOSSEN) (inbegriffen alle 2 Abschluss-Element) • **FR** Cuiseur a pates gaz plus puissants lt. 40 - Cuve cm.30,7x50,9x32,7h. Robinet d'arrivée d'eau trop plein Système de vidange au sol (PANIERS EXCLUS) (inclus tous 2 Élément de jonction top) • **ES** Cuece pasta gas con mayor potencia 40 lt. - Cuba cm. 30,7x50,9x32,7h. Grifo carga agua + vertedero + descarga a pavimento. (CESTAS EXCLUIDAS) (incluidas todas las 2 Chapa de cierre para top)  
**cm. 40x 90x 90h**



⚡ 23,5 kW 3.486,00  
20.210 kcal/h 69 / 0,54  
⚡ 0,02 KW  
230V~  
50/60 Hz

## COMBINAZIONI

- Combinations / • Zusammenstellungen
- Combinaisons / • Combinación múltiple

1/1	1/2	1/3	1/3	1/6/1/6	1/6/1/6
	1/2	1/3	2/3	1/3	1/6/1/6
		1/3		1/3	1/6/1/6

CPPA-94G  
09270457

**CUOCIPASTA GAS POTENZIATO LT. 40 VASCA CM. 30,7X50,9X32,7H. CARICO ACQUA AUTOMATICO CON SENSORE DI LIVELLO - SFIORATORE + SCARICO A PAVIMENTO (CESTI ESCLUSI) (INCLUDE ENTRAMBE LE TESTATE CHIUSURA PIANO)**  
**EN** Powerfull Gas pasta cooker 40 lts. - Tank cm. 30,7x50,9x32,7h. Automatic Water loading with level sensor - overflow device and floor draining (BASKETS EXCLUDED) (included both Heads end filler strip) • **DE** Gas-Nudelkocher leistungsfähiges lt. 40 - Becken cm. 30,7x50,9x32,7h. Automatische Wasser Beladung mit Niveauregulierung + Überlauf-Vorrichtung und Ablauf am Boden (KORB AUSGESCHLOSSEN) (inbegriffen alle 2 Abschluss-Element) • **FR** Cuiseur a pates gaz plus puissants lt. 40 - Cuve cm.30,7x50,9x32,7h. Chargement automatique de l'eau avec sensor de niveau, trop plein Système de vidange au sol (PANIERS EXCLUS) (inclus tous 2 Élément de jonction top) • **ES** Cuece pasta gas con mayor potencia 40 lt. - Cuba cm. 30,7x50,9x32,7h. Carga automática de agua con sensor de nivel + vertedero + descarga a pavimento. (CESTAS EXCLUIDAS) (incluidas todas las 2 Chapa de cierre para top)  
**cm. 40x 90x 90h**



⚡ 23,5 kW 3.700,00  
20.210 kcal/h 69 / 0,54  
⚡ 0,035 KW  
230V~  
50/60 Hz

## COMBINAZIONI

- Combinations / • Zusammenstellungen
- Combinaisons / • Combinación múltiple

1/1	1/2	1/3	1/3	1/6/1/6	1/6/1/6
	1/2	1/3	2/3	1/3	1/6/1/6
		1/3		1/3	1/6/1/6

# SOLLEVATORE CESTI

MOD. \_\_\_\_\_  
COD. \_\_\_\_\_

DESCRIZIONE/DESCRIPTION/BEZEICHNUNG/DESCRIPTION/DESCRIPCIÓN  
DIMENSIONI/DIMENSIONS/ABMESSUNGEN/DIMENSIONS/DIMENSIONES

POTENZA/POWER/LEISTUNG/PUISSANCE/POTENCIA  
VOLTAGGIO/VOLTAGE/SPANNUNG/VOLTAGE/VOLTAJE

⚡ kW kcal/h  
V~ Hz

PREZZO/PRICE €  
PREIS/PRIX/PRECIO KG / M<sup>3</sup>

**SCCP-92EM SOLLEVATORE CESTI DA AFFIANCARE AI CUOCIPASTA CP-94/98, SOLLEVAMENTO AUTOMATICO TEMPORIZZATO O MANUALE, 3 ASTE (INCLUSA 1 TESTATA CHIUSURA PIANO MOD.TPA-9)**

09140210

**EN** basket elevator for pasta cooker CP-94/98, automatic timed or manual lifting, 3 rods (included 1 Head end filler strip mod.TPA-9) • **DE** heben Korbe für Nudelkocher CP-94/98, Timed oder manuelle Heben, 3 Stangen (inbegriffen 1 Abschluss-Element mod. TPA-9) • **FR** soulever des paniers pour cuiseur a pates CP-94/98, soulèvement temporisé ou manuel, 3 tiges (inclus 1 Élément de jonction top mod.TPA-9) • **ES** levante cestas para cuece pasta CP-94/98, elevación temporizado o manual, 3 barras (incluida 1 Chapa de cierre para top mod.TPA-9)  
**cm. 20x 90x 90h**



⚡ 0,525 KW 3.583,00  
230V~ 65 / 0,46  
50/60 Hz

**COMBINAZIONI**

- Combinations / • Zusammenstellungen
- Combinaisons / • Combinación múltiple

1/1	1/2	1/3	1/3	1/6
	1/2	1/3	2/3	1/6
		1/3		1/6

**SCCPB-92EM SOLLEVATORE CESTI DA AFFIANCARE AI CUOCIPASTA CPB-98, SOLLEVAMENTO AUTOMATICO TEMPORIZZATO O MANUALE, 3 ASTE (INCLUSA 1 TESTATA CHIUSURA PIANO MOD.TPA-9)**

09140211

**EN** basket elevator for pasta cooker CPB-98, automatic timed or manual lifting, 3 rods (included 1 Head end filler strip mod.TPA-9) • **DE** heben Korbe für Nudelkocher CPB-98, Timed oder manuelle Heben, 3 Stangen (inbegriffen 1 Abschluss-Element mod.TPA-9) • **FR** soulever des paniers pour cuiseur a pates CPB-98, soulèvement temporisé ou manuel, 3 tiges (inclus 1 Élément de jonction top mod.TPA-9) • **ES** levante cestas para cuece pasta CPB-98, elevación temporizado o manual, 3 barras (incluida 1 Chapa de cierre para top mod.TPA-9)  
**cm. 20x 90x 90h**

⚡ 0,525 KW 3.583,00  
230V~ 65 / 0,46  
50/60 Hz

**COMBINAZIONI**

- Combinations / • Zusammenstellungen
- Combinaisons / • Combinación múltiple

1/1	1/2	1/3	1/3	1/6
	1/2	1/3	2/3	1/6
		1/3		1/6

**PI100-98ET PENTOLA INDIRETTA ELETTRICA LT.100 VASCA Ø CM. 60X42H (INCLUSA 1 TESTATA CHIUSURA PIANO MOD.TPA-9)**

09110831

**EN** Electric indirect boiling pan 100 lts. Tank Ø cm. 60x42h (included 1 Head end filler strip mod.TPA-9) • **DE** Indirekter Elektro-Kochkessel lt. 100 Becken Ø cm. 60x42h (inbegriffen 1 Abschluss-Element mod.TPA-9) • **FR** Marmite indirecte électrique lt. 100 Cuve Ø cm. 60x42h (inclus 1 Élément de jonction top mod.TPA-9) • **ES** Marmite de calefacción indirecta 100 lt. Cuba Ø cm. 60x42h (incluida 1 Chapa de cierre para top mod. TPA-9)  
**cm. 80x 90x 90h**



⚡ 16 kW 7.313,00  
400V~3N 107 / 1,07  
50/60 Hz



Le immagini presentate non sono vincolanti. La ditta si riserva di apportare modifiche senza preavviso. • The pictures are purely representative. The manufacturer reserves the right to modify the technical data and models without previous notice. • Les images

LO

présentées ne nous engagent pas. La Société se réserve le droit d'apporter tout modification sans préavis. • Die dargestellten Abbildungen sind nicht verbindlich. Technische Änderungen vorbehalten. • Las imágenes presentadas no son vinculantes. El Fabricante se reserva el derecho de modificar sus productos sin previo aviso.

01/20

257

MOD. \_\_\_\_\_  
COD. \_\_\_\_\_

DESCRIZIONE/DESCRIPTION/BEZEICHNUNG/DESCRIPTION/DESCRIPCIÓN  
DIMENSIONI/DIMENSIONS/ABMESSUNGEN/DIMENSIONS/DIMENSIONES

POTENZA/POWER/LEISTUNG/PUISSANCE/POTENCIA  
VOLTAGGIO/VOLTAGE/SPANNUNG/VOLTAGE/VOLTAJE

⚡ kW kcal/h  
V~ Hz

PREZZO/PRICE €  
PREIS/PRIX/PRECIO €  
KG / M<sup>3</sup>

**PI100A-98ET PENTOLA INDIRETTA ELETTRICA LT. 100 VASCA  
Ø CM. 60X42H - CARICO AUTOMATICO**

0911A831

**INTERCAPEDINE (INCLUSA 1 TESTATA  
CHIUSURA PIANO MOD.TPA-9)**

**EN** Electric indirect boiling pan 100 lts. Tank Ø cm. 60x42h - automatic water-charge of double jacket (included 1 Head end filler strip mod.TPA-9) • **DE** Indirekter Elektro-Kochkessel lt. 100 Becken Ø cm. 60x42h - automatische Wasserstandskontrolle im Zwischenmantel (inbegriffen 1 Abschluss-Element mod. TPA-9) • **FR** Marmite indirecte électrique lt. 100 Cuve Ø cm. 60x42h - remplissage automatique dans la double paroi (inclus 1 Élément de jonction top mod.TPA-9) • **ES** Marmita de calefacción indirecta 100 lt. Cuba Ø cm. 60x42h - carga automática de la camisa intercambiador (incluida 1 Chapa de cierre para top mod.TPA-9)  
**cm. 80x 90x 90h**



⚡ 16 kW **9.120,00**  
400V~3N 107 / 1,07  
50/60 Hz

**PIA100-98ET PENTOLA INDIRETTA ELETTRICA LT. 100**

09110833

**AUTOCLAVE - VASCA Ø CM. 60X42H  
(INCLUSA 1 TESTATA CHIUSURA PIANO MOD.  
TPA-9)**

**EN** Electric indirect boiling pan 100 lts. autoclave Tank Ø cm. 60x42h (included 1 Head end filler strip mod.TPA-9) • **DE** Indirekter Elektro-Kochkessel 100 lt. Druckkessel Becken Ø cm. 60x42h (inbegriffen 1 Abschluss-Element mod.TPA-9) • **FR** Marmite indirecte électrique 100 lt. autoclave Cuve Ø cm. 60x42h (inclus 1 Élément de jonction top mod.TPA-9) • **ES** Marmita de calefacción indirecta 100 lt. autoclave Cuba Ø cm. 60x42h (incluida 1 Chapa de cierre para top mod. TPA-9)  
**cm. 80x 90x 90h**

⚡ 16 kW **8.617,00**  
400V~3N 113 / 1,07  
50/60 Hz

**PIA100A-98ET PENTOLA INDIRETTA ELETTRICA LT. 100  
AUTOCLAVE - VASCA Ø CM. 60X42H - CARICO  
AUTOMATICO INTERCAPEDINE (INCLUSA 1  
TESTATA CHIUSURA PIANO MOD.TPA-9)**

0911A833

**EN** Electric indirect boiling pan 100 lts. autoclave Tank Ø cm. 60x42h - automatic water-charge of double jacket (included 1 Head end filler strip mod.TPA-9) • **DE** Indirekter Elektro-Kochkessel 100 lt. Druckkessel Becken Ø cm. 60x42h - automatische Wasserstandskontrolle im Zwischenmantel (inbegriffen 1 Abschluss-Element mod.TPA-9) • **FR** Marmite indirecte électrique 100 lt. autoclave Cuve Ø cm. 60x42h - remplissage automatique dans la double paroi (inclus 1 Élément de jonction top mod.TPA-9) • **ES** Marmita de calefacción indirecta 100 lt. autoclave Cuba Ø cm. 60x42h - carga automática de la camisa intercambiador (incluida 1 Chapa de cierre para top mod.TPA-9)  
**cm. 80x 90x 90h**

⚡ 16 kW **10.424,00**  
400V~3N 113 / 1,07  
50/60 Hz

**PD100-98G PENTOLA DIRETTA GAS LT.100 VASCA Ø CM.  
60X42H (INCLUSA 1 TESTATA CHIUSURA  
PIANO MOD.TPA-9)**

09280850

**EN** Gas direct boiling pan 100 lts. Tank Ø cm. 60x42h (included 1 Head end filler strip mod.TPA-9) • **DE** Direkter Gas-Kochkessel 100 lt. Becken Ø cm. 60x42h (inbegriffen 1 Abschluss-Element mod.TPA-9) • **FR** Marmite directe à gaz 100 lt. Cuve Ø cm. 60x42h (inclus 1 Élément de jonction top mod.TPA-9) • **ES** Marmita de calefacción directa lt. 100 Cuba Ø cm. 60x42h (incluida 1 Chapa de cierre para top mod. TPA-9)  
**cm. 80x 90x 90h**



⚡ 21 kW **5.776,00**  
18.060 kcal/h 106 / 1,07



# PENTOLE A GAS

MOD. \_\_\_\_\_  
COD. \_\_\_\_\_

DESCRIZIONE/DESCRIPTION/BEZEICHNUNG/DESCRIPTION/DESCRIPCIÓN  
DIMENSIONI/DIMENSIONS/ABMESSUNGEN/DIMENSIONS/DIMENSIONES

POTENZA/POWER/LEISTUNG/PUISSANCE/POTENCIA  
VOLTAGGIO/VOLTAGE/SPANNUNG/VOLTAGE/VOLTAJE

21 kW  
18.060 kcal/h

PREZZO/PRICE €  
PREIS/PRIX/PRECIO €  
KG / M<sup>3</sup>

**PDA100-98G PENTOLA DIRETTA GAS LT. 100 AUTOCLAVE**  
09280852 **VASCA Ø CM. 60X42H (INCLUSA 1 TESTATA**  
**CHIUSURA PIANO MOD.TPA-9)**

**EN** Gas direct boiling pan 100 lts. autoclave Tank Ø cm. 60x42h (included 1 Head end filler strip mod.TPA-9)  
• **DE** Direkter Gas-Kockessel 100 lt. Druckkessel Becken Ø cm. 60x42h (inbegriffen 1 Abschluss-Element mod. TPA-9) • **FR** Marmite directe à gaz 100 lt. autoclave Cuve Ø cm. 60x42h (inclus 1 Élément de jonction top mod.TPA-9) • **ES** Marmita de calefacción directa lt. 100 autoclave Cuba Ø cm. 60x42h (incluida 1 Chapa de cierre para top mod.TPA-9)  
**cm. 80x 90x 90h**



21 kW  
18.060 kcal/h

**7.095,00**  
111 / 1,07

**PI100-98G PENTOLA INDIRETTA GAS LT.100 VASCA Ø**  
09280851 **CM. 60X42H (INCLUSA 1 TESTATA CHIUSURA**  
**PIANO MOD.TPA-9)**

**EN** Gas indirect boiling pan 100 lts. Tank Ø cm. 60x42h (included 1 Head end filler strip mod.TPA-9)  
• **DE** Indirekter Gas-Kockessel 100 lt. Becken Ø cm. 60x42h (inbegriffen 1 Abschluss-Element mod.TPA-9)  
• **FR** Marmite indirecte à gaz 100 lt. Cuve Ø cm. 60x42h (inclus 1 Élément de jonction top mod.TPA-9)  
• **ES** Marmita de calefacción indirecta a gas lt. 100 Cuba Ø cm. 60x42h (incluida 1 Chapa de cierre para top mod.TPA-9)  
**cm. 80x 90x 90h**



21 kW  
18.060 kcal/h

**7.546,00**  
131 / 1,07

**PI100A-98G PENTOLA INDIRETTA GAS LT.100 VASCA**  
0928A851 **Ø CM. 60X42H - CARICO AUTOMATICO**  
**INTERCAPEDINE (INCLUSA 1 TESTATA**  
**CHIUSURA PIANO MOD.TPA-9)**

**EN** Gas indirect boiling pan 100 lts. Tank Ø cm. 60x42h - automatic water-charge of double jacket (included 1 Head end filler strip mod.TPA-9) • **DE** Indirekter Gas-Kockessel 100 lt. Becken Ø cm. 60x42h - automatische Wasserstandskontrolle im Zwischenmantel (inbegriffen 1 Abschluss-Element mod.TPA-9) • **FR** Marmite indirecte à gaz 100 lt. Cuve Ø cm. 60x42h - remplissage automatique dans la double paroi (inclus 1 Élément de jonction top mod.TPA-9) • **ES** Marmita de calefacción indirecta a gas lt. 100 Cuba Ø cm. 60x42h - carga automática de la camisa intercambiador (incluida 1 Chapa de cierre para top mod.TPA-9)  
**cm. 80x 90x 90h**

21 kW  
18.060 kcal/h

**9.503,00**  
131 / 1,07

0,1 KW  
230V~  
50/60 Hz

**PIA100-98G PENTOLA INDIRETTA GAS LT. 100 AUTOCLAVE**  
09280853 **VASCA Ø CM. 60X42H (INCLUSA 1 TESTATA**  
**CHIUSURA PIANO MOD.TPA-9)**

**EN** Gas indirect boiling pan 100 lts. - Autoclave Tank Ø cm. 60x42h (included 1 Head end filler strip mod.TPA-9)  
• **DE** Indirekter Gas-Kochkessel 100 lt. - Druckkessel Becken Ø cm. 60x42h (inbegriffen 1 Abschluss-Element mod.TPA-9) • **FR** Marmite indirecte gaz 100 lt. - Autoclave Cuve Ø cm. 60x42h (inclus 1 Élément de jonction top mod.TPA-9) • **ES** Marmita de calefacción indirecta 100 lt. - Autoclave Cuba Ø cm. 60x42h (incluida 1 Chapa de cierre para top mod.TPA-9)  
**cm. 80x 90x 90h**

21 kW  
18.060 kcal/h

**8.850,00**  
136 / 1,07



Le immagini presentate non sono vincolanti. La ditta si riserva di apportare modifiche senza preavviso. • The pictures are purely representative. The manufacturer reserves the right to modify the technical data and models without previous notice. • Les images

LO

présentées ne nous engagent pas. La Société se réserve le droit d'apporter tout modification sans préavis. • Die dargestellten Abbildungen sind nicht verbindlich. Technische Änderungen vorbehalten. • Las imágenes presentadas no son vinculantes. El Fabricante se reserva el derecho de modificar sus productos sin previo aviso.

01/20

**259**

90

MOD. \_\_\_\_\_  
COD. \_\_\_\_\_

DESCRIZIONE/DESCRIPTION/BEZEICHNUNG/DESCRIPTION/DESCRIPCIÓN  
DIMENSIONI/DIMENSIONS/ABMESSUNGEN/DIMENSIONS/DIMENSIONES

POTENZA/POWER/LEISTUNG/PUISSANCE/POTENCIA  
VOLTAGGIO/VOLTAGE/SPANNUNG/VOLTAGE/VOLTAJE

⚡ kW \_\_\_\_\_  
kcal/h \_\_\_\_\_  
⚡ kw \_\_\_\_\_  
V~ \_\_\_\_\_  
Hz \_\_\_\_\_

PREZZO/PRICE € \_\_\_\_\_  
PREIS/PRIX/PRECIO € \_\_\_\_\_  
KG / M<sup>3</sup> \_\_\_\_\_

**PIA100A-98G PENTOLA INDIRETTA GAS LT. 100**

0928A853

**AUTOCLAVE VASCA Ø CM. 60X42H - CARICO AUTOMATICO INTERCAPEDINE (INCLUSA 1 TESTATA CHIUSURA PIANO MOD.TPA-9)**

**EN** Gas indirect boiling pan 100 lts. - Autoclave Tank Ø cm. 60x42h - automatic water-charge of double jacket (included 1 Head end filler strip mod.TPA-9) • **DE** Indirekter Gas-Kochkessel 100 lt. - Druckkessel Becken Ø cm. 60x42h - automatische Wasserstandskontrolle im Zwischenmantel (inbegriffen 1 Abschluss-Element mod. TPA-9) • **FR** Marmite indirecte gaz 100 lt. - Autoclave Cuve Ø cm. 60x42h - remplissage automatique dans la double paroi (inclus 1 Élément de jonction top mod. TPA-9) • **ES** Marmita de calefacción indirecta 100 lt. - Autoclave Cuba Ø cm. 60x42h - carga automática de la camisa intercambiador (incluida 1 Chapa de cierre para top mod.TPA-9)

**cm. 80x 90x 90h**



⚡ 21 kW \_\_\_\_\_ **10.807,00**  
18.060 kcal/h \_\_\_\_\_ 136 / 1,07

⚡ 0,1 kW \_\_\_\_\_  
230V~ \_\_\_\_\_  
50/60 Hz \_\_\_\_\_

**531043401 OPTIONAL: CESTO 1/1 PER PENTOLA 100 LT**

**EN** Optional: Basket 1/1 for boiling pan • **DE** Zubehör: Korb 1/1 für Kochkessel • **FR** En option: Panier 1/1 pour marmite • **ES** Opcional: Cesta 1/1 por marmita

**cm. Ø 56x 34,5h**

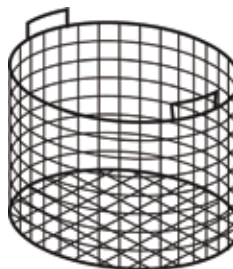

**932,00**  
5 / 0,18

**531043501 OPTIONAL: CESTO 1/1 PER PENTOLA 150 LT**

**EN** Optional: Basket 1/1 for boiling pan • **DE** Zubehör: Korb 1/1 für Kochkessel • **FR** En option: Panier 1/1 pour marmite • **ES** Opcional: Cesta 1/1 por marmita

**cm. Ø 56x 47h**

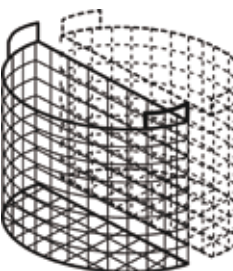

**973,00**  
5 / 0,22

**531043601 OPTIONAL: CESTO 1/2 PER PENTOLA 100 LT**

**EN** Optional: Basket 1/2 for boiling pan • **DE** Zubehör: Korb 1/2 für Kochkessel • **FR** En option: Panier 1/2 pour marmite • **ES** Opcional: Cesta 1/2 por marmita

**cm. Ø 56x 34,5h**



**570,00**  
2.5 / 0,11

**531043701 OPTIONAL: CESTO 1/2 PER PENTOLA 150 LT**

**EN** Optional: Basket 1/2 for boiling pan • **DE** Zubehör: Korb 1/2 für Kochkessel • **FR** En option: Panier 1/2 pour marmite • **ES** Opcional: Cesta 1/2 por marmita

**cm. Ø 56x 47h**

**694,00**  
2.5 / 0,13

**ISP**

09580020

**OPTIONAL: IMBUTO PER SCARICO PENTOLE**

**EN** Optional: Channel for pan drainage • **DE** Zubehör: Trichter zum Entleeren der Töpfe • **FR** En option: Entonnoir pour vidange marmites • **ES** Opcional: Embudo para descargar marmitas



**123,00**  
5 / 0,04

**PI150-98ET PENTOLA INDIRETTA ELETTRICA LT. 135**

09110836

**VASCA Ø CM. 60X54H (INCLUSA 1 TESTATA CHIUSURA PIANO MOD.TPA-9)**

**EN** Electric indirect boiling pan 135 lts. Tank Ø cm. 60x54h (included 1 Head end filler strip mod.TPA-9) • **DE** Indirekter Elektro-Kochkessel 135 lt. Becken Ø cm. 60x54h (inbegriffen 1 Abschluss-Element mod.TPA-9) • **FR** Marmite indirecte électrique 135 lt. Cuve Ø cm. 60x54h (inclus 1 Élément de jonction top mod.TPA-9) • **ES** Marmita de calefacción indirecta 135 lt. Cuba Ø cm. 60x54h (incluida 1 Chapa de cierre para top mod. TPA-9)

**cm. 80x 90x 90h**



⚡ 18 kW \_\_\_\_\_ **7.608,00**  
400V~3N \_\_\_\_\_ 110 / 1,07  
50/60 Hz \_\_\_\_\_

MOD. \_\_\_\_\_  
COD. \_\_\_\_\_

DESCRIZIONE/DESCRIPTION/BEZEICHNUNG/DESCRIPTION/DESCRIPCIÓN  
DIMENSIONI/DIMENSIONS/ABMESSUNGEN/DIMENSIONS/DIMENSIONES

POTENZA/POWER/LEISTUNG/PUISSANCE/POTENCIA  
VOLTAGGIO/VOLTAGE/SPANNUNG/VOLTAGE/VOLTAJE

⚡ kW \_\_\_\_\_  
kcal/h \_\_\_\_\_  
V~ \_\_\_\_\_  
Hz \_\_\_\_\_

PREZZO/PRICE € \_\_\_\_\_  
PREIS/PRIX/PRECIO € \_\_\_\_\_  
KG / M<sup>3</sup> \_\_\_\_\_

**PI150A-98ET PENTOLA INDIRETTA ELETTRICA LT. 135 VASCA  
Ø CM. 60X54H - CARICO AUTOMATICO**

0911A836

**INTERCAPEDINE (INCLUSA 1 TESTATA  
CHIUSURA PIANO MOD.TPA-9)**

**EN** Electric indirect boiling pan 135 lts. Tank Ø cm. 60x54h - automatic water-charge of double jacket (included 1 Head end filler strip mod.TPA-9) • **DE** Indirekter Elektro-Kochkessel 135 lt. Becken Ø cm. 60x54h - automatische Wasserstandskontrolle im Zwischenmantel (inbegriffen 1 Abschluss-Element mod. TPA-9) • **FR** Marmite indirecte électrique 135 lt. Cuve Ø cm. 60x54h - remplissage automatique dans la double paroi (inclus 1 Élément de jonction top mod.TPA-9) • **ES** Marmita de calefacción indirecta 135 lt. Cuba Ø cm. 60x54h - carga automática de la camisa intercambiador (incluida 1 Chapa de cierre para top mod.TPA-9)  
**cm. 80x 90x 90h**



⚡ 18 kW \_\_\_\_\_ **9.415,00**  
400V~3N \_\_\_\_\_ 110 / 1,07  
50/60 Hz \_\_\_\_\_

**PIA150-98ET PENTOLA INDIRETTA ELETTRICA LT. 135**

09110837

**AUTOCLAVE - VASCA CM. Ø 60X54H  
(INCLUSA 1 TESTATA CHIUSURA PIANO MOD.  
TPA-9)**

**EN** Electric indirect boiling pan 135 lts. - Autoclave Tank Ø cm. 60x54h (included 1 Head end filler strip mod.TPA-9) • **DE** Indirekter Elektro-Kochkessel 135 lt. - Druckkessel Becken Ø cm. 60x54h (inbegriffen 1 Abschluss-Element mod.TPA-9) • **FR** Marmite indirecte électrique 135 lt. - Autoclave Cuve Ø cm. 60x54h (inclus 1 Élément de jonction top mod.TPA-9) • **ES** Marmita de calefacción 135 lt. - Autoclave Cuba Ø cm. 60x54h (incluida 1 Chapa de cierre para top mod.TPA-9)  
**cm. 80x 90x 90h**

⚡ 18 kW \_\_\_\_\_ **8.943,00**  
400V~3N \_\_\_\_\_ 116 / 1,07  
50/60 Hz \_\_\_\_\_

**PIA150A-98ET PENTOLA INDIRETTA ELETTRICA LT. 135  
AUTOCLAVE - VASCA CM. Ø 60X54H - CARICO  
AUTOMATICO INTERCAPEDINE (INCLUSA 1  
TESTATA CHIUSURA PIANO MOD.TPA-9)**

0911A837

**EN** Electric indirect boiling pan 135 lts. - Autoclave Tank Ø cm. 60x54h - automatic water-charge of double jacket (included 1 Head end filler strip mod.TPA-9) • **DE** Indirekter Elektro-Kochkessel 135 lt. - Druckkessel Becken Ø cm. 60x54h - automatische Wasserstandskontrolle im Zwischenmantel (inbegriffen 1 Abschluss-Element mod.TPA-9) • **FR** Marmite indirecte électrique 135 lt. - Autoclave Cuve Ø cm. 60x54h - remplissage automatique dans la double paroi (inclus 1 Élément de jonction top mod.TPA-9) • **ES** Marmita de calefacción 135 lt. - Autoclave Cuba Ø cm. 60x54h - carga automática de la camisa intercambiador (incluida 1 Chapa de cierre para top mod.TPA-9)  
**cm. 80x 90x 90h**

⚡ 18 kW \_\_\_\_\_ **10.750,00**  
400V~3N \_\_\_\_\_ 116 / 1,07  
50/60 Hz \_\_\_\_\_

**PD150-98G PENTOLA DIRETTA GAS LT. 140 VASCA Ø CM.  
60X54H (INCLUSA 1 TESTATA CHIUSURA  
PIANO MOD.TPA-9)**

09280854

**EN** Gas direct boiling pan 140 lts. Tank Ø cm. 60x54h (included 1 Head end filler strip mod.TPA-9) • **DE** Direkter Gas-Kochkessel 140 lt. Becken Ø cm. 60x54h (inbegriffen 1 Abschluss-Element mod.TPA-9) • **FR** Marmite directe à gaz 140 lt. Cuve Ø cm. 60x54h (inclus 1 Élément de jonction top mod.TPA-9) • **ES** Marmita de calefacción directa lt. 140 Cuba Ø cm. 60x54h (incluida 1 Chapa de cierre para top mod. TPA-9)  
**cm. 80x 90x 90h**



⚡ 21 kW \_\_\_\_\_ **5.916,00**  
18.060 kcal/h \_\_\_\_\_ 108 / 1,07

MOD. \_\_\_\_\_  
COD. \_\_\_\_\_

DESCRIZIONE/DESCRIPTION/BEZEICHNUNG/DESCRIPTION/DESCRIPCIÓN  
DIMENSIONI/DIMENSIONS/ABMESSUNGEN/DIMENSIONS/DIMENSIONES

POTENZA/POWER/LEISTUNG/PUISSANCE/POTENCIA  
VOLTAGGIO/VOLTAGE/SPANNUNG/VOLTAGE/VOLTAJE

⚡ kW \_\_\_\_\_  
18.060 kcal/h

⚡ kW \_\_\_\_\_  
V~ \_\_\_\_\_  
Hz

PREZZO/PRICE € \_\_\_\_\_  
PREIS/PRIX/PRECIO € \_\_\_\_\_  
KG / M<sup>3</sup>

**PDA150-98G PENTOLA DIRETTA GAS LT. 140 AUTOCLAVE  
09280855 VASCA Ø CM. 60X54H (INCLUSA 1 TESTATA  
CHIUSURA PIANO MOD.TPA-9)**

**EN** Gas direct boiling pan 140 lts. - Autoclave Tank Ø cm. 60x54h (included 1 Head end filler strip mod.TPA-9)  
• **DE** Direkter Gas-Kochkessel 140 lt. - Druckkessel Becken Ø cm. 60x54h (inbegriffen 1 Abschluss-Element mod.TPA-9) • **FR** Marmite directe à gaz 140 lt. - Autoclave Cuve Ø cm. 60x54h (inclus 1 Élément de jonction top mod.TPA-9) • **ES** Marmita de calefacción directa lt. 140 - Autoclave Cuba Ø cm. 60x54h (incluida 1 Chapa de cierre para top mod.TPA-9)  
**cm. 80x 90x 90h**



⚡ 21 kW \_\_\_\_\_ **7.251,00**  
18.060 kcal/h 113 / 1,07

**PI150-98G PENTOLA INDIRETTA GAS LT. 135 VASCA Ø  
09280856 CM. 60X54H (INCLUSA 1 TESTATA CHIUSURA  
PIANO MOD.TPA-9)**

**EN** Gas indirect boiling pan 135 lts. Tank Ø cm. 60x54h (included 1 Head end filler strip mod.TPA-9)  
• **DE** Indirekter Gas-Kochkessel 135 lt. Becken Ø cm. 60x54h (inbegriffen 1 Abschluss-Element mod.TPA-9)  
• **FR** Marmite indirecte à gaz 135 lt. Cuve Ø cm. 60x54h (inclus 1 Élément de jonction top mod.TPA-9)  
• **ES** Marmita de calefacción Indirecta lt. 135 Cuba Ø cm. 60x54h (incluida 1 Chapa de cierre para top mod.TPA-9)  
**cm. 80x 90x 90h**



⚡ 21 kW \_\_\_\_\_ **7.810,00**  
18.060 kcal/h 135 / 1,07

**PI150A-98G PENTOLA INDIRETTA GAS LT. 135 VASCA  
0928A856 Ø CM. 60X54H - CARICO AUTOMATICO  
INTERCAPEDINE (INCLUSA 1 TESTATA  
CHIUSURA PIANO MOD.TPA-9)**

**EN** Gas indirect boiling pan 135 lts. Tank Ø cm. 60x54h - automatic water-charge of double jacket (included 1 Head end filler strip mod.TPA-9) • **DE** Indirekter Gas-Kochkessel 135 lt. Becken Ø cm. 60x54h - automatische Wasserstandskontrolle im Zwischenmantel (inbegriffen 1 Abschluss-Element mod.TPA-9) • **FR** Marmite indirecte à gaz 135 lt. Cuve Ø cm. 60x54h - remplissage automatique dans la double paroi (inclus 1 Élément de jonction top mod.TPA-9) • **ES** Marmita de calefacción Indirecta lt. 135 Cuba Ø cm. 60x54h - carga automática de la camisa intercambiador (incluida 1 Chapa de cierre para top mod.TPA-9)  
**cm. 80x 90x 90h**

⚡ 21 kW \_\_\_\_\_ **9.767,00**  
18.060 kcal/h 135 / 1,07

⚡ 0,1 KW \_\_\_\_\_  
230V~ \_\_\_\_\_  
50/60 Hz

**PIA150-98G PENTOLA INDIRETTA GAS LT. 135 AUTOCLAVE  
09280857 VASCA Ø CM. 60X54H (INCLUSA 1 TESTATA  
CHIUSURA PIANO MOD.TPA-9)**

**EN** Gas indirect boiling pan 135 lts. - Autoclave Tank Ø cm. 60x54h (included 1 Head end filler strip mod.TPA-9)  
• **DE** Indirekter Gas-Kochkessel 135 lt. - Druckkessel Becken Ø cm. 60x54h (inbegriffen 1 Abschluss-Element mod.TPA-9) • **FR** Marmite indirecte électrique à gaz 135 lt. - Autoclave Cuve Ø cm. 60x54h (inclus 1 Élément de jonction top mod.TPA-9) • **ES** Marmita de calefacción indirecta a gas 135 lt. - Autoclave Cuba Ø cm. 60x54h (incluida 1 Chapa de cierre para top mod.TPA-9)  
**cm. 80x 90x 90h**

⚡ 21 kW \_\_\_\_\_ **9.145,00**  
18.060 kcal/h 115 / 1,07

MOD. \_\_\_\_\_  
COD. \_\_\_\_\_

DESCRIZIONE/DESCRIPTION/BEZEICHNUNG/DESCRIPTION/DESCRIPCIÓN  
DIMENSIONI/DIMENSIONS/ABMESSUNGEN/DIMENSIONS/DIMENSIONES

POTENZA/POWER/LEISTUNG/PUISSANCE/POTENCIA  
VOLTAGGIO/VOLTAGE/SPANNUNG/VOLTAGE/VOLTAJE

⚡ kW \_\_\_\_\_  
kcal/h \_\_\_\_\_  
⚡ kW \_\_\_\_\_  
V~ \_\_\_\_\_  
Hz \_\_\_\_\_

PREZZO/PRICE € \_\_\_\_\_  
PREIS/PRIX/PRECIO € \_\_\_\_\_  
KG / M<sup>3</sup> \_\_\_\_\_

## PIA150A-98G PENTOLA INDIRETTA GAS LT. 135

0928A857

**AUTOCLAVE VASCA Ø CM. 60X54H - CARICO AUTOMATICO INTERCAPEDINE (INCLUSA 1 TESTATA CHIUSURA PIANO MOD.TPA-9)**

**EN** Gas indirect boiling pan 135 lts. - Autoclave Tank Ø cm. 60x54h - automatic water-charge of double jacket (included 1 Head end filler strip mod.TPA-9) • **DE** Indirekter Gas-Kochkessel 135 lt. - Druckkessel Becken Ø cm. 60x54h - automatische Wasserstandskontrolle im Zwischenmantel (inbegriffen 1 Abschluss-Element mod.TPA-9) • **FR** Marmite indirecte électrique à gaz 135 lt. - Autoclave Cuve Ø cm. 60x54h - remplissage automatique dans la double paroi (inclus 1 Élément de jonction top mod.TPA-9) • **ES** Marmita de calefacción indirecta a gas 135 lt. - Autoclave Cuba Ø cm. 60x54h - carga automática de la camisa intercambiador (incluida 1 Chapa de cierre para top mod.TPA-9)  
**cm. 80x 90x 90h**



⚡ 21 kW \_\_\_\_\_ **11.102,00**  
18.060 kcal/h \_\_\_\_\_ 115 / 1,07

⚡ 0,1 kW \_\_\_\_\_  
230V~ \_\_\_\_\_  
50/60 Hz \_\_\_\_\_

## FTL-94ET

09060431

**FRY-TOP ELETTRICO LISCIO, SU MOBILE A GIORNO, PIASTRA CM.36X68 (INCLUSA 1 TESTATA CHIUSURA PIANO MOD.TPA-9)**

**EN** Electric Fry-top smooth griddle, on open cabinet, plate cm.36x68 (included 1 Head end filler strip mod.TPA-9) • **DE** Griddleplatte elektrische glatt, mit offenem Unterbau, platte cm.36x68 (inbegriffen 1 Abschluss-Element mod.TPA-9) • **FR** Plaque électriques lisse, sur armoire ouvert, plaque cm.36x68 (inclus 1 Élément de jonction top mod.TPA-9) • **ES** Fry-top eléctrico liso, sobre mueble abierto, plancha cm.36x68 (incluida 1 Chapa de cierre para top mod.TPA-9)  
**cm. 40x 90x 90h**



⚡ 7,5 kW \_\_\_\_\_ **2.097,00**  
400V~3N \_\_\_\_\_ 79 / 0,46  
50/60 Hz \_\_\_\_\_

## FTL-94ETS

09060434

**FRY-TOP ELETTRICO LISCIO CROMATO SUPERCHROME (MOCA APPROVED), SU MOBILE A GIORNO, PIASTRA CM.36X68 (INCLUSA 1 TESTATA CHIUSURA PIANO MOD. TPA-9)**

**EN** Electric Fry-top smooth chromed griddle SUPERCHROME (Moca Approved), on open cabinet, plate cm.36x68 (included 1 Head end filler strip mod.TPA-9) • **DE** Griddleplatte elektrische glatt hartverchromt SUPERCHROME (Moca Approved), mit offenem Unterbau, platte cm.36x68 (inbegriffen 1 Abschluss-Element mod.TPA-9) • **FR** Plaque électriques lisse chromée SUPERCHROME (Moca Approved), sur armoire ouvert, plaque cm.36x68 (inclus 1 Élément de jonction top mod.TPA-9) • **ES** Fry-top eléctrico liso cromado SUPERCHROME (Moca Approved), sobre mueble abierto, plancha cm.36x68 (incluida 1 Chapa de cierre para top mod.TPA-9)  
**cm. 40x 90x 90h**

⚡ 7,5 kW \_\_\_\_\_ **2.487,00**  
400V~3N \_\_\_\_\_ 79 / 0,46  
50/60 Hz \_\_\_\_\_

## FTR-94ET

09060433

**FRY-TOP ELETTRICO RIGATO, SU MOBILE A GIORNO, PIASTRA CM.36X68 (INCLUSA 1 TESTATA CHIUSURA PIANO MOD.TPA-9)**

**EN** Electric Fry-top grooved griddle, on open cabinet, plate cm.36x68 (included 1 Head end filler strip mod.TPA-9) • **DE** Griddleplatte elektrische gerillt, mit offenem Unterbau, platte cm.36x68 (inbegriffen 1 Abschluss-Element mod.TPA-9) • **FR** Plaque électriques nervurée, sur armoire ouvert, plaque cm.36x68 (inclus 1 Élément de jonction top mod.TPA-9) • **ES** Fry-top eléctrico estriado, sobre mueble abierto, plancha cm.36x68 (incluida 1 Chapa de cierre para top mod.TPA-9)  
**cm. 40x 90x 90h**



⚡ 7,5 kW \_\_\_\_\_ **2.246,00**  
400V~3N \_\_\_\_\_ 79 / 0,46  
50/60 Hz \_\_\_\_\_



MOD. \_\_\_\_\_  
COD. \_\_\_\_\_

DESCRIZIONE/DESCRIPTION/BEZEICHNUNG/DESCRIPTION/DESCRIPCIÓN  
DIMENSIONI/DIMENSIONS/ABMESSUNGEN/DIMENSIONS/DIMENSIONES

POTENZA/POWER/LEISTUNG/PUISSANCE/POTENCIA  
VOLTAGGIO/VOLTAGE/SPANNUNG/VOLTAGE/VOLTAJE

⚡ kW kcal/h  
⚡ kW V~ Hz

PREZZO/PRICE €  
PREIS/PRIX/PRECIO €  
KG / M<sup>3</sup>

**FTR-94ETS**  
09060436

**FRY-TOP ELETTRICO RIGATO CROMATO SUPERCHROME (MOCA APPROVED), SU MOBILE A GIORNO, PIASTRA CM.36X68 (INCLUSA 1 TESTATA CHIUSURA PIANO MOD. TPA-9)**

**EN** Electric Fry-top grooved chromed griddle SUPERCHROME (Moca Approved), on open cabinet, plate cm.36x68 (included 1 Head end filler strip mod.TPA-9) • **DE** Griddleplatte elektrische gerillt hartverchromt SUPERCHROME (Moca Approved), mit offenem Unterbau, platte cm.36x68 (inbegriffen 1 Abschluss-Element mod.TPA-9) • **FR** Plaque électriques nervurée chromée SUPERCHROME (Moca Approved), sur armoire ouvert, plaque cm.36x68 (inclus 1 Élément de jonction top mod.TPA-9) • **ES** Fry-top eléctrico estriado cromado SUPERCHROME (Moca Approved), sobre mueble abierto, plancha cm.36x68 (incluida 1 Chapa de cierre para top mod.TPA-9)  
**cm. 40x 90x 90h**



⚡ 7,5 kW **2.631,00**  
400V~3N 79 / 0,46  
50/60 Hz



**FTR-98ET**  
09060831

**FRY-TOP ELETTRICO LISCIO, SU MOBILE A GIORNO, PIASTRA CM.76X68 - 2 ZONE DI COTTURA (INCLUSA 1 TESTATA CHIUSURA PIANO MOD.TPA-9)**

**EN** Electric Fry-top smooth griddle, on open cabinet, plate cm.76x68 - 2 cooking areas (included 1 Head end filler strip mod.TPA-9) • **DE** Griddleplatte elektrische glatt, mit offenem Unterbau, platte cm.76x68 - 2 Heizzonen (inbegriffen 1 Abschluss-Element mod.TPA-9) • **FR** Plaque électriques lisse, sur armoire ouvert, plaque cm.76x68 - 2 zones de cuisson (inclus 1 Élément de jonction top mod.TPA-9) • **ES** Fry-top eléctrico liso, sobre mueble abierto, plancha cm.76x68 - 2 zonas de cocción (incluida 1 Chapa de cierre para top mod.TPA-9)  
**cm. 80x 90x 90h**



⚡ 15 kW **3.051,00**  
400V~3N 126 / 0,89  
50/60 Hz

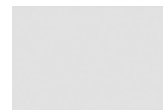

**FTL-98ETS**  
09060834

**FRY-TOP ELETTRICO LISCIO CROMATO SUPERCHROME (MOCA APPROVED), SU MOBILE A GIORNO, PIASTRA CM.76X68 - 2 ZONE DI COTTURA (INCLUSA 1 TESTATA CHIUSURA PIANO MOD.TPA-9)**

**EN** Electric Fry-top smooth chromed griddle SUPERCHROME (Moca Approved), on open cabinet, plate cm.76x68 - 2 cooking areas (included 1 Head end filler strip mod.TPA-9) • **DE** Griddleplatte elektrische glatt hartverchromt SUPERCHROME (Moca Approved), mit offenem Unterbau, platte cm.76x68 - 2 Heizzonen (inbegriffen 1 Abschluss-Element mod.TPA-9) • **FR** Plaque électriques lisse chromée SUPERCHROME (Moca Approved), sur armoire ouvert, plaque cm.76x68 - 2 zones de cuisson (inclus 1 Élément de jonction top mod.TPA-9) • **ES** Fry-top eléctrico liso cromado SUPERCHROME (Moca Approved), sobre mueble abierto, plancha cm.76x68 - 2 zonas de cocción (incluida 1 Chapa de cierre para top mod.TPA-9)  
**cm. 80x 90x 90h**

⚡ 15 kW **3.631,00**  
400V~3N 126 / 0,89  
50/60 Hz

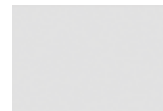

# FRY-TOP ELETTRICI

MOD. \_\_\_\_\_  
COD. \_\_\_\_\_

DESCRIZIONE/DESCRIPTION/BEZEICHNUNG/DESCRIPTION/DESCRIPCIÓN  
DIMENSIONI/DIMENSIONS/ABMESSUNGEN/DIMENSIONS/DIMENSIONES

POTENZA/POWER/LEISTUNG/PUISSANCE/POTENCIA  
VOLTAGGIO/VOLTAGE/SPANNUNG/VOLTAGE/VOLTAJE

⚡ kW kcal/h  
⚡ kW V~ Hz

PREZZO/PRICE €  
PREIS/PRIX/PRECIO €  
KG / M<sup>3</sup>

**FTLR-98ET**  
09060832

**FRY-TOP ELETTRICO 1/2 RIGATO + 1/2 LISCIO, SU MOBILE A GIORNO, PIASTRA CM.76X68 - 2 ZONE DI COTTURA (INCLUSA 1 TESTATA CHIUSURA PIANO MOD.TPA-9)**

**EN** Electric Fry-top 1/2 grooved + 1/2 smooth, on open cabinet, plate cm.76x68 - 2 cooking areas (included 1 Head end filler strip mod.TPA-9) • **DE** Griddleplatte elektrische 1/2 gerillt + 1/2 glatt, mit offenem Unterbau, platte cm.76x68 - 2 Heizzonen (inbegriffen 1 Abschluss-Element mod.TPA-9) • **FR** Plaque électriques 1/2 nervurée + 1/2 lisse, sur armoire ouvert, plaque cm.76x68 - 2 zones de cuisson (inclus 1 Élément de jonction top mod.TPA-9) • **ES** Fry-top eléctrico 1/2 estriado + 1/2 liso, sobre mueble abierto, plancha cm.76x68 - 2 zonas de cocción (incluida 1 Chapa de cierre para top mod.TPA-9)

**cm. 80x 90x 90h**



⚡ 15 kW **3.230,00**  
400V~3N 126 / 0,89  
50/60 Hz



**FTLR-98ETS**  
09060835

**FRY-TOP ELETTRICO 1/2 RIGATO + 1/2 LISCIO CROMATO SUPERCHROME (MOCA APPROVED), SU MOBILE A GIORNO, PIASTRA CM.76X68 - 2 ZONE DI COTTURA (INCLUSA 1 TESTATA CHIUSURA PIANO MOD.TPA-9)**

**EN** Electric Fry-top 1/2 grooved + 1/2 smooth chromed griddle SUPERCHROME (Moca Approved), on open cabinet, plate cm.76x68 - 2 cooking areas (included 1 Head end filler strip mod.TPA-9) • **DE** Griddleplatte elektrische 1/2 gerillt + 1/2 glatt hartverchromt SUPERCHROME (Moca Approved), mit offenem Unterbau, platte cm.76x68 - 2 Heizzonen (inbegriffen 1 Abschluss-Element mod.TPA-9) • **FR** Plaque électriques 1/2 nervurée + 1/2 lisse chromée SUPERCHROME (Moca Approved), sur armoire ouvert, plaque cm.76x68 - 2 zones de cuisson (inclus 1 Élément de jonction top mod.TPA-9) • **ES** Fry-top eléctrico 1/2 estriado + 1/2 liso cromado SUPERCHROME (Moca Approved), sobre mueble abierto, plancha cm.76x68 - 2 zonas de cocción (incluida 1 Chapa de cierre para top mod.TPA-9)

**cm. 80x 90x 90h**

⚡ 15 kW **3.806,00**  
400V~3N 126 / 0,89  
50/60 Hz



**FTR-98ET**  
09060833

**FRY-TOP ELETTRICO RIGATO, SU MOBILE A GIORNO, PIASTRA CM.76X68 - 2 ZONE DI COTTURA (INCLUSA 1 TESTATA CHIUSURA PIANO MOD.TPA-9)**

**EN** Electric Fry-top grooved griddle, on open cabinet, plate cm.76x68 - 2 cooking areas (included 1 Head end filler strip mod.TPA-9) • **DE** Griddleplatte elektrische gerillt, mit offenem Unterbau, platte cm.76x68 - 2 Heizzonen (inbegriffen 1 Abschluss-Element mod.TPA-9) • **FR** Plaque électriques nervurée, sur armoire ouvert, plaque cm.76x68 - 2 zones de cuisson (inclus 1 Élément de jonction top mod.TPA-9) • **ES** Fry-top eléctrico estriado, sobre mueble abierto, plancha cm.76x68 - 2 zonas de cocción (incluida 1 Chapa de cierre para top mod.TPA-9)

**cm. 80x 90x 90h**



⚡ 15 kW **3.407,00**  
400V~3N 126 / 0,89  
50/60 Hz



MOD. \_\_\_\_\_  
COD. \_\_\_\_\_

DESCRIZIONE/DESCRIPTION/BEZEICHNUNG/DESCRIPTION/DESCRIPCIÓN  
DIMENSIONI/DIMENSIONS/ABMESSUNGEN/DIMENSIONS/DIMENSIONES

POTENZA/POWER/LEISTUNG/PUISSANCE/POTENCIA  
VOLTAGGIO/VOLTAGE/SPANNUNG/VOLTAGE/VOLTAJE

⚡ kcal/h  
kW  
V~  
Hz

PREZZO/PRICE €  
PREIS/PRIX/PRECIO €  
KG / M<sup>3</sup>

**FTR-98ETS**  
09060836

**FRY-TOP ELETTRICO RIGATO CROMATO SUPERCHROME (MOCA APPROVED), SU MOBILE A GIORNO, PIASTRA CM.76X68 - 2 ZONE DI COTTURA (INCLUSA 1 TESTATA CHIUSURA PIANO MOD.TPA-9)**

**EN** Electric Fry-top grooved chromed griddle SUPERCHROME (Moca Approved), on open cabinet, plate cm.76x68 - 2 cooking areas (included 1 Head end filler strip mod.TPA-9) • **DE** Griddleplatte elektrische gerillt hartverchromt SUPERCHROME (Moca Approved), mit offenem Unterbau, platte cm.76x68 - 2 Heizzonen (inbegriffen 1 Abschluss-Element mod.TPA-9) • **FR** Plaque électriques nervurée chromée SUPERCHROME (Moca Approved), sur armoire ouvert, plaque cm.76x68 - 2 zones de cuisson (inclus 1 Élément de jonction top mod.TPA-9) • **ES** Fry-top eléctrico estriado cromado SUPERCHROME (Moca Approved), sobre mueble abierto, plancha cm.76x68 - 2 zonas de cocción (incluida 1 Chapa de cierre para top mod.TPA-9)  
**cm. 80x 90x 90h**



⚡ 15 kW  
400V~3N  
50/60 Hz

**3.982,00**  
126 / 0,89



**FTL-912ET**  
0906123B

**FRY-TOP ELETTRICO LISCIO, SU MOBILE A GIORNO, PIASTRA CM.110,5X65 - 3 ZONE DI COTTURA (INCLUSA 1 TESTATA CHIUSURA PIANO MOD.TPA-9)**

**EN** Electric Fry-top smooth griddle, on open cabinet, plate cm.110,5x65 - 3 cooking areas (included 1 Head end filler strip mod.TPA-9) • **DE** Griddleplatte elektrische glatt, mit offenem Unterbau, platte cm.110,5x65 - 3 Heizzonen (inbegriffen 1 Abschluss-Element mod.TPA-9) • **FR** Plaque électriques lisse, sur armoire ouvert, plaque cm.110,5x65 - 3 zones de cuisson (inclus 1 Élément de jonction top mod.TPA-9) • **ES** Fry-top eléctrico liso, sobre mueble abierto, plancha cm.110,5x65 - 3 zonas de cocción (incluida 1 Chapa de cierre para top mod.TPA-9)  
**cm. 120x 90x 90h**



⚡ 22,5 kW  
400V~3N  
50/60 Hz

**4.608,00**  
186 / 1,34

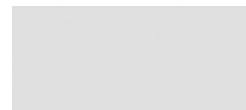

**FTL-912ETS**  
0906123E

**FRY-TOP ELETTRICO LISCIO CROMATO SUPERCHROME (MOCA APPROVED), SU MOBILE A GIORNO, PIASTRA CM.110,5X65 - 3 ZONE DI COTTURA (INCLUSA 1 TESTATA CHIUSURA PIANO MOD.TPA-9)**

**EN** Electric Fry-top smooth chromed griddle SUPERCHROME (Moca Approved), on open cabinet, plate cm.110,5x65 - 3 cooking areas (included 1 Head end filler strip mod.TPA-9) • **DE** Griddleplatte elektrische glatt hartverchromt SUPERCHROME (Moca Approved), mit offenem Unterbau, platte cm.110,5x65 - 3 Heizzonen (inbegriffen 1 Abschluss-Element mod.TPA-9) • **FR** Plaque électriques lisse chromée SUPERCHROME (Moca Approved), sur armoire ouvert, plaque cm.110,5x65 - 3 zones de cuisson (inclus 1 Élément de jonction top mod.TPA-9) • **ES** Fry-top eléctrico liso cromado SUPERCHROME (Moca Approved), sobre mueble abierto, plancha cm.110,5x65 - 3 zonas de cocción (incluida 1 Chapa de cierre para top mod.TPA-9)  
**cm. 120x 90x 90h**

⚡ 22,5 kW  
400V~3N  
50/60 Hz

**5.307,00**  
186 / 1,34



# FRY-TOP ELETTRICI

MOD. \_\_\_\_\_  
COD. \_\_\_\_\_

DESCRIZIONE/DESCRIPTION/BEZEICHNUNG/DESCRIPTION/DESCRIPCIÓN  
DIMENSIONI/DIMENSIONS/ABMESSUNGEN/DIMENSIONS/DIMENSIONES

POTENZA/POWER/LEISTUNG/PUISSANCE/POTENCIA  
VOLTAGGIO/VOLTAGE/SPANNUNG/VOLTAGE/VOLTAJE

⚡ kW kcal/h  
⚡ kW  
V~ Hz

PREZZO/PRICE €  
PREIS/PRIX/PRECIO €  
KG / M<sup>3</sup>

**FTLR-912ET**  
0906123C

**FRY-TOP ELETTRICO 1/3 RIGATO + 2/3 LISCIO, SU MOBILE A GIORNO, PIASTRA CM.110,5X65 - 3 ZONE DI COTTURA (INCLUSA 1 TESTATA CHIUSURA PIANO MOD. TPA-9)**

**EN** Electric Fry-top 1/3 grooved + 2/3 smooth, on open cabinet, plate cm.110,5x65 - 3 cooking areas (included 1 Head end filler strip mod.TPA-9) • **DE** Griddleplatte elektrische 1/3 gerillt + 2/3 glatt, mit offenem Unterbau, platte cm.110,5x65 - 3 Heizzonen (inbegriffen 1 Abschluss-Element mod.TPA-9) • **FR** Plaque électriques 1/3 nervurée + 2/3 lisse, sur armoire ouvert, plaque cm.110,5x65 - 3 zones de cuisson (inclus 1 Élément de jonction top mod.TPA-9) • **ES** Fry-top eléctrico 1/3 estriado + 2/3 liso, sobre mueble abierto, plancha cm.110,5x65 - 3 zonas de cocción (incluida 1 Chapa de cierre para top mod.TPA-9)  
**cm. 120x 90x 90h**



⚡ 22,5 kW 4.904,00  
400V~3N 186 / 1,34  
50/60 Hz



**FTLR-912ETS**  
0906123F

**FRY-TOP ELETTRICO 1/3 RIGATO + 2/3 LISCIO CROMATO SUPERCHROME (MOCA APPROVED), SU MOBILE A GIORNO, PIASTRA CM.110,5X65 - 3 ZONE DI COTTURA (INCLUSA 1 TESTATA CHIUSURA PIANO MOD. TPA-9)**

**EN** Electric Fry-top 1/3 grooved + 2/3 smooth chromed griddle SUPERCHROME (Moca Approved), on open cabinet, plate cm.110,5x65 - 3 cooking areas (included 1 Head end filler strip mod.TPA-9) • **DE** Griddleplatte elektrische 1/3 gerillt + 2/3 glatt hartverchromt SUPERCHROME (Moca Approved), mit offenem Unterbau, platte cm.110,5x65 - 3 Heizzonen (inbegriffen 1 Abschluss-Element mod.TPA-9) • **FR** Plaque électriques 1/3 nervurée + 2/3 lisse chromée SUPERCHROME (Moca Approved), sur armoire ouvert, plaque cm.110,5x65 - 3 zones de cuisson (inclus 1 Élément de jonction top mod.TPA-9) • **ES** Fry-top eléctrico 1/3 estriado + 2/3 liso cromado SUPERCHROME (Moca Approved), sobre mueble abierto, plancha cm.110,5x65 - 3 zonas de cocción (incluida 1 Chapa de cierre para top mod.TPA-9)  
**cm. 120x 90x 90h**

⚡ 22,5 kW 5.600,00  
400V~3N 186 / 1,34  
50/60 Hz



**FTL-916ET**  
09061631

**FRY-TOP ELETTRICO LISCIO, SU MOBILE A GIORNO, PIASTRA CM.150,5X65 - 4 ZONE DI COTTURA (INCLUSA 1 TESTATA CHIUSURA PIANO MOD.TPA-9)**

**EN** Electric Fry-top smooth griddle, on open cabinet, plate cm.150,5x65 - 4 cooking areas (included 1 Head end filler strip mod.TPA-9) • **DE** Griddleplatte elektrische glatt, mit offenem Unterbau, platte cm.150,5x65 - 4 Heizzonen (inbegriffen 1 Abschluss-Element mod.TPA-9) • **FR** Plaque électriques lisse, sur armoire ouvert, plaque cm.150,5x65 - 4 zones de cuisson (inclus 1 Élément de jonction top mod.TPA-9) • **ES** Fry-top eléctrico liso, sobre mueble abierto, plancha cm.150,5x65 - 4 zonas de cocción (incluida 1 Chapa de cierre para top mod.TPA-9)  
**cm. 160x 90x 90h**



⚡ 30 kW 6.216,00  
400V~3N 256 / 1,96  
50/60 Hz

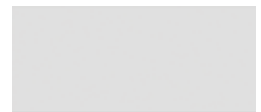

MOD. \_\_\_\_\_  
COD. \_\_\_\_\_

DESCRIZIONE/DESCRIPTION/BEZEICHNUNG/DESCRIPTION/DESCRIPCIÓN  
DIMENSIONI/DIMENSIONS/ABMESSUNGEN/DIMENSIONS/DIMENSIONES

POTENZA/POWER/LEISTUNG/PUISSANCE/POTENCIA  
VOLTAGGIO/VOLTAGE/SPANNUNG/VOLTAGE/VOLTAJE

⚡ kW  
kcal/h

⚡ kW  
V~  
Hz

PREZZO/PRICE €  
PREIS/PRIX/PRECIO €  
KG / M<sup>3</sup>

**FTL-916ETS**  
09061634

**FRY-TOP ELETTRICO LISCIO CROMATO SUPERCHROME (MOCA APPROVED), SU MOBILE A GIORNO, PIASTRA CM.150,5X65 - 4 ZONE DI COTTURA (INCLUSA 1 TESTATA CHIUSURA PIANO MOD.TPA-9)**

**EN** Electric Fry-top smooth chromed griddle SUPERCHROME (Moca Approved), on open cabinet, plate cm.150,5x65 - 4 cooking areas (included 1 Head end filler strip mod.TPA-9) • **DE** Griddleplatte elektrische glatt hartverchromt SUPERCHROME (Moca Approved), mit offenem Unterbau, platte cm.150,5x65 - 4 Heizzonen (inbegriffen 1 Abschluss-Element mod.TPA-9) • **FR** Plaque électriques lisse chromée SUPERCHROME (Moca Approved), sur armoire ouvert, plaque cm.150,5x65 - 4 zones de cuisson (inclus 1 Élément de jonction top mod.TPA-9) • **ES** Fry-top eléctrico liso cromado SUPERCHROME (Moca Approved), sobre mueble abierto, plancha cm.150,5x65 - 4 zonas de cocción (incluida 1 Chapa de cierre para top mod.TPA-9)  
**cm. 160x 90x 90h**



⚡ 30 kW  
400V~3N  
50/60 Hz

**7.090,00**  
256 / 1,96

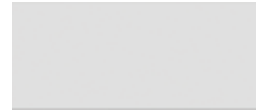

**FTL-94G**  
09230451

**FRY-TOP GAS LISCIO, SU MOBILE A GIORNO, PIASTRA CM.36X68 (INCLUSA 1 TESTATA CHIUSURA PIANO MOD.TPA-9)**

**EN** Gas Fry-top smooth griddle, on open cabinet, plate cm.36x68 (included 1 Head end filler strip mod.TPA-9) • **DE** Gas-griddleplatte glatt, mit offenem Unterbau, platte cm.36x68 (inbegriffen 1 Abschluss-Element mod.TPA-9) • **FR** Plaque gaz lisse, sur armoire ouvert, plaque cm.36x68 (inclus 1 Élément de jonction top mod.TPA-9) • **ES** Fry-top gas liso, sobre mueble abierto, plancha cm.36x68 (incluida 1 Chapa de cierre para top mod.TPA-9)  
**cm. 40x 90x 90h**



⚡ 9 kW  
7.740 kcal/h

**2.065,00**  
81 / 0,46



**FTL-94GS**  
09230454

**FRY-TOP GAS LISCIO CROMATO SUPERCHROME (MOCA APPROVED), SU MOBILE A GIORNO, PIASTRA CM.36X68 (INCLUSA 1 TESTATA CHIUSURA PIANO MOD.TPA-9)**

**EN** Gas Fry-top smooth chromed griddle SUPERCHROME (Moca Approved), on open cabinet, plate cm.36x68 (included 1 Head end filler strip mod.TPA-9) • **DE** Gas-griddleplatte glatt hartverchromt SUPERCHROME (Moca Approved), mit offenem Unterbau, platte cm.36x68 (inbegriffen 1 Abschluss-Element mod.TPA-9) • **FR** Plaque gaz lisse chromée SUPERCHROME (Moca Approved), sur armoire ouvert, plaque cm.36x68 (inclus 1 Élément de jonction top mod.TPA-9) • **ES** Fry-top gas liso cromado SUPERCHROME (Moca Approved), sobre mueble abierto, plancha cm.36x68 (incluida 1 Chapa de cierre para top mod.TPA-9)  
**cm. 40x 90x 90h**

⚡ 9 kW  
7.740 kcal/h

**2.476,00**  
81 / 0,46



**FTL-94G**  
09230453

**FRY-TOP GAS RIGATO, SU MOBILE A GIORNO, PIASTRA CM.36X68 (INCLUSA 1 TESTATA CHIUSURA PIANO MOD.TPA-9)**

**EN** Gas Fry-top grooved griddle, on open cabinet, plate cm.36x68 (included 1 Head end filler strip mod.TPA-9) • **DE** Gas-griddleplatte gerillt, mit offenem Unterbau, platte cm.36x68 (inbegriffen 1 Abschluss-Element mod.TPA-9) • **FR** Plaque gaz nervurée, sur armoire ouvert, plaque cm.36x68 (inclus 1 Élément de jonction top mod.TPA-9) • **ES** Fry-top gas estriado, sobre mueble abierto, plancha cm.36x68 (incluida 1 Chapa de cierre para top mod.TPA-9)  
**cm. 40x 90x 90h**



⚡ 9 kW  
7.740 kcal/h

**2.210,00**  
81 / 0,46





MOD. \_\_\_\_\_  
COD. \_\_\_\_\_

DESCRIZIONE/DESCRIPTION/BEZEICHNUNG/DESCRIPTION/DESCRIPCIÓN  
DIMENSIONI/DIMENSIONS/ABMESSUNGEN/DIMENSIONS/DIMENSIONES

POTENZA/POWER/LEISTUNG/PUISSANCE/POTENCIA  
VOLTAGGIO/VOLTAGE/SPANNUNG/VOLTAGE/VOLTAJE

⚡ kW  
kcal/h

⚡ kW  
V~  
Hz

PREZZO/PRICE €  
PREIS/PRIX/PRECIO €  
KG / M<sup>3</sup>

**FTR-94GS**  
09230456

**FRY-TOP GAS RIGATO CROMATO SUPERCHROME (MOCA APPROVED), SU MOBILE A GIORNO, PIASTRA CM.36X68 (INCLUSA 1 TESTATA CHIUSURA PIANO MOD. TPA-9)**

**EN** Gas Fry-top grooved chromed griddle SUPERCHROME (Moca Approved), on open cabinet, plate cm.36x68 (included 1 Head end filler strip mod. TPA-9) • **DE** Gas-griddleplatte gerillt hartverchromt SUPERCHROME (Moca Approved), mit offenem Unterbau, platte cm.36x68 (inbegriffen 1 Abschluss-Element mod.TPA-9) • **FR** Plaque gaz nervurée chromée SUPERCHROME (Moca Approved), sur armoire ouvert, plaque cm.36x68 (inclus 1 Élément de jonction top mod.TPA-9) • **ES** Fry-top gas estriado cromado SUPERCHROME (Moca Approved), sobre mueble abierto, plancha cm.36x68 (incluida 1 Chapa de cierre para top mod.TPA-9)  
**cm. 40x 90x 90h**



⚡ 9 kW  
7.740 kcal/h

**2.622,00**  
81 / 0,46



**FTL-98G**  
09230851

**FRY-TOP GAS LISCIO, SU MOBILE A GIORNO, PIASTRA CM.76X68 - 2 ZONE DI COTTURA (INCLUSA 1 TESTATA CHIUSURA PIANO MOD. TPA-9)**

**EN** Gas Fry-top smooth griddle, on open cabinet, plate cm.76x68 - 2 cooking areas (included 1 Head end filler strip mod.TPA-9) • **DE** Gas-griddleplatte glatt, mit offenem Unterbau, platte cm.76x68 - 2 Heizzonen (inbegriffen 1 Abschluss-Element mod.TPA-9) • **FR** Plaque gaz lisse, sur armoire ouvert, plaque cm.76x68 - 2 zones de cuisson (inclus 1 Élément de jonction top mod.TPA-9) • **ES** Fry-top gas liso, sobre mueble abierto, plancha cm.76x68 - 2 zonas de cocción (incluida 1 Chapa de cierre para top mod.TPA-9)  
**cm. 80x 90x 90h**



⚡ 18 kW  
15.480 kcal/h

**3.158,00**  
134 / 0,89

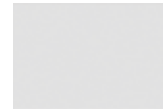

**FTL-98GS**  
09230854

**FRY-TOP GAS LISCIO CROMATO SUPERCHROME (MOCA APPROVED), SU MOBILE A GIORNO, PIASTRA CM.76X68 - 2 ZONE DI COTTURA (INCLUSA 1 TESTATA CHIUSURA PIANO MOD.TPA-9)**

**EN** Gas Fry-top smooth chromed griddle SUPERCHROME (Moca Approved), on open cabinet, plate cm.76x68 - 2 cooking areas (included 1 Head end filler strip mod.TPA-9) • **DE** Gas-griddleplatte glatt hartverchromt SUPERCHROME (Moca Approved), mit offenem Unterbau, platte cm.76x68 - 2 Heizzonen (inbegriffen 1 Abschluss-Element mod.TPA-9) • **FR** Plaque gaz lisse chromée SUPERCHROME (Moca Approved), sur armoire ouvert, plaque cm.76x68 - 2 zones de cuisson (inclus 1 Élément de jonction top mod. TPA-9) • **ES** Fry-top gas liso cromado SUPERCHROME (Moca Approved), sobre mueble abierto, plancha cm.76x68 - 2 zonas de cocción (incluida 1 Chapa de cierre para top mod.TPA-9)  
**cm. 80x 90x 90h**

⚡ 18 kW  
15.480 kcal/h

**3.882,00**  
134 / 0,89

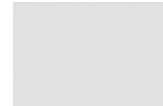

**FTLR-98G**  
09230852

**FRY-TOP GAS 1/2 RIGATO + 1/2 LISCIO, SU MOBILE A GIORNO, PIASTRA CM.76X68 - 2 ZONE DI COTTURA (INCLUSA 1 TESTATA CHIUSURA PIANO MOD.TPA-9)**

**EN** Gas Fry-top 1/2 grooved + 1/2 smooth, on open cabinet, plate cm.76x68 - 2 cooking areas (included 1 Head end filler strip mod.TPA-9) • **DE** Gas-griddleplatte 1/2 gerillt + 1/2 glatt, mit offenem Unterbau, platte cm.76x68 - 2 Heizzonen (inbegriffen 1 Abschluss-Element mod.TPA-9) • **FR** Plaque gaz 1/2 nervurée + 1/2 lisse, sur armoire ouvert, plaque cm.76x68 - 2 zones de cuisson (inclus 1 Élément de jonction top mod. TPA-9) • **ES** Fry-top gas 1/2 estriado + 1/2 liso, sobre mueble abierto, plancha cm.76x68 - 2 zonas de cocción (incluida 1 Chapa de cierre para top mod.TPA-9)  
**cm. 80x 90x 90h**



⚡ 18 kW  
15.480 kcal/h

**3.305,00**  
134 / 0,89



MOD. \_\_\_\_\_  
COD. \_\_\_\_\_

DESCRIZIONE/DESCRIPTION/BEZEICHNUNG/DESCRIPTION/DESCRIPCIÓN  
DIMENSIONI/DIMENSIONS/ABMESSUNGEN/DIMENSIONS/DIMENSIONES

POTENZA/POWER/LEISTUNG/PUISSANCE/POTENCIA  
VOLTAGGIO/VOLTAGE/SPANNUNG/VOLTAGE/VOLTAJE

18 kW  
15.480 kcal/h

PREZZO/PRICE €  
134 / 0,89  
KG / M<sup>3</sup>

**FTLR-98GS**  
09230855

**FRY-TOP GAS 1/2 RIGATO + 1/2 LISCIO CROMATO SUPERCHROME (MOCA APPROVED), SU MOBILE A GIORNO, PIASTRA CM.76X68 - 2 ZONE DI COTTURA (INCLUSA 1 TESTATA CHIUSURA PIANO MOD.TPA-9)**

**EN** Gas Fry-top 1/2 grooved + 1/2 smooth chromed griddle SUPERCHROME (Moca Approved), on open cabinet, plate cm.76x68 - 2 cooking areas (included 1 Head end filler strip mod.TPA-9) • **DE** Gas-griddleplatte 1/2 gerillt + 1/2 glatt hartverchromt SUPERCHROME (Moca Approved), mit offenem Unterbau, platte cm.76x68 - 2 Heizzonen (inbegriffen 1 Abschluss-Element mod.TPA-9) • **FR** Plaque gaz 1/2 nervurée + 1/2 lisse chromée SUPERCHROME (Moca Approved), sur armoire ouvert, plaque cm.76x68 - 2 zones de cuisson (inclus 1 Élément de jonction top mod.TPA-9) • **ES** Fry-top gas 1/2 estriado + 1/2 liso cromado SUPERCHROME (Moca Approved), sobre mueble abierto, plancha cm.76x68 - 2 zonas de cocción (incluida 1 Chapa de cierre para top mod.TPA-9)  
**cm. 80x 90x 90h**



18 kW  
15.480 kcal/h

**4.063,00**  
134 / 0,89



**FTR-98G**  
09230853

**FRY-TOP GAS RIGATO, SU MOBILE A GIORNO, PIASTRA CM.76X68 - 2 ZONE DI COTTURA (INCLUSA 1 TESTATA CHIUSURA PIANO MOD.TPA-9)**

**EN** Gas Fry-top grooved griddle, on open cabinet, plate cm.76x68 - 2 cooking areas (included 1 Head end filler strip mod.TPA-9) • **DE** Gas-griddleplatte gerillt, mit offenem Unterbau, platte cm.76x68 - 2 Heizzonen (inbegriffen 1 Abschluss-Element mod.TPA-9) • **FR** Plaque gaz nervurée, sur armoire ouvert, plaque cm.76x68 - 2 zones de cuisson (inclus 1 Élément de jonction top mod.TPA-9) • **ES** Fry-top gas estriado, sobre mueble abierto, plancha cm.76x68 - 2 zonas de cocción (incluida 1 Chapa de cierre para top mod.TPA-9)  
**cm. 80x 90x 90h**



18 kW  
15.480 kcal/h

**3.459,00**  
134 / 0,89



**FTR-98GS**  
09230856

**FRY-TOP GAS RIGATO CROMATO SUPERCHROME (MOCA APPROVED), SU MOBILE A GIORNO, PIASTRA CM.76X68 - 2 ZONE DI COTTURA (INCLUSA 1 TESTATA CHIUSURA PIANO MOD.TPA-9)**

**EN** Gas Fry-top grooved chromed griddle SUPERCHROME (Moca Approved), on open cabinet, plate cm.76x68 - 2 cooking areas (included 1 Head end filler strip mod.TPA-9) • **DE** Gas-griddleplatte gerillt hartverchromt SUPERCHROME (Moca Approved), mit offenem Unterbau, platte cm.76x68 - 2 Heizzonen (inbegriffen 1 Abschluss-Element mod.TPA-9) • **FR** Plaque gaz nervurée chromée SUPERCHROME (Moca Approved), sur armoire ouvert, plaque cm.76x68 - 2 zones de cuisson (inclus 1 Élément de jonction top mod.TPA-9) • **ES** Fry-top gas estriado cromado SUPERCHROME (Moca Approved), sobre mueble abierto, plancha cm.76x68 - 2 zonas de cocción (incluida 1 Chapa de cierre para top mod.TPA-9)  
**cm. 80x 90x 90h**

18 kW  
15.480 kcal/h

**4.245,00**  
134 / 0,89



MOD. \_\_\_\_\_  
COD. \_\_\_\_\_

DESCRIZIONE/DESCRIPTION/BEZEICHNUNG/DESCRIPTION/DESCRIPCIÓN  
DIMENSIONI/DIMENSIONS/ABMESSUNGEN/DIMENSIONS/DIMENSIONES

POTENZA/POWER/LEISTUNG/PUISSANCE/POTENCIA  
VOLTAGGIO/VOLTAGE/SPANNUNG/VOLTAGE/VOLTAJE

27 kW  
23.220 kcal/h

PREZZO/PRICE €  
PREIS/PRIX/PRECIO €  
KG / M<sup>3</sup>

**FTL-912G**  
0923125B

**FRY-TOP GAS LISCIO, SU MOBILE A GIORNO, PIASTRA CM.110,5X65 - 3 ZONE DI COTTURA (INCLUSA 1 TESTATA CHIUSURA PIANO MOD. TPA-9)**

**EN** Gas Fry-top smooth griddle, on open cabinet, plate cm.110,5x65 - 3 cooking areas (included 1 Head end filler strip mod.TPA-9) • **DE** Gas-griddleplatte glatt, mit offenem Unterbau, platte cm.110,5x65 - 3 Heizzonen (inbegriffen 1 Abschluss-Element mod.TPA-9) • **FR** Plaque gaz lisse, sur armoire ouvert, plaque cm.110,5x65 - 3 zones de cuisson (inclus 1 Élément de jonction top mod.TPA-9) • **ES** Fry-top gas liso, sobre mueble abierto, plancha cm.110,5x65 - 3 zonas de cocción (incluida 1 Chapa de cierre para top mod. TPA-9)

**cm. 120x 90x 90h**



27 kW  
23.220 kcal/h

**4.981,00**  
198 / 1,34

**FTL-912GS**  
0923125E

**FRY-TOP GAS LISCIO CROMATO SUPERCHROME (MOCA APPROVED), SU MOBILE A GIORNO, PIASTRA CM.110,5X65 - 3 ZONE DI COTTURA (INCLUSA 1 TESTATA CHIUSURA PIANO MOD.TPA-9)**

**EN** Gas Fry-top smooth chromed griddle SUPERCHROME (Moca Approved), on open cabinet, plate cm.110,5x65 - 3 cooking areas (included 1 Head end filler strip mod.TPA-9) • **DE** Gas-griddleplatte glatt hartverchromt SUPERCHROME (Moca Approved), mit offenem Unterbau, platte cm.110,5x65 - 3 Heizzonen (inbegriffen 1 Abschluss-Element mod.TPA-9) • **FR** Plaque gaz lisse chromée SUPERCHROME (Moca Approved), sur armoire ouvert, plaque cm.110,5x65 - 3 zones de cuisson (inclus 1 Élément de jonction top mod. TPA-9) • **ES** Fry-top gas liso cromado SUPERCHROME (Moca Approved), sobre mueble abierto, plancha cm.110,5x65 - 3 zonas de cocción (incluida 1 Chapa de cierre para top mod.TPA-9)

**cm. 120x 90x 90h**

27 kW  
23.220 kcal/h

**5.677,00**  
198 / 1,34

**FTLR-912G**  
0923125C

**FRY-TOP GAS 1/3 RIGATO + 2/3 LISCIO, SU MOBILE A GIORNO, PIASTRA CM.110,5X65 - 3 ZONE DI COTTURA (INCLUSA 1 TESTATA CHIUSURA PIANO MOD.TPA-9)**

**EN** Gas Fry-top 1/3 grooved + 2/3 smooth, on open cabinet, plate cm.110,5x65 - 3 cooking areas (included 1 Head end filler strip mod.TPA-9) • **DE** Gas-griddleplatte 1/3 gerillt + 2/3 glatt, mit offenem Unterbau, platte cm.110,5x65 - 3 Heizzonen (inbegriffen 1 Abschluss-Element mod.TPA-9) • **FR** Plaque gaz 1/3 nervurée + 2/3 lisse, sur armoire ouvert, plaque cm.110,5x65 - 3 zones de cuisson (inclus 1 Élément de jonction top mod.TPA-9) • **ES** Fry-top gas 1/3 estriado + 2/3 liso, sobre mueble abierto, plancha cm.110,5x65 - 3 zonas de cocción (incluida 1 Chapa de cierre para top mod.TPA-9)

**cm. 120x 90x 90h**



27 kW  
23.220 kcal/h

**5.275,00**  
198 / 1,34

MOD. \_\_\_\_\_  
COD. \_\_\_\_\_

DESCRIZIONE/DESCRIPTION/BEZEICHNUNG/DESCRIPTION/DESCRIPCIÓN  
DIMENSIONI/DIMENSIONS/ABMESSUNGEN/DIMENSIONS/DIMENSIONES

POTENZA/POWER/LEISTUNG/PUISSANCE/POTENCIA  
VOLTAGGIO/VOLTAGE/SPANNUNG/VOLTAGE/VOLTAJE

⚡ kW  
kcal/h

⚡ kW  
V~  
Hz

PREZZO/PRICE €  
PREIS/PRIX/PRECIO €  
KG / M<sup>3</sup>

**FTLR-912GS FRY-TOP GAS 1/3 RIGATO + 2/3 LISCIO CROMATO SUPERCHROME (MOCA APPROVED), SU MOBILE A GIORNO, PIASTRA CM.110,5X65 - 3 ZONE DI COTTURA (INCLUSA 1 TESTATA CHIUSURA PIANO MOD. TPA-9)**

0923125F

**EN** Gas Fry-top 1/3 grooved + 2/3 smooth chromed SUPERCHROME (Moca Approved), on open cabinet, plate cm.110,5x65 - 3 cooking areas (included 1 Head end filler strip mod.TPA-9) • **DE** Gas-griddleplatte 1/3 gerillt + 2/3 glatt hartverchromt SUPERCHROME (Moca Approved), mit offenem Unterbau, platte cm.110,5x65 - 3 Heizzonen (inbegriffen 1 Abschluss-Element mod.TPA-9) • **FR** Plaque gaz 1/3 nervurée + 2/3 lisse chromée AW770:AW833approved), sur armoire ouvert, plaque cm.110,5x65 - 3 zones de cuisson (inclus 1 Élément de jonction top mod.TPA-9) • **ES** Fry-top gas 1/3 estriado + 2/3 liso cromado SUPERCHROME (Moca Approved), sobre mueble abierto, plancha cm.110,5x65 - 3 zonas de cocción (incluida 1 Chapa de cierre para top mod. TPA-9)

**cm. 120x 90x 90h**



⚡ 27 kW  
23.220 kcal/h

**5.973,00**  
198 / 1,34



**FTL-916G FRY-TOP GAS LISCIO, SU MOBILE A GIORNO, PIASTRA CM.150,5X65 - 4 ZONE DI COTTURA (INCLUSA 1 TESTATA CHIUSURA PIANO MOD. TPA-9)**

09231651

**EN** Gas Fry-top smooth griddle, on open cabinet, plate cm.150,5x65 - 4 cooking areas (included 1 Head end filler strip mod.TPA-9) • **DE** Gas-griddleplatte glatt, mit offenem Unterbau, platte cm.150,5x65 - 4 Heizzonen (inbegriffen 1 Abschluss-Element mod.TPA-9) • **FR** Plaque gaz lisse, sur armoire ouvert, plaque cm.150,5x65 - 4 zones de cuisson (inclus 1 Élément de jonction top mod.TPA-9) • **ES** Fry-top gas liso, sobre mueble abierto, plancha cm.150,5x65 - 4 zonas de cocción (incluida 1 Chapa de cierre para top mod. TPA-9)

**cm. 160x 90x 90h**



⚡ 36 kW  
30.960 kcal/h

**6.322,00**  
266 / 1,96

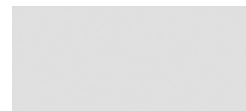

**FTL-916GS FRY-TOP GAS LISCIO CROMATO SUPERCHROME (MOCA APPROVED), SU MOBILE A GIORNO, PIASTRA CM.150,5X65 - 4 ZONE DI COTTURA (INCLUSA 1 TESTATA CHIUSURA PIANO MOD.TPA-9)**

09231654

**EN** Gas Fry-top smooth chromed griddle SUPERCHROME (Moca Approved), on open cabinet, plate cm.150,5x65 - 4 cooking areas (included 1 Head end filler strip mod.TPA-9) • **DE** Gas-griddleplatte glatt hartverchromt SUPERCHROME (Moca Approved), mit offenem Unterbau, platte cm.150,5x65 - 4 Heizzonen (inbegriffen 1 Abschluss-Element mod.TPA-9) • **FR** Plaque gaz lisse chromée SUPERCHROME (Moca Approved), sur armoire ouvert, plaque cm.150,5x65 - 4 zones de cuisson (inclus 1 Élément de jonction top mod. TPA-9) • **ES** Fry-top gas liso cromado SUPERCHROME (Moca Approved), sobre mueble abierto, plancha cm.150,5x65 - 4 zonas de cocción (incluida 1 Chapa de cierre para top mod.TPA-9)

**cm. 160x 90x 90h**

⚡ 36 kW  
30.960 kcal/h

**7.228,00**  
266 / 1,96



MOD. \_\_\_\_\_  
COD. \_\_\_\_\_

DESCRIZIONE/DESCRIPTION/BEZEICHNUNG/DESCRIPTION/DESCRIPCIÓN  
DIMENSIONI/DIMENSIONS/ABMESSUNGEN/DIMENSIONS/DIMENSIONES

POTENZA/POWER/LEISTUNG/PUISSANCE/POTENCIA  
VOLTAGGIO/VOLTAGE/SPANNUNG/VOLTAGE/VOLTAJE

⚡ kW  
kcal/h

⚡ kW  
V~  
Hz

PREZZO/PRICE €  
PREIS/PRIX/PRECIO €  
KG / M<sup>3</sup>

**CWK-94ET**  
09080431

**GRIGLIA CONTACT SU MOBILE A GIORNO -  
COTTURA DIRETTA SU RESISTENZA IN ACCIAIO  
INOX CM. 27X63 RIBALTABILE (INCLUSA 1  
TESTATA CHIUSURA PIANO MOD.TPA-9)**  
EN CONTACT Grill threephase on open cabinet -  
rotatable stainless steel grill cm. 27x63 (included 1  
Head end filler strip mod.TPA-9) • DE Wurstbrater  
dreiphasig KONTAKT mit offenem Unterbau - Drehbaren  
Heizelement aus Edelstahl cm. 27x63 (inbegriffen 1  
Abschluss-Element mod.TPA-9) • FR Grillade triphase  
CONTACT sur armoire ouvert- Grille inox rotatif cm  
27x63 (inclus 1 Élément de jonction top mod.TPA-9)  
• ES Parrilla trifásico CONTACT sobre mueble abierto  
- Parrilla giratoria de acero inox cm 27x63 (incluida 1  
Chapa de cierre para top mod.TPA-9)  
**cm. 40x 90x 90h**



⚡ 5,415 kW **2.946,00**  
400V~3N 69 / 0,46  
50/60 Hz

**CWK-98ET**  
09080831

**GRIGLIA CONTACT SU MOBILE A GIORNO -  
COTTURA DIRETTA SU RESISTENZA IN ACCIAIO  
INOX CM. 55X63 RIBALTABILE - 2 ZONE DI  
COTTURA (INCLUSA 1 TESTATA CHIUSURA  
PIANO MOD.TPA-9)**  
EN CONTACT Grill threephase on open cabinet -  
rotatable stainless steel grill cm. 55x63 - 2 cooking areas  
(included 1 Head end filler strip mod.TPA-9) • DE  
Wurstbrater dreiphasig KONTAKT mit offenem Unterbau  
- Drehbaren Heizelement aus Edelstahl cm. 55x63 - 2  
Heizzonen (inbegriffen 1 Abschluss-Element mod.TPA-9)  
• FR Grillade triphase CONTACT sur armoire ouvert-  
Grille inox rotatif cm 55x63 - 2 zones de cuisson (inclus  
1 Élément de jonction top mod.TPA-9) • ES Parrilla  
trifásico CONTACT sobre mueble abierto - Parrilla  
giratoria de acero inox cm 55x63 - 2 zonas de cocción  
(incluida 1 Chapa de cierre para top mod.TPA-9)  
**cm. 80x 90x 90h**



⚡ 10,83 kW **4.039,00**  
400V~3N 105 / 0,89  
50/60 Hz

**CW-94ET**  
09080430

**GRIGLIA TRIFASE SU MOBILE A GIORNO  
GRIGLIA IN ACCIAIO INOX CM. 38X66  
REGOLABILE (INCLUSA 1 TESTATA CHIUSURA  
PIANO MOD.TPA-9)**  
EN Grill threephase on open cabinet Stainless steel  
adjustable grill cm. 38x66 (included 1 Head end filler  
strip mod.TPA-9) • DE Wurstbrater dreiphasig mit  
offenem Unterbau Einstellbarer Rost aus Nirosta cm.  
38x66 (inbegriffen 1 Abschluss-Element mod.TPA-9)  
• FR Grillade triphase sur armoire ouvert Grille réglable  
en acier inox cm 38x66 (inclus 1 Élément de jonction  
top mod.TPA-9) • ES Parrilla trifásico sobre mueble  
abierto Parrilla de acero inox regulable cm 38x66  
(incluida 1 Chapa de cierre para top mod.TPA-9)  
**cm. 40x 90x 90h**



⚡ 7,8 kW **2.295,00**  
400V~3N 71 / 0,46  
50/60 Hz

**CW-98ET**  
09080830

**GRIGLIA TRIFASE SU MOBILE A GIORNO N.  
2 GRIGLIE IN ACCIAIO INOX CM. 38X66  
REGOLABILI 2 ZONE DI COTTURA (INCLUSA 1  
TESTATA CHIUSURA PIANO MOD.TPA-9)**  
EN Grill threephase on open cabinet - N. 2 stainless  
steel adjustable grills cm. 38x66 - 2 cooking areas  
(included 1 Head end filler strip mod.TPA-9) • DE  
Wurstbrater dreiphasig mit offenem Unterbau - N. 2  
einstellbarer Roste aus Nirosta cm. 38x66 - 2 Heizzonen  
(inbegriffen 1 Abschluss-Element mod.TPA-9) • FR  
Grillade triphase sur armoire ouvert - N. 2 grilles  
réglable en acier inox cm. 38x66 - 2 zones de cuisson  
(inclus 1 Élément de jonction top mod.TPA-9) • ES  
Parrilla trifásico sobre mueble abierto - N. 2 parrillas  
de acero inox regulable cm 38x66 - 2 zonas de cocción  
(incluida 1 Chapa de cierre para top mod.TPA-9)  
**cm. 80x 90x 90h**



⚡ 15,6 kW **3.388,00**  
400V~3N 109 / 0,89  
50/60 Hz



Le immagini presentate non sono vincolanti. La ditta si riserva di apportare modifiche senza preavviso. • The pictures are purely representative. The manufacturer reserves the right to modify the technical data and models without previous notice. • Les images

LO

présentées ne nous engagent pas. La Société se réserve le droit d'apporter tout modification sans préavis. • Die dargestellten Abbildungen sind nicht verbindlich. Technische Änderungen vorbehalten. • Las imágenes presentadas no son vinculantes. El Fabricante se reserva el derecho de modificar sus productos sin previo aviso.

01/20

273



# GRIGLIE PIETRA LAVICA A GAS

MOD. \_\_\_\_\_  
COD. \_\_\_\_\_

DESCRIZIONE/DESCRIPTION/BEZEICHNUNG/DESCRIPTION/DESCRIPCIÓN  
DIMENSIONI/DIMENSIONS/ABMESSUNGEN/DIMENSIONS/DIMENSIONES

POTENZA/POWER/LEISTUNG/PUISSANCE/POTENCIA  
VOLTAGGIO/VOLTAGE/SPANNUNG/VOLTAGE/VOLTAJE

⚡ kW kcal/h  
⚡ kW V~ Hz

PREZZO/PRICE €  
PREIS/PRIX/PRECIO €  
KG / M<sup>3</sup>

**CW-94G**  
09250450

**GRIGLIA GAS-PIETRALAVICA SU MOBILE A GIORNO GRIGLIA IN ACCIAIO INOX CM. 38X66 REGOLABILE (INCLUSA 1 TESTATA CHIUSURA PIANO MOD.TPA-9)**

**EN** Charcoal grill gas on open cabinet - Stainless steel adjustable grill cm. 38x66 (included 1 Head end filler strip mod.TPA-9) • **DE** Gas-Lavasteingrill mit offenem Unterbau - Einstellbarer Rost aus Nirosta cm. 38x66 (inbegriffen 1 Abschluss-Element mod.TPA-9) • **FR** Grille a gaz en pierre de lave sur armoire ouvert - Grille réglable en acier inox cm. 38x66 (inclus 1 Elément de jonction top mod.TPA-9) • **ES** Parrilla a gas piedra lávica sobre mueble abierto - Parrilla de acero inox regulable 38x66 cm (incluida 1 Chapa de cierre para top mod.TPA-9)  
**cm. 40x 90x 90h**



⚡ 12 kW kcal/h  
10.320 kcal/h  
**2.235,00**  
77 / 0,46

**CW-98G**  
09250850

**GRIGLIA GAS-PIETRALAVICA SU MOBILE A GIORNO N. 2 GRIGLIE IN ACCIAIO INOX CM. 38X66 REGOLABILI 2 ZONE DI COTTURA (INCLUSA 1 TESTATA CHIUSURA PIANO MOD. TPA-9)**

**EN** Charcoal grill gas on open cabinet - N. 2 stainless steel adjustable grills cm. 38x66 - 2 cooking areas (included 1 Head end filler strip mod.TPA-9) • **DE** Gas-Lavasteingrill mit offenem Unterbau - N. 2 einstellbarer Roste aus Nirosta cm. 38x66 - 2 Heizzonen (inbegriffen 1 Abschluss-Element mod.TPA-9) • **FR** Grille à gaz en pierre de lave sur armoire ouvert N. 2 grilles en acier inox cm 38x66 - 2 zones de cuisson (inclus 1 Elément de jonction top mod.TPA-9) • **ES** Parrilla a gas piedra lávica sobre mueble abierto N. 2 parrilla de acero inox regulable cm 38x66 - 2 zonas de coccion (incluida 1 Chapa de cierre para top mod.TPA-9)  
**cm. 80x 90x 90h**



⚡ 24 kW kcal/h  
20.640 kcal/h  
**3.475,00**  
131 / 0,89

**F2/8-94ET**  
09090432

**FRIGGITRICE TRIFASE LT. 8+8 2 VASCHE CM. 14,8X35X32,7H 2 CESTI CM. 12X30X15H - FILTRO E COPERCHIO VASCA. PRODUZIONE PATATE: 12 KG/H (BACINELLA RACCOGLIOLIO ESCLUSA, VEDI MOD: BF30) (INCLUSA 1 TESTATA CHIUSURA PIANO MOD.TPA-9)**

**EN** Fryer threephase 8+8 lts - 2 Bowls cm. 14,8x35x32,7h - 2 baskets cm. 12x30x15h. Sieve and lid for pan. Production: 12 kg/h (Drip tray excluded, see mod: BF30) (included 1 Head end filler strip mod.TPA-9) • **DE** Friteuse dreiphasig lt. 8+8 - 2 Becken cm. 14,8x35x32,7h - 2 Korb cm. 12x30x15h. Einlegesieb und Deckel für Becken. Pommes frites: 12 kg/h (Fettauffangschale ausgeschlossen, sehen mod: BF30) (inbegriffen 1 Abschluss-Element mod.TPA-9) • **FR** Friteuse triphase lt. 8+8 - 2 Cuve cm. 14,8x35x32,7h - 2 Panier cm. 12x30x15h. Filtre, couvercle pour cuve. Production de pommes frites: 12 kg/h (Bac de récupération de l'huile exclus, voir mod: BF30) (inclus 1 Elément de jonction top mod.TPA-9) • **ES** Freidoras trifásico 8+8 lt. - 2Cuba cm. 14,8x35x32,7h - 2 cesta cm. 12x30x15hh. Filtro y tapa para cuba. Prod. patatas: 12 Kg/h (bandeja recoge aceite excluida, ver mod: BF30) (incluida 1 Chapa de cierre para top mod.TPA-9)  
**cm. 40x 90x 90h**



⚡ 12 kW  
400V~3N  
230V~3  
50/60 Hz  
**3.217,00**  
63 / 0,46

# FRIGGITRICI ELETTRICHE

MOD. \_\_\_\_\_  
COD. \_\_\_\_\_

DESCRIZIONE/DESCRIPTION/BEZEICHNUNG/DESCRIPTION/DESCRIPCIÓN  
DIMENSIONI/DIMENSIONS/ABMESSUNGEN/DIMENSIONS/DIMENSIONES

POTENZA/POWER/LEISTUNG/PUISSANCE/POTENCIA  
VOLTAGGIO/VOLTAGE/SPANNUNG/VOLTAGE/VOLTAJE

⚡ kW kcal/h  
⚡ kW V~ Hz

PREZZO/PRICE €  
PREIS/PRIX/PRECIO €  
KG / M<sup>3</sup>

**F18-94ET**  
09090430

**FRIGGITRICE TRIFASE LT. 18 VASCA CM. 31X34X33H 1 CESTO CM. 28X29X15H COPERCHIO VASCA - PROD. PATATE: 15 KG/H (BACINELLA RACCOGLIOLIO ESCLUSA, VEDI MOD: BF30) (INCLUSA 1 TESTATA CHIUSURA PIANO MOD.TPA-9)**

**EN** Fryer threephase 18 lts. - Bowl cm. 31x34x33h 1 basket cm. 28x29x15h - Lid for pan - Production: 15 kg/h (Drip tray excluded, see mod: BF30) (included 1 Head end filler strip mod.TPA-9) • **DE** Friteuse dreiphasig lt. 18 - Becken cm. 31x34x33h 1 Korb cm. 28x29x15h - Deckel für Becken - Pommes frites: 15 kg/h (Fettauffangschale ausgeschlossen, sehen mod: BF30) (inbegriffen 1 Abschluss-Element mod.TPA-9) • **FR** Friteuse triphase lt. 18 - Cuve cm. 31x34x33h 1 Panier cm. 28x29x15h Couvercle pour cuve - Production de pommes frites: 15 kg/h (Bac de récupération de l'huile exclus, voir mod: BF30) (inclus 1 Élément de jonction top mod.TPA-9) • **ES** Freidoras trifásico 18 lt. - Cuba cm. 31x34x33h 1 cesta cm. 28x29x15h - Tapa para cuba Producción patatas: 15 Kg/h (bandeja recoge aceite excluida, ver mod: BF30) (incluida 1 Chapa de cierre para top mod.TPA-9)  
**cm. 40x 90x 90h**



⚡ 15,9 kW **2.529,00**  
400V~3N 63 / 0,46  
50/60 Hz

**F25-94ET**  
09090431

**FRIGGITRICE TRIFASE LT. 25 VASCA CM. 31X51X33H - 2 CESTI CM. 13,5X45X15H COPERCHIO VASCA - PROD. PATATE: 25 KG/H (BACINELLA RACCOGLIOLIO ESCLUSA, VEDI MOD: BF30) (INCLUSA 1 TESTATA CHIUSURA PIANO MOD.TPA-9)**

**EN** Fryer threephase 25 lts. - Bowl cm. 31x51x33h 2 baskets cm. 13,5x45x15h - Lid for tank Production: 25 kg/h (Drip tray excluded, see mod: BF30) (included 1 Head end filler strip mod.TPA-9) • **DE** Friteuse dreiphasig lt. 25 - Becken cm. 31x51x33h 2 Körbe cm. 13,5x45x15h - Deckel für Becken Pommes frites: 25 kg/h (Fettauffangschale ausgeschlossen, sehen mod: BF30) (inbegriffen 1 Abschluss-Element mod.TPA-9) • **FR** Friteuse triphase lt. 25 - Cuve cm. 31x51x33h 2 Paniers cm. 13,5x45x15h - Couvercle pour cuve Production de pommes frites: 25 kg/h (Bac de récupération de l'huile exclus, voir mod: BF30) (inclus 1 Élément de jonction top mod.TPA-9) • **ES** Freidoras trifásico 25 lt. - Cuba cm. 31x51x33h 2 cestas cm. 13,5x45x15h - Tapa para cuba Producción patatas: 25 Kg/h (bandeja recoge aceite excluida, ver mod: BF30) (incluida 1 Chapa de cierre para top mod.TPA-9)  
**cm. 40x 90x 90h**

⚡ 22 kW **2.770,00**  
400V~3N 66 / 0,46  
50/60 Hz

# FRIGGITRICI ELETTRICHE

MOD. \_\_\_\_\_  
COD. \_\_\_\_\_

DESCRIZIONE/DESCRIPTION/BEZEICHNUNG/DESCRIPTION/DESCRIPCIÓN  
DIMENSIONI/DIMENSIONS/ABMESSUNGEN/DIMENSIONS/DIMENSIONES

POTENZA/POWER/LEISTUNG/PUISSANCE/POTENCIA  
VOLTAGGIO/VOLTAGE/SPANNUNG/VOLTAGE/VOLTAJE

⚡ kW kcal/h  
⚡ kW  
V~ Hz

PREZZO/PRICE €  
PREIS/PRIX/PRECIO €  
KG / M<sup>3</sup>

**F2/18-98ET** FRIGGITRICE TRIFASE LT. 18+18 2 VASCHE CM.  
09090830 **31X34X33H - 2 CESTI CM. 28X29X15H 2**  
**COPERCHI VASCHE - PROD. PATATE: 30 KG/H**  
**(BACINELLA RACCOGLIOLIO ESCLUSA, VEDI**  
**MOD: BF30) (INCLUSA 1 TESTATA CHIUSURA**  
**PIANO MOD.TPA-9)**

**EN** Fryer threephase 18+18 lts - 2 pans cm. 31x34x33h  
2 baskets cm. 28x29x15h - 2 lids for tank Production:  
30 kg/h (Drip tray excluded, see mod: BF30) (included  
1 Head end filler strip mod.TPA-9) • **DE** Friteuse  
dreiphasig lt. 18+18 - 2 Becken cm. 31x34x33h 2  
Körbe cm. 28x29x15h - 2 Deckel für Becken Pommes  
frites: 30 kg/h (Fettauffangschale ausgeschlossen, sehen  
mod: BF30) (inbegriffen 1 Abschluss-Element mod.  
TPA-9) • **FR** Friteuse triphase lt. 18+18 - 2 cuves cm.  
31x34x33h 2 paniers cm. 28x29x15h - 2 couvercles  
pour cuve Production de pommes frites: 30 kg/h (Bac de  
récupération de l'huile exclus, voir mod: BF30) (inclus  
1 Élément de jonction top mod.TPA-9) • **ES** Freidoras  
trifásico 18+18 lt. - 2 cubas cm. 31x34x33h 2 cestas  
cm. 28x29x15h - 2 tapas para cuba Producción  
patatas: 30 Kg/h (bandeja recoge aceite excluida, ver  
mod: BF30) (incluida 1 Chapa de cierre para top mod.  
TPA-9)  
**cm. 80x 90x 90h**



⚡ 31,8 kW **4.012,00**  
400V~3N 106 / 0,89  
50/60 Hz

**F2/25-98ET** FRIGGITRICE TRIFASE LT. 25+25 2 VASCHE CM.  
09090831 **31X51X33H - 4 CESTI CM. 13,5X45X15H 2**  
**COPERCHI VASCHE - PROD. PATATE: 50 KG/H**  
**(BACINELLA RACCOGLIOLIO ESCLUSA, VEDI**  
**MOD: BF30) (INCLUSA 1 TESTATA CHIUSURA**  
**PIANO MOD.TPA-9)**

**EN** Fryer threephase 25+25 lts. - 2 pans cm.  
31x51x33h 4 baskets cm. 13,5x45x15h - 2 lids for  
tank Production: 50 kg/h (Drip tray excluded, see  
mod: BF30) (included 1 Head end filler strip mod.  
TPA-9) • **DE** Friteuse dreiphasig lt. 25+25 - 2 Becken  
cm. 31x51x33h 4 Körbe cm. 13,5x45x15h - 2 Deckel  
für Becken Pommes frites: 50 kg/h (Fettauffangschale  
ausgeschlossen, sehen mod: BF30) (inbegriffen 1  
Abschluss-Element mod.TPA-9) • **FR** Friteuse triphase  
lt. 25+25 - 2 cuves cm. 31x51x33h 4 paniers cm.  
13,5x45x15h - 2 couvercles pour cuve Production de  
pommes frites: 50 kg/h (Bac de récupération de l'huile  
exclus, voir mod: BF30) (inclus 1 Élément de jonction  
top mod.TPA-9) • **ES** Freidoras trifásico 25+25 lt. - 2  
cubas cm. 31x51x33h 4 cestas cm. 13,5x45x15h - 2  
tapas para cuba Producción patatas: 50 Kg/h (bandeja  
recoge aceite excluida, ver mod: BF30) (incluida 1  
Chapa de cierre para top mod.TPA-9)  
**cm. 80x 90x 90h**

⚡ 44 kW **4.481,00**  
400V~3N 114 / 0,89  
50/60 Hz

# FRIGGITRICI A GAS

MOD. \_\_\_\_\_  
COD. \_\_\_\_\_

DESCRIZIONE/DESCRIPTION/BEZEICHNUNG/DESCRIPTION/DESCRIPCIÓN  
DIMENSIONI/DIMENSIONS/ABMESSUNGEN/DIMENSIONS/DIMENSIONES

POTENZA/POWER/LEISTUNG/PUISSANCE/POTENCIA  
VOLTAGGIO/VOLTAGE/SPANNUNG/VOLTAGE/VOLTAJE

⚡ kW  
kcal/h

PREZZO/PRICE €  
PREIS/PRIX/PRECIO €  
KG / M<sup>3</sup>

**F2/8-94G**  
09260452

**FRIGGITRICE GAS LT. 8+8 - 2 VASCHE CM. 15X35X36H 2 CESTI CM. 12X30X15H. FILTRO E COPERCHIO VASCA. PROD. PATATE: 12 KG/H (BACINELLA RACCOGLIOLIO ESCLUSA, VEDI MOD: BF30) (INCLUSA 1 TESTATA CHIUSURA PIANO MOD.TPA-9)**

**EN** Gas Fryer 8+8 lts - 2 pans cm. 15x35x36h 2 baskets cm. 12x30x15h. Sieve and lid for pan. Production: 12 kg/h (Drip tray excluded, see mod: BF30) (included 1 Head end filler strip mod.TPA-9)  
• **DE** Gas-Friteuse lt. 8+8 - 2 Becken cm. 15x35x36h 2 Körbe cm. 12x30x15h. Einlegesieb und Deckel für Becken. Pommes frites: 12 kg/h (Fettauffangschale ausgeschlossen, sehen mod: BF30) (inbegriffen 1 Abschluss-Element mod.TPA-9)  
• **FR** Friteuse à gaz lt. 8+8 - 2 cuves cm. 15x35x36h 2 paniers cm. 12x30x15h. Filtre, couvercle pour cuve. Production de pommes frites: 12 kg/h (Bac de récupération de l'huile exclus, voir mod: BF30) (inclus 1 Élément de jonction top mod.TPA-9)  
• **ES** Freidoras a gas 8+8 lt. - 2 cubas cm. 15x35x36h 2 cestas cm. 12x30x15h. Filtro y tapa para cuba. Prod. patatas: 12 Kg/h (bandeja recoge aceite excluida, ver mod: BF30) (incluida 1 Chapa de cierre para top mod.TPA-9)  
**cm. 40x 90x 90h**



⚡ 10 kW  
8.600 kcal/h

**3.699,00**  
63 / 0,46

**F18-94G**  
09260450

**FRIGGITRICE GAS LT. 18 VASCA CM. 24X51X44H - 1 CESTO CM. 21X45X15H COPERCHIO VASCA - PROD. PATATE: 15 KG/H (BACINELLA RACCOGLIOLIO ESCLUSA, VEDI MOD: BF30) (INCLUSA 1 TESTATA CHIUSURA PIANO MOD.TPA-9)**

**EN** Gas fryer 18 lts. - Bowl cm. 24x51x44h 1 basket cm. 21x45x15h - Lid for tank Production: 15 kg/h (Drip tray excluded, see mod: BF30) (included 1 Head end filler strip mod.TPA-9)  
• **DE** Gas-Friteuse lt. 18 - Becken cm. 24x51x44h 1 Korb cm. 21x45x15h - Deckel für Becken Pommes frites: 15 kg/h (Fettauffangschale ausgeschlossen, sehen mod: BF30) (inbegriffen 1 Abschluss-Element mod.TPA-9)  
• **FR** Friteuse à gaz lt. 18 - Cuve cm. 24x51x44h 1 Panier cm. 21x45x15h - Couvercle pour cuve Production de pommes frites: 15 kg/h (Bac de récupération de l'huile exclus, voir mod: BF30) (inclus 1 Élément de jonction top mod.TPA-9)  
• **ES** Freidoras a gas 18 lt. - Cuba cm. 24x51x44h 1 cesta cm. 21x45x15h - Tapa para cuba Producción patatas: 15 Kg/h (bandeja recoge aceite excluida, ver mod: BF30) (incluida 1 Chapa de cierre para top mod.TPA-9)  
**cm. 40x 90x 90h**



⚡ 15 kW  
12.900 kcal/h

**2.873,00**  
69 / 0,46

⚡ 0,005 kW  
230V~  
50 Hz

**F25-94G**  
09260451

**FRIGGITRICE GAS LT. 25 VASCA CM. 31X51X44H - 2 CESTI CM. 13,5X45X15H COPERCHIO VASCA - PROD. PATATE: 25 KG/H (BACINELLA RACCOGLIOLIO ESCLUSA, VEDI MOD: BF30) (INCLUSA 1 TESTATA CHIUSURA PIANO MOD.TPA-9)**

**EN** Gas fryer 25 lts - Pan cm. 31x51x44h 2 baskets cm. 13,5x45x15h - Lid for tank Production: 25 kg/h. (Drip tray excluded, see mod: BF30) (included 1 Head end filler strip mod.TPA-9)  
• **DE** Gas-Friteuse lt. 25 - Becken cm. 31x51x44h 2 Körbe cm. 13,5x45x15h - Deckel für Becken Production: 25 kg/h (Fettauffangschale ausgeschlossen, sehen mod: BF30) (inbegriffen 1 Abschluss-Element mod.TPA-9)  
• **FR** Friteuse à gaz lt. 25 - Cuve cm. 31x51x44h 2 Paniers cm. 13,5x45x15h - Couvercle pour cuve Pommes frites: 25 kg/h (Bac de récupération de l'huile exclus, voir mod: BF30) (inclus 1 Élément de jonction top mod.TPA-9)  
• **ES** Freidoras a gas 25 lt. - Cuba cm. 31x51x44h 2 cestas cm. 13,5x45x15h - Tapa para cuba Producción patatas: 25 Kg/h (bandeja recoge aceite excluida, ver mod: BF30) (incluida 1 Chapa de cierre para top mod.TPA-9)  
**cm. 40x 90x 90h**

⚡ 20 kW  
17.200 kcal/h

**3.124,00**  
75 / 0,46

⚡ 0,005 kW  
230V~  
50 Hz



Le immagini presentate non sono vincolanti. La ditta si riserva di apportare modifiche senza preavviso. • The pictures are purely representative. The manufacturer reserves the right to modify the technical data and models without previous notice. • Les images

**LO**

présentées ne nous engagent pas. La Société se réserve le droit d'apporter tout modification sans préavis. • Die dargestellten Abbildungen sind nicht verbindlich. Technische Änderungen vorbehalten. • Las imágenes presentadas no son vinculantes. El Fabricante se reserva el derecho de modificar sus productos sin previo aviso.

01/20

**277**

90

# FRIGGITRICI A GAS

MOD. \_\_\_\_\_  
COD. \_\_\_\_\_

DESCRIZIONE/DESCRIPTION/BEZEICHNUNG/DESCRIPTION/DESCRIPCIÓN  
DIMENSIONI/DIMENSIONS/ABMESSUNGEN/DIMENSIONS/DIMENSIONES

POTENZA/POWER/LEISTUNG/PUISSANCE/POTENCIA  
VOLTAGGIO/VOLTAGE/SPANNUNG/VOLTAGE/VOLTAJE

⚡ kW  
kcal/h

⚡ kW  
V~  
Hz

PREZZO/PRICE €  
PREIS/PRIX/PRECIO €  
KG / M<sup>3</sup>

**F2/18-98G**  
09260850

**FRIGGITRICE GAS LT. 18+18 2 VASCHE CM. 24X51X44H - 2 CESTI CM. 21X45X15H 2 COPERCHI VASCHE - PROD. PATATE: 30 KG/H (BACINELLA RACCOGLIOLIO ESCLUSA, VEDI MOD: BF30) (INCLUSA 1 TESTATA CHIUSURA PIANO MOD.TPA-9)**

**EN** Fryer gas 18+18 lts - 2 pans cm. 24x51x44h 2 baskets cm. 21x45x15h - 2 lids for tank Production: 30 kg/h (Drip tray excluded, see mod: BF30) (included 1 Head end filler strip mod.TPA-9) • **DE** Gas-Friteuse dreiphasig lt. 18+18 - 2 Becken cm. 24x51x44h 2 Körbe cm. 21x45x15h - 2 Deckel für Becken Pommes frites: 30 kg/h (Fettauffangschale ausgeschlossen, sehen mod: BF30) (inbegriffen 1 Abschluss-Element mod. TPA-9) • **FR** Friteuse à gaz lt. 18+18 - 2 cuves cm. 24x51x44h 2 paniers cm. 21x45x15h - 2 couvercles pour cuve Production de pommes frites: 30 kg/h (Bac de récupération de l'huile exclus, voir mod: BF30) (inclus 1 Élément de jonction top mod.TPA-9) • **ES** Freidoras a gas 18+18 lt. - 2 cubas cm. 24x51x44h 2 cestas cm. 21x45x15h - 2 tapas para cuba Producción patatas: 30 Kg/h (bandeja recoge aceite excluida, ver mod: BF30) (incluida 1 Chapa de cierre para top mod.TPA-9)  
**cm. 80x 90x 90h**



⚡ 30 kW  
25.770 kcal/h

**4.535,00**  
116 / 0,89

⚡ 0,01 kW  
230V~  
50 Hz

**F2/25-98G**  
09260851

**FRIGGITRICE GAS LT. 25+25 2 VASCHE CM. 31X51X44H - 4 CESTI CM. 13,5X45X15H 2 COPERCHI VASCHE - PROD. PATATE: 50 KG/H (BACINELLA RACCOGLIOLIO ESCLUSA, VEDI MOD: BF30) (INCLUSA 1 TESTATA CHIUSURA PIANO MOD.TPA-9)**

**EN** Fryer gas 25+25 lts - 2 pans cm. 31x51x44h 4 baskets cm. 13,5x45x15h - 2 lids for tank Production: 50 kg/h (Drip tray excluded, see mod: BF30) (included 1 Head end filler strip mod.TPA-9) • **DE** Gas-Friteuse dreiphasig lt. 25+25 - 2 Becken cm. 31x51x44h 4 Körbe cm. 13,5x45x15h - 2 Deckel für Becken Pommes frites: 50 kg/h (Fettauffangschale ausgeschlossen, sehen mod: BF30) (inbegriffen 1 Abschluss-Element mod. TPA-9) • **FR** Friteuse à gaz lt. 25+25 - 2 cuves cm. 31x51x44h 4 paniers cm. 13,5x45x15h - 2 couvercles pour cuve Production de pommes frites: 50 kg/h (Bac de récupération de l'huile exclus, voir mod: BF30) (inclus 1 Élément de jonction top mod.TPA-9) • **ES** Freidoras a gas 25+25 lt. - 2 cubas cm. 31x51x44h 4 cestas cm. 13,5x45x15h - 2 tapas para cuba Producción patatas: 50 Kg/h (bandeja recoge aceite excluida, ver mod: BF30) (incluida 1 Chapa de cierre para top mod.TPA-9)  
**cm. 80x 90x 90h**

⚡ 40 kW  
34.360 kcal/h

**5.080,00**  
126 / 0,89

⚡ 0,01 kW  
230V~  
50 Hz



# FRIGGITRICI ELETTRICHE DIGITALI

MOD. \_\_\_\_\_  
COD. \_\_\_\_\_

DESCRIZIONE/DESCRIPTION/BEZEICHNUNG/DESCRIPTION/DESCRIPCIÓN  
DIMENSIONI/DIMENSIONS/ABMESSUNGEN/DIMENSIONS/DIMENSIONES

POTENZA/POWER/LEISTUNG/PUISSANCE/POTENCIA  
VOLTAGGIO/VOLTAGE/SPANNUNG/VOLTAGE/VOLTAJE

⚡ kcal/h  
⚡ kW  
V~  
Hz

PREZZO/PRICE €  
PREIS/PRIX/PRECIO €  
KG / M<sup>3</sup>

**F18-94ETD**  
0915A430

**FRIGGITRICE ELETTRICA ELETTRONICA CON TOUCHSCREEN 7". CONSERVAZIONE A 110 °C O PRELAVORO A 160 °C CON O SENZA MELTING. POSSIBILITÀ DI INSERIRE IN MEMORIA FINO A 100 PROGRAMMI. SENSORE PRESENZA E LIVELLO MASSIMO OLIO. VASCA 18 LITRI CM.31X34X33H - 2 CESTI CM.13,5X29X15H - FILTRO E COPERCHIO VASCA. BACINELLA RACCOLTA OLIO CON SUPPORTO SU RUOTE E FILTRO 5 MICRON (PZ.100 INCLUSI). PRODUZIONE PATATE: 27 KG/H (INCLUSA 1 TESTATA CHIUSURA PIANO MOD.TPA-9)**

**EN** Electric electronic Fryer with a 7" TouchScreen. Conservation at 110 °C and preworking at 160 °C with or without Melting. Possibility to store in the memory up to 100 programs. Oil presence sensor and maximum level sensor. Bowl 18 lts cm.31x34x33h - 2 baskets cm.13,5x29x15h. Sieve and lid for pan. Oil collection basin with support on wheels with sieve 5 microns (pcs.100 included). Production: 27 kg/h (included 1 Head end filler strip mod.TPA-9) • **DE** ELEKTRONISCHE ELEKTRISCHE FRITEUSE mit TouchScreen 7". Aufbewahrung bei 110 °C oder Vorbearbeitung bei 160 °C mit oder ohne Melting. Es können bis zu 100 Programme gespeichert werden. Anwesenheits- sowie maximaler Ölstandsensoren. Becken 18 lt. cm.31x34x33h - 2 Körbe cm.13,5x29x15h. Einlegesieb und Deckel für Becken. Ölauffangbecken mit Halterung auf Rädern und 5-Mikron-Filter (Stk.100 inbegriffen). Pommes frites: 27 kg/h (inbegriffen 1 Abschluss-Element mod.TPA-9) • **FR** FRITEUSE ÉLECTRIQUE ÉLECTRONIQUE à Écran tactile 7". Conservation à 110 °C ou Pré-traitement à 160 °C avec ou sans Melting. Possibilité d'enregistrer jusqu'à 100 programmes en mémoire. Capteur de présence et de niveau maximal huile. Cuve 18 lt. cm.31x34x33h - 2 Paniers cm.13,5x29x15h. Filtre, couvercle pour cuve. Bassine de collecte de l'huile avec support sur roues et filtre 5 microns (pcs.100 inclus). Production de pommes frites: 27 kg/h (inclus 1 Élément de jonction top mod.TPA-9) • **ES** FREIDORA ELÉCTRICA ELECTRÓNICA con pantalla táctil de 7". Conservación a 110 °C o trabajo previo a 160 °C con o sin fusión. Se pueden almacenar hasta 100 programas en la memoria. Sensor de presencia y nivel máximo de aceite. Cuba de 18 litros cm. 31x34x33h - 2 cestas cm.13,5x29x15h. Filtro y tapa para cuba. Cubeta de recogida de aceite con soporte sobre ruedas y filtro de 5 micrones (pz.100 incluida). Prod. patatas: 27 Kg/h (incluida 1 Chapa de cierre para top mod.TPA-9)  
**cm. 40x 90x 90h**



⚡ 15,95 kW  
400V~3N  
50/60 Hz

**5.078,00**  
69 / 0,46

MOD. \_\_\_\_\_  
COD. \_\_\_\_\_

DESCRIZIONE/DESCRIPTION/BEZEICHNUNG/DESCRIPTION/DESCRIPCIÓN  
DIMENSIONI/DIMENSIONS/ABMESSUNGEN/DIMENSIONS/DIMENSIONES

POTENZA/POWER/LEISTUNG/PUISSANCE/POTENCIA  
VOLTAGGIO/VOLTAGE/SPANNUNG/VOLTAGE/VOLTAJE

⚡ kW kcal/h  
⚡ kW V~ Hz

PREZZO/PRICE €  
PREIS/PRIX/PRECIO €  
KG / M<sup>3</sup>

**F18-94ETDP 0915A431 FRIGGITRICE ELETTRICA ELETTRONICA CON TOUCHSCREEN 7". CONSERVAZIONE A 110 °C O PRELAVORO A 160 °C CON O SENZA MELTING. POSSIBILITÀ DI INSERIRE IN MEMORIA FINO A 100 PROGRAMMI. SENSORE PRESENZA E LIVELLO MASSIMO OLIO. POMPA FILTRAGGIO OLIO A CALDO MAX 180°C, PULIZIA VASCA, SVUOTAMENTO VASCA. VASCA 18 LITRI CM.31X34X33H - 2 CESTI CM.13,5X29X15H - FILTRO E COPERCHIO VASCA. BACINELLA RACCOLTA OLIO CON SUPPORTO SU RUOTE E FILTRO 5 MICRON (PZ.100 INCLUSI). PRODUZIONE PATATE: 27 KG/H (INCLUSA 1 TESTATA CHIUSURA PIANO MOD.TPA-9)**

**EN** Electric electronic Fryer with a 7" TouchScreen. Conservation at 110 °C and preworking at 160 °C with or without Melting. Possibility to store in the memory up to 100 programs. Oil presence sensor and maximum level sensor. Pump for filter the hot oil max 180°C, Tank cleaning, Tank emptying. Bowl 18 lts cm.31x34x33h - 2 baskets cm.13,5x29x15h. Sieve and lid for pan. Oil collection basin with support on wheels with sieve 5 microns (pcs.100 included). Production: 27 kg/h (included 1 Head end filler strip mod.TPA-9) • **DE** ELEKTRONISCHE ELEKTRISCHE FRITEUSE mit TouchScreen 7". Aufbewahrung bei 110 °C oder Vorbearbeitung bei 160 °C mit oder ohne Melting. Es können bis zu 100 Programme gespeichert werden. Anwesenheits- sowie maximaler Ölstandsensoren. Heißölfilterpumpe max 180°C, Tankreinigung, Tankentleerung. Becken 18 lt. cm.31x34x33h - 2 Körbe cm.13,5x29x15h. Einlegesieb und Deckel für Becken. Olaufangbecken mit Halterung auf Rädern und 5-Mikron-Filter (Stk.100 inbegriffen). Pommes frites: 27 kg/h (inbegriffen 1 Abschluss-Element mod.TPA-9) • **FR** FRITEUSE ÉLECTRIQUE ÉLECTRONIQUE à Écran tactile 7". Conservation à 110 °C ou Pré-traitement à 160 °C avec ou sans Melting. Possibilité d'enregistrer jusqu'à 100 programmes en mémoire. Capteur de présence et de niveau maximal huile. Pompe filtration huile à chaud max 180°C, nettoyage cuve, vidange cuve. Cuve 18 lt. cm.31x34x33h - 2 Paniers cm.13,5x29x15h. Filtre, couvercle pour cuve. Bassine de collecte de l'huile avec support sur roues et filtre 5 microns (pcs.100 inclus). Production de pommes frites: 27 kg/h (inclus 1 Élément de jonction top mod.TPA-9) • **ES** FREIDORA ELÉCTRICA ELECTRÓNICA con pantalla táctil de 7". Conservación a 110 °C o trabajo previo a 160 °C con o sin fusión. Se pueden almacenar hasta 100 programas en la memoria. Sensor de presencia y nivel máximo de aceite. Bomba de filtrado de aceite caliente, máximo 180 °C, limpieza del tanque, vaciado del tanque. Cuba de 18 litros cm. 31x34x33h - 2 cestas cm.13,5x29x15h. Filtro y tapa para cuba. Cubeta de recogida de aceite con soporte sobre ruedas y filtro de 5 micrones (pz.100 incluida). Prod. patatas: 27 Kg/h (incluida 1 Chapa de cierre para top mod.TPA-9)  
**cm. 40x 90x 90h**



⚡ 16,2 kW 7.779,00  
400V~3N 79 / 0,46  
50/60 Hz

MOD. \_\_\_\_\_  
COD. \_\_\_\_\_

DESCRIZIONE/DESCRIPTION/BEZEICHNUNG/DESCRIPTION/DESCRIPCIÓN  
DIMENSIONI/DIMENSIONS/ABMESSUNGEN/DIMENSIONS/DIMENSIONES

POTENZA/POWER/LEISTUNG/PUISSANCE/POTENCIA  
VOLTAGGIO/VOLTAGE/SPANNUNG/VOLTAGE/VOLTAJE

⚡ kW  
kcal/h

⚡ kW  
V~  
Hz

PREZZO/PRICE €  
PREIS/PRIX/PRECIO €  
KG / M<sup>3</sup>

**F18-94ETDPS FRIGGITRICE ELETTRICA ELETTRONICA CON TOUCHSCREEN 7". CONSERVAZIONE A 110 °C O PRELAVORO A 160 °C CON O SENZA MELTING. POSSIBILITÀ DI INSERIRE IN MEMORIA FINO A 100 PROGRAMMI. SENSORE PRESENZA E LIVELLO MASSIMO OLIO. POMPA FILTRAGGIO OLIO A CALDO MAX 180°C, PULIZIA VASCA, SVUOTAMENTO VASCA. 2 SOLLEVATORI CESTI INTEGRATI. VASCA 18 LITRI CM.31X34X33H - 2 CESTI CM.13,5X29X15H - FILTRO E COPERCHIO VASCA. BACINELLA RACCOLTA OLIO CON SUPPORTO SU RUOTE E FILTRO 5 MICRON (PZ.100 INCLUSI). PRODUZIONE PATATE: 27 KG/H (INCLUSA 1 TESTATA CHIUSURA PIANO MOD.TPA-9)**

**EN** Electric electronic Fryer with a 7" TouchScreen. Conservation at 110 °C and preworking at 160 °C with or without Melting. Possibility to store in the memory up to 100 programs. Oil presence sensor and maximum level sensor. Pump for filter the hot oil max 180°C, Tank cleaning, Tank emptying. 2 Lifter for baskets integrated. Bowl 18 lts cm.31x34x33h - 2 baskets cm.13,5x29x15h. Sieve and lid for pan. Oil collection basin with support on wheels with sieve 5 microns (pcs.100 included). Production: 27 kg/h (included 1 Head end filler strip mod.TPA-9) • **DE** ELEKTRONISCHE ELEKTRISCHE FRITEUSE mit TouchScreen 7". Aufbewahrung bei 110 °C oder Vorbearbeitung bei 160 °C mit oder ohne Melting. Es können bis zu 100 Programme gespeichert werden. Anwesenheits- sowie maximaler Ölstandsensor. Heißölfilterpumpe max 180°C, Tankreinigung, Tankentleerung. Integrierte 2 Korbheber. Becken 18 lt. cm.31x34x33h - 2 Körbe cm.13,5x29x15h. Einlegesieb und Deckel für Becken. Ölauffangbecken mit Halterung auf Rädern und 5-Mikron-Filter (Stk.100 inbegriffen). Pommes frites: 27 kg/h (inbegriffen 1 Abschluss-Element mod.TPA-9) • **FR** FRITEUSE ÉLECTRIQUE ÉLECTRONIQUE à Écran tactile 7". Conservation à 110 °C ou Pré-traitement à 160 °C avec ou sans Melting. Possibilité d'enregistrer jusqu'à 100 programmes en mémoire. Capteur de présence et de niveau maximal huile. Pompe filtration huile à chaud max 180°C, nettoyage cuve, vidange cuve. 2 Élévateurs paniers intégrés. Cuve 18 lt. cm.31x34x33h - 2 Paniers cm.13,5x29x15h. Filtre, couvercle pour cuve. Bassine de collecte de l'huile avec support sur roues et filtre 5 microns (pcs.100 inclus). Production de pommes frites: 27 kg/h (inclus 1 Élément de jonction top mod.TPA-9) • **ES** FREIDORA ELÉCTRICA ELECTRÓNICA con pantalla táctil de 7". Conservación a 110 °C o trabajo previo a 160 °C con o sin fusión. Se pueden almacenar hasta 100 programas en la memoria. Sensor de presencia y nivel máximo de aceite. Bomba de filtrado de aceite caliente, máximo 180 °C, limpieza del tanque, vaciado del tanque. 2 Elevadores de cesta integrados. Cuba de 18 litros cm. 31x34x33h - 2 cestas cm.13,5x29x15h. Filtro y tapa para cuba. Cubeta de recogida de aceite con soporte sobre ruedas y filtro de 5 micrones (pz.100 incluida). Prod. patatas: 27 Kg/h (incluida 1 Chapa de cierre para top mod.TPA-9)  
**cm. 40x 90x 90h**



⚡ 16,55 kW  
400V~3N  
50/60 Hz

**9.670,00**  
89 / 0,46

MOD. \_\_\_\_\_  
COD. \_\_\_\_\_

DESCRIZIONE/DESCRIPTION/BEZEICHNUNG/DESCRIPTION/DESCRIPCIÓN  
DIMENSIONI/DIMENSIONS/ABMESSUNGEN/DIMENSIONS/DIMENSIONES

POTENZA/POWER/LEISTUNG/PUISSANCE/POTENCIA  
VOLTAGGIO/VOLTAGE/SPANNUNG/VOLTAGE/VOLTAJE

⚡ kW kcal/h  
⚡ kW V~ Hz

PREZZO/PRICE €  
PREIS/PRIX/PRECIO €  
KG / M<sup>3</sup>

**F2/18-98ETD FRIGGITRICE ELETTRICA ELETTRONICA CON TOUCHSCREEN 7". CONSERVAZIONE A 110 °C O PRELAVORO A 160 °C CON O SENZA MELTING. POSSIBILITÀ DI INSERIRE IN MEMORIA FINO A 100 PROGRAMMI. SENSORE PRESENZA E LIVELLO MASSIMO OLIO. 2 VASCHE 18 LITRI CM.31X34X33H - 4 CESTI CM.13,5X29X15H - FILTRI E COPERCHI VASCHE. 2 BACINELLE RACCOLTA OLIO CON SUPPORTO SU RUOTE E FILTRO 5 MICRON (PZ.100 INCLUSI). PRODUZIONE PATATE: 54 KG/H (INCLUSA 1 TESTATA CHIUSURA PIANO MOD.TPA-9)**

**EN** Electric electronic Fryer with a 7" TouchScreen. Conservation at 110 °C and preworking at 160 °C with or without Melting. Possibility to store in the memory up to 100 programs. Oil presence sensor and maximum level sensor. 2 bowls 18 lts cm.31x34x33h - 4 baskets cm.13,5x29x15h. 2 Sieve and lid for pan. 2 Oil collection basin with support on wheels with sieve 5 microns (pcs.100 included). Production: 54 kg/h (included 1 Head end filler strip mod.TPA-9)

• **DE** ELEKTRONISCHE ELEKTRISCHE FRITEUSE mit TouchScreen 7". Aufbewahrung bei 110 °C oder Vorbearbeitung bei 160 °C mit oder ohne Melting. Es können bis zu 100 Programme gespeichert werden.

Anwesenheits- sowie maximaler Ölstandsensor. 2 Becken 18 lt. cm.31x34x33h - 4 Körbe cm.13,5x29x15h. 2 Einlegesieb und Deckel für Becken. Ölauffangbecken mit Halterung auf Rädern und 5-Mikron-Filter (Stk.100 inbegriffen). Pommes frites: 54 kg/h (inbegriffen 1 Abschluss-Element mod.TPA-9)

• **FR** FRITEUSE ÉLECTRIQUE ÉLECTRONIQUE à Écran tactile 7". Conservation à 110 °C ou Pré-traitement à 160 °C avec ou sans Melting. Possibilité d'enregistrer jusqu'à 100 programmes en mémoire. Capteur de présence et de niveau maximal huile. 2 Cuves 18 lt. cm.31x34x33h - 4 Paniers cm.13,5x29x15h. 2 Filtre, couvercle pour cuve.

2 Bassine de collecte de l'huile avec support sur roues et filtre 5 microns (pcs.100 inclus). Production de pommes frites: 54 kg/h (inclus 1 Élément de jonction top mod.TPA-9)

• **ES** FREIDORA ELÉCTRICA ELECTRÓNICA con pantalla táctil de 7". Conservación a 110 °C o trabajo previo a 160 °C con o sin fusión. Se pueden almacenar hasta 100 programas en la memoria. Sensor de presencia y nivel máximo de aceite. 2 Cubas de 18 litros cm. 31x34x33h - 4 cestas cm.13,5x29x15h. 2 Filtros y tapas para cuba. 2 Cubetas de recogida de aceite con soporte sobre ruedas y filtro de 5 micrones (pz.100 incluida). Prod. patatas: 54 Kg/h (incluida 1 Chapa de cierre para top mod.TPA-9)

**cm. 80x 90x 90h**



⚡ 31,9 kW **9.156,00**  
400V~3N 118 / 0,89  
50/60 Hz

# FRIGGITRICI ELETTRICHE DIGITALI

MOD. \_\_\_\_\_  
COD. \_\_\_\_\_

DESCRIZIONE/DESCRIPTION/BEZEICHNUNG/DESCRIPTION/DESCRIPCIÓN  
DIMENSIONI/DIMENSIONS/ABMESSUNGEN/DIMENSIONS/DIMENSIONES

POTENZA/POWER/LEISTUNG/PUISSANCE/POTENCIA  
VOLTAGGIO/VOLTAGE/SPANNUNG/VOLTAGE/VOLTAJE

⚡ kW  
kcal/h

⚡ kW  
V~  
Hz

PREZZO/PRICE €  
PREIS/PRIX/PRECIO €  
KG / M<sup>3</sup>

F2/18-98ETDP  
0915A831

**FRIGGITRICE ELETTRICA ELETTRONICA CON TOUCHSCREEN 7". CONSERVAZIONE A 110 °C O PRELAVORO A 160 °C CON O SENZA MELTING. POSSIBILITÀ DI INSERIRE IN MEMORIA FINO A 100 PROGRAMMI. SENSORE PRESENZA E LIVELLO MASSIMO OLIO. 2 POMPE FILTRAGGIO OLIO A CALDO MAX 180°C, PULIZIA VASCA, SVUOTAMENTO VASCA. 2 VASCHE 18 LITRI CM.31X34X33H - 4 CESTI CM.13,5X29X15H - FILTRI E COPERCHI VASCHE. 2 BACINELLE RACCOLTA OLIO CON SUPPORTO SU RUOTE E FILTRO 5 MICRON (PZ.100 INCLUSI). PRODUZIONE PATATE: 54 KG/H (INCLUSA 1 TESTATA CHIUSURA PIANO MOD.TPA-9)**

**EN** Electric electronic Fryer with a 7" TouchScreen. Conservation at 110 °C and preworking at 160 °C with or without Melting. Possibility to store in the memory up to 100 programs. Oil presence sensor and maximum level sensor. 2 Pump for filter the hot oil max 180°C, Tank cleaning, Tank emptying. 2 bowls 18 lts cm.31x34x33h - 4 baskets cm.13,5x29x15h. 2 Sieve and lid for pan. 2 Oil collection basin with support on wheels with sieve 5 microns (pcs.100 included). Production: 54 kg/h (included 1 Head end filler strip mod.TPA-9) • **DE** ELEKTRONISCHE ELEKTRISCHE FRITEUSE mit TouchScreen 7". Aufbewahrung bei 110 °C oder Vorbearbeitung bei 160 °C mit oder ohne Melting. Es können bis zu 100 Programme gespeichert werden. Anwesenheits- sowie maximaler Ölstandsensoren. 2 Heißölfilterpumpe max 180°C, Tankreinigung, Tankentleerung. 2 Becken 18 lt. cm.31x34x33h - 4 Körbe cm.13,5x29x15h. 2 Einlegesieb und Deckel für Becken. 2 Ölauffangbecken mit Halterung auf Rädern und 5-Mikron-Filter (Stk.100 inbegriffen). Pommes frites: 54 kg/h (inbegriffen 1 Abschluss-Element mod. TPA-9) • **FR** FRITEUSE ÉLECTRIQUE ÉLECTRONIQUE à Écran tactile 7". Conservation à 110 °C ou Pré-traitement à 160 °C avec ou sans Melting. Possibilité d'enregistrer jusqu'à 100 programmes en mémoire. Capteur de présence et de niveau maximal huile. 2 Pompe filtration huile à chaud max 180°C, nettoyage cuve, vidange cuve. 2 Cuves 18 lt. cm.31x34x33h - 4 Paniers cm.13,5x29x15h. 2 Filtre, couvercle pour cuve. 2 Bassine de collecte de l'huile avec support sur roues et filtre 5 microns (pcs.100 inclus). Production de pommes frites: 54 kg/h (inclus 1 Élément de jonction top mod. TPA-9) • **ES** FREIDORA ELÉCTRICA ELECTRÓNICA con pantalla táctil de 7". Conservación a 110 °C o trabajo previo a 160 °C con o sin fusión. Se pueden almacenar hasta 100 programas en la memoria. Sensor de presencia y nivel máximo de aceite. 2 Bomba de filtrado de aceite caliente, máximo 180 °C, limpieza del tanque, vaciado del tanque. 2 Cubas de 18 litros cm. 31x34x33h - 4 cestas cm.13,5x29x15h. 2 Filtros y tapas para cuba. 2 Cubetas de recogida de aceite con soporte sobre ruedas y filtro de 5 micrones (pz.100 incluida). Prod. patatas: 54 Kg/h (incluida 1 Chapa de cierre para top mod.TPA-9)  
**cm. 80x 90x 90h**



⚡ 32,4 kW **14.558,00**  
400V~3N 138 / 0,89  
50/60 Hz



Le immagini presentate non sono vincolanti. La ditta si riserva di apportare modifiche senza preavviso. • The pictures are purely representative. The manufacturer reserves the right to modify the technical data and models without previous notice. • Les images

LO

présentées ne nous engagent pas. La Société se réserve le droit d'apporter tout modification sans préavis. • Die dargestellten Abbildungen sind nicht verbindlich. Technische Änderungen vorbehalten. • Las imágenes presentadas no son vinculantes. El Fabricante se reserva el derecho de modificar sus productos sin previo aviso.

01/20

283

90



# FRIGGITRICI ELETTRICHE DIGITALI

MOD. \_\_\_\_\_  
COD. \_\_\_\_\_

DESCRIZIONE/DESCRIPTION/BEZEICHNUNG/DESCRIPTION/DESCRIPCIÓN  
DIMENSIONI/DIMENSIONS/ABMESSUNGEN/DIMENSIONS/DIMENSIONES

POTENZA/POWER/LEISTUNG/PUISSANCE/POTENCIA  
VOLTAGGIO/VOLTAGE/SPANNUNG/VOLTAGE/VOLTAJE

⚡ kW kcal/h  
⚡ kW V~ Hz

PREZZO/PRICE €  
PREIS/PRIX/PRECIO €  
KG / M<sup>3</sup>

**F2/18-98ETDPS FRIGGITRICE ELETTRICA ELETTRONICA CON TOUCHSCREEN 7". CONSERVAZIONE A 110 °C O PRELAVORO A 160 °C CON O SENZA MELTING. POSSIBILITÀ DI INSERIRE IN MEMORIA FINO A 100 PROGRAMMI. SENSORE PRESENZA E LIVELLO MASSIMO OLIO. 2 POMPE FILTRAGGIO OLIO A CALDO MAX 180°C, PULIZIA VASCA, SVUOTAMENTO VASCA. 4 SOLLEVATORI CESTI INTEGRATI. 2 VASCHE 18 LITRI CM.31X34X33H - 4 CESTI CM.13,5X29X15H - FILTRI E COPERCHI VASCHE. 2 BACINELLE RACCOLTA OLIO CON SUPPORTO SU RUOTE E FILTRO 5 MICRON (PZ.100 INCLUSI). PRODUZIONE PATATE: 54 KG/H (INCLUSA 1 TESTATA CHIUSURA PIANO MOD.TPA-9)**

**EN** Electric electronic Fryer with a 7" TouchScreen. Conservation at 110 °C and preworking at 160 °C with or without Melting. Possibility to store in the memory up to 100 programs. Oil presence sensor and maximum level sensor. 2 Pump for filter the hot oil max 180°C, Tank cleaning, Tank emptying. 4 Lifter for baskets integrated. 2 bowls 18 lts cm.31x34x33h - 4 baskets cm.13,5x29x15h. 2 Sieve and lid for pan. 2 Oil collection basin with support on wheels with sieve 5 microns (pcs.100 included). Production: 54 kg/h (included 1 Head end filler strip mod.TPA-9)

• **DE** ELEKTRONISCHE ELEKTRISCHE FRITEUSE mit TouchScreen 7". Aufbewahrung bei 110 °C oder Vorbearbeitung bei 160 °C mit oder ohne Melting. Es können bis zu 100 Programme gespeichert werden. Anwesenheits- sowie maximaler Ölstandsensoren. 2 Heißölfilterpumpe max 180°C, Tankreinigung, Tankentleerung. Integrierte 4 Korbheber. 2 Becken 18 lt. cm.31x34x33h - 4 Körbe cm.13,5x29x15h. 2 Einlegesieb und Deckel für Becken. 2 Ölauffangbecken mit Halterung auf Rädern und 5-Mikron-Filter (Stk.100 inbegriffen). Pommes frites: 54 kg/h (inbegriffen 1 Abschluss-Element mod.TPA-9)

• **FR** FRITEUSE ÉLECTRIQUE ÉLECTRONIQUE à Écran tactile 7". Conservation à 110 °C ou Pré-traitement à 160 °C avec ou sans Melting. Possibilité d'enregistrer jusqu'à 100 programmes en mémoire. Capteur de présence et de niveau maximal huile. 2 Pompe filtration huile à chaud max 180°C, nettoyage cuve, vidange cuve. 4 Élévateurs paniers intégrés. 2 Cuve 18 lt. cm.31x34x33h - 4 Paniers cm.13,5x29x15h. 2 Filtre, couvercle pour cuve. 2 Bassine de collecte de l'huile avec support sur roues et filtre 5 microns (pcs.100 inclus). Production de pommes frites: 54 kg/h (inclus 1 Élément de jonction top mod. TPA-9)

• **ES** FREIDORA ELÉCTRICA ELECTRÓNICA con pantalla táctil de 7". Conservación a 110 °C o trabajo previo a 160 °C con o sin fusión. Se pueden almacenar hasta 100 programas en la memoria. Sensor de presencia y nivel máximo de aceite. 2 Bomba de filtrado de aceite caliente, máximo 180 °C, limpieza del tanque, vaciado del tanque. 4 Elevadores de cesta integrados. 2 Cubas de 18 litros cm. 31x34x33h - 4 cestas cm.13,5x29x15h. 2 Filtros y tapas para cuba. 2 Cubetas de recogida de aceite con soporte sobre ruedas y filtro de 5 micrones (pz.100 incluida). Prod. patatas: 54 Kg/h (incluida 1 Chapa de cierre para top mod. TPA-9)

**cm. 80x 90x 90h**



⚡ 33,1 kW **18.340,00**  
400V~3N 158 / 0,89  
50/60 Hz

# FRIGGITRICI ELETTRICHE DIGITALI

MOD. \_\_\_\_\_  
COD. \_\_\_\_\_

DESCRIZIONE/DESCRIPTION/BEZEICHNUNG/DESCRIPTION/DESCRIPCIÓN  
DIMENSIONI/DIMENSIONS/ABMESSUNGEN/DIMENSIONS/DIMENSIONES

POTENZA/POWER/LEISTUNG/PUISSANCE/POTENCIA  
VOLTAGGIO/VOLTAGE/SPANNUNG/VOLTAGE/VOLTAJE

⚡ kcal/h  
⚡ kW  
V~  
Hz

PREZZO/PRICE €  
PREIS/PRIX/PRECIO €  
KG / M<sup>3</sup>

**F25-94ETD**  
0915B430

**FRIGGITRICE ELETTRICA ELETTRONICA CON TOUCHSCREEN 7". CONSERVAZIONE A 110 °C O PRELAVORO A 160 °C CON O SENZA MELTING. POSSIBILITÀ DI INSERIRE IN MEMORIA FINO A 100 PROGRAMMI. SENSORE PRESENZA E LIVELLO MASSIMO OLIO. VASCA 25 LITRI CM.31X51X33H - 2 CESTI CM.13,5X45X15H - FILTRO E COPERCHIO VASCA. BACINELLA RACCOLTA OLIO CON SUPPORTO SU RUOTE E FILTRO 5 MICRON (PZ.100 INCLUSI). PRODUZIONE PATATE: 35 KG/H (INCLUSA 1 TESTATA CHIUSURA PIANO MOD.TPA-9)**

**EN** Electric electronic Fryer with a 7" TouchScreen. Conservation at 110 °C and preworking at 160 °C with or without Melting. Possibility to store in the memory up to 100 programs. Oil presence sensor and maximum level sensor. Bowl 25 lts cm.31x51x33h - 2 baskets cm.13,5x45x15h. Sieve and lid for pan. Oil collection basin with support on wheels with sieve 5 microns (pcs.100 included). Production: 35 Kg/h (included 1 Head end filler strip mod.TPA-9) • **DE** ELEKTRONISCHE ELEKTRISCHE FRITEUSE mit TouchScreen 7". Aufbewahrung bei 110 °C oder Vorbearbeitung bei 160 °C mit oder ohne Melting. Es können bis zu 100 Programme gespeichert werden. Anwesenheits- sowie maximaler Ölstandsensor. Becken 25 lt. cm.31x51x33h - 2 Körbe cm.13,5x45x15h. Einlegesieb und Deckel für Becken. Ölauffangbecken mit Halterung auf Rädern und 5-Mikron-Filter (Stk.100 inbegriffen). Pommes frites: 35 kg/h (inbegriffen 1 Abschluss-Element mod.TPA-9) • **FR** FRITEUSE ÉLECTRIQUE ÉLECTRONIQUE à Écran tactile 7". Conservation à 110 °C ou Pré-traitement à 160 °C avec ou sans Melting. Possibilité d'enregistrer jusqu'à 100 programmes en mémoire. Capteur de présence et de niveau maximal huile. Cuve 25 lt. cm.31x51x33h - 2 Paniers cm.13,5x45x15h. Filtre, couvercle pour cuve. Bassine de collecte de l'huile avec support sur roues et filtre 5 microns (pcs.100 inclus). Production de pommes frites: 35 kg/h (inclus 1 Élément de jonction top mod.TPA-9) • **ES** FREIDORA ELÉCTRICA ELECTRÓNICA con pantalla táctil de 7". Conservación a 110 °C o trabajo previo a 160 °C con o sin fusión. Se pueden almacenar hasta 100 programas en la memoria. Sensor de presencia y nivel máximo de aceite. Cuba de 25 litros cm. 31x51x33h - 2 cestas cm.13,5x45x15h. Filtro y tapa para cuba. Cubeta de recogida de aceite con soporte sobre ruedas y filtro de 5 micrones (pz.100 incluida). Prod. patatas: 35 kg/h (incluida 1 Chapa de cierre para top mod.TPA-9)

**cm. 40x 90x 90h**



⚡ 22,05 kW  
400V~3N  
50/60 Hz

**5.278,00**  
72 / 0,46

MOD. \_\_\_\_\_  
COD. \_\_\_\_\_

DESCRIZIONE/DESCRIPTION/BEZEICHNUNG/DESCRIPTION/DESCRIPCIÓN  
DIMENSIONI/DIMENSIONS/ABMESSUNGEN/DIMENSIONS/DIMENSIONES

POTENZA/POWER/LEISTUNG/PUISSANCE/POTENCIA  
VOLTAGGIO/VOLTAGE/SPANNUNG/VOLTAGE/VOLTAJE

⚡ kW  
kcal/h

⚡ kW  
V~  
Hz

PREZZO/PRICE €  
PREIS/PRIX/PRECIO €  
KG / M<sup>3</sup>

**F25-94ETDP**  
0915B431

**FRIGGITRICE ELETTRICA ELETTRONICA CON TOUCHSCREEN 7". CONSERVAZIONE A 110 °C O PRELAVORO A 160 °C CON O SENZA MELTING. POSSIBILITÀ DI INSERIRE IN MEMORIA FINO A 100 PROGRAMMI. SENSORE PRESENZA E LIVELLO MASSIMO OLIO. POMPA FILTRAGGIO OLIO A CALDO MAX 180°C, PULIZIA VASCA, SVUOTAMENTO VASCA. VASCA 25 LITRI CM.31X51X33H - 2 CESTI CM.13,5X45X15H - FILTRO E COPERCHIO VASCA. BACINELLA RACCOLTA OLIO CON SUPPORTO SU RUOTE E FILTRO 5 MICRON (PZ.100 INCLUSI). PRODUZIONE PATATE: 35 KG/H (INCLUSA 1 TESTATA CHIUSURA PIANO MOD.TPA-9)**

**EN** Electric electronic Fryer with a 7" TouchScreen. Conservation at 110 °C and preworking at 160 °C with or without Melting. Possibility to store in the memory up to 100 programs. Oil presence sensor and maximum level sensor. Pump for filter the hot oil max 180°C, Tank cleaning, Tank emptying. Bowl 25 lts cm.31x51x33h - 2 baskets cm.13,5x45x15h. Sieve and lid for pan. Oil collection basin with support on wheels with sieve 5 microns (pcs.100 included). Production: 35 Kg/h (included 1 Head end filler strip mod.TPA-9) • **DE** ELEKTRONISCHE ELEKTRISCHE FRITEUSE mit TouchScreen 7". Aufbewahrung bei 110 °C oder Vorbearbeitung bei 160 °C mit oder ohne Melting. Es können bis zu 100 Programme gespeichert werden. Anwesenheits- sowie maximaler Ölstandsensoren. Heißölfilterpumpe max 180°C, Tankreinigung, Tankentleerung. Becken 25 lt. cm.31x51x33h - 2 Körbe cm.13,5x45x15h. Einlegesieb und Deckel für Becken. Olaufangbecken mit Halterung auf Rädern und 5-Mikron-Filter (Stk.100 inbegriffen). Pommes frites: 35 kg/h (inbegriffen 1 Abschluss-Element mod.TPA-9) • **FR** FRITEUSE ÉLECTRIQUE ÉLECTRONIQUE à Écran tactile 7". Conservation à 110 °C ou Pré-traitement à 160 °C avec ou sans Melting. Possibilité d'enregistrer jusqu'à 100 programmes en mémoire. Capteur de présence et de niveau maximal huile. Pompe filtration huile à chaud max 180°C, nettoyage cuve, vidange cuve. Cuve 25 lt. cm.31x51x33h - 2 Paniers cm.13,5x45x15h. Filtre, couvercle pour cuve. Bassine de collecte de l'huile avec support sur roues et filtre 5 microns (pcs.100 inclus). Production de pommes frites: 35 kg/h (inclus 1 Élément de jonction top mod.TPA-9) • **ES** FREIDORA ELÉCTRICA ELECTRÓNICA con pantalla táctil de 7". Conservación a 110 °C o trabajo previo a 160 °C con o sin fusión. Se pueden almacenar hasta 100 programas en la memoria. Sensor de presencia y nivel máximo de aceite. Bomba de filtrado de aceite caliente, máximo 180 °C, limpieza del tanque, vaciado del tanque. Cuba de 25 litros cm. 31x51x33h - 2 cestas cm.13,5x45x15h. Filtro y tapa para cuba. Cubeta de recogida de aceite con soporte sobre ruedas y filtro de 5 micrones (pz.100 incluida). Prod. patatas: 35 kg/h (incluida 1 Chapa de cierre para top mod.TPA-9)

**cm. 40x 90x 90h**



⚡ 22,3 kW  
400V~3N  
50/60 Hz

**7.979,00**  
82 / 0,46

MOD. \_\_\_\_\_  
COD. \_\_\_\_\_

DESCRIZIONE/DESCRIPTION/BEZEICHNUNG/DESCRIPTION/DESCRIPCIÓN  
DIMENSIONI/DIMENSIONS/ABMESSUNGEN/DIMENSIONS/DIMENSIONES

POTENZA/POWER/LEISTUNG/PUISSANCE/POTENCIA  
VOLTAGGIO/VOLTAGE/SPANNUNG/VOLTAGE/VOLTAJE

⚡ kW kcal/h  
⚡ kW V~ Hz

PREZZO/PRICE €  
PREIS/PRIX/PRECIO €  
KG / M<sup>3</sup>

**F25-94ETDPS FRIGGITRICE ELETTRICA ELETTRONICA CON TOUCHSCREEN 7". CONSERVAZIONE A 110 °C O PRELAVORO A 160 °C CON O SENZA MELTING. POSSIBILITÀ DI INSERIRE IN MEMORIA FINO A 100 PROGRAMMI. SENSORE PRESENZA E LIVELLO MASSIMO OLIO. POMPA FILTRAGGIO OLIO A CALDO MAX 180°C, PULIZIA VASCA, SVUOTAMENTO VASCA. SOLLEVATORI CESTI INTEGRATI. VASCA 25 LITRI CM.31X51X33H - 2 CESTI CM.13,5X45X15H - FILTRO E COPERCHIO VASCA. BACINELLA RACCOLTA OLIO CON SUPPORTO SU RUOTE E FILTRO 5 MICRON (PZ.100 INCLUSI). PRODUZIONE PATATE: 35 KG/H (INCLUSA 1 TESTATA CHIUSURA PIANO MOD.TPA-9)**

**EN** Electric electronic Fryer with a 7" TouchScreen. Conservation at 110 °C and preworking at 160 °C with or without Melting. Possibility to store in the memory up to 100 programs. Oil presence sensor and maximum level sensor. Pump for filter the hot oil max 180°C, Tank cleaning, Tank emptying. 2 Lifter for baskets integrated. Bowl 25 lts cm.31x51x33h - 2 baskets cm.13,5x45x15h. Sieve and lid for pan. Oil collection basin with support on wheels with sieve 5 microns (pcs.100 included). Production: 35 Kg/h (included 1 Head end filler strip mod.TPA-9) • **DE** ELEKTRONISCHE ELEKTRISCHE FRITEUSE mit TouchScreen 7". Aufbewahrung bei 110 °C oder Vorbearbeitung bei 160 °C mit oder ohne Melting. Es können bis zu 100 Programme gespeichert werden. Anwesenheits- sowie maximaler Ölstandsensor. Heißölfilterpumpe max 180°C, Tankreinigung, Tankentleerung. Integrierte 2 Korbheber. Becken 25 lt. cm.31x51x33h - 2 Körbe cm.13,5x45x15h. Einlegesieb und Deckel für Becken. Ölauffangbecken mit Halterung auf Rädern und 5-Mikron-Filter (Stk.100 inbegriffen). Pommes frites: 35 kg/h (inbegriffen 1 Abschluss-Element mod.TPA-9) • **FR** FRITEUSE ÉLECTRIQUE ÉLECTRONIQUE à Écran tactile 7". Conservation à 110 °C ou Pré-traitement à 160 °C avec ou sans Melting. Possibilité d'enregistrer jusqu'à 100 programmes en mémoire. Capteur de présence et de niveau maximal huile. Pompe filtration huile à chaud max 180°C, nettoyage cuve, vidange cuve. 2 Élévateurs paniers intégrés. Cuve 25 lt. cm.31x51x33h - 2 Paniers cm.13,5x45x15h. Filtre, couvercle pour cuve. Bassine de collecte de l'huile avec support sur roues et filtre 5 microns (pcs.100 inclus). Production de pommes frites: 35 kg/h (inclus 1 Élément de jonction top mod.TPA-9) • **ES** FREIDORA ELÉCTRICA ELECTRÓNICA con pantalla táctil de 7". Conservación a 110 °C o trabajo previo a 160 °C con o sin fusión. Se pueden almacenar hasta 100 programas en la memoria. Sensor de presencia y nivel máximo de aceite. Bomba de filtrado de aceite caliente, máximo 180 °C, limpieza del tanque, vaciado del tanque. 2 Elevadores de cesta integrados. Cuba de 25 litros cm. 31x51x33h - 2 cestas cm.13,5x45x15h. Filtro y tapa para cuba. Cubeta de recogida de aceite con soporte sobre ruedas y filtro de 5 micrones (pz.100 incluida). Prod. patatas: 35 kg/h (incluida 1 Chapa de cierre para top mod.TPA-9)  
**cm. 40x 90x 90h**



⚡ 22,65 kW 9.870,00  
400V~3N 92 / 0,46  
50/60 Hz

MOD. \_\_\_\_\_  
COD. \_\_\_\_\_

DESCRIZIONE/DESCRIPTION/BEZEICHNUNG/DESCRIPTION/DESCRIPCIÓN  
DIMENSIONI/DIMENSIONS/ABMESSUNGEN/DIMENSIONS/DIMENSIONES

POTENZA/POWER/LEISTUNG/PUISSANCE/POTENCIA  
VOLTAGGIO/VOLTAGE/SPANNUNG/VOLTAGE/VOLTAJE

⚡ kW kcal/h  
⚡ kW V~ Hz

PREZZO/PRICE €  
PREIS/PRIX/PRECIO €  
KG / M<sup>3</sup>

**F2/25-98ETD FRIGGITRICE ELETTRICA ELETTRONICA CON TOUCHSCREEN 7". CONSERVAZIONE A 110 °C O PRELAVORO A 160 °C CON O SENZA MELTING. POSSIBILITÀ DI INSERIRE IN MEMORIA FINO A 100 PROGRAMMI. SENSORE PRESENZA E LIVELLO MASSIMO OLIO. 2 VASCHE 25 LITRI CM.31X51X33H - 4 CESTI CM.13,5X45X15H - FILTRI E COPERCHI VASCHE. 2 BACINELLE RACCOLTA OLIO CON SUPPORTO SU RUOTE E FILTRO 5 MICRON (PZ.100 INCLUSI). PRODUZIONE PATATE: 70 KG/H (INCLUSA 1 TESTATA CHIUSURA PIANO MOD.TPA-9)**

0915B830



⚡ 44,1 kW 9.556,00  
400V~3N 126 / 0,89  
50/60 Hz

**EN** Electric electronic Fryer with a 7" TouchScreen. Conservation at 110 °C and preworking at 160 °C with or without Melting. Possibility to store in the memory up to 100 programs. Oil presence sensor and maximum level sensor. 2 bowl 25 lts cm.31x51x33h - 4 baskets cm.13,5x45x15h. 2 Sieve and lid for pan. 2 Oil collection basin with support on wheels with sieve 5 microns (pcs.100 included). Production: 70 kg/h (included 1 Head end filler strip mod.TPA-9)

• **DE** ELEKTRONISCHE ELEKTRISCHE FRITEUSE mit TouchScreen 7". Aufbewahrung bei 110 °C oder Vorbearbeitung bei 160 °C mit oder ohne Melting. Es können bis zu 100 Programme gespeichert werden.

Anwesenheits- sowie maximaler Ölstandsensor. 2 Becken 25 lt. cm.31x51x33h - 4 Körbe cm.13,5x45x15h. 2 Einlegesieb und Deckel für Becken. Ölauffangbecken mit Halterung auf Rädern und 5-Mikron-Filter (Stk.100 inbegriffen). Pommes frites: 70 kg/h (inbegriffen 1 Abschluss-Element mod.TPA-9)

• **FR** FRITEUSE ÉLECTRIQUE ÉLECTRONIQUE à Écran tactile 7". Conservation à 110 °C ou Pré-traitement à 160 °C avec ou sans Melting. Possibilité d'enregistrer jusqu'à 100 programmes en mémoire. Capteur de présence et de niveau maximal huile. 2 Cuves 25 lt. cm.31x51x33h - 4 Paniers cm.13,5x45x15h. 2 Filtre, couvercle pour cuve. 2 Bassine de collecte de l'huile avec support sur roues et filtre 5 microns (pcs.100 inclus). Production de pommes frites: 70 kg/h (inclus 1 Élément de jonction top mod.TPA-9)

• **ES** FREIDORA ELÉCTRICA ELECTRÓNICA con pantalla táctil de 7". Conservación a 110 °C o trabajo previo a 160 °C con o sin fusión. Se pueden almacenar hasta 100 programas en la memoria. Sensor de presencia y nivel máximo de aceite. 2 Cubas de 25 litros cm. 31x51x33h - 4 cestas cm.13,5x45x15h. 2 Filtros y tapas para cuba. 2 Cubetas de recogida de aceite con soporte sobre ruedas y filtro de 5 micrones (pz.100 incluida). Prod. patatas: 70 kg/h (incluida 1 Chapa de cierre para top mod.TPA-9)

**cm. 80x 90x 90h**



# FRIGGITRICI ELETTRICHE DIGITALI

MOD. \_\_\_\_\_  
COD. \_\_\_\_\_

DESCRIZIONE/DESCRIPTION/BEZEICHNUNG/DESCRIPTION/DESCRIPCIÓN  
DIMENSIONI/DIMENSIONS/ABMESSUNGEN/DIMENSIONS/DIMENSIONES

POTENZA/POWER/LEISTUNG/PUISSANCE/POTENCIA  
VOLTAGGIO/VOLTAGE/SPANNUNG/VOLTAGE/VOLTAJE

⚡ kW kcal/h  
⚡ kW V~ Hz

PREZZO/PRICE €  
PREIS/PRIX/PRECIO €  
KG / M<sup>3</sup>

**F2/25-98ETDP FRIGGITRICE ELETTRICA ELETTRONICA CON TOUCHSCREEN 7". CONSERVAZIONE A 110 °C O PRELAVORO A 160 °C CON O SENZA MELTING. POSSIBILITÀ DI INSERIRE IN MEMORIA FINO A 100 PROGRAMMI. SENSORE PRESENZA E LIVELLO MASSIMO OLIO. 2 POMPE FILTRAGGIO OLIO A CALDO MAX 180°C, PULIZIA VASCA, SVUOTAMENTO VASCA. 2 VASCHE 25 LITRI CM.31X51X33H - 4 CESTI CM.13,5X45X15H - FILTRI E COPERCHI VASCHE. 2 BACINELLE RACCOLTA OLIO CON SUPPORTO SU RUOTE E FILTRO 5 MICRON (PZ.100 INCLUSI). PRODUZIONE PATATE: 70 KG/H (INCLUSA 1 TESTATA CHIUSURA PIANO MOD.TPA-9)**

0915B831



⚡ 44,6 kW **14.958,00**  
400V~3N 146 / 0,89  
50/60 Hz

**EN** Electric electronic Fryer with a 7" TouchScreen. Conservation at 110 °C and preworking at 160 °C with or without Melting. Possibility to store in the memory up to 100 programs. Oil presence sensor and maximum level sensor. 2 pump for filter the hot oil max 180°C, Tank cleaning, Tank emptying. 2 bowl 25 lts cm.31x51x33h - 4 baskets cm.13,5x45x15h. 2 Sieve and lid for pan. 2 Oil collection basin with support on wheels with sieve 5 microns (pcs.100 included). Production: 70 kg/h (included 1 Head end filler strip mod.TPA-9) • **DE** ELEKTRONISCHE ELEKTRISCHE FRITEUSE mit TouchScreen 7". Aufbewahrung bei 110 °C oder Vorbearbeitung bei 160 °C mit oder ohne Melting. Es können bis zu 100 Programme gespeichert werden. Anwesenheits- sowie maximaler Ölstandsensoren. 2 Heißölfilterpumpe max 180°C, Tankreinigung, Tankentleerung. 2 Becken 25 lt. cm.31x51x33h - 4 Körbe cm.13,5x45x15h. 2 Einlegesieb und Deckel für Becken. 2 Ölauffangbecken mit Halterung auf Rädern und 5-Mikron-Filter (Stk.100 inbegriffen). Pommes frites: 70 kg/h (inbegriffen 1 Abschluss-Element mod. TPA-9) • **FR** FRITEUSE ÉLECTRIQUE ÉLECTRONIQUE à Écran tactile 7". Conservation à 110 °C ou Pré-traitement à 160 °C avec ou sans Melting. Possibilité d'enregistrer jusqu'à 100 programmes en mémoire. Capteur de présence et de niveau maximal huile. 2 Pompe filtration huile à chaud max 180°C, nettoyage cuve, vidange cuve. 2 Cuves 25 lt. cm.31x51x33h - 4 Paniers cm.13,5x45x15h. 2 Filtre, couvercle pour cuve. 2 Bassine de collecte de l'huile avec support sur roues et filtre 5 microns (pcs.100 inclus). Production de pommes frites: 70 kg/h (inclus 1 Élément de jonction top mod. TPA-9) • **ES** FREIDORA ELÉCTRICA ELECTRÓNICA con pantalla táctil de 7". Conservación a 110 °C o trabajo previo a 160 °C con o sin fusión. Se pueden almacenar hasta 100 programas en la memoria. Sensor de presencia y nivel máximo de aceite. 2 Bomba de filtrado de aceite caliente, máximo 180 °C, limpieza del tanque, vaciado del tanque. 2 Cubas de 25 litros cm. 31x51x33h - 4 cestas cm.13,5x45x15h. 2 Filtros y tapas para cuba. 2 Cubetas de recogida de aceite con soporte sobre ruedas y filtro de 5 micrones (pz.100 incluida). Prod. patatas: 70 kg/h (incluida 1 Chapa de cierre para top mod.TPA-9)  
**cm. 80x 90x 90h**



Le immagini presentate non sono vincolanti. La ditta si riserva di apportare modifiche senza preavviso. • The pictures are purely representative. The manufacturer reserves the right to modify the technical data and models without previous notice. • Les images

LO

présentées ne nous engagent pas. La Société se réserve le droit d'apporter tout modification sans préavis. • Die dargestellten Abbildungen sind nicht verbindlich. Technische Änderungen vorbehalten. • Las imágenes presentadas no son vinculantes. El Fabricante se reserva el derecho de modificar sus productos sin previo aviso.

01/20

289

90

# FRIGGITRICI ELETTRICHE DIGITALI

MOD. \_\_\_\_\_  
COD. \_\_\_\_\_

DESCRIZIONE/DESCRIPTION/BEZEICHNUNG/DESCRIPTION/DESCRIPCIÓN  
DIMENSIONI/DIMENSIONS/ABMESSUNGEN/DIMENSIONS/DIMENSIONES

POTENZA/POWER/LEISTUNG/PUISSANCE/POTENCIA  
VOLTAGGIO/VOLTAGE/SPANNUNG/VOLTAGE/VOLTAJE

⚡ kW \_\_\_\_\_  
kcal/h \_\_\_\_\_  
V~ \_\_\_\_\_  
Hz \_\_\_\_\_

PREZZO/PRICE € \_\_\_\_\_  
PREIS/PRIX/PRECIO € \_\_\_\_\_  
KG / M<sup>3</sup> \_\_\_\_\_

**F2/25-98ETDPS FRIGGITRICE ELETTRICA ELETTRONICA CON TOUCHSCREEN 7". CONSERVAZIONE A 110 °C O PRELAVORO A 160 °C CON O SENZA MELTING. POSSIBILITÀ DI INSERIRE IN MEMORIA FINO A 100 PROGRAMMI. SENSORE PRESENZA E LIVELLO MASSIMO OLIO. 2 POMPE FILTRAGGIO OLIO A CALDO MAX 180°C, PULIZIA VASCA, SVUOTAMENTO VASCA. 4 SOLLEVATORI CESTI INTEGRATI. 2 VASCHE 25 LITRI CM.31X51X33H - 4 CESTI CM.13,5X45X15H - FILTRI E COPERCHI VASCHE. 2 BACINELLE RACCOLTA OLIO CON SUPPORTO SU RUOTE E FILTRO 5 MICRON (PZ.100 INCLUSI). PRODUZIONE PATATE: 70 KG/H (INCLUSA 1 TESTATA CHIUSURA PIANO MOD.TPA-9)**

**EN** Electric electronic Fryer with a 7" TouchScreen. Conservation at 110 °C and preworking at 160 °C with or without Melting. Possibility to store in the memory up to 100 programs. Oil presence sensor and maximum level sensor. 2 pump for filter the hot oil max 180°C, Tank cleaning, Tank emptying. 4 Lifter for baskets integrated. 2 bowl 25 lts cm.31x51x33h - 4 baskets cm.13,5x45x15h. 2 Sieve and lid for pan. 2 Oil collection basin with support on wheels with sieve 5 microns (pcs.100 included). Production: 70 kg/h (included 1 Head end filler strip mod.TPA-9)

• **DE** ELEKTRONISCHE ELEKTRISCHE FRITEUSE mit TouchScreen 7". Aufbewahrung bei 110 °C oder Vorbearbeitung bei 160 °C mit oder ohne Melting. Es können bis zu 100 Programme gespeichert werden. Anwesenheits- sowie maximaler Ölstandsensoren. 2 Heißölfilterpumpe max 180°C, Tankreinigung, Tankentleerung. Integrierte 4 Korbheber. 2 Becken 25 lt. cm.31x51x33h - 4 Körbe cm.13,5x45x15h. 2 Einlegesieb und Deckel für Becken. 2 Ölauffangbecken mit Halterung auf Rädern und 5-Mikron-Filter (Stk.100 inbegriffen). Pommes frites: 70 kg/h (inbegriffen 1 Abschluss-Element mod.TPA-9)

• **FR** FRITEUSE ÉLECTRIQUE ÉLECTRONIQUE à Écran tactile 7". Conservation à 110 °C ou Pré-traitement à 160 °C avec ou sans Melting. Possibilité d'enregistrer jusqu'à 100 programmes en mémoire. Capteur de présence et de niveau maximal huile. 2 Pompe filtration huile à chaud max 180°C, nettoyage cuve, vidange cuve. 4 Élévateurs paniers intégrés. 2 Cuve 25 lt. cm.31x51x33h - 4 Paniers cm.13,5x45x15h. 2 Filtre, couvercle pour cuve. 2 Bassine de collecte de l'huile avec support sur roues et filtre 5 microns (pcs.100 inclus). Production de pommes frites: 70 kg/h (inclus 1 Élément de jonction top mod. TPA-9)

• **ES** FREIDORA ELÉCTRICA ELECTRÓNICA con pantalla táctil de 7". Conservación a 110 °C o trabajo previo a 160 °C con o sin fusión. Se pueden almacenar hasta 100 programas en la memoria. Sensor de presencia y nivel máximo de aceite. 2 Bomba de filtrado de aceite caliente, máximo 180 °C, limpieza del tanque, vaciado del tanque. 4 Elevadores de cesta integrados. 2 Cubas de 25 litros cm. 31x51x33h - 4 cestas cm.13,5x45x15h. 2 Filtros y tapas para cuba. 2 Cubetas de recogida de aceite con soporte sobre ruedas y filtro de 5 micrones (pz.100 incluida). Prod. patatas: 70 kg/h (incluida 1 Chapa de cierre para top mod. TPA-9)

**cm. 80x 90x 90h**



⚡ 45,3 kW \_\_\_\_\_ **18.740,00**  
400V~3N \_\_\_\_\_ 166 / 0,89  
50/60 Hz \_\_\_\_\_

**BR80-98ETFI BRASIERA 80 LT. RIB. MANUALE VASCA FONDO INOX CON COPERCHIO**

**EN** 80 lts. manual tilt. brat pan - Stainless steel bottom with lid • **DE** Kippbratpfanne 80 lt. - Man. Kippung - inox boden. mit Deckel • **FR** Sautreuse 80 lt. basc. manuel - Fond inox avec couvercle • **ES** Sartén 80 lt. abat. manual - Fondo de acero inox. con tapa

**cm. 80x 90x 90h**



⚡ 12 kW \_\_\_\_\_ **5.721,00**  
400V~3N \_\_\_\_\_ 156 / 0,89  
50/60 Hz \_\_\_\_\_

01/20

**290**

Le immagini presentate non sono vincolanti. La ditta si riserva di apportare modifiche senza preavviso. • The pictures are purely representative. The manufacturer reserves the right to modify the technical data and models without previous notice. • Les images présentées ne nous engagent pas. La Société se réserve le

**LO**

droit d'apporter tout modification sans préavis. • Die dargestellten Abbildungen sind nicht verbindlich. Technische Änderungen vorbehalten. • Las imágenes presentadas no son vinculantes. El Fabricante se reserva el derecho de modificar sus productos sin previo aviso.



# BRASIERE RIBALTABILI ELETTRICHE

MOD. \_\_\_\_\_  
COD. \_\_\_\_\_

DESCRIZIONE/DESCRIPTION/BEZEICHNUNG/DESCRIPTION/DESCRIPCIÓN  
DIMENSIONI/DIMENSIONS/ABMESSUNGEN/DIMENSIONS/DIMENSIONES

POTENZA/POWER/LEISTUNG/PUISSANCE/POTENCIA  
VOLTAGGIO/VOLTAGE/SPANNUNG/VOLTAGE/VOLTAJE

⚡ kW  
kcal/h

⚡ kw  
V~  
Hz

PREZZO/PRICE €  
PREIS/PRIX/PRECIO €  
KG / M<sup>3</sup>

**BRM80-98ET/I BRASIERA 80 LT. RIB. AUTOMATICO VASCA  
FONDO INOX CON COPERCHIO**

092070836

EN 80 lts. automatic tilt. Brat pan - Stainless steel bottom with lid • DE Bratpfanne 80 lt. - Autom. Kippung - inox boden. mit Deckel • FR Sauteuse 80 lt. basc. automatique - Fond inox avec couvercle • ES Sartén 80 lt. abat. automática - Fondo de acero inox. con tapa  
**cm. 80x 90x 90h**



⚡ 12,1 kW  
400V~3N  
50 Hz

**6.989,00**  
162 / 0,89

**BR80-98GF/I BRASIERA 80 LT. RIB. MANUALE VASCA  
FONDO INOX CON COPERCHIO**

09240855

EN 80 lts. manual tilt. brat pan - Stainless steel bottom with lid • DE Kippbratpfanne 80 lt. - Man. Kippung - inox boden. mit Deckel • FR Sauteuse 80 lt. basc. manuel - Fond inox avec couvercle • ES Sartén 80 lt. abat. manual - Fondo de acero inox. con tapa  
**cm. 80x 90x 90h**



⚡ 22 kW  
18.920 kcal/h

**5.627,00**  
159 / 0,89

**BRM80-98GF/I BRASIERA 80 LT. RIB. AUTOMATICO VASCA  
FONDO INOX CON COPERCHIO**

09240856

EN 80 lts. automatic tilt. Brat pan - Stainless steel bottom with lid • DE Bratpfanne 80 lt. - Autom. Kippung - inox boden. mit Deckel • FR Sauteuse 80 lt. basc. automatique - Fond inox avec couvercle • ES Sartén 80 lt. abat. automática - Fondo de acero inox. con tapa  
**cm. 80x 90x 90h**



⚡ 22 kW  
18.920 kcal/h

**7.058,00**  
165 / 0,89

⚡ 0,1kW  
230V~  
50 Hz

**BRF-94ET BRASIERA FISSA MULTIFUNZIONALE ELETTRICA  
VASCA CM. 30X68X10H (INCLUSA 1 TESTATA  
CHIUSURA PIANO MOD.TPA-9)**

092070433

EN Electric multi-function fixed braising pan Bowl cm. 30x68x10h (included 1 Head end filler strip mod.TPA-9) • DE Elektrische Multifunktionsbratpfanne fest Becken cm. 30x68x10h (inbegriffen 1 Abschluss-Element mod. TPA-9) • FR Sauteuse fixe multifonction électrique Cuve cm. 30x68x10h (inclus 1 Élément de jonction top mod. TPA-9) • ES Sarten fija multifunción eléctrica Cuba cm. 30x68x10h (incluida 1 Chapa de cierre para top mod. TPA-9)  
**cm. 40x 90x 90h**



⚡ 5,2 kW  
400V~2N  
50/60 Hz

**3.260,00**  
79 / 0,46

**BRF-98ET BRASIERA FISSA MULTIFUNZIONALE ELETTRICA  
VASCA CM. 70X68X10H (INCLUSA 1 TESTATA  
CHIUSURA PIANO MOD.TPA-9)**

092070833

EN Electric multi-function fixed braising pan - Bowl cm. 70x68x10h (included 1 Head end filler strip mod.TPA-9) • DE Elektrische Multifunktionsbratpfanne fest - Becken cm. 70x68x10h (inbegriffen 1 Abschluss-Element mod. TPA-9) • FR Sauteuse fixe multifonction électrique - Cuve cm. 70x68x10h (inclus 1 Élément de jonction top mod.TPA-9) • ES Sarten fija multifunción eléctrica - Cuba cm. 70x68x10h (incluida 1 Chapa de cierre para top mod.TPA-9)  
**cm. 80x 90x 90h**



⚡ 10,4 kW  
400V~3N  
230V~3  
50/60 Hz

**4.710,00**  
126 / 0,89



Le immagini presentate non sono vincolanti. La ditta si riserva di apportare modifiche senza preavviso. • The pictures are purely representative. The manufacturer reserves the right to modify the technical data and models without previous notice. • Les images

LO

présentées ne nous engagent pas. La Société se réserve le droit d'apporter tout modification sans préavis. • Die dargestellten Abbildungen sind nicht verbindlich. Technische Änderungen vorbehalten. • Las imágenes presentadas no son vinculantes. El Fabricante se reserva el derecho de modificar sus productos sin previo aviso.

01/20

291

# BRASIERE FISSE MULTIFUNZIONE A GAS

MOD. \_\_\_\_\_  
COD. \_\_\_\_\_

DESCRIZIONE/DESCRIPTION/BEZEICHNUNG/DESCRIPTION/DESCRIPCIÓN  
DIMENSIONI/DIMENSIONS/ABMESSUNGEN/DIMENSIONS/DIMENSIONES

POTENZA/POWER/LEISTUNG/PUISSANCE/POTENCIA  
VOLTAGGIO/VOLTAGE/SPANNUNG/VOLTAGE/VOLTAJE

⚡ kW \_\_\_\_\_  
kcal/h \_\_\_\_\_  
V~ \_\_\_\_\_  
Hz \_\_\_\_\_

PREZZO/PRICE € \_\_\_\_\_  
PREIS/PRIX/PRECIO \_\_\_\_\_  
KG / M<sup>3</sup> \_\_\_\_\_

**BRF-94G**  
09240453

**BRASIERA FISSA MULTIFUNZIONALE GAS  
VASCA CM. 30X68X10H (INCLUSA 1 TESTATA  
CHIUSURA PIANO MOD.TPA-9)**

**EN** Gas multi-function fixed braising pan - Bowl cm. 30x68x10h (included 1 Head end filler strip mod.TPA-9)  
• **DE** Gas-Multifunktionsbratpfanne fest - Becken cm. 30x68x10h (inbegriffen 1 Abschluss-Element mod. TPA-9) • **FR** Sauteuse fixe multifonction à gaz - Cuve cm. 30x68x10h (inclus 1 Élément de jonction top mod. TPA-9) • **ES** Sarten fija multifunción a gas - Cuba cm. 30x68x10h (incluida 1 Chapa de cierre para top mod. TPA-9)  
**cm. 40x 90x 90h**



⚡ 9 kW \_\_\_\_\_ **3.795,00**  
7.740 kcal/h \_\_\_\_\_ 79 / 0,46

**BRF-98G**  
09240853

**BRASIERA FISSA MULTIFUNZIONALE GAS  
VASCA CM. 70X68X10H (INCLUSA 1 TESTATA  
CHIUSURA PIANO MOD.TPA-9)**

**EN** Gas multi-function fixed braising pan - Bowl cm. 70x68x10h (included 1 Head end filler strip mod.TPA-9)  
• **DE** Gas-Multifunktionsbratpfanne fest - Becken cm. 70x68x10h (inbegriffen 1 Abschluss-Element mod. TPA-9) • **FR** Sauteuse fixe multifonction à gaz - Cuve cm. 70x68x10h (inclus 1 Élément de jonction top mod. TPA-9) • **ES** Sarten fija multifunción a gas - Cuba cm. 70x68x10h (incluida 1 Chapa de cierre para top mod. TPA-9)  
**cm. 80x 90x 90h**



⚡ 18 kW \_\_\_\_\_ **5.419,00**  
15.480 kcal/h \_\_\_\_\_ 129 / 0,89

**BR120-912ET/I**  
09071235

**BRASIERA 120 LT. RIB. MANUALE VASCA  
FONDO INOX CON COPERCHIO**

**EN** 120 lts. manual tilt. brat pan - Stainless steel bottom with lid • **DE** Kippbratpfanne 120 Lt. - Man. Kippung - inox boden. mit Deckel • **FR** Sauteuse 120 lt. basc. manuel - Fond inox avec couvercle • **ES** Sartén 120 lt. abat. manual - Fondo de acero inox. con tapa  
**cm. 120x 90x 90h**



⚡ 18 kW \_\_\_\_\_ **8.330,00**  
400V~3N \_\_\_\_\_ 205 / 1,32  
50/60 Hz \_\_\_\_\_

**BRM120-912ET/I**  
09071236

**BRASIERA 120 LT. RIB. AUTOMATICO VASCA  
FONDO INOX CON COPERCHIO**

**EN** 120 lts. automatic tilt. Brat pan - Stainless steel bottom with lid • **DE** Bratpfanne 120 Lt. - Autom. Kippung - inox boden. mit Deckel • **FR** Sauteuse 120 lt. basc. automatique - Fond inox avec couvercle • **ES** Sartén 120 lt. abat. automática - Fondo de acero inox. con tapa  
**cm. 120x 90x 90h**



⚡ 18,1 kW \_\_\_\_\_ **9.587,00**  
400V~3N \_\_\_\_\_ 211 / 1,32  
50 Hz \_\_\_\_\_

**BR120-912GF/I**  
09241255

**BRASIERA 120 LT. RIB. MANUALE VASCA  
FONDO INOX CON COPERCHIO**

**EN** 120 lts. manual tilt. brat pan - Stainless steel bottom with lid • **DE** Kippbratpfanne 120 Lt. - Man. Kippung - inox boden. mit Deckel • **FR** Sauteuse 120 lt. basc. manuel - Fond inox avec couvercle • **ES** Sartén 120 lt. abat. manual - Fondo de acero inox. con tapa  
**cm. 120x 90x 90h**



⚡ 30 kW \_\_\_\_\_ **8.276,00**  
25.800 kcal/h \_\_\_\_\_ 208 / 1,32

# BRASIERE RIBALTABILI A GAS

MOD. \_\_\_\_\_  
COD. \_\_\_\_\_

DESCRIZIONE/DESCRIPTION/BEZEICHNUNG/DESCRIPTION/DESCRIPCIÓN  
DIMENSIONI/DIMENSIONS/ABMESSUNGEN/DIMENSIONS/DIMENSIONES

POTENZA/POWER/LEISTUNG/PUISSANCE/POTENCIA  
VOLTAGGIO/VOLTAGE/SPANNUNG/VOLTAGE/VOLTAJE

⚡ kW kcal/h  
⚡ kw V~ Hz

PREZZO/PRICE €  
PREIS/PRIX/PRECIO €  
KG / M<sup>3</sup>

**BRM120-912GF/I BRASIERA 120 LT. RIB. AUTOMATICO VASCA FONDO INOX CON COPERCHIO**

09241256

**EN** 120 lts. automatic tilt. Brat pan - Stainless steel bottom with lid • **DE** Bratpfanne 120 lt. - Autom. Kippung - inox boden. mit Deckel • **FR** Sauteuse 120 lt. basc. automatique - Fond inox avec couvercle • **ES** Sartén 120 lt. abat. automática - Fondo de acero inox. con tapa  
**cm. 120x 90x 90h**



⚡ 30 KW 9.863,00  
25.800 kcal/h 214 / 1,32

⚡ 0,1KW  
230V~  
50 Hz

**PL-92**  
09010200

**PIANO LAVORO SU MOBILE (INCLUSA 1 TESTATA CHIUSURA PIANO MOD.TPA-9)**  
**EN** Worktop on cabinet (included 1 Head end filler strip mod.TPA-9) • **DE** Arbeitsplatte mit Unterbau (inbegriffen 1 Abschluss-Element mod.TPA-9) • **FR** Plan de travail sur armoire (inclus 1 Élément de jonction top mod.TPA-9) • **ES** Sobre de trabajo sobre mueble (incluida 1 Chapa de cierre para top mod.TPA-9)  
**cm. 20x 90x 90h**



**832,00**  
45 / 0,46

**PLS-93**  
09010301

**PIANO LAVORO SU MOBILE A GIORNO (INCLUSA 1 TESTATA CHIUSURA PIANO MOD. TPA-9)**  
**EN** Worktop on open cabinet (included 1 Head end filler strip mod.TPA-9) • **DE** Arbeitsplatte mit offenem Unterbau (inbegriffen 1 Abschluss-Element mod.TPA-9) • **FR** Plan de travail sur armoire ouvert (inclus 1 Élément de jonction top mod.TPA-9) • **ES** Sobre de trabajo sobre mueble abierto (incluida 1 Chapa de cierre para top mod.TPA-9)  
**cm. 30x 90x 90h**



**849,00**  
47 / 0,46

**PLS-94**  
09010401

**cm. 40x 90x 90h**



**863,00**  
49 / 0,46

**PLS-96**  
09010601

**cm. 60x 90x 90h**



**1.281,00**  
59 / 0,68

**PLS-98**  
09010801

**cm. 80x 90x 90h**



**1.360,00**  
70 / 0,89



Le immagini presentate non sono vincolanti. La ditta si riserva di apportare modifiche senza preavviso. • The pictures are purely representative. The manufacturer reserves the right to modify the technical data and models without previous notice. • Les images

**LO**

présentées ne nous engagent pas. La Société se réserve le droit d'apporter tout modification sans préavis. • Die dargestellten Abbildungen sind nicht verbindlich. Technische Änderungen vorbehalten. • Las imágenes presentadas no son vinculantes. El Fabricante se reserva el derecho de modificar sus productos sin previo aviso.

01/20

**293**



MOD. \_\_\_\_\_  
COD. \_\_\_\_\_

DESCRIZIONE/DESCRIPTION/BEZEICHNUNG/DESCRIPTION/DESCRIPCIÓN  
DIMENSIONI/DIMENSIONS/ABMESSUNGEN/DIMENSIONS/DIMENSIONES

POTENZA/POWER/LEISTUNG/PUISSANCE/POTENCIA  
VOLTAGGIO/VOLTAGE/SPANNUNG/VOLTAGE/VOLTAJE

⚡ kW kcal/h  
⚡ kw V~ Hz

PREZZO/PRICE €  
PREIS/PRIX/PRECIO €  
KG / M<sup>3</sup>

**PL-93**  
09010300

**PIANO LAVORO SU MOBILE A GIORNO CASSETTO CM. 19X50X15H INOX (INCLUSA 1 TESTATA CHIUSURA PIANO MOD.TPA-9)**  
**EN** Worktop on open cabinet Drawer cm. 19x50x15h (included 1 Head end filler strip mod.TPA-9) • **DE** Arbeitsplatte mit offenem Unterbau. Schublade cm. 19x50x15h (inbegriffen 1 Abschluss-Element mod. TPA-9) • **FR** Plan de travail sur armoire ouvert. Tiroir inox cm. 19x50x15h (inclus 1 Élément de jonction top mod.TPA-9) • **ES** Sobre de trabajo con mueble abierto. Cajón cm. 19x50x15h inox (incluida 1 Chapa de cierre para top mod.TPA-9)  
**cm. 30x 90x 90h**



**1.077,00**  
50 / 0,46

**PL-94**  
09010400

**PIANO LAVORO SU MOBILE A GIORNO CASSETTO CON 1 BACINELLA GN 1/1 15H IN PLASTICA (INCLUSA 1 TESTATA CHIUSURA PIANO MOD.TPA-9)**  
**EN** Worktop on open cabinet Drawer with 1 plastic container GN 1/1 15h (included 1 Head end filler strip mod.TPA-9) • **DE** Arbeitsplatte mit offenem Unterbau Schublade mit 1 GN 1/1 15h Kunststoffbehälter (inbegriffen 1 Abschluss-Element mod.TPA-9) • **FR** Plan de travail sur armoire ouvert Tiroir avec bac en plastique GN 1/1 15h (inclus 1 Élément de jonction top mod. TPA-9) • **ES** Sobre de trabajo sobre mueble abierto Cajón con 1 contenedor GN 1/1 15h plástico (incluida 1 Chapa de cierre para top mod.TPA-9)  
**cm. 40x 90x 90h**



**1.055,00**  
54 / 0,46

**PL-96**  
09010600

**PIANO LAVORO SU MOBILE A GIORNO CASSETTO CM. 49X50X15H INOX (INCLUSA 1 TESTATA CHIUSURA PIANO MOD.TPA-9)**  
**EN** Worktop on open cabinet Drawer cm. 49x50x15h (included 1 Head end filler strip mod.TPA-9) • **DE** Arbeitsplatte mit offenem Unterbau. Schublade cm. 49x50x15h (inbegriffen 1 Abschluss-Element mod. TPA-9) • **FR** Plan de travail sur armoire ouvert. Tiroir inox cm. 49x50x15h (inclus 1 Élément de jonction top mod.TPA-9) • **ES** Sobre de trabajo con mueble abierto. Cajón cm. 49x50x15h inox (incluida 1 Chapa de cierre para top mod.TPA-9)  
**cm. 60x 90x 90h**



**1.494,00**  
70 / 0,68

**PL-98**  
09010800

**PIANO LAVORO SU MOBILE A GIORNO CASSETTO CON 2 BACINELLE GN 1/1 15H IN PLASTICA (INCLUSA 1 TESTATA CHIUSURA PIANO MOD.TPA-9)**  
**EN** Worktop on open cabinet Drawer with 2 plastic containers GN 1/1 15h (included 1 Head end filler strip mod.TPA-9) • **DE** Arbeitsplatte mit offenem Unterbau Schublade mit 2 GN 1/1 15h Kunststoffbehälter (inbegriffen 1 Abschluss-Element mod.TPA-9) • **FR** Plan de travail sur armoire ouvert Tiroir avec 2 bacs en plastique GN 1/1 15h (inclus 1 Élément de jonction top mod.TPA-9) • **ES** Sobre de trabajo sobre mueble abierto Cajón con 2 contenedores GN 1/1 15h plástico (incluida 1 Chapa de cierre para top mod.TPA-9)  
**cm. 80x 90x 90h**



**1.595,00**  
82 / 0,89

**LA-94**  
09020400

**LAVELLO SU MOBILE A GIORNO RUBINETTO A LEVA - VASCA CM. 30X35X15H (INCLUSA 1 TESTATA CHIUSURA PIANO MOD.TPA-9)**  
**EN** Sink unit on open cabinet - Lever type tap. Bowl cm. 30x35x15h (included 1 Head end filler strip mod. TPA-9) • **DE** Spülbecken Einhebel-Mischbatterie mit offenem Unterbau - Becken cm. 30x35x15h (inbegriffen 1 Abschluss-Element mod.TPA-9) • **FR** Bac-évier sur armoire ouvert avec robinetterie - Bac cm. 30x35x15h (inclus 1 Élément de jonction top mod.TPA-9) • **ES** Fregadero sobre mueble abierto - Grifo a palanca - Pileta cm. 30x35x15h (incluida 1 Chapa de cierre para top mod.TPA-9)  
**cm. 40x 90x 90h**



**1.273,00**  
53 / 0,46

MOD. \_\_\_\_\_  
COD. \_\_\_\_\_

DESCRIZIONE/DESCRIPTION/BEZEICHNUNG/DESCRIPTION/DESCRIPCIÓN  
DIMENSIONI/DIMENSIONS/ABMESSUNGEN/DIMENSIONS/DIMENSIONES

POTENZA/POWER/LEISTUNG/PUISSANCE/POTENCIA  
VOLTAGGIO/VOLTAGE/SPANNUNG/VOLTAGE/VOLTAJE

⚡ kW kcal/h  
⚡ kW V~ Hz

PREZZO/PRICE €  
PREIS/PRIX/PRECIO €  
KG / M<sup>3</sup>

## P-73/93-DX PORTA 300 DESTRA

08430300 **EN** Right door 300 • **DE** Rechte tür 300 • **FR** Porte droite 300 • **ES** Puerta derecha 300  
**cm. 29,5x 2,5x 47,5h**



**157,00**  
3 / 0,01

## P-74/94-DX PORTA 400 DESTRA

08430400 **EN** Right door 400 • **DE** Rechte tür 400 • **FR** Porte droite 400 • **ES** Puerta derecha 400  
**cm. 39,5x 2,5x 47,5h**



**163,00**  
3.5 / 0,02

## P-73/93-SX PORTA 300 SINISTRA

08430301 **EN** Left door 300 • **DE** Linke tür 300 • **FR** Porte gauche 300 • **ES** Puerta izquierda 300  
**cm. 29,5x 2,5x 47,5h**

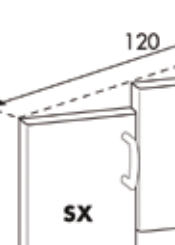

**157,00**  
3 / 0,01

## P-74/94-SX PORTA 400 SINISTRA

08430401 **EN** Left door 400 • **DE** Linke tür 400 • **FR** Porte gauche 400 • **ES** Puerta izquierda 400  
**cm. 39,5x 2,5x 47,5h**

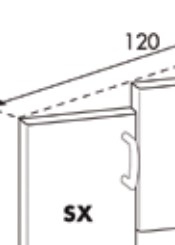

**163,00**  
3.5 / 0,02

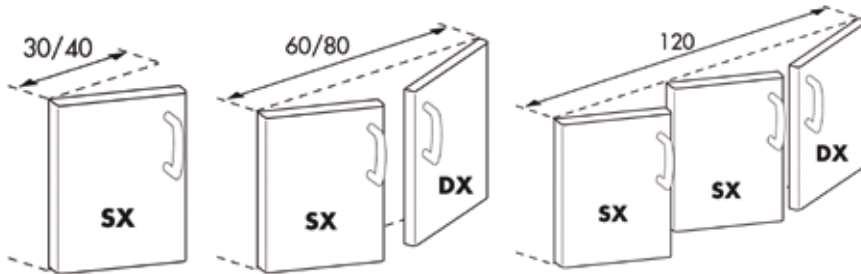

**C-73/93**  
08440320

## CASSETTIERA 300 N. 2 CASSETTI CON 2 BACINELLE INOX, GUIDE TELESCOPICHE. SOLO SU PL

**EN** Drawer set 300 N. 2 drawers with 2 inox containers, telescopic guides. Only for PL • **DE** Schubladen 300 - N. 2 Schubladen mit 2 Chromnickelstahlbehältern, Teleskopeinführungen. Nur für PL • **FR** Tiroirs pour meuble de 300 N. 2 tiroirs avec 2 bacs inox, guides télescopiques. Seulement pour PL • **ES** Cajonera 300 - N. 2 cajones con 2 contenedores de acero inox, guías telescópicas. Solo para PL  
**cm. 29,5x 59x 47,5h**



**611,00**  
16 / 0,19

**C-74/94**  
08440420

## CASSETTIERA 400 - N. 2 CASSETTI CON 2 BACINELLE GN 1/1 15H IN PLASTICA, GUIDE TELESCOPICHE. SOLO SU PL

**EN** Drawer set 400 - N. 2 drawers with 2 GN 1/1 15h plastic containers, telescopic guides. Only for PL • **DE** Schubladen - N. 2 Schubladen mit 2 GN 1/1 15h Kunststoffbehältern, Teleskopeinführungen. Nur für PL • **FR** Tiroirs pour meuble de 400 - N. 2 tiroirs avec 2 bacs en plastique GN 1/1 15h, guides télescopiques. Seulement pour PL • **ES** Cajonera 400 - N. 2 cajones con 2 contenedores GN 1/1 15h de plástico, guías telescópicas. Solo para PL  
**cm. 39,5x 59x 47,5h**



**627,00**  
18 / 0,19

MOD. \_\_\_\_\_  
COD. \_\_\_\_\_

DESCRIZIONE/DESCRIPTION/BEZEICHNUNG/DESCRIPTION/DESCRIPCIÓN  
DIMENSIONI/DIMENSIONS/ABMESSUNGEN/DIMENSIONS/DIMENSIONES

POTENZA/POWER/LEISTUNG/PUISSANCE/POTENCIA  
VOLTAGGIO/VOLTAGE/SPANNUNG/VOLTAGE/VOLTAJE

⚡ kW kcal/h  
⚡ kw V~ Hz

PREZZO/PRICE €  
PREIS/PRIX/PRECIO €  
KG / M<sup>3</sup>

**C-76/96**  
08440620

**CASSETTIERA 600 N. 2 CASSETTI CON 2 BACINELLE INOX, GUIDE TELESCOPICHE. SOLO SU PL**

**EN** Drawer set 600 N. 2 drawers with 2 inox containers, telescopic guides. Only for PL • **DE** Schubladen 600 - N. 2 Schubladen mit 2 Chromnickelstahlbehältern, Telescopeinführungen. Nur für PL • **FR** Tiroirs pour meuble de 600 N. 2 tiroirs avec 2 bacs inox, guides télescopiques. Seulement pour PL • **ES** Cajonera 600 - N. 2 cajones con 2 contenedores de acero inox, guías telescópicas. Solo para PL  
**cm. 59,5x 59x 47,5h**



**867,00**  
22 / 0,28

**C-78/98**  
08440820

**CASSETTIERA 800 - N. 2 CASSETTI CON 4 BACINELLE GN 1/1 15H IN PLASTICA, GUIDE TELESCOPICHE. SOLO SU PL**

**EN** Drawer set 800 - N. 2 drawers with 4 GN 1/1 15h plastic containers, telescopic guides. Only for PL • **DE** Schubladen 800 - N. 2 Schubladen mit 4 GN 1/1 15h Kunststoffbehältern, Telescopeinführungen. Nur für PL • **FR** Tiroirs pour meuble de 800 - N. 2 tiroirs avec 4 bacs en plastique GN 1/1 15h, guides télescopiques. Seulement pour PL • **ES** Cajonera 800 - N. 2 cajones con 4 contenedores GN 1/1 15h de plástico, guías telescópicas. Solo para PL  
**cm. 79,5x 59x 47,5h**



**883,00**  
26 / 0,37

**D-9**  
09470000

**DIVISORIO**

**EN** Spacer • **DE** Trennwand • **FR** Separation • **ES** Divisorio  
**cm. 5x 79x 45h**

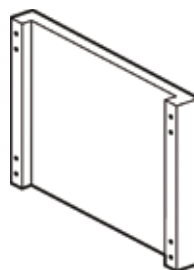

**174,00**  
2.5 / 0,03

**531070300 CESTO 1/1 PER CP-94/98 & CPB-98**

**EN** Basket 1/1 for CP-94/98 & CPB-98 • **DE** Korb 1/1 für CP-94/98 & CPB-98 • **FR** Panier 1/1 pour CP-94/98 & CPB-98 • **ES** Cesta 1/1 para CP-94/98 & CPB-98  
**cm. 28x 49x 21,5h**



**198,00**  
3,5 / 0,08

**531070200 CESTO 2/3 PER CP-94/98 & CPB-98**

**EN** Basket 2/3 for CP-94/98 & CPB-98 • **DE** Korb 2/3 für CP-94/98 & CPB-98 • **FR** Panier 2/3 pour CP-94/98 & CPB-98 • **ES** Cesta 2/3 para CP-94/98 & CPB-98  
**cm. 28x 32x 21,5h**



**136,00**  
2 / 0,06

**531070100 CESTO 1/2 PER CP-94/98 & CPB-98**

**EN** Basket 1/2 for CP-94/98 & CPB-98 • **DE** Korb 1/2 für CP-94/98 & CPB-98 • **FR** Panier 1/2 pour CP-94/98 & CPB-98 • **ES** Cesta 1/2 para CP-94/98 & CPB-98  
**cm. 28x 24x 21,5h**



**124,00**  
1 / 0,05

# ACCESSORI CUOCIPASTA

MOD. \_\_\_\_\_  
COD. \_\_\_\_\_

DESCRIZIONE/DESCRIPTION/BEZEICHNUNG/DESCRIPTION/DESCRIPCIÓN  
DIMENSIONI/DIMENSIONS/ABMESSUNGEN/DIMENSIONS/DIMENSIONES

POTENZA/POWER/LEISTUNG/PUISSANCE/POTENCIA  
VOLTAGGIO/VOLTAGE/SPANNUNG/VOLTAGE/VOLTAJE

⚡ kW kcal/h  
⚡ kw V~ Hz

PREZZO/PRICE €  
PREIS/PRIX/PRECIO €  
KG / M<sup>3</sup>

**531047900 CESTO 1/3 PER CP-94/98 & CPB-98**  
EN Basket 1/3 for CP-94/98 & CPB-98 • DE Korb 1/3 für CP-94/98 & CPB-98 • FR Panier 1/3 pour CP-94/98 & CPB-98 • ES Cesta 1/3 para CP-94/98 & CPB-98  
cm. 28x 16x 21,5h



**98,00**  
1.5 / 0,04

**531048000 CESTO 1/6 PER CP-94/98 & CPB-98**  
EN Basket 1/6 for CP-94/98 & CPB-98 • DE Korb 1/6 für CP-94/98 & CPB-98 • FR Panier 1/6 pour CP-94/98 & CPB-98 • ES Cesta 1/6 para CP-94/98 & CPB-98  
cm. 13,5x 16x 21,5h



**75,00**  
1 / 0,02

**CEA 09580010 COLONNINA EROGAZIONE ACQUA**  
EN Pillar tap • DE Mischbatterie • FR Colonne de distribution eau • ES Rubinetto dispensador de agua



**340,00**  
6 / 0,05

**CEAT 19580010 COLONNINA EROGAZIONE ACQUA TOP**  
EN Pillar tap top • DE Mischbatterie top • FR Colonne de distribution eau top • ES Rubinetto dispensador de agua top

**340,00**  
5 / 0,04

**531047100 GRIGLIA IN TONDINO 2 FUOCHI (SERIE 90)**  
EN grid rod 2 burner (90 line) • DE Gitterstab 2 Brenner (90. Serie) • FR tige grille 2 feux (serie 90) • ES red de varilla 2 quemador (serie 90)

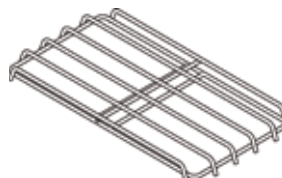

**170,00**  
9 / 0,03

**09570401 GRIGLIA TONDINO PER CW (SERIE 90)**  
EN Grid for CW (90 line) • DE Gitter für CW (90. Serie) • FR Grille ronde pour CW (serie 90) • ES Rejilla para CW (serie 90)  
cm. 36x 68

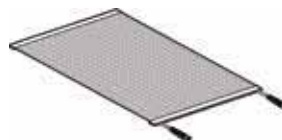

**447,00**  
12 / 0,03

**09570402 GRIGLIA TEGOLO V PER CW (SERIE 90)**  
EN Grid V for CW (90 line) • DE Gitter V für CW (90. Serie) • FR Grille V pour CW (serie 90) • ES Rejilla V para CW (serie 90)  
cm. 36x 68

**447,00**  
12 / 0,03

**544023800 RASCHIETTO PER PIASTRA RIGATA**  
EN Scraper for gooved plate • DE Schaber für gerillte Kochplatte • FR Racloir pour plaque nervurée • ES Rasqueta para placa ranurada



**50,00**  
/ 1,00



Le immagini presentate non sono vincolanti. La ditta si riserva di apportare modifiche senza preavviso. • The pictures are purely representative. The manufacturer reserves the right to modify the technical data and models without previous notice. • Les images

**LO**

présentées ne nous engagent pas. La Société se réserve le droit d'apporter tout modification sans préavis. • Die dargestellten Abbildungen sind nicht verbindlich. Technische Änderungen vorbehalten. • Las imágenes presentadas no son vinculantes. El Fabricante se reserva el derecho de modificar sus productos sin previo aviso.

01/20

**297**

**90**

# ACCESSORI FRY-TOP

MOD. \_\_\_\_\_  
COD. \_\_\_\_\_

DESCRIZIONE/DESCRIPTION/BEZEICHNUNG/DESCRIPTION/DESCRIPCIÓN  
DIMENSIONI/DIMENSIONS/ABMESSUNGEN/DIMENSIONS/DIMENSIONES

POTENZA/POWER/LEISTUNG/PUISSANCE/POTENCIA  
VOLTAGGIO/VOLTAGE/SPANNUNG/VOLTAGE/VOLTAJE

↓ kW kcal/h  
↑ kw V~ Hz

PREZZO/PRICE €  
PREIS/PRIX/PRECIO €  
KG / M<sup>3</sup>

**531040800 RASCHIETTO PER PIASTRA LISCIA CROMATA**  
**EN** Scraper for smooth chromed plate • **DE** Schaber für glatte verchromte Platte • **FR** Racloir pour plaque lisse au chrome • **ES** Rasqueta para placa lisa cromada



**47,00**  
/ 1,00

**531040900 KIT 10 LAME PER RASCHIETTO**  
**EN** 10 blades kit for scraper • **DE** Kit 10 Klingen für Schaber • **FR** Kit de 10 lames pour racloir • **ES** Kit de 10 cuchillas para rasqueta

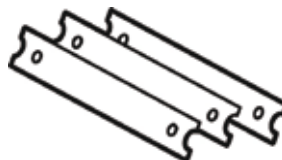

**33,00**  
/ 0,00

**T-FT 09580060 TAPPO PER FRY-TOP**  
**EN** stopper for Fry-top • **DE** Stopfen griddleplatte • **FR** bouchon pour Plaque • **ES** tapón Fry-top  
**cm. 10x 2x 5h**

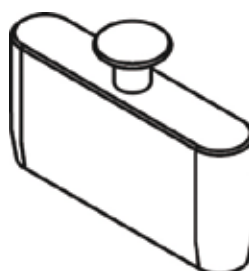

**198,00**  
/ 0,00

**PFT-94 09620400 KIT PROTEZIONE FRONTALE PIANO FRY-TOP**  
**EN** KIT front protection plan fry-top • **DE** Schutz-kit vorne Plan griddleplatte • **FR** KIT protection avant plan plaque • **ES** KIT de protección frontal plan de fry-top  
**cm. 35x 11x 6h**

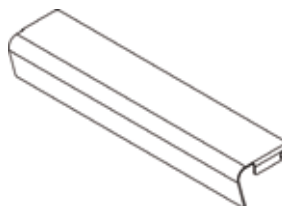

**133,00**  
/ 0,00

**PFT-98 09620800 cm. 75x 11x 6h**

**223,00**  
/ 0,01

**KF-F-ETD S90 546003502 KIT 100 FILTRI 5 MICRON PER F-ETD S90**  
**EN** KIT 100 sieve 5 microns for F-ETD S90 • **DE** KIT 100 Filter 5-Mikron für F-ETD S90 • **FR** KIT 100 filtre 5 microns pour F-ETD S90 • **ES** KIT 100 filtro de 5 micrones para F-ETD S90



**320,00**  
0.1 / 0,00

**531041600 CESTINO 1/2 PER F18-E (STANDARD IN F18-ETD)**  
**EN** Basket 1/2 for F18-E (standard F18-ETD) • **DE** Korb 1/2 zur Friteuse F18-E (standard F18-ETD) • **FR** Panier 1/2 pour F18-E (standard F18-ETD) • **ES** Cesta 1/2 para F18-E (standard F18-ETD)  
**cm. 13,5x 29x 15h**



**62,00**  
0.8 / 0,04

**531041500 CESTINO 1/2 PER F18-90G**  
**EN** Basket 1/2 for F18-90G • **DE** Korb 1/2 für Friteuse F18-90G • **FR** Panier 1/2 pour F18-90G • **ES** Cesta 1/2 para F18-90G  
**cm. 10x 45x 15h**



**62,00**  
0.8 / 0,04



# ACCESSORI FRIGGITRICI

MOD. \_\_\_\_\_  
COD. \_\_\_\_\_

DESCRIZIONE/DESCRIPTION/BEZEICHNUNG/DESCRIPTION/DESCRIPCIÓN  
DIMENSIONI/DIMENSIONS/ABMESSUNGEN/DIMENSIONS/DIMENSIONES

POTENZA/POWER/LEISTUNG/PUISSANCE/POTENCIA  
VOLTAGGIO/VOLTAGE/SPANNUNG/VOLTAGE/VOLTAJE

⚡ kW kcal/h  
⚡ kw V~ Hz

PREZZO/PRICE €  
PREIS/PRIX/PRECIO €  
KG / M<sup>3</sup>

**531041400 CESTINO 1/1 PER F25-G/E + F25-ETD**  
EN Basket 1/1 for F25-G/E + F25-ETD • DE Korb 1/1 für Friteuse F25-G/E + F25-ETD • FR Panier 1/1 pour F25-G/E + F25-ETD • ES Cesta 1/1 para F25-G/E + F25-ETD  
cm. 28x 45x 15h



**108,00**  
1.5 / 0,07

**531041300 CESTINO 1/1 PER F18-ETD (STANDARD IN F18-E)**  
EN Basket 1/1 for F18-ETD (standard F18-E) • DE korb 1/1 für F18-ETD (standard F18-E) • FR Panier 1/1 pour F18-ETD (standard F18-E) • ES Cesta 1/1 para F18-ETD (standard F18-E)  
cm. 28x 29x 15h



**68,00**  
1.5 / 0,06

**KITSS-90 09580050 KIT SCIOGLIMENTO STRUTTO, SOLO PER FRIGGITRICI ELETTRICHE A MOBILE.**  
EN Kit for lard melting, only for electric fryers on cabinet  
• DE Satz fuer schmalzschmelzen, nur für elektrische Friteusen mit unterbau • FR Kit de dissolution lard, seulement pour les friteuses électriques sur armoire  
• ES kit de disolución de manteca, sólo para freidoras eléctricas on mueble

⚡ 0,31 KW **100,00**  
/ 0,01

**BF30 09580030 BACINELLA RACCOGLI OLIO CON FILTRO LT. 30 PER FRIGGITRICE**  
EN 30 lts. oil collecting tray - With filter for deep fryer  
• DE Ölauffangwanne mit Filter, 30 Liter, für Friteuse  
• FR Bac de récupération de l'huile Avec filtre 30 lt. pour friteuse • ES Bandeja para aceite con filtro - 30 lt. para freidora  
cm. 29x 29x 37h



**177,00**  
7 / 0,10

**09550400 COPERCHIO PER BRF-94**  
EN Lid for BFR-94 • DE Deckel für BFR-94 • FR Couvercle pour BFR-94 • ES Tapa para BFR-94  
cm. 32x 70x 5h



**113,00**  
2.5 / 0,01

**09550800 COPERCHIO PER BRF-98**  
EN Lid for BFR-98 • DE Deckel für BFR-98 • FR Couvercle pour BFR-98 • ES Tapa para BFR-98  
cm. 72x 70x 5h

**151,00**  
5 / 0,02

**TG-94 09580400 TAGLIERE PLASTICA**  
EN Plastic chopping-board • DE Schneidebrett • FR Plan de découpe • ES Picador de plástico  
cm. 39x 75x 2,5h

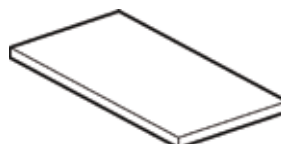

**121,00**  
8 / 0,01

**TG-98 09580800**  
cm. 79x 75x 2,5h

**243,00**  
14 / 0,03



Le immagini presentate non sono vincolanti. La ditta si riserva di apportare modifiche senza preavviso. • The pictures are purely representative. The manufacturer reserves the right to modify the technical data and models without previous notice. • Les images

LO





présentées ne nous engagent pas. La Société se réserve le droit d'apporter tout modification sans préavis. • Die dargestellten Abbildungen sind nicht verbindlich. Technische Änderungen vorbehalten. • Las imágenes presentadas no son vinculantes. El Fabricante se reserva el derecho de modificar sus productos sin previo aviso.

01/20

**299**

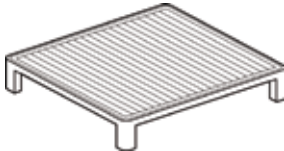
90

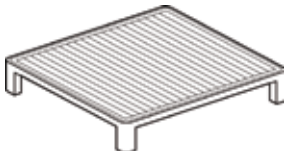
# ACCESSORI

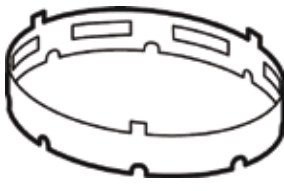
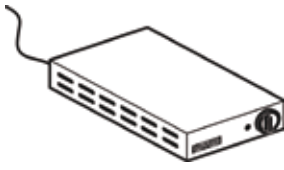
MOD. COD.	DESCRIZIONE/DESCRIPTION/BEZEICHNUNG/DESCRIPTION/DESCRIPCIÓN DIMENSIONI/DIMENSIONS/ABMESSUNGEN/DIMENSIONS/DIMENSIONES	POTENZA/POWER/LEISTUNG/PUISSANCE/POTENCIA VOLTAGGIO/VOLTAGE/SPANNUNG/VOLTAGE/VOLTAJE	⚡ kW kcal/h	⚡ kw V~ Hz	PREZZO/PRICE PREIS/PRIX/PRECIO € KG / M <sup>3</sup>
PLF/9 09590401	<b>PIASTRA LISCIA PER GRIGLIA IN GHISA</b> EN Smooth griddle plate for cast iron grid • DE Fortkochplatte glatt für Gusseisen Rost • FR Plaque lisse pour la grille en fonte • ES Plancha lisa para rejilla de hierro fundido cm. 36x 39				<b>159,00</b> 11 / 0,01
PRF/9 09590403	<b>PIASTRA RIGATA PER GRIGLIA IN GHISA</b> EN Grooved griddle plate for cast iron grid • DE Fortkochplatte gerillt für Gusseisen Rost • FR Plaque nervurée pour la grille en fonte • ES Plancha estriada para rejilla de hierro fundido cm. 36x 39				<b>214,00</b> 11 / 0,01
PLFT/9 09590451	<b>PIASTRA LISCIA PER GRIGLIA IN TONDINO</b> EN Smooth griddle plate for grid rod • DE Fortkochplatte glatt für Gitterstab • FR Plaque lisse pour tige grille • ES Plancha lisa por red de varilla cm. 36x 39				<b>154,00</b> 11 / 0,01
PRFT/9 09590453	<b>PIASTRA RIGATA PER GRIGLIA IN TONDINO</b> EN Grooved griddle plate for grid rod • DE Fortkochplatte gerillt für Gitterstab • FR Plaque nervurée pour tige grille • ES Plancha estriada por red de varilla cm. 36x 39				<b>207,00</b> 11 / 0,01
533009200	<b>GRIGLIA DI RIDUZIONE</b> EN Reduction • DE Reduzierstern • FR Grille de réduction • ES Rejilla de reducción cm. 25x 25				<b>31,00</b> 0.2 / 0,00
KIT-WOK 09580040	<b>KIT WOK - FIAMMA VERTICALE - SOLO SU BRUCIATORE DA 10 KW E GRIGLIE IN GHISA</b> EN KIT WOK - vertical flame - only for 10 kW burner and cast iron grills • DE KIT WOK - vertikaler Flamme - nur 10 kW-Brenner und Roste aus Gusseisen • FR KIT WOK - verticale de la flamme - seulement 10 kW brûleur et grilles en fonte • ES KIT WOK - llama vertical - sólo 10 kW quemador y parrilas de hierro colado cm. Ø 26x 16h				<b>337,00</b> 5 / 0,02
544439900	<b>ANELLO PER WOK - SOLO PER GRIGLIE IN GHISA</b> EN Wok ring - only for cast iron grills • DE Wok Aufsatzring - nur für Roste aus Gusseisen • FR Anneau Wok - seulement pour grilles en fonte • ES Anillo Wok - solo para parrilas de hierro colado cm. Ø22,5x 3,5h				<b>126,00</b> 2 / 0,00
RV 08660410	<b>RISCALDANTE VANO CUCINA</b> EN Heater for range's cabinet • DE Heizer für Herden-Schränkelement • FR Réchauffeur pour armoire du fourneau • ES Calefacción para armario neutro de la cocina cm. 32x 48,5x 8h			⚡ 0,75 kW 230V~ 50/60 Hz	<b>721,00</b> 8 / 0,08

MOD. \_\_\_\_\_  
COD. \_\_\_\_\_

DESCRIZIONE/DESCRIPTION/BEZEICHNUNG/DESCRIPTION/DESCRIPCIÓN  
DIMENSIONI/DIMENSIONS/ABMESSUNGEN/DIMENSIONS/DIMENSIONES

POTENZA/POWER/LEISTUNG/PUISSANCE/POTENCIA  
VOLTAGGIO/VOLTAGE/SPANNUNG/VOLTAGE/VOLTAJE

$\frac{kW}{kcal/h}$   $\frac{V}{Hz}$

PREZZO/PRICE €  
PREIS/PRIX/PRECIO €  
KG / M<sup>3</sup>

**RCRV-94**  
09450402

**RIPIANO FORATO IN APPOGGIO PER RISCALDANTE SU VANO CUCINA**

**EN** Perforated shelf for heater element mod.RV for cooker cabinet • **DE** regale Gelocht für Heizer mod. RV für Herden-Schränkelement • **FR** Étagère perforées pour réchauffeur mod.RV pour armoire du fourneau • **ES** estante perforado para elemento de calefaccion mod.RV para armario neutro de la cocina  
**cm. 34x 75x 10h**



**377,00**  
/

**RRV-94**  
09450401

**RIPIANO FORATO IN APPOGGIO PER RISCALDANTE**

**EN** Perforated shelf for heater element mod.RV • **DE** regale Gelocht für Heizer mod.RV • **FR** Étagère perforées pour réchauffeur mod.RV • **ES** estante perforado para elemento de calefaccion mod.RV  
**cm. 34x 77x 10h**

**377,00**  
/

**RRV-96**  
09450601

**cm. 54x 77x 10h**

**657,00**  
/

**RRV-98**  
09450801

**cm. 74x 77x 10h**

**721,00**  
/

**RRV-910**  
09451001

**cm. 94x 77x 10h**

**1.021,00**  
/

**RRV-912**  
09451201

**cm. 114x 77x 10h**

**1.225,00**  
/

**RRV-916**  
09451601

**cm. 154x 77x 10h**

**1.669,00**  
/

**PT-74/94**  
08460002

**PORTATEGLIE VANO 400 (GN-1/1) VANO 600 (GN-2/1) 4 RIPIANI INT. 7 CM.**

**EN** Frame for plates 400 (GN-1/1) 600 (GN-2/1) - N. 4 shelves, wheel-base 7 cm. • **DE** Auflangeschienen für bleche 400 (GN-1/1) 600 (GN-2/1) - N. 4 Etagen, Abstand 7 cm. • **FR** Kit porte-plaques 400 (GN-1/1) 600 (GN-2/1) - N. 4 étagères; 7 cm. • **ES** Portacazuelas 400 (GN-1/1) 600 (GN-2/1) - N. 4 estantes, int. 7 cm.

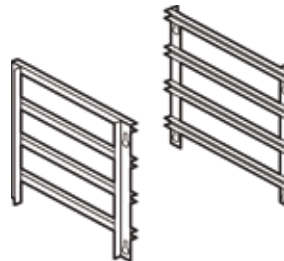

**340,00**  
2.5 / 0,01

**PT-78/98**  
08460012

**PORTATEGLIE VANO 800 (GN-2/1) 4 RIPIANI INT. 7 CM.**

**EN** Frame for plates 800 (GN-2/1) 4 Etagen, Abstand 7 cm. • **DE** Auflangeschienen für bleche 800 (GN-2/1) N. 4 Etagen, Abstand 7 cm. • **FR** Kit porte-plaques 800 (GN-2/1) - N. 4 étagères; 7 cm. • **ES** Portacazuelas 800 (GN-2/1) - N. 4 estantes, int. 7 cm.

**453,00**  
4 / 0,01

**09610400**

**MITRA 400**

**EN** Chimney jack 400 • **DE** Lüftungsaufsatz 400 • **FR** Mitre 400 • **ES** Caperuza 400  
**cm. 40x 7x 92h**

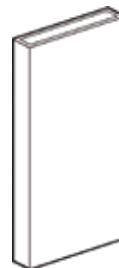

**320,00**  
8 / 0,02

# ACCESSORI

MOD. COD.	DESCRIZIONE/DESCRIPTION/BEZEICHNUNG/DESCRIPTION/DESCRIPCIÓN DIMENSIONI/DIMENSIONS/ABMESSUNGEN/DIMENSIONS/DIMENSIONES	POTENZA/POWER/LEISTUNG/PUISSANCE/POTENCIA VOLTAGGIO/VOLTAGE/SPANNUNG/VOLTAGE/VOLTAJE	↓ kcal/h ↑ kw V~ Hz	PREZZO/PRICE € PREIS/PRIX/PRECIO € KG / M <sup>3</sup>
09610800	<b>MITRA 800</b> EN Chimney jack 800 • DE Lüftungsaufsatz 800 • FR Mitre 800 • ES Caperuza 800 cm. 80x 7x 92h			<b>467,00</b> 16 / 0,04
09611200	<b>MITRA 1200</b> EN Chimney jack 1200 • DE Lüftungsaufsatz 1200 • FR Mitre 1200 • ES Caperuza 1200 cm. 120x 7x 92h			<b>625,00</b> 24 / 0,06
09610402	<b>MITRA 400 PER CPP-94G</b> EN Chimney jack 400 for CPP-94G • DE Lüftungsaufsatz 400 für CPP-94G • FR Mitre 400 pour CPP-94G • ES Caperuza 400 para CPP-94G cm. 40x 7x 73h			<b>467,00</b> 8 / 0,02
09610401	<b>CAMINO ANTIVENTO 400</b> EN Draught diverter 400 • DE Strömungssicherung 400 • FR Cheminee anti-vent 400 • ES Chimenea contra viento 400 cm. 40x 19x 120h			<b>561,00</b> 8 / 0,08
09610801	<b>CAMINO ANTIVENTO 800</b> EN Draught diverter 800 • DE Strömungssicherung 800 • FR Cheminee anti-vent 800 • ES Chimenea contra viento 800 cm. 80x 19x 120h			<b>657,00</b> 16 / 0,15
09611201	<b>CAMINO ANTIVENTO 1200</b> EN Draught diverter 1200 • DE Strömungssicherung 1200 • FR Cheminee anti-vent 1200 • ES Chimenea contra viento 1200 cm. 120x 19x 120h			<b>867,00</b> 24 / 0,25
09610403	<b>CAMINO ANTIVENTO 400 PER CPP-94G</b> EN Draught diverter 400 for CPP-94G • DE Strömungssicherung 400 für CPP-94G • FR Cheminee anti-vent 400 pour CPP-94G • ES Chimenea contra viento 400 para CPP-94G cm. 40x 19x 98h			<b>561,00</b> 8 / 0,08
SA-72/92 08600200	<b>SCHIENA POSTERIORE A VISTA PER APPARECCHI</b> EN Back cover • DE Rückenwand • FR Dos de finition • ES panel posterior cm. 20x 1,5x 81h			<b>83,00</b> 2 / 0,01
SA-73/93 08600300	cm. 30x 1,5x 81h			<b>94,00</b> 3 / 0,01
SA-74/94 08600400	cm. 40x 1,5x 81h			<b>108,00</b> 3 / 0,01
SA-75/95 08600500	cm. 50x 1,5x 81h			<b>135,00</b> 4 / 0,01
SA-76/96 08600600	cm. 60x 1,5x 81h			<b>156,00</b> 4 / 0,02

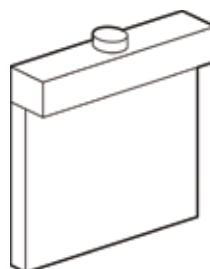

# ACCESSORI

MOD. \_\_\_\_\_ DESCRIZIONE/DESCRIPTION/BEZEICHNUNG/DESCRIPTION/DESCRIPCIÓN POTENZA/POWER/LEISTUNG/PUISSANCE/POTENCIA ⚡kW ⚡kw PREZZO/PRICE €  
 COD. \_\_\_\_\_ DIMENSIONI/DIMENSIONS/ABMESSUNGEN/DIMENSIONS/DIMENSIONES VOLTAGGIO/VOLTAGE/SPANNUNG/VOLTAGE/VOLTAJE kcal/h V~ / Hz PREIS/PRIX/PRECIO €  
 KG / M<sup>3</sup>

<b>SA-77/97</b> 08600700	<b>cm. 70x 1,5x 81h</b>		<b>167,00</b> 5 / 0,02
<b>SA-78/98</b> 08600800	<b>cm. 80x 1,5x 81h</b>		<b>183,00</b> 5 / 0,02
<b>SA-79/99</b> 08600900	<b>cm. 90x 1,5x 81h</b>		<b>205,00</b> 6 / 0,02
<b>SA-710/910</b> 08601000	<b>cm. 100x 1,5x 81h</b>		<b>228,00</b> 6 / 0,03
<b>SA-711/911</b> 08601100	<b>cm. 110x 1,5x 81h</b>		<b>251,00</b> 7 / 0,03
<b>SA-712/912</b> 08601200	<b>cm. 120x 1,5x 81h</b>		<b>274,00</b> 7 / 0,03
<b>SA-713/913</b> 08601300	<b>cm. 130x 1,5x 81h</b>		<b>297,00</b> 8 / 0,03
<b>SA-714/914</b> 08601400	<b>cm. 140x 1,5x 81h</b>		<b>319,00</b> 8 / 0,04
<b>SA-715/915</b> 08601500	<b>cm. 150x 1,5x 81h</b>		<b>342,00</b> 10 / 0,04
<b>SA-716/916</b> 08601600	<b>cm. 160x 1,5x 81h</b>	<b>365,00</b> 10 / 0,04	
<b>SA-94CPPG</b> 08600402	<b>SCHIENA POSTERIORE A VISTA PER CUOCIPASTA GAS CPP-94G</b> <b>EN</b> Back cover for Gas pasta cooker CPP-94G • <b>DE</b> Ruckenwand für Gas-Nudelkocher CPP-94G • <b>FR</b> Dos de finition pour Cuiseur a pates gaz CPP-94G • <b>ES</b> panel posterior para Cuece pasta gas CPP-94G <b>cm. 40x 1,5x 100h</b>		<b>125,00</b> 3 / 0,01
<b>SA-98CPPG</b> 08600802	<b>SCHIENA POSTERIORE A VISTA PER CUOCIPASTA GAS CPP-98G</b> <b>EN</b> Back cover for Gas pasta cooker CPP-98G • <b>DE</b> Ruckenwand für Gas-Nudelkocher CPP-98G • <b>FR</b> Dos de finition pour Cuiseur a pates gaz CPP-98G • <b>ES</b> panel posterior para Cuece pasta gas CPP-98G <b>cm. 80x 1,5x 100h</b>		<b>199,00</b> 6 / 0,03

**KIT-TOPM-SA KIT TAMPONAMENTI LATERALI PER SCHIENA POSTERIORE MONTATA SU APPARECCHI TOP E MOBILI "M-.."**

08600001 **EN** Side KIT for back cover mounted on the TOP machine and Stand "M-.." • **DE** Seitliches KIT für Ruckenwand montiert auf der TOP-Maschine und Unterbau "M-.." • **FR** KIT latéral pour Dos de finition monté sur la machine TOP et Placard "M-.." • **ES** KIT lateral para panel posteriore montado en la máquina TOP y Mueble base "M-.."

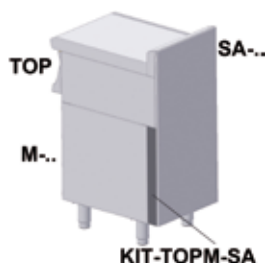

**73,00**  
1 / 0,01



MOD. \_\_\_\_\_  
COD. \_\_\_\_\_

DESCRIZIONE/DESCRIPTION/BEZEICHNUNG/DESCRIPTION/DESCRIPCIÓN  
DIMENSIONI/DIMENSIONS/ABMESSUNGEN/DIMENSIONS/DIMENSIONES

POTENZA/POWER/LEISTUNG/PUISSANCE/POTENCIA  
VOLTAGGIO/VOLTAGE/SPANNUNG/VOLTAGE/VOLTAJE

⚡ kcal/h  
⚡ kw  
V~  
Hz

PREZZO/PRICE €  
PREIS/PRIX/PRECIO €  
KG / M<sup>3</sup>

**TPC-9**  
09560002

**TESTATA CHIUSURA PER CF-PC-TP (SOLO GAS)  
(IN DOTAZIONE 1 PEZZO PER APPARECCHIO)**  
**EN** Head end filler strip for CF-PC-TP (Gas only) (1 piece included in each machine) • **DE** Abschluss-Element für CF-PC-TP (nur gas) (1 Stück in jeder Maschine enthalten) • **FR** Élément de jonction pour CF-PC-TP (seulement gaz) (1 pièce incluse dans chaque machine) • **ES** Chapa de cierre para CF-PC-TP (solo gas) (1 pieza incluida en cada equipo)  
**cm. 0,2x 70,5**



**57,00**  
1 / 0,00

**TPA-9**  
09560001

**TESTATA CHIUSURA PER TUTTI GLI ALTRI  
MODELLI (IN DOTAZIONE 1 PEZZO PER  
APPARECCHIO)**  
**EN** Head end filler strip for all other models (1 piece included in each machine) • **DE** Abschluss-Element für alle anderen Modelle (1 Stück in jeder Maschine enthalten) • **FR** Élément de jonction pour tous les autres modèles (1 pièce incluse dans chaque machine) • **ES** Chapa de cierre para todos los demás modelos (1 pieza incluida en cada equipo)  
**cm. 0,2x 70,5**



**57,00**  
1 / 0,00

**TMA-95X**  
09540901

**TESTATA 1 LATO SERIE 90 SINISTRA**  
**EN** Head 1 side S90 left • **DE** Abschluss element 1 seite S90 links • **FR** Element de jonction 1 coté S90 gauche • **ES** Embellecedor 1 lado S90 izquierda  
**cm. 0,2x 90**



**218,00**  
10 / 1,00

**TMA-9DX**  
09540900

**TESTATA 1 LATO SERIE 90 DESTRA**  
**EN** Head 1 side S90 right • **DE** Abschluss element 1 seite S90 recht • **FR** Element de jonction 1 coté S90 droit • **ES** Embellecedor 1 lado S90 derecha  
**cm. 0,2x 90**



**218,00**  
10 / 1,00

**TMA-99**  
09549900

**TESTATA 2 LATI SERIE 90**  
**EN** Head 2 sides S90 • **DE** Abschluss element seiten S90 • **FR** Element de jonction 2 cotés S90 • **ES** Embellecedor 2 lados S90  
**cm. 0,2x180**



**435,00**  
20 / 1,00

**TMTA-95X**  
09540921

**TESTATA TAMBURATA 1 LATO SERIE 90  
SINISTRA, CON STESSO PROFILO LINEA  
FRONTALE**  
**EN** Head 1 side S90 left, with the same front line profile • **DE** Abschluss element 1 seite S90 links, mit dem gleichen Frontlinienprofil • **FR** Element de jonction 1 coté S90 gauche, avec le même profil de ligne • **ES** Embellecedor 1 lado S90 izquierda, con el mismo perfil de línea frontal  
**cm. 7,5x 90**



**680,00**  
16 / 1,00

MOD. \_\_\_\_\_  
COD. \_\_\_\_\_

DESCRIZIONE/DESCRIPTION/BEZEICHNUNG/DESCRIPTION/DESCRIPCIÓN  
DIMENSIONI/DIMENSIONS/ABMESSUNGEN/DIMENSIONS/DIMENSIONES

POTENZA/POWER/LEISTUNG/PUISSANCE/POTENCIA  
VOLTAGGIO/VOLTAGE/SPANNUNG/VOLTAGE/VOLTAJE

⚡ kW kcal/h  
⚡ kw V~ Hz

PREZZO/PRICE €  
PREIS/PRIX/PRECIO €  
KG / M<sup>3</sup>

**TMTA-9DX**  
09540920

**TESTATA TAMBURATA 1 LATO SERIE 90  
DESTRA, CON STESSO PROFILO LINEA  
FRONTALE**

**EN** Head 1 side S90 right, with the same front line profile • **DE** Abschluss element 1 seite S90 recht, mit dem gleichen Frontlinienprofil • **FR** Element de jonction 1 coté S90 droit, avec le même profil de ligne • **ES** Embellecedor 1 lado S90 derecha, con el mismo perfil de línea frontal  
**cm. 7,5x 90**



**680,00**  
16 / 1,00

**TMTA-99**  
09549920

**TESTATA TAMBURATA 2 LATI SERIE 90, CON  
STESSO PROFILO LINEA FRONTALE**

**EN** Head 2 sides S90, with the same front line profile • **DE** Abschluss element seiten S90, mit dem gleichen Frontlinienprofil • **FR** Element de jonction 2 cotés S90, avec le même profil de ligne • **ES** Embellecedor 2 lados S90, con el mismo perfil de línea frontal  
**cm. 7,5x 180**



**1.300,00**  
32 / 1,00

**SIA-7/9**  
08480000

**STAFFA INFERIORE UNIONE APPARECCHI  
EN Lower bracket to join two items**

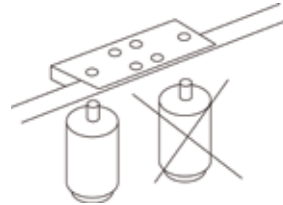

**48,00**  
2 / 0,00

**SR-100**  
50900001

**SET 4 RUOTE Ø 100X30, 2 CON FRENO**

**EN** Set of 4 wheels Ø 100x30, 2 with brake • **DE** 4 Rollen Satz Ø 100x30, 2 davon mit Feststellbremse • **FR** Kit 4 roues Ø 100x30, 2 avec frein • **ES** Equipo 4 ruedas Ø 100x30, 2 con frenos  
**cm. 12,7h**

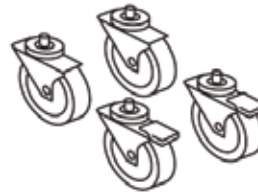

**284,00**  
1 / 0,01

# ACCESSORI

MOD. COD.	DESCRIZIONE/DESCRIPTION/BEZEICHNUNG/DESCRIPTION/DESCRIPCIÓN DIMENSIONI/DIMENSIONS/ABMESSUNGEN/DIMENSIONS/DIMENSIONES	POTENZA/POWER/LEISTUNG/PUISSANCE/POTENCIA VOLTAGGIO/VOLTAGE/SPANNUNG/VOLTAGE/VOLTAJE	$\frac{kW}{kcal/h}$ $\frac{V}{Hz}$	PREZZO/PRICE PREIS/PRIX/PRECIO € KG / M <sup>3</sup>
08570103	<b>MENSOLA ANTERIORE</b> EN Earlier shelf • DE Frühere Regal • FR Plus tôt plateau • ES A principios de la plataforma cm. 30x 21x 5h			<b>324,00</b> / 0,01
08570104	cm. 40x 21x 5h			<b>333,00</b> / 0,01
08570105	cm. 50x 21x 5h			<b>343,00</b> / 0,01
08570106	cm. 60x 21x 5h			<b>352,00</b> / 0,01
08570107	cm. 70x 21x 5h			<b>361,00</b> / 0,01
08570108	cm. 80x 21x 5h			<b>369,00</b> / 0,01
08570109	cm. 90x 21x 5h			<b>380,00</b> / 0,02
08570110	cm. 100x 21x 5h			<b>389,00</b> / 0,02
08570111	cm. 110x 21x 5h			<b>400,00</b> / 0,02
08570112	cm. 120x 21x 5h			<b>410,00</b> / 0,02
08570113	cm. 130x 21x 5h			<b>424,00</b> / 0,02
08570114	cm. 140x 21x 5h			<b>433,00</b> / 0,02
08570115	cm. 150x 21x 5h			<b>447,00</b> / 0,02
08570116	cm. 160x 21x 5h			<b>460,00</b> / 0,03

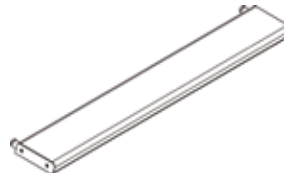

# ACCESSORI

MOD. COD.	DESCRIZIONE/DESCRIPTION/BEZEICHNUNG/DESCRIPTION/DESCRIPCIÓN DIMENSIONI/DIMENSIONS/ABMESSUNGEN/DIMENSIONS/DIMENSIONES	POTENZA/POWER/LEISTUNG/PUISSANCE/POTENCIA VOLTAGGIO/VOLTAGE/SPANNUNG/VOLTAGE/VOLTAJE	$\frac{kW}{kcal/h}$ $\frac{V}{Hz}$	PREZZO/PRICE PREIS/PRIX/PRECIO € KG / M <sup>3</sup>
08570002	<b>CORRIMANO</b> <b>EN</b> HANDRAIL • <b>DE</b> HAND LAUF • <b>FR</b> MAIN COURANTE • <b>ES</b> PASAMANO cm. 20x 7x 4h			<b>271,00</b> / 0,00
08570003	cm. 30x 7x 4h			<b>276,00</b> / 0,00
08570004	cm. 40x 7x 4h			<b>279,00</b> / 0,00
08570005	cm. 50x 7x 4h			<b>287,00</b> / 0,00
08570006	cm. 60x 7x 4h			<b>295,00</b> / 0,00
08570007	cm. 70x 7x 4h			<b>301,00</b> / 0,00
08570008	cm. 80x 7x 4h			<b>306,00</b> / 0,01
08570009	cm. 90x 7x 4h			<b>310,00</b> / 0,01
08570010	cm. 100x 7x 4h			<b>315,00</b> / 0,01
08570011	cm. 110x 7x 4h			<b>324,00</b> / 0,01
08570012	cm. 120x 7x 4h			<b>333,00</b> / 0,01
08570013	cm. 130x 7x 4h			<b>344,00</b> / 0,01
08570014	cm. 140x 7x 4h			<b>356,00</b> / 0,01
08570015	cm. 150x 7x 4h			<b>388,00</b> / 0,01
08570016	cm. 160x 7x 4h			<b>420,00</b> / 0,01



533116300	<b>GIUNZIONE CORRIMANO</b> <b>EN</b> junction handrail • <b>DE</b> Gelenk Hand lauf • <b>FR</b> Main courante de l'embranchement • <b>ES</b> conexión pasamano cm. Ø 3x 2,4			<b>43,00</b> / 1,00
-----------	---	--	--	------------------------



MOD. \_\_\_\_\_  
COD. \_\_\_\_\_

DESCRIZIONE/DESCRIPTION/BEZEICHNUNG/DESCRIPTION/DESCRIPCIÓN  
DIMENSIONI/DIMENSIONS/ABMESSUNGEN/DIMENSIONS/DIMENSIONES

POTENZA/POWER/LEISTUNG/PUISSANCE/POTENCIA  
VOLTAGGIO/VOLTAGE/SPANNUNG/VOLTAGE/VOLTAJE

⚡ kW kcal/h  
⚡ kW V~ Hz

PREZZO/PRICE €  
PREIS/PRIX/PRECIO €  
KG / M<sup>3</sup>

**ZB**  
01410000

**ZOCCOLATURA BASE**  
**EN** FRONT PLINTH • **DE** GRUNDSOCKEL • **FR**  
PLINTHE FRONTAL • **ES** ZOCOLOS BASE  
**€/m x cm. 15h**

**113,00**  
/

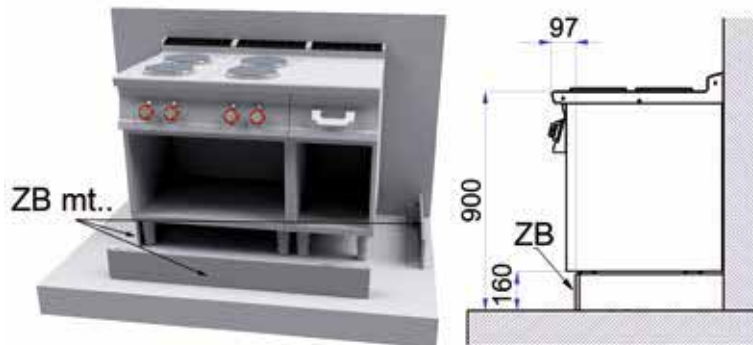

**FZ-9**  
09480001

**ZOCCOLATURA LATERALE - KIT**  
**EN** side plinth - kit • **DE** seitensockel - kit • **FR** plinthe  
lateral - kit • **ES** zocolos lateral - kit  
**cm. 1,5x 80x 6h**

**240,00**  
/



**CZ-72/92**  
08480002

**KIT CASSETTO ZOCCOLO, INCLUSI 4 PIEDINI**  
**EN** drawer clog - kit (4 small feet included) • **DE**  
schubladen sockel - kit (4 kleine FüÙe enthalten) • **FR**  
tiroir plinthe - kit (4 petits pieds inclus) • **ES** cajon  
zocolos - kit (4 pies pequeno incluido)  
**cm. 20x 61x 5,5h**

**137,00**  
3 / 0,01



**CZ-93**  
09480003

**cm. 30x 81x 5,5h**

**188,00**  
4 / 0,02

**CZ-94**  
09480004

**cm. 40x 81x 5,5h**

**212,00**  
4.5 / 0,03

**CZ-96**  
09480006

**cm. 60x 81x 5,5h**

**264,00**  
5.5 / 0,04

**CZ-98**  
09480008

**cm. 80x 81x 5,5h**

**325,00**  
7.5 / 0,06

**CZ-912**  
09480012

**cm. 120x 81x 5,5h**

**446,00**  
8.5 / 0,08

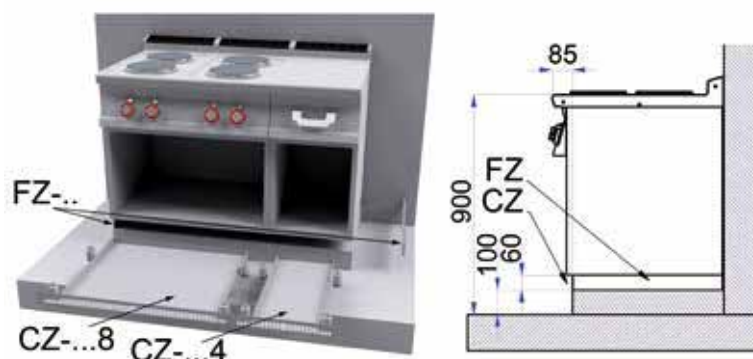



# ACCESSORI

MOD. \_\_\_\_\_  
COD. \_\_\_\_\_

DESCRIZIONE/DESCRIPTION/BEZEICHNUNG/DESCRIPTION/DESCRIPCIÓN  
DIMENSIONI/DIMENSIONS/ABMESSUNGEN/DIMENSIONS/DIMENSIONES

POTENZA/POWER/LEISTUNG/PUISSANCE/POTENCIA  
VOLTAGGIO/VOLTAGE/SPANNUNG/VOLTAGE/VOLTAJE

⚡ kW kcal/h  
⚡ kW V~ Hz

PREZZO/PRICE €  
PREIS/PRIX/PRECIO €  
KG / M<sup>3</sup>

**PLT-92**  
19010200

**PIANO LAVORO (INCLUSA 1 TESTATA CHIUSURA PIANO MOD.TPA-9)**  
**EN** Worktop (included 1 Head end filler strip mod.TPA-9) • **DE** Arbeitsplatte (inbegriffen 1 Abschluss-Element mod.TPA-9) • **FR** Plan de travail (inclus 1 Élément de jonction top mod.TPA-9) • **ES** Sobre de trabajo (incluida 1 Chapa de cierre para top mod.TPA-9)  
**cm. 20x 90x 28h**



**539,00**  
18 / 0,23

**PLST-93**  
19010301

**cm. 30x 90x 28h**



**559,00**  
22 / 0,23

**PLST-94**  
19010401

**cm. 40x 90x 28h**



**570,00**  
23 / 0,23

**PLST-96**  
19010601

**cm. 60x 90x 28h**



**918,00**  
29 / 0,33

**PLST-98**  
19010801

**cm. 80x 90x 28h**



**1.021,00**  
35 / 0,44

**PLT-93**  
19010300

**PIANO LAVORO CASSETTO 19X50X15H INOX (INCLUSA 1 TESTATA CHIUSURA PIANO MOD. TPA-9)**  
**EN** Worktop - Drawer cm. 19x50x15h (included 1 Head end filler strip mod.TPA-9) • **DE** Arbeitsplatte - Schublade cm. 19x50x15h (inbegriffen 1 Abschluss-Element mod.TPA-9) • **FR** Plan de travail - Tiroir inox cm. 19x50x15h (inclus 1 Élément de jonction top mod.TPA-9) • **ES** Sobre de trabajo. Cajón cm. 19x50x15h inox (incluida 1 Chapa de cierre para top mod.TPA-9)  
**cm. 30x 90x 28h**



**792,00**  
25 / 0,23

MOD. \_\_\_\_\_  
COD. \_\_\_\_\_

DESCRIZIONE/DESCRIPTION/BEZEICHNUNG/DESCRIPTION/DESCRIPCIÓN  
DIMENSIONI/DIMENSIONS/ABMESSUNGEN/DIMENSIONS/DIMENSIONES

POTENZA/POWER/LEISTUNG/PUISSANCE/POTENCIA  
VOLTAGGIO/VOLTAGE/SPANNUNG/VOLTAGE/VOLTAJE

⚡ kW kcal/h  
⚡ kw V~ Hz

PREZZO/PRICE €  
PREIS/PRIX/PRECIO €  
KG / M<sup>3</sup>

**PLT-94**  
19010400

**PIANO LAVORO CASSETTO CON 1 BACINELLA GN 1/1 15H PLASTICA (INCLUSA 1 TESTATA CHIUSURA PIANO MOD.TPA-9)**

**EN** Worktop - Drawer with 1 plastic container GN 1/1 15h (included 1 Head end filler strip mod.TPA-9)  
• **DE** Arbeitsplatte - Schublade mit 1 GN 1/1 15h Kunststoffbehälter (inbegriffen 1 Abschluss-Element mod.TPA-9) • **FR** Plan de travail - Tiroir avec bac en plastique GN 1/1 15h (inclus 1 Élément de jonction top mod.TPA-9) • **ES** Sobre de trabajo Cajón con 1 contenedor GN 1/1 15h plástico (incluida 1 Chapa de cierre para top mod.TPA-9)  
**cm. 40x 90x 28h**



**761,00**  
28 / 0,23

**PLT-96**  
19010600

**PIANO LAVORO CASSETTO 49X50X15H INOX (INCLUSA 1 TESTATA CHIUSURA PIANO MOD.TPA-9)**

**EN** Worktop - Drawer cm. 49x50x15h (included 1 Head end filler strip mod.TPA-9) • **DE** Arbeitsplatte - Schublade cm. 49x50x15h (inbegriffen 1 Abschluss-Element mod.TPA-9) • **FR** Plan de travail - Tiroir inox cm. 49x50x15h (inclus 1 Élément de jonction top mod.TPA-9) • **ES** Sobre de trabajo. Cajón cm. 49x50x15h inox (incluida 1 Chapa de cierre para top mod.TPA-9)  
**cm. 60x 90x 28h**



**1.131,00**  
38 / 0,33

**PLT-98**  
19010800

**PIANO LAVORO CASSETTO CON 2 BACINELLE GN 1/1 15H PLASTICA (INCLUSA 1 TESTATA CHIUSURA PIANO MOD.TPA-9)**

**EN** Worktop - Drawer with 2 plastic containers GN 1/1 15h (included 1 Head end filler strip mod.TPA-9)  
• **DE** Arbeitsplatte - Schublade mit 2 GN 1/1 15h Kunststoffbehältern (inbegriffen 1 Abschluss-Element mod.TPA-9) • **FR** Plan de travail - Tiroir avec 2 bacs en plastique GN 1/1 15h (inclus 1 Élément de jonction top mod.TPA-9) • **ES** Sobre de trabajo Cajón con 2 contenedores GN 1/1 15h plástico (incluida 1 Chapa de cierre para top mod.TPA-9)  
**cm. 80x 90x 28h**



**1.255,00**  
46 / 0,44

**LAT-94**  
19020400

**LAVELLO RUBINETTO A LEVA - VASCA CM. 30X35X15H (INCLUSA 1 TESTATA CHIUSURA PIANO MOD.TPA-9)**

**EN** Sink unit - Lever type tap - Bowl cm. 30x35x15h (included 1 Head end filler strip mod.TPA-9) • **DE** Spülbecken - Einhebel-Mischarmatur Becken cm. 30x35x15h (inbegriffen 1 Abschluss-Element mod.TPA-9) • **FR** Bac-évier avec robinetterie - Bac cm. 30x35x15h (inclus 1 Élément de jonction top mod.TPA-9) • **ES** Fregadero - Grifo a palanca - Pileta cm. 30x35x15h (incluida 1 Chapa de cierre para top mod.TPA-9)  
**cm. 40x 90x 28h**



**991,00**  
24 / 0,23

**PCT-94ET**  
19030430

**PIANO COTTURA TRIFASE N. 2 PIASTRE (INCLUSA 1 TESTATA CHIUSURA PIANO MOD.TPA-9)**

**EN** Boiling unit threephase - N. 2 plates (included 1 Head end filler strip mod.TPA-9) • **DE** Kochplatte dreiphasig - N. 2 Kochplatten (inbegriffen 1 Abschluss-Element mod.TPA-9) • **FR** Rechaud électriques - N. 2 plaques (inclus 1 Élément de jonction top mod.TPA-9) • **ES** Sobre de cocción trifásico - N. 2 planchas (incluida 1 Chapa de cierre para top mod.TPA-9)  
**cm. 40x 90x 28h**



⚡ 7 kW  
400V~2N  
230V~3  
230V~  
50/60 Hz

**1.151,00**  
29 / 0,23

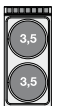

# PIANI COTTURA ELETTRICI - TOP

MOD. \_\_\_\_\_  
COD. \_\_\_\_\_

DESCRIZIONE/DESCRIPTION/BEZEICHNUNG/DESCRIPTION/DESCRIPCIÓN  
DIMENSIONI/DIMENSIONS/ABMESSUNGEN/DIMENSIONS/DIMENSIONES

POTENZA/POWER/LEISTUNG/PUISSANCE/POTENCIA  
VOLTAGGIO/VOLTAGE/SPANNUNG/VOLTAGE/VOLTAJE

⚡ kW \_\_\_\_\_ kcal/h \_\_\_\_\_  
V~ Hz \_\_\_\_\_

PREZZO/PRICE € \_\_\_\_\_  
PREIS/PRIX/PRECIO € \_\_\_\_\_  
KG / M<sup>3</sup> \_\_\_\_\_

**PCT-98ET**  
19030830

**PIANO COTTURA TRIFASE N. 4 PIASTRE (INCLUSA 1 TESTATA CHIUSURA PIANO MOD. TPA-9)**

**EN** Boiling unit threephase - N. 4 plates (included 1 Head end filler strip mod.TPA-9) • **DE** Kochplatte dreiphasig - N. 4 Kochplatten (inbegriffen 1 Abschluss-Element mod.TPA-9) • **FR** Rechaud électriques - N. 4 plaques (inclus 1 Élément de jonction top mod.TPA-9) • **ES** Sobre de cocción trifásico - N. 4 planchas (incluida 1 Chapa de cierre para top mod.TPA-9)  
**cm. 80x 90x 28h**



⚡ 14 kW \_\_\_\_\_ **2.317,00**  
400V~3N \_\_\_\_\_ 68 / 0,44  
50/60 Hz \_\_\_\_\_

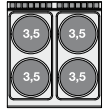

**PCT-912ET**  
19031230

**PIANO COTTURA TRIFASE N. 6 PIASTRE (INCLUSA 1 TESTATA CHIUSURA PIANO MOD. TPA-9)**

**EN** Boiling unit threephase - N. 6 plates (included 1 Head end filler strip mod.TPA-9) • **DE** Kochplatte dreiphasig - N. 6 Kochplatten (inbegriffen 1 Abschluss-Element mod.TPA-9) • **FR** Rechaud électriques - N. 6 plaques (inclus 1 Élément de jonction top mod.TPA-9) • **ES** Sobre de cocción trifásico - N. 6 planchas (incluida 1 Chapa de cierre para top mod.TPA-9)  
**cm. 120x 90x 28h**



⚡ 21 kW \_\_\_\_\_ **3.176,00**  
400V~3N \_\_\_\_\_ 94 / 0,64  
50/60 Hz \_\_\_\_\_



**PCT-916ET**  
19031630

**PIANO COTTURA TRIFASE - N. 8 PIASTRE (INCLUSA 1 TESTATA CHIUSURA PIANO MOD. TPA-9)**

**EN** Boiling unit threephase - N. 8 plates (included 1 Head end filler strip mod.TPA-9) • **DE** Kochplatte dreiphasig - N. 8 Kochplatten (inbegriffen 1 Abschluss-Element mod.TPA-9) • **FR** Rechaud triphase - N. 8 plaques (inclus 1 Élément de jonction top mod.TPA-9) • **ES** Sobre de cocción trifásico - N. 8 planchas (incluida 1 Chapa de cierre para top mod.TPA-9)  
**cm. 160x 90x 28h**



⚡ 28 kW \_\_\_\_\_ **4.072,00**  
400V~3N \_\_\_\_\_ 131 / 0,96  
50/60 Hz \_\_\_\_\_

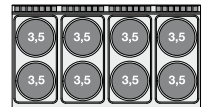

**PCQT-94ET**  
19030431

**PIANO COTTURA TRIFASE - N. 2 PIASTRE QUADRE (INCLUSA 1 TESTATA CHIUSURA PIANO MOD.TPA-9)**

**EN** Boiling unit threephase - N. 2 square plates (included 1 Head end filler strip mod.TPA-9) • **DE** Kochplatte dreiphasig - N. 2 quadratischen Platten (inbegriffen 1 Abschluss-Element mod.TPA-9) • **FR** Rechaud électriques - N. 2 plaques carrés (inclus 1 Élément de jonction top mod.TPA-9) • **ES** Sobre de cocción trifásico - N. 2 planchas cuadradas (incluida 1 Chapa de cierre para top mod.TPA-9)  
**cm. 40x 90x 28h**



⚡ 8 kW \_\_\_\_\_ **1.598,00**  
400V~2N \_\_\_\_\_ 33 / 0,23  
230V~3 \_\_\_\_\_  
230V~ \_\_\_\_\_  
50/60 Hz \_\_\_\_\_



**PCQT-98ET**  
19030831

**PIANO COTTURA TRIFASE - N. 4 PIASTRE QUADRE (INCLUSA 1 TESTATA CHIUSURA PIANO MOD.TPA-9)**

**EN** Boiling unit threephase - N. 4 square plates (included 1 Head end filler strip mod.TPA-9) • **DE** Kochplatte dreiphasig - N. 4 quadratischen Platten (inbegriffen 1 Abschluss-Element mod.TPA-9) • **FR** Rechaud électriques - N. 4 plaques carrés (inclus 1 Élément de jonction top mod.TPA-9) • **ES** Sobre de cocción trifásico - N. 4 planchas cuadradas (incluida 1 Chapa de cierre para top mod.TPA-9)  
**cm. 80x 90x 28h**



⚡ 16 kW \_\_\_\_\_ **2.952,00**  
400V~3N \_\_\_\_\_ 71 / 0,44  
50/60 Hz \_\_\_\_\_



Le immagini presentate non sono vincolanti. La ditta si riserva di apportare modifiche senza preavviso. • The pictures are purely representative. The manufacturer reserves the right to modify the technical data and models without previous notice. • Les images

**LO**

présentées ne nous engagent pas. La Société se réserve le droit d'apporter tout modification sans préavis. • Die dargestellten Abbildungen sind nicht verbindlich. Technische Änderungen vorbehalten. • Las imágenes presentadas no son vinculantes. El Fabricante se reserva el derecho de modificar sus productos sin previo aviso.

01/20

**311**

**90**

# PIANI COTTURA ELETTRICI - TOP

MOD. \_\_\_\_\_  
COD. \_\_\_\_\_

DESCRIZIONE/DESCRIPTION/BEZEICHNUNG/DESCRIPTION/DESCRIPCIÓN  
DIMENSIONI/DIMENSIONS/ABMESSUNGEN/DIMENSIONS/DIMENSIONES

POTENZA/POWER/LEISTUNG/PUISSANCE/POTENCIA  
VOLTAGGIO/VOLTAGE/SPANNUNG/VOLTAGE/VOLTAJE

⚡ kW \_\_\_\_\_  
kcal/h \_\_\_\_\_  
V~ \_\_\_\_\_  
Hz \_\_\_\_\_

PREZZO/PRICE € \_\_\_\_\_  
PREIS/PRIX/PRECIO € \_\_\_\_\_  
KG / M<sup>3</sup> \_\_\_\_\_

**PCQT-912ET PIANO COTTURA TRIFASE - N. 6 PIASTRE QUADRE (INCLUSA 1 TESTATA CHIUSURA PIANO MOD.TPA-9)**

19031231

**EN** Boiling unit threephase - N. 6 square plates (included 1 Head end filler strip mod.TPA-9) • **DE** Kochplatte dreiphasig - N. 6 quadratischen Platten (inbegriffen 1 Abschluss-Element mod.TPA-9) • **FR** Rechaud électriques - N. 6 plaques carrés (inclus 1 Élément de jonction top mod.TPA-9) • **ES** Sobre de cocción trifásico - N. 6 planchas cuadradas (incluida 1 Chapa de cierre para top mod.TPA-9)  
**cm. 120x 90x 28h**



⚡ 24 kW \_\_\_\_\_ **4.636,00**  
400V~3N \_\_\_\_\_ 112 / 0,64  
50/60 Hz



**PCQT-916ET PIANO COTTURA TRIFASE - N. 8 PIASTRE QUADRE (INCLUSA 1 TESTATA CHIUSURA PIANO MOD.TPA-9)**

19031631

**EN** Boiling unit threephase - N. 8 square plates (included 1 Head end filler strip mod.TPA-9) • **DE** Kochplatte dreiphasig - N. 8 quadratischen Platten (inbegriffen 1 Abschluss-Element mod.TPA-9) • **FR** Rechaud électriques - N. 8 plaques carrés (inclus 1 Élément de jonction top mod.TPA-9) • **ES** Sobre de cocción trifásico - N. 8 planchas cuadradas (incluida 1 Chapa de cierre para top mod.TPA-9)  
**cm. 160x 90x 28h**



⚡ 32 kW \_\_\_\_\_ **5.768,00**  
400V~3N \_\_\_\_\_ 150 / 0,96  
50/60 Hz



**PCCT-94ET PIANO COTTURA VETROCERAMICA TRIFASE - N. 2 ZONE - VETRO CM.35X77 (INCLUSA 1 TESTATA CHIUSURA PIANO MOD.TPA-9)**

19030432

**EN** Ceramic glass boiling unit - n. 2 zones - glass cm.35x77 (included 1 Head end filler strip mod.TPA-9) • **DE** Ceran-Kochplatte dreiphasig - 2 zonen - Glas 35x77 cm (inbegriffen 1 Abschluss-Element mod.TPA-9) • **FR** Plan de cuisson à vitroceramique triphasé N. 2 zones - Verre cm.35x77 (inclus 1 Élément de jonction top mod.TPA-9) • **ES** Sobre de cocción trifásico vitrocerámica - 2 zonas - vidrio cm.35x77 (incluida 1 Chapa de cierre para top mod.TPA-9)  
**cm. 40x 90x 28h**



⚡ 6,8 kW \_\_\_\_\_ **1.983,00**  
400V~2N \_\_\_\_\_ 38 / 0,23  
230V~3  
230V~  
50/60 Hz

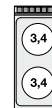

**PCCT-98ET PIANO COTTURA VETROCERAMICA TRIFASE - N. 4 ZONE - VETRO CM.75X77 (INCLUSA 1 TESTATA CHIUSURA PIANO MOD.TPA-9)**

19030832

**EN** Ceramic glass boiling unit - n. 4 zones - glass cm.75x77 (included 1 Head end filler strip mod.TPA-9) • **DE** Ceran-Kochplatte dreiphasig - 4 zonen - Glas 75x77 cm (inbegriffen 1 Abschluss-Element mod.TPA-9) • **FR** Plan de cuisson à vitroceramique triphasé N. 4 zones - Verre cm.75x77 (inclus 1 Élément de jonction top mod.TPA-9) • **ES** Sobre de cocción trifásico vitrocerámica - 4 zonas - vidrio cm.75x77 (incluida 1 Chapa de cierre para top mod.TPA-9)  
**cm. 80x 90x 28h**



⚡ 13,6 kW \_\_\_\_\_ **3.473,00**  
400V~3N \_\_\_\_\_ 70 / 0,44  
230V~3  
50/60 Hz

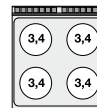

**PCIT-94ET PIANO COTTURA INDUZIONE TRIFASE - N. 2 ZONE - VETRO CM.35X77 (NON POSIZIONARE SU FORNI O CASSETTIERE) (INCLUSA 1 TESTATA CHIUSURA PIANO MOD.TPA-9)**

19030433

**EN** Three-phase induction cooking - 2 zones - glass cm.35x77 (do not place on ovens or drawers) (included 1 Head end filler strip mod.TPA-9) • **DE** Induktions-Kochplatte dreiphasig - 2 zonen - Glas 35x77 cm (nicht Platz auf Öfen oder Schubladen) (inbegriffen 1 Abschluss-Element mod.TPA-9) • **FR** Plan de cuisson à induction triphasé N. 2 zones - Verre cm.35x77 (ne placez pas sur des fours ou des tiroirs) (inclus 1 Élément de jonction top mod.TPA-9) • **ES** Encimera inducción trifásica - 2 zonas - Vidrio cm.35x77 (No coloque en los hornos o en los cajones) (incluida 1 Chapa de cierre para top mod.TPA-9)  
**cm. 40x 90x 28h**



⚡ 10 kW \_\_\_\_\_ **6.803,00**  
400V~3 \_\_\_\_\_ 38 / 0,23  
50/60 Hz

# PIANI COTTURA A INDUZIONE - TOP

MOD. \_\_\_\_\_  
COD. \_\_\_\_\_

DESCRIZIONE/DESCRIPTION/BEZEICHNUNG/DESCRIPTION/DESCRIPCIÓN  
DIMENSIONI/DIMENSIONS/ABMESSUNGEN/DIMENSIONS/DIMENSIONES

POTENZA/POWER/LEISTUNG/PUISSANCE/POTENCIA  
VOLTAGGIO/VOLTAGE/SPANNUNG/VOLTAGE/VOLTAJE

⚡ kW \_\_\_\_\_  
400V~3 \_\_\_\_\_  
50/60 Hz \_\_\_\_\_

PREZZO/PRICE € \_\_\_\_\_  
PREIS/PRIX/PRECIO € \_\_\_\_\_  
KG / M<sup>3</sup> \_\_\_\_\_

**PCIT-94ETD**  
19030438

**PIANO COTTURA INDUZIONE TRIFASE**  
**- N. 2 ZONE - VETRO CM.35X77 (NON**  
**POSIZIONARE SU FORNI O CASSETTIERE)**  
**- COMANDI DIGITALI (INCLUSA 1 TESTATA**  
**CHIUSURA PIANO MOD.TPA-9)**

**EN** Three-phase induction cooking - 2 zones - glass cm.35x77 (do not place on ovens or drawers) - digital controls (included 1 Head end filler strip mod.TPA-9) • **DE** Induktions-Kochplatte dreiphasig - 2 zonen - Glas 35x77 cm (nicht Platz auf Öfen oder Schubladen) - digitale Steuerungen (inbegriffen 1 Abschluss-Element mod.TPA-9) • **FR** Plan de cuisson à induction triphasé N. 2 zones - Verre cm.35x77 (ne placez pas sur des fours ou des tiroirs) - commandes numériques (inclus 1 Élément de jonction top mod.TPA-9) • **ES** Encimera inducción trifásica - 2 zonas - Vidrio cm.35x77 (No coloque en los hornos o en los cajones) - controles digitales (incluida 1 Chapa de cierre para top mod. TPA-9)

**cm. 40x 90x 28h**



⚡ 10 kW \_\_\_\_\_ **7.286,00**  
400V~3 \_\_\_\_\_ 38 / 0,23  
50/60 Hz \_\_\_\_\_

**PCIWT-94ET**  
19030434

**PIANO COTTURA INDUZIONE TRIFASE "WOK"**  
**- N. 1 ZONA - VETRO Ø 30 CM. (NON**  
**POSIZIONARE SU FORNI O CASSETTIERE)**  
**(INCLUSA 1 TESTATA CHIUSURA PIANO MOD.**  
**TPA-9)**

**EN** Three-phase induction cooking "WOK" - 1 zone - glass Ø 30 cm (do not place on ovens or drawers) (included 1 Head end filler strip mod.TPA-9) • **DE** Induktions-Kochplatte "WOK" dreiphasig - 1 zonen - Glas Ø 30 cm (nicht Platz auf Öfen oder Schubladen) (inbegriffen 1 Abschluss-Element mod.TPA-9) • **FR** Plan de cuisson à induction "WOK" triphasé N. 1 zone - Verre cm Ø 30 (ne placez pas sur des fours ou des tiroirs) (inclus 1 Élément de jonction top mod. TPA-9) • **ES** Encimera inducción "WOK" trifásica - 1 zona - Vidrio Ø 30 cm (No coloque en los hornos o en los cajones) (incluida 1 Chapa de cierre para top mod. TPA-9)

**cm. 40x 90x 28h**



⚡ 5 kW \_\_\_\_\_ **4.975,00**  
400V~3 \_\_\_\_\_ 34 / 0,23  
50/60 Hz \_\_\_\_\_

**PCIWT-94ETD**  
19030439

**PIANO COTTURA INDUZIONE TRIFASE "WOK"**  
**- N. 1 ZONA - VETRO Ø 30 CM. (NON**  
**POSIZIONARE SU FORNI O CASSETTIERE)**  
**- COMANDI DIGITALI (INCLUSA 1 TESTATA**  
**CHIUSURA PIANO MOD.TPA-9)**

**EN** Three-phase induction cooking "WOK" - 1 zone - glass Ø 30 cm (do not place on ovens or drawers) - digital controls (included 1 Head end filler strip mod. TPA-9) • **DE** Induktions-Kochplatte "WOK" dreiphasig - 1 zonen - Glas Ø 30 cm (nicht Platz auf Öfen oder Schubladen) - digitale Steuerungen (inbegriffen 1 Abschluss-Element mod.TPA-9) • **FR** Plan de cuisson à induction "WOK" triphasé N. 1 zone - Verre cm Ø 30 (ne placez pas sur des fours ou des tiroirs) - commandes numériques (inclus 1 Élément de jonction top mod.TPA-9) • **ES** Encimera inducción "WOK" trifásica - 1 zona - Vidrio Ø 30 cm (No coloque en los hornos o en los cajones) - controles digitales (incluida 1 Chapa de cierre para top mod.TPA-9)

**cm. 40x 90x 28h**



⚡ 5 kW \_\_\_\_\_ **5.216,00**  
400V~3 \_\_\_\_\_ 34 / 0,23  
50/60 Hz \_\_\_\_\_



Le immagini presentate non sono vincolanti. La ditta si riserva di apportare modifiche senza preavviso. • The pictures are purely representative. The manufacturer reserves the right to modify the technical data and models without previous notice. • Les images

**LO**

présentées ne nous engagent pas. La Société se réserve le droit d'apporter tout modification sans préavis. • Die dargestellten Abbildungen sind nicht verbindlich. Technische Änderungen vorbehalten. • Las imágenes presentadas no son vinculantes. El Fabricante se reserva el derecho de modificar sus productos sin previo aviso.

01/20

**313**



# PIANI COTTURA A INDUZIONE - TOP

MOD. \_\_\_\_\_  
COD. \_\_\_\_\_

DESCRIZIONE/DESCRIPTION/BEZEICHNUNG/DESCRIPTION/DESCRIPCIÓN  
DIMENSIONI/DIMENSIONS/ABMESSUNGEN/DIMENSIONS/DIMENSIONES

POTENZA/POWER/LEISTUNG/PUISSANCE/POTENCIA  
VOLTAGGIO/VOLTAGE/SPANNUNG/VOLTAGE/VOLTAJE

⚡ kW kcal/h  
V~ Hz

PREZZO/PRICE €  
PREIS/PRIX/PRECIO €  
KG / M<sup>3</sup>

**PICIT-98ET**  
19030833

**PIANO COTTURA INDUZIONE TRIFASE - N. 4 ZONE - VETRO CM.75X77 (NON POSIZIONARE SU FORNI O CASSETTIERE) (INCLUSA 1 TESTATA CHIUSURA PIANO MOD. TPA-9)**

**EN** Three-phase induction cooking - 4 zones - glass cm.75x77 (do not place on ovens or drawers) (included 1 Head end filler strip mod.TPA-9) • **DE** Induktions-Kochplatte dreiphasig - 4 zonen - Glas 75x77 cm (nicht Platz auf Öfen oder Schubladen) (inbegriffen 1 Abschluss-Element mod.TPA-9) • **FR** Plan de cuisson à induction triphasé N. 4 zones - Verre cm.75x77 (ne placez pas sur des fours ou des tiroirs) (inclus 1 Élément de jonction top mod.TPA-9) • **ES** Encimera inducción trifásica - 4 zonas - Vidrio cm.75x77 (No coloque en los hornos o en los cajones) (incluida 1 Chapa de cierre para top mod.TPA-9)  
**cm. 80x 90x 28h**

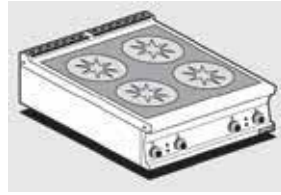

⚡ 20 kW **13.060,00**  
400V~3 76 / 0,44  
50/60 Hz

**PICIT-98ETD**  
19030838

**PIANO COTTURA INDUZIONE TRIFASE - N. 4 ZONE - VETRO CM.75X77 (NON POSIZIONARE SU FORNI O CASSETTIERE) - COMANDI DIGITALI (INCLUSA 1 TESTATA CHIUSURA PIANO MOD.TPA-9)**

**EN** Three-phase induction cooking - 4 zones - glass cm.75x77 (do not place on ovens or drawers) - digital controls (included 1 Head end filler strip mod.TPA-9) • **DE** Induktions-Kochplatte dreiphasig - 4 zonen - Glas 75x77 cm (nicht Platz auf Öfen oder Schubladen) - digitale Steuerungen (inbegriffen 1 Abschluss-Element mod.TPA-9) • **FR** Plan de cuisson à induction triphasé N. 4 zones - Verre cm.75x77 (ne placez pas sur des fours ou des tiroirs) - commandes numériques (inclus 1 Élément de jonction top mod.TPA-9) • **ES** Encimera inducción trifásica - 4 zonas - Vidrio cm.75x77 (No coloque en los hornos o en los cajones) - controles digitales (incluida 1 Chapa de cierre para top mod.TPA-9)  
**cm. 80x 90x 28h**



⚡ 20 kW **14.026,00**  
400V~3 76 / 0,44  
50/60 Hz

**PCT-94G**  
19210450

**PIANO COTTURA GAS 2 FUOCHI (INCLUSA 1 TESTATA CHIUSURA PIANO MOD.TPC-9)**

**EN** Gas heated boiling - 2 burners (included 1 Head end filler strip mod.TPC-9) • **DE** Gas-Kochplatte - 2 Kochstellen (inbegriffen 1 Abschluss-Element mod.TPC-9) • **FR** Rechaud gaz - 2 feux vifs (inclus 1 Élément de jonction top mod.TPC-9) • **ES** Sobres de cocción gas - 2 quemadores (incluida 1 Chapa de cierre para top mod.TPC-9)  
**cm. 40x 90x 28h**



⚡ 11 kW **1.383,00**  
9.460 kcal/h 64 / 0,23



**PCT-98G**  
19210850

**PIANO COTTURA GAS 4 FUOCHI (INCLUSA 1 TESTATA CHIUSURA PIANO MOD.TPC-9)**

**EN** Gas heated boiling unit - 4 burners (included 1 Head end filler strip mod.TPC-9) • **DE** Gas-Kochplatte - 4 Kochstellen (inbegriffen 1 Abschluss-Element mod.TPC-9) • **FR** Rechaud gaz - 4 feux vifs (inclus 1 Élément de jonction top mod.TPC-9) • **ES** Sobres de cocción gas - 4 quemadores (incluida 1 Chapa de cierre para top mod.TPC-9)  
**cm. 80x 90x 28h**



⚡ 28 kW **2.422,00**  
24.080 kcal/h 80 / 0,44

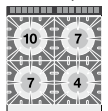

**PCT-912G**  
19211250

**PIANO COTTURA GAS 6 FUOCHI (INCLUSA 1 TESTATA CHIUSURA PIANO MOD.TPC-9)**

**EN** Gas heated boiling unit - 6 burners (included 1 Head end filler strip mod.TPC-9) • **DE** Gas-kochplatte - 6 Kochstellen (inbegriffen 1 Abschluss-Element mod.TPC-9) • **FR** Rechaud gaz - 6 feux vifs (inclus 1 Élément de jonction top mod.TPC-9) • **ES** Sobres de cocción gas - 6 quemadores (incluida 1 Chapa de cierre para top mod.TPC-9)  
**cm. 120x 90x 28h**



⚡ 45 kW **3.412,00**  
38.700 kcal/h 131 / 0,64

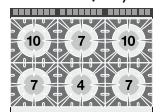

# PIANI COTTURA A GAS - TOP

MOD. \_\_\_\_\_  
COD. \_\_\_\_\_

DESCRIZIONE/DESCRIPTION/BEZEICHNUNG/DESCRIPTION/DESCRIPCIÓN  
DIMENSIONI/DIMENSIONS/ABMESSUNGEN/DIMENSIONS/DIMENSIONES

POTENZA/POWER/LEISTUNG/PUISSANCE/POTENCIA  
VOLTAGGIO/VOLTAGE/SPANNUNG/VOLTAGE/VOLTAJE

⚡ kW  
kcal/h

⚡ kw  
V~  
Hz

PREZZO/PRICE €  
PREIS/PRIX/PRECIO €  
KG / M<sup>3</sup>

**PCT-916G**  
19211650

**PIANO COTTURA GAS 8 FUOCHI (INCLUSA 1 TESTATA CHIUSURA PIANO MOD.TPC-9)**  
**EN** Gas heated boiling unit - 8 burners (included 1 Head end filler strip mod.TPC-9) • **DE** Gas-kochplatte - 8 Kochstellen (inbegriffen 1 Abschluss-Element mod.TPC-9) • **FR** Rechaud gaz - 8 feux vifs (inclus 1 Élément de jonction top mod.TPC-9) • **ES** Sobres de cocción gas - 8 quemadores (incluida 1 Chapa de cierre para top mod.TPC-9)  
**cm. 160x 90x 28h**



⚡ 56 kW  
48.160 kcal/h

**4.437,00**  
168 / 0,96

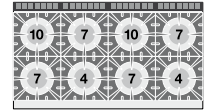

**PAT-98G**  
19210851

**"PAELLERO" GAS (INCLUSA 1 TESTATA CHIUSURA PIANO MOD.TPC-9)**  
**EN** "PAELLERO" Gas (included 1 Head end filler strip mod.TPC-9) • **DE** "PAELLERO" Gas (inbegriffen 1 Abschluss-Element mod.TPC-9) • **FR** "PAELLERO" gaz (inclus 1 Élément de jonction top mod.TPC-9) • **ES** "PAELLERO" gas (incluida 1 Chapa de cierre para top mod.TPC-9)  
**cm. 80x 90x 28h**



⚡ 26,7 kW  
22.962 kcal/h

**3.553,00**  
139 / 0,44

**TPT-94G**  
19290450

**TUTTA PIASTRA PIASTRA CM 39X73 (INCLUSA 1 TESTATA CHIUSURA PIANO MOD.TPC-9)**  
**EN** Solid top - Plate 39x73 cm (included 1 Head end filler strip mod.TPC-9) • **DE** Kochplatte - Platte 39x73 cm (inbegriffen 1 Abschluss-Element mod.TPC-9) • **FR** Toute plaque - Plaque cm 39x73 (inclus 1 Élément de jonction top mod.TPC-9) • **ES** Placa de cocción - Placa cm 39x73 (incluida 1 Chapa de cierre para top mod.TPC-9)  
**cm. 40x 90x 28h**

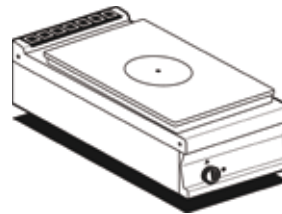

⚡ 7 kW  
6.020 kcal/h

**1.747,00**  
64 / 0,23

**TPT-98G**  
19290850

**TUTTA PIASTRA PIASTRA CM 79X73 (INCLUSA 1 TESTATA CHIUSURA PIANO MOD.TPC-9)**  
**EN** Solid top - Plate 79x73 cm (included 1 Head end filler strip mod.TPC-9) • **DE** Kochplatte - Platte 79x73 cm (inbegriffen 1 Abschluss-Element mod.TPC-9) • **FR** Toute plaque - Plaque cm. 79x73 (inclus 1 Élément de jonction top mod.TPC-9) • **ES** Placa de cocción - Placa cm 79x73 (incluida 1 Chapa de cierre para top mod.TPC-9)  
**cm. 80x 90x 28h**



⚡ 12 kW  
10.320 kcal/h

**2.563,00**  
137 / 0,44

**TPT-98ET**  
19120830

**TUTTA PIASTRA PIASTRA CM. 70X68 - 4 ZONE (INCLUSA 1 TESTATA CHIUSURA PIANO MOD.TPA-9)**  
**EN** Solid top - Plate cm. 70x68 (included 1 Head end filler strip mod.TPA-9) • **DE** Kochplatten - Platte cm. 70x68 (inbegriffen 1 Abschluss-Element mod.TPA-9) • **FR** Toute plaque - Plaque cm. 70x68 (inclus 1 Élément de jonction top mod.TPA-9) • **ES** Placa de cocción - Placa cm. 70x68 (incluida 1 Chapa de cierre para top mod.TPA-9)  
**cm. 80x 90x 28h**



⚡ 13,6 kW  
400V~3N  
50/60 Hz

**3.231,00**  
108 / 0,44

**TPT-98ET**  
19120833

**TUTTOPIANO INDUZIONE TRIFASE - VETRO CM.75X77 (NON POSIZIONARE SU FORNI O CASSETTIERE) (INCLUSA 1 TESTATA CHIUSURA PIANO MOD.TPA-9)**  
**EN** Three-phase induction Solid top - glass cm.75x77 (do not place on ovens or drawers) (included 1 Head end filler strip mod.TPA-9) • **DE** Induktions-Kochplatte dreiphasig - Glas 75x77 cm (nicht Platz auf Öfen oder Schubladen) (inbegriffen 1 Abschluss-Element mod.TPA-9) • **FR** Toute plaque à induction triphasé - Verre cm.75x77 (ne placez pas sur des fours ou des tiroirs) (inclus 1 Élément de jonction top mod.TPA-9) • **ES** Placa de cocción inducción trifásica - Vidrio cm.75x77 (No coloque en los hornos o en los cajones) (incluida 1 Chapa de cierre para top mod.TPA-9)  
**cm. 80x 90x 28h**



⚡ 28 kW  
400V~3  
50/60 Hz

**19.379,00**  
80 / 0,44



Le immagini presentate non sono vincolanti. La ditta si riserva di apportare modifiche senza preavviso. • The pictures are purely representative. The manufacturer reserves the right to modify the technical data and models without previous notice. • Les images

LO

présentées ne nous engagent pas. La Société se réserve le droit d'apporter tout modification sans préavis. • Die dargestellten Abbildungen sind nicht verbindlich. Technische Änderungen vorbehalten. • Las imágenes presentadas no son vinculantes. El Fabricante se reserva el derecho de modificar sus productos sin previo aviso.

01/20

**315**

96

MOD. \_\_\_\_\_  
COD. \_\_\_\_\_

DESCRIZIONE/DESCRIPTION/BEZEICHNUNG/DESCRIPTION/DESCRIPCIÓN  
DIMENSIONI/DIMENSIONS/ABMESSUNGEN/DIMENSIONS/DIMENSIONES

POTENZA/POWER/LEISTUNG/PUISSANCE/POTENCIA  
VOLTAGGIO/VOLTAGE/SPANNUNG/VOLTAGE/VOLTAJE

⚡ kW kcal/h  
400V~  
50/60 Hz

PREZZO/PRICE €  
PREIS/PRIX/PRECIO €  
KG / M<sup>3</sup>

**TPIT-98ETD**  
19120838

**TUTTOPIANO INDUZIONE TRIFASE - VETRO CM.75X77 (NON POSIZIONARE SU FORNI O CASSETTIERE) - COMANDI DIGITALI (INCLUSA 1 TESTATA CHIUSURA PIANO MOD.TPA-9)**  
**EN** Three-phase induction Solid top - glass cm.75x77 (do not place on ovens or drawers) - digital controls (included 1 Head end filler strip mod.TPA-9) • **DE** Induktions-Kochplatte dreiphasig - Glas 75x77 cm (nicht Platz auf Öfen oder Schubladen) - digitale Steuerungen (inbegriffen 1 Abschluss-Element mod.TPA-9) • **FR** Toute plaque à induction triphasé - Verre cm.75x77 (ne placez pas sur des fours ou des tiroirs) - commandes numériques (inclus 1 Élément de jonction top mod.TPA-9) • **ES** Placa de cocción inducción trifásica - Vidrio cm.75x77 (No coloque en los hornos o en los cajones) - controles digitales (incluida 1 Chapa de cierre para top mod.TPA-9)  
**cm. 80x 90x 28h**



⚡ 28 kW **20.344,00**  
400V~3 80 / 0,44  
50/60 Hz

**TP2T-98G**  
19300850

**TUTTA PIASTRA + 2 FUOCHI - PIASTRA CM 39X73 (INCLUSA 1 TESTATA CHIUSURA PIANO MOD.TPC-9)**  
**EN** Solid top + 2 burners - Plate 39x73 cm (included 1 Head end filler strip mod.TPC-9) • **DE** Kochplatte + 2 Gaskochstellen - Platte 39x73 cm (inbegriffen 1 Abschluss-Element mod.TPC-9) • **FR** Toute plaque + 2 brûleurs - Plaque cm 39x73 (inclus 1 Élément de jonction top mod.TPC-9) • **ES** Placa de cocción + 2 fuegos - Placa cm 39x73 (incluida 1 Chapa de cierre para top mod.TPC-9)  
**cm. 80x 90x 28h**



⚡ 24 kW **2.628,00**  
20.640 kcal/h 130 / 0,44

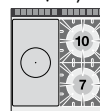

**TP2T-912G**  
19291250

**TUTTA PIASTRA + 2 FUOCHI PIASTRA CM. 79X73 (INCLUSA 1 TESTATA CHIUSURA PIANO MOD.TPC-9)**  
**EN** Solid top + 2 burners - Plate 79x73 cm (included 1 Head end filler strip mod.TPC-9) • **DE** Kochplatte + 2 Gaskochstellen - Platte 79x73 cm (inbegriffen 1 Abschluss-Element mod.TPC-9) • **FR** Toute plaque + 2 brûleurs - Plaque cm. 79x73 (inclus 1 Élément de jonction top mod.TPC-9) • **ES** Placa de cocción + 2 fuegos - Placa cm. 79x73 (incluida 1 Chapa de cierre para top mod.TPC-9)  
**cm. 120x 90x 28h**



⚡ 29 kW **3.811,00**  
24.940 kcal/h 157 / 0,64

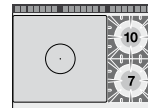

**TP4T-912G**  
19301250

**TUTTA PIASTRA + 4 FUOCHI PIASTRA CM. 39X73 (INCLUSA 1 TESTATA CHIUSURA PIANO MOD.TPC-9)**  
**EN** Solid top + 4 burners - Plate 39x73 cm (included 1 Head end filler strip mod.TPC-9) • **DE** Kochplatte + 4 Gaskochstellen - Platte 39x73 cm (inbegriffen 1 Abschluss-Element mod.TPC-9) • **FR** Toute plaque + 4 brûleurs - Plaque cm. 39x73 (inclus 1 Élément de jonction top mod.TPC-9) • **ES** Placa de cocción + 4 fuegos - Placa cm. 39x73 (incluida 1 Chapa de cierre para top mod.TPC-9)  
**cm. 120x 90x 28h**



⚡ 35 kW **3.594,00**  
30.100 kcal/h 155 / 0,64

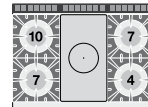

**BMT-94EM**  
19050410

**BAGNOMARIA MONOFASE VASCA PER GN 1/1 + GN 1/3 H15 (INCLUSA 1 TESTATA CHIUSURA PIANO MOD.TPA-9)**  
**EN** Bain marie singlephase - Bowl for GN 1/1 + GN 1/3 h.15 (included 1 Head end filler strip mod.TPA-9) • **DE** Wasserbäder einphasig - Becken GN 1/1 + GN 1/3 h.15 (inbegriffen 1 Abschluss-Element mod.TPA-9) • **FR** Bain marie monophasé - Cuve GN 1/1 + GN 1/3 h.15 (inclus 1 Élément de jonction top mod.TPA-9) • **ES** Baño de maría monofásico - Cuba para GN 1/1 + GN 1/3 15h (incluida 1 Chapa de cierre para top mod.TPA-9)  
**cm. 40x 90x 28h**



⚡ 2,85 KW **1.359,00**  
230V~ 39 / 0,23  
50/60 Hz

# TUTTAPIASTRA A GAS - TOP

MOD. \_\_\_\_\_  
COD. \_\_\_\_\_

DESCRIZIONE/DESCRIPTION/BEZEICHNUNG/DESCRIPTION/DESCRIPCIÓN  
DIMENSIONI/DIMENSIONS/ABMESSUNGEN/DIMENSIONS/DIMENSIONES

POTENZA/POWER/LEISTUNG/PUISSANCE/POTENCIA  
VOLTAGGIO/VOLTAGE/SPANNUNG/VOLTAGE/VOLTAJE

⚡ kW  
kcal/h

PREZZO/PRICE €  
PREIS/PRIX/PRECIO €  
KG / M<sup>3</sup>

**BMT-98ET**  
19050830

**BAGNOMARIA TRIFASE VASCA PER GN 2/1 + 2 X GN 1/3 H.15 (INCLUSA 1 TESTATA CHIUSURA PIANO MOD.TPA-9)**

**EN** Bain marie threephase - Bowl for GN 2/1 + 2 x GN 1/3 h.15 (included 1 Head end filler strip mod.TPA-9) • **DE** Wasserbäder dreiphasig - Becken GN 2/1 + 2 x GN 1/3 h.15 (inbegriffen 1 Abschluss-Element mod.TPA-9) • **FR** Bain marie triphase - Cuve GN 2/1 + 2 x GN 1/3 h.15 (inclus 1 Élément de jonction top mod.TPA-9) • **ES** Baño de maría trifásico - Cuba para GN 2/1 + 2 x GN 1/3 h.15 (incluida 1 Chapa de cierre para top mod.TPA-9)  
**cm. 80x 90x 28h**



⚡ 5,7 kW  
400V~3N  
230V~3  
50/60 Hz

**1.941,00**  
54 / 0,44

**BMT-94G**  
19220450

**BAGNOMARIA GAS VASCA PER GN 1/1 + GN 1/3 H.15 (INCLUSA 1 TESTATA CHIUSURA PIANO MOD.TPA-9)**

**EN** Gas bain-marie - Bowl for GN 1/1 + GN 1/3 h.15 (included 1 Head end filler strip mod.TPA-9) • **DE** Gas Wasserbad - Becken GN 1/1 + GN 1/3 h.15 (inbegriffen 1 Abschluss-Element mod.TPA-9) • **FR** Bain-marie gaz - Cuve pour GN 1/1 + GN 1/3 h.15 (inclus 1 Élément de jonction top mod.TPA-9) • **ES** Baño de maría gas - Cuba para GN 1/1 + GN 1/3 15h (incluida 1 Chapa de cierre para top mod.TPA-9)  
**cm. 40x 90x 28h**



⚡ 3,5 kW  
3.010 kcal/h

**1.615,00**  
48 / 0,23

**BMT-98G**  
19220850

**BAGNOMARIA GAS VASCA PER GN 2/1 + 2 X GN 1/3 H.15 (INCLUSA 1 TESTATA CHIUSURA PIANO MOD.TPA-9)**

**EN** Gas bain-marie - Bowl for GN 2/1 + 2 x GN 1/3 h.15 (included 1 Head end filler strip mod.TPA-9) • **DE** Gas Wasserbad - Becken GN 2/1 + 2 x GN 1/3 h.15 (inbegriffen 1 Abschluss-Element mod.TPA-9) • **FR** Bain-marie gaz - Cuve pour GN 2/1 + 2 x GN 1/3 h.15 (inclus 1 Élément de jonction top mod.TPA-9) • **ES** Baño de maría gas - Cuba para GN 2/1 + 2 x GN 1/3 15h (incluida 1 Chapa de cierre para top mod.TPA-9)  
**cm. 80x 90x 28h**



⚡ 6,5 kW  
5.590 kcal/h

**2.369,00**  
61 / 0,44

**BST-94EM**  
19040410

**CONTENITORE CALDO CON INFRAROSSO MONOFASE VASCA CM. 30,5X51X16,5H CON FALSO FONDO FORATO (INCLUSA 1 TESTATA CHIUSURA PIANO MOD.TPA-9)**

**EN** Fry dump singlephase with infra-red heater. Bowl cm. 30,5x51x16,5h with perforated double bottom (included 1 Head end filler strip mod.TPA-9) • **DE** Frittenwanne Einphasig mit Infrarot-strahler. Becke cm. 30,5x51x16,5h mit gelochtem Bodenrost (inbegriffen 1 Abschluss-Element mod.TPA-9) • **FR** Silo a frites monophasé avec infrarouge. Cuve cm 30,5x51x16,5h avec double-fond perforé. (inclus 1 Élément de jonction top mod.TPA-9) • **ES** Contenedor caliente por infrarrojo monofásico. Cuba cm. 30,5x51x16,5h con falso fondo agujereado (incluida 1 Chapa de cierre para top mod.TPA-9)  
**cm. 40x 90x 28h**



⚡ 1,47 kW  
230V~  
50/60 Hz

**1.393,00**  
48 / 0,26



# CONTENITORE CALDO INFRAROSSO - TOP

MOD. \_\_\_\_\_  
COD. \_\_\_\_\_

DESCRIZIONE/DESCRIPTION/BEZEICHNUNG/DESCRIPTION/DESCRIPCIÓN  
DIMENSIONI/DIMENSIONS/ABMESSUNGEN/DIMENSIONS/DIMENSIONES

POTENZA/POWER/LEISTUNG/PUISSANCE/POTENCIA  
VOLTAGGIO/VOLTAGE/SPANNUNG/VOLTAGE/VOLTAJE

⚡ kW kcal/h  
⚡ kW V~ Hz

PREZZO/PRICE €  
PREIS/PRIX/PRECIO €  
KG / M<sup>3</sup>

**FTLT-94ET**  
19060431

**FRY-TOP ELETTRICO LISCIO, PIASTRA CM.36X68 (INCLUSA 1 TESTATA CHIUSURA PIANO MOD.TPA-9)**

**EN** Electric Fry-top smooth griddle, plate cm.36x68 (included 1 Head end filler strip mod.TPA-9) • **DE** Griddleplatte elektrische glatt, platte cm.36x68 (inbegriffen 1 Abschluss-Element mod.TPA-9) • **FR** Plaque électriques lisse, plaque cm.36x68 (inclus 1 Elément de jonction top mod.TPA-9) • **ES** Fry-top eléctrico liso, plancha cm.36x68 (incluida 1 Chapa de cierre para top mod.TPA-9)  
**cm. 40x 90x 28h**



⚡ 7,5 kW **1.851,00**  
400V~3N 69 / 0,23  
50/60 Hz

**FTLT-94ETS**  
19060434

**FRY-TOP ELETTRICO LISCIO CROMATO SUPERCHROME (MOCA APPROVED), PIASTRA CM.36X68 (INCLUSA 1 TESTATA CHIUSURA PIANO MOD.TPA-9)**

**EN** Electric Fry-top smooth chromed griddle SUPERCHROME (Moca Approved), plate cm.36x68 (included 1 Head end filler strip mod.TPA-9) • **DE** Griddleplatte elektrische glatt hartverchromt SUPERCHROME (Moca Approved), platte cm.36x68 (inbegriffen 1 Abschluss-Element mod.TPA-9) • **FR** Plaque électriques lisse chromée SUPERCHROME (Moca Approved), plaque cm.36x68 (inclus 1 Elément de jonction top mod.TPA-9) • **ES** Fry-top eléctrico liso cromado SUPERCHROME (Moca Approved), plancha cm.36x68 (incluida 1 Chapa de cierre para top mod.TPA-9)  
**cm. 40x 90x 28h**

⚡ 7,5 kW **2.320,00**  
400V~3N 69 / 0,23  
50/60 Hz

**FVRT-94ET**  
19060433

**FRY-TOP ELETTRICO RIGATO, PIASTRA CM.36X68 (INCLUSA 1 TESTATA CHIUSURA PIANO MOD.TPA-9)**

**EN** Electric Fry-top grooved griddle, plate cm.36x68 (included 1 Head end filler strip mod.TPA-9) • **DE** Griddleplatte elektrische gerillt, platte cm.36x68 (inbegriffen 1 Abschluss-Element mod.TPA-9) • **FR** Plaque électriques nervurée, plaque cm.36x68 (inclus 1 Elément de jonction top mod.TPA-9) • **ES** Fry-top eléctrico estriado, plancha cm.36x68 (incluida 1 Chapa de cierre para top mod.TPA-9)  
**cm. 40x 90x 28h**



⚡ 7,5 kW **1.967,00**  
400V~3N 69 / 0,23  
50/60 Hz

**FVRT-94ETS**  
19060436

**FRY-TOP ELETTRICO RIGATO CROMATO SUPERCHROME (MOCA APPROVED), PIASTRA CM.36X68 (INCLUSA 1 TESTATA CHIUSURA PIANO MOD.TPA-9)**

**EN** Electric Fry-top grooved chromed griddle SUPERCHROME (Moca Approved), plate cm.36x68 (included 1 Head end filler strip mod.TPA-9) • **DE** Griddleplatte elektrische gerillt hartverchromt SUPERCHROME (Moca Approved), platte cm.36x68 (inbegriffen 1 Abschluss-Element mod.TPA-9) • **FR** Plaque électriques nervurée chromée SUPERCHROME (Moca Approved), plaque cm.36x68 (inclus 1 Elément de jonction top mod.TPA-9) • **ES** Fry-top eléctrico estriado cromado SUPERCHROME (Moca Approved), plancha cm.36x68 (incluida 1 Chapa de cierre para top mod.TPA-9)  
**cm. 40x 90x 28h**

⚡ 7,5 kW **2.432,00**  
400V~3N 69 / 0,23  
50/60 Hz



# FRY-TOP ELETTRICI - TOP

MOD. \_\_\_\_\_  
COD. \_\_\_\_\_

DESCRIZIONE/DESCRIPTION/BEZEICHNUNG/DESCRIPTION/DESCRIPCIÓN  
DIMENSIONI/DIMENSIONS/ABMESSUNGEN/DIMENSIONS/DIMENSIONES

POTENZA/POWER/LEISTUNG/PUISSANCE/POTENCIA  
VOLTAGGIO/VOLTAGE/SPANNUNG/VOLTAGE/VOLTAJE

⚡ kW kcal/h ⚡ kW V~ Hz PREZZO/PRICE € PREIS/PRIX/PRECIO € KG / M<sup>3</sup>

**FTLT-98ET**  
19060831

**FRY-TOP ELETTRICO LISCIO, PIASTRA CM.76X68 - 2 ZONE DI COTTURA (INCLUSA 1 TESTATA CHIUSURA PIANO MOD.TPA-9)**  
**EN** Electric Fry-top smooth griddle, plate cm.76x68 - 2 cooking areas (included 1 Head end filler strip mod.TPA-9) • **DE** Griddleplatte elektrische glatt, platte cm.76x68 - 2 Heizzonen (inbegriffen 1 Abschluss-Element mod. TPA-9) • **FR** Plaque électriques lisse, plaque cm.76x68 - 2 zones de cuisson (inclus 1 Élément de jonction top mod.TPA-9) • **ES** Fry-top eléctrico liso, plancha cm.76x68 - 2 zonas de cocción (incluida 1 Chapa de cierre para top mod.TPA-9)  
**cm. 80x 90x 28h**



⚡ 15 kW **2.742,00**  
400V~3N 103 / 0,44  
50/60 Hz

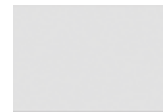

**FTLT-98ETS**  
19060834

**FRY-TOP ELETTRICO LISCIO CROMATO SUPERCHROME (MOCA APPROVED), PIASTRA CM.76X68 - 2 ZONE DI COTTURA (INCLUSA 1 TESTATA CHIUSURA PIANO MOD.TPA-9)**  
**EN** Electric Fry-top smooth chromed griddle SUPERCHROME (Moca Approved), plate cm.76x68 - 2 cooking areas (included 1 Head end filler strip mod.TPA-9) • **DE** Griddleplatte elektrische glatt hartverchromt SUPERCHROME (Moca Approved), platte cm.76x68 - 2 Heizzonen (inbegriffen 1 Abschluss-Element mod.TPA-9) • **FR** Plaque électriques lisse chromée SUPERCHROME (Moca Approved), plaque cm.76x68 - 2 zones de cuisson (inclus 1 Élément de jonction top mod.TPA-9) • **ES** Fry-top eléctrico liso cromado SUPERCHROME (Moca Approved), plancha cm.76x68 - 2 zonas de cocción (incluida 1 Chapa de cierre para top mod. TPA-9)  
**cm. 80x 90x 28h**

⚡ 15 kW **3.366,00**  
400V~3N 103 / 0,44  
50/60 Hz

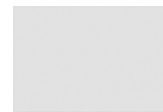

**FTLRT-98ET**  
19060832

**FRY-TOP ELETTRICO 1/2 RIGATO + 1/2 LISCIO, PIASTRA CM.76X68 - 2 ZONE DI COTTURA (INCLUSA 1 TESTATA CHIUSURA PIANO MOD. TPA-9)**  
**EN** Electric Fry-top 1/2 grooved + 1/2 smooth, plate cm.76x68 - 2 cooking areas (included 1 Head end filler strip mod.TPA-9) • **DE** Griddleplatte elektrische 1/2 gerillt + 1/2 glatt, platte cm.76x68 - 2 Heizzonen (inbegriffen 1 Abschluss-Element mod.TPA-9) • **FR** Plaque électriques 1/2 nervurée + 1/2 lisse, plaque cm.76x68 - 2 zones de cuisson (inclus 1 Élément de jonction top mod.TPA-9) • **ES** Fry-top eléctrico 1/2 estriado + 1/2 liso, plancha cm.76x68 - 2 zonas de cocción (incluida 1 Chapa de cierre para top mod. TPA-9)  
**cm. 80x 90x 28h**



⚡ 15 kW **2.879,00**  
400V~3N 103 / 0,44  
50/60 Hz



**FTLRT-98ETS**  
19060835

**FRY-TOP ELETTRICO 1/2 RIGATO + 1/2 LISCIO CROMATO SUPERCHROME (MOCA APPROVED), PIASTRA CM.76X68 - 2 ZONE DI COTTURA (INCLUSA 1 TESTATA CHIUSURA PIANO MOD.TPA-9)**  
**EN** Electric Fry-top 1/2 grooved + 1/2 smooth chromed griddle SUPERCHROME (Moca Approved), plate cm.76x68 - 2 cooking areas (included 1 Head end filler strip mod.TPA-9) • **DE** Griddleplatte elektrische 1/2 gerillt + 1/2 glatt hartverchromt SUPERCHROME (Moca Approved), platte cm.76x68 - 2 Heizzonen (inbegriffen 1 Abschluss-Element mod.TPA-9) • **FR** Plaque électriques 1/2 nervurée + 1/2 lisse chromée SUPERCHROME (Moca Approved), plaque cm.76x68 - 2 zones de cuisson (inclus 1 Élément de jonction top mod.TPA-9) • **ES** Fry-top eléctrico 1/2 estriado + 1/2 liso cromado SUPERCHROME (Moca Approved), plancha cm.76x68 - 2 zonas de cocción (incluida 1 Chapa de cierre para top mod.TPA-9)  
**cm. 80x 90x 28h**

⚡ 15 kW **3.502,00**  
400V~3N 103 / 0,44  
50/60 Hz



Le immagini presentate non sono vincolanti. La ditta si riserva di apportare modifiche senza preavviso. • The pictures are purely representative. The manufacturer reserves the right to modify the technical data and models without previous notice. • Les images

LO

présentées ne nous engagent pas. La Société se réserve le droit d'apporter tout modification sans préavis. • Die dargestellten Abbildungen sind nicht verbindlich. Technische Änderungen vorbehalten. • Las imágenes presentadas no son vinculantes. El Fabricante se reserva el derecho de modificar sus productos sin previo aviso.

01/20

319

90

# FRY-TOP ELETTRICI - TOP

MOD. \_\_\_\_\_  
COD. \_\_\_\_\_

DESCRIZIONE/DESCRIPTION/BEZEICHNUNG/DESCRIPTION/DESCRIPCIÓN  
DIMENSIONI/DIMENSIONS/ABMESSUNGEN/DIMENSIONS/DIMENSIONES

POTENZA/POWER/LEISTUNG/PUISSANCE/POTENCIA  
VOLTAGGIO/VOLTAGE/SPANNUNG/VOLTAGE/VOLTAJE

⚡ kW \_\_\_\_\_  
400V~3N  
50/60 Hz

PREZZO/PRICE €  
PREIS/PRIX/PRECIO €  
KG / M<sup>3</sup>

**FTRT-98ET**  
19060833

**FRY-TOP ELETTRICO RIGATO, PIASTRA CM.76X68 - 2 ZONE DI COTTURA (INCLUSA 1 TESTATA CHIUSURA PIANO MOD.TPA-9)**

**EN** Electric Fry-top grooved griddle, plate cm.76x68 - 2 cooking areas (included 1 Head end filler strip mod.TPA-9) • **DE** Griddleplatte elektrische gerillt, platte cm.76x68 - 2 Heizzonen (inbegriffen 1 Abschluss-Element mod. TPA-9) • **FR** Plaque électriques nervurée, plaque cm.76x68 - 2 zones de cuisson (inclus 1 Élément de jonction top mod.TPA-9) • **ES** Fry-top eléctrico estriado, plancha cm.76x68 - 2 zonas de cocción (incluida 1 Chapa de cierre para top mod.TPA-9)  
**cm. 80x 90x 28h**



⚡ 15 kW \_\_\_\_\_ **3.019,00**  
400V~3N \_\_\_\_\_ 103 / 0,44  
50/60 Hz



**FTRT-98ETS**  
19060836

**FRY-TOP ELETTRICO RIGATO CROMATO SUPERCHROME (MOCA APPROVED), PIASTRA CM.76X68 - 2 ZONE DI COTTURA (INCLUSA 1 TESTATA CHIUSURA PIANO MOD.TPA-9)**

**EN** Electric Fry-top grooved chromed griddle SUPERCHROME (Moca Approved), plate cm.76x68 - 2 cooking areas (included 1 Head end filler strip mod.TPA-9) • **DE** Griddleplatte elektrische gerillt hartverchromt SUPERCHROME (Moca Approved), platte cm.76x68 - 2 Heizzonen (inbegriffen 1 Abschluss-Element mod. TPA-9) • **FR** Plaque électriques nervurée chromée SUPERCHROME (Moca Approved), plaque cm.76x68 - 2 zones de cuisson (inclus 1 Élément de jonction top mod.TPA-9) • **ES** Fry-top eléctrico estriado cromado SUPERCHROME (Moca Approved), plancha cm.76x68 - 2 zonas de cocción (incluida 1 Chapa de cierre para top mod.TPA-9)  
**cm. 80x 90x 28h**

⚡ 15 kW \_\_\_\_\_ **3.637,00**  
400V~3N \_\_\_\_\_ 103 / 0,44  
50/60 Hz



**FTLT-912ET**  
1906123B

**FRY-TOP ELETTRICO LISCIO, PIASTRA CM.110,5X65 - 3 ZONE DI COTTURA (INCLUSA 1 TESTATA CHIUSURA PIANO MOD. TPA-9)**

**EN** Electric Fry-top smooth griddle, plate cm.110,5x65 - 3 cooking areas (included 1 Head end filler strip mod.TPA-9) • **DE** Griddleplatte elektrische glatt, platte cm.110,5x65 - 3 Heizzonen (inbegriffen 1 Abschluss-Element mod.TPA-9) • **FR** Plaque électriques lisse, plaque cm.110,5x65 - 3 zones de cuisson (inclus 1 Élément de jonction top mod.TPA-9) • **ES** Fry-top eléctrico liso, plancha cm.110,5x65 - 3 zonas de cocción (incluida 1 Chapa de cierre para top mod. TPA-9)  
**cm. 120x 90x 28h**



⚡ 22,5 kW \_\_\_\_\_ **4.465,00**  
400V~3N \_\_\_\_\_ 161 / 0,64  
50/60 Hz

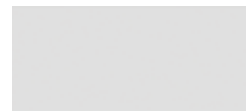

**FTLT-912ETS**  
1906123E

**FRY-TOP ELETTRICO LISCIO CROMATO SUPERCHROME (MOCA APPROVED), PIASTRA CM.110,5X65 - 3 ZONE DI COTTURA (INCLUSA 1 TESTATA CHIUSURA PIANO MOD. TPA-9)**

**EN** Electric Fry-top smooth chromed griddle SUPERCHROME (Moca Approved), plate cm.110,5x65 - 3 cooking areas (included 1 Head end filler strip mod.TPA-9) • **DE** Griddleplatte elektrische glatt hartverchromt SUPERCHROME (Moca Approved), platte cm.110,5x65 - 3 Heizzonen (inbegriffen 1 Abschluss-Element mod.TPA-9) • **FR** Plaque électriques lisse chromée SUPERCHROME (Moca Approved), plaque cm.110,5x65 - 3 zones de cuisson (inclus 1 Élément de jonction top mod.TPA-9) • **ES** Fry-top eléctrico liso cromado SUPERCHROME (Moca Approved), plancha cm.110,5x65 - 3 zonas de cocción (incluida 1 Chapa de cierre para top mod.TPA-9)  
**cm. 120x 90x 28h**

⚡ 22,5 kW \_\_\_\_\_ **5.164,00**  
400V~3N \_\_\_\_\_ 161 / 0,64  
50/60 Hz



# FRY-TOP ELETTRICI - TOP

MOD. \_\_\_\_\_  
COD. \_\_\_\_\_

DESCRIZIONE/DESCRIPTION/BEZEICHNUNG/DESCRIPTION/DESCRIPCIÓN  
DIMENSIONI/DIMENSIONS/ABMESSUNGEN/DIMENSIONS/DIMENSIONES

POTENZA/POWER/LEISTUNG/PUISSANCE/POTENCIA  
VOLTAGGIO/VOLTAGE/SPANNUNG/VOLTAGE/VOLTAJE

⚡ kW kcal/h  
⚡ kW V~ Hz

PREZZO/PRICE €  
PREIS/PRIX/PRECIO €  
KG / M<sup>3</sup>

**FTLRT-912ET FRY-TOP ELETTRICO 1/3 RIGATO + 2/3 LISCIO, PIASTRA CM.110,5X65 - 3 ZONE DI COTTURA (INCLUSA 1 TESTATA CHIUSURA PIANO MOD. TPA-9)**

1906123C

**EN** Electric Fry-top 1/3 grooved + 2/3 smooth, plate cm.110,5x65 - 3 cooking areas (included 1 Head end filler strip mod.TPA-9) • **DE** Griddleplatte elektrische 1/3 gerillt + 2/3 glatt, platte cm.110,5x65 - 3 Heizzonen (inbegriffen 1 Abschluss-Element mod. TPA-9) • **FR** Plaque électriques 1/3 nervurée + 2/3 lisse, plaque cm.110,5x65 - 3 zones de cuisson (inclus 1 Élément de jonction top mod.TPA-9) • **ES** Fry-top eléctrico 1/3 estriado + 2/3 liso, plancha cm.110,5x65 - 3 zonas de cocción (incluida 1 Chapa de cierre para top mod.TPA-9)

**cm. 120x 90x 28h**



⚡ 22,5 kW 4.761,00  
400V~3N 161 / 0,64  
50/60 Hz



**FTLRT-912ETS FRY-TOP ELETTRICO 1/3 RIGATO + 2/3 LISCIO CROMATO SUPERCHROME (MOCA APPROVED), PIASTRA CM.110,5X65 - 3 ZONE DI COTTURA (INCLUSA 1 TESTATA CHIUSURA PIANO MOD.TPA-9)**

1906123F

**EN** Electric Fry-top 1/3 grooved + 2/3 smooth chromed griddle SUPERCHROME (Moca Approved), plate cm.110,5x65 - 3 cooking areas (included 1 Head end filler strip mod.TPA-9) • **DE** Griddleplatte elektrische 1/3 gerillt + 2/3 glatt hartverchromt SUPERCHROME (Moca Approved), platte cm.110,5x65 - 3 Heizzonen (inbegriffen 1 Abschluss-Element mod. TPA-9) • **FR** Plaque électriques 1/3 nervurée + 2/3 lisse chromée SUPERCHROME (Moca Approved), plaque cm.110,5x65 - 3 zones de cuisson (inclus 1 Élément de jonction top mod.TPA-9) • **ES** Fry-top eléctrico 1/3 estriado + 2/3 liso cromado SUPERCHROME (Moca Approved), plancha cm.110,5x65 - 3 zonas de cocción (incluida 1 Chapa de cierre para top mod.TPA-9)

**cm. 120x 90x 28h**

⚡ 22,5 kW 5.461,00  
400V~3N 161 / 0,64  
50/60 Hz



**FTLT-94G FRY-TOP GAS LISCIO, PIASTRA CM.36X68 (INCLUSA 1 TESTATA CHIUSURA PIANO MOD. TPA-9)**

19230451

**EN** Gas Fry-top smooth griddle, plate cm.36x68 (included 1 Head end filler strip mod.TPA-9) • **DE** Gas-griddleplatte glatt, platte cm.36x68 (inbegriffen 1 Abschluss-Element mod.TPA-9) • **FR** Plaque gaz lisse, plaque cm.36x68 (inclus 1 Élément de jonction top mod.TPA-9) • **ES** Fry-top gas liso, plancha cm.36x68 (incluida 1 Chapa de cierre para top mod.TPA-9)

**cm. 40x 90x 28h**



⚡ 9 kW 1.931,00  
7.7440 kcal/h 71 / 0,23



**FTLT-94GS FRY-TOP GAS LISCIO CROMATO SUPERCHROME (MOCA APPROVED), PIASTRA CM.36X68 (INCLUSA 1 TESTATA CHIUSURA PIANO MOD.TPA-9)**

19230454

**EN** Gas Fry-top smooth chromed griddle SUPERCHROME (Moca Approved), plate cm.36x68 (included 1 Head end filler strip mod.TPA-9) • **DE** Gas-griddleplatte glatt hartverchromt SUPERCHROME (Moca Approved), platte cm.36x68 (inbegriffen 1 Abschluss-Element mod.TPA-9) • **FR** Plaque gaz lisse chromée SUPERCHROME (Moca Approved), plaque cm.36x68 (inclus 1 Élément de jonction top mod.TPA-9) • **ES** Fry-top gas liso cromado SUPERCHROME (Moca Approved), plancha cm.36x68 (incluida 1 Chapa de cierre para top mod.TPA-9)

**cm. 40x 90x 28h**

⚡ 9 kW 2.313,00  
7.7440 kcal/h 71 / 0,23



Le immagini presentate non sono vincolanti. La ditta si riserva di apportare modifiche senza preavviso. • The pictures are purely representative. The manufacturer reserves the right to modify the technical data and models without previous notice. • Les images

LO

présentées ne nous engagent pas. La Société se réserve le droit d'apporter tout modification sans préavis. • Die dargestellten Abbildungen sind nicht verbindlich. Technische Änderungen vorbehalten. • Las imágenes presentadas no son vinculantes. El Fabricante se reserva el derecho de modificar sus productos sin previo aviso.

01/20

321

90

# FRY-TOP A GAS - TOP

MOD. \_\_\_\_\_  
COD. \_\_\_\_\_

DESCRIZIONE/DESCRIPTION/BEZEICHNUNG/DESCRIPTION/DESCRIPCIÓN  
DIMENSIONI/DIMENSIONS/ABMESSUNGEN/DIMENSIONS/DIMENSIONES

POTENZA/POWER/LEISTUNG/PUISSANCE/POTENCIA  
VOLTAGGIO/VOLTAGE/SPANNUNG/VOLTAGE/VOLTAJE

9 kW  
7.7440 kcal/h

PREZZO/PRICE €  
PREIS/PRIX/PRECIO €  
KG / M<sup>3</sup>

**FTRT-94G**  
19230453

**FRY-TOP GAS RIGATO, PIASTRA CM.36X68 (INCLUSA 1 TESTATA CHIUSURA PIANO MOD. TPA-9)**

**EN** Gas Fry-top grooved griddle, plate cm.36x68 (included 1 Head end filler strip mod.TPA-9) • **DE** Gas-griddleplatte gerillt, platte cm.36x68 (inbegriffen 1 Abschluss-Element mod.TPA-9) • **FR** Plaque gaz nervurée, plaque cm.36x68 (inclus 1 Élément de jonction top mod.TPA-9) • **ES** Fry-top gas estriado, plancha cm.36x68 (incluida 1 Chapa de cierre para top mod. TPA-9)

**cm. 40x 90x 28h**



9 kW  
7.7440 kcal/h

**2.024,00**  
71 / 0,23

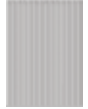

**FTRT-94GS**  
19230456

**FRY-TOP GAS RIGATO CROMATO SUPERCHROME (MOCA APPROVED), PIASTRA CM.36X68 (INCLUSA 1 TESTATA CHIUSURA PIANO MOD.TPA-9)**

**EN** Gas Fry-top grooved chromed griddle SUPERCHROME (Moca Approved), plate cm.36x68 (included 1 Head end filler strip mod.TPA-9) • **DE** Gas-griddleplatte gerillt hartverchromt SUPERCHROME (Moca Approved), platte cm.36x68 (inbegriffen 1 Abschluss-Element mod.TPA-9) • **FR** Plaque gaz nervurée chromée SUPERCHROME (Moca Approved), plaque cm.36x68 (inclus 1 Élément de jonction top mod.TPA-9) • **ES** Fry-top gas estriado cromado SUPERCHROME (Moca Approved), plancha cm.36x68 (incluida 1 Chapa de cierre para top mod.TPA-9)

**cm. 40x 90x 28h**

9 kW  
7.7440 kcal/h

**2.421,00**  
71 / 0,23

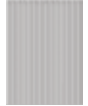

**FTLT-98G**  
19230851

**FRY-TOP GAS LISCIO, PIASTRA CM.76X68 - 2 ZONE DI COTTURA (INCLUSA 1 TESTATA CHIUSURA PIANO MOD.TPA-9)**

**EN** Gas Fry-top smooth griddle, plate cm.76x68 - 2 cooking areas (included 1 Head end filler strip mod. TPA-9) • **DE** Gas-griddleplatte glatt, platte cm.76x68 - 2 Heizzonen (inbegriffen 1 Abschluss-Element mod. TPA-9) • **FR** Plaque gaz lisse, plaque cm.76x68 - 2 zones de cuisson (inclus 1 Élément de jonction top mod. TPA-9) • **ES** Fry-top gas liso, plancha cm.76x68 - 2 zonas de cocción (incluida 1 Chapa de cierre para top mod.TPA-9)

**cm. 80x 90x 28h**



18 kW  
15.480 kcal/h

**2.962,00**  
108 / 0,44

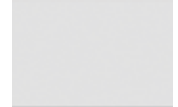

**FTLT-98GS**  
19230854

**FRY-TOP GAS LISCIO CROMATO SUPERCHROME (MOCA APPROVED), PIASTRA CM.76X68 - 2 ZONE DI COTTURA (INCLUSA 1 TESTATA CHIUSURA PIANO MOD.TPA-9)**

**EN** Gas Fry-top smooth chromed griddle SUPERCHROME (Moca Approved), plate cm.76x68 - 2 cooking areas (included 1 Head end filler strip mod. TPA-9) • **DE** Gas-griddleplatte glatt hartverchromt SUPERCHROME (Moca Approved), platte cm.76x68 - 2 Heizzonen (inbegriffen 1 Abschluss-Element mod. TPA-9) • **FR** Plaque gaz lisse chromée SUPERCHROME (Moca Approved), plaque cm.76x68 - 2 zones de cuisson (inclus 1 Élément de jonction top mod.TPA-9) • **ES** Fry-top gas liso cromado SUPERCHROME (Moca Approved), plancha cm.76x68 - 2 zonas de cocción (incluida 1 Chapa de cierre para top mod.TPA-9)

**cm. 80x 90x 28h**

18 kW  
15.480 kcal/h

**3.683,00**  
108 / 0,44

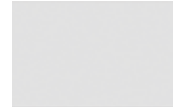

# FRY-TOP A GAS - TOP

MOD. \_\_\_\_\_  
COD. \_\_\_\_\_

DESCRIZIONE/DESCRIPTION/BEZEICHNUNG/DESCRIPTION/DESCRIPCIÓN  
DIMENSIONI/DIMENSIONS/ABMESSUNGEN/DIMENSIONS/DIMENSIONES

POTENZA/POWER/LEISTUNG/PUISSANCE/POTENCIA  
VOLTAGGIO/VOLTAGE/SPANNUNG/VOLTAGE/VOLTAJE

18 kW  
15.480 kcal/h

PREZZO/PRICE €  
PREIS/PRIX/PRECIO €  
KG / M<sup>3</sup>

**FTLRT-98G**  
19230852

**FRY-TOP GAS 1/2 RIGATO + 1/2 LISCIO, PIASTRA CM.76X68 - 2 ZONE DI COTTURA (INCLUSA 1 TESTATA CHIUSURA PIANO MOD. TPA-9)**

**EN** Gas Fry-top 1/2 grooved + 1/2 smooth, plate cm.76x68 - 2 cooking areas (included 1 Head end filler strip mod.TPA-9) • **DE** Gas-griddleplatte 1/2 gerillt + 1/2 glatt, platte cm.76x68 - 2 Heizzonen (inbegriffen 1 Abschluss-Element mod.TPA-9) • **FR** Plaque gaz 1/2 nervurée + 1/2 lisse, plaque cm.76x68 - 2 zones de cuisson (inclus 1 Élément de jonction top mod.TPA-9) • **ES** Fry-top gas 1/2 estriado + 1/2 liso, plancha cm.76x68 - 2 zonas de cocción (incluida 1 Chapa de cierre para top mod.TPA-9)  
**cm. 80x 90x 28h**



18 kW  
15.480 kcal/h

**3.099,00**  
108 / 0,44



**FTLRT-98GS**  
19230855

**FRY-TOP GAS 1/2 RIGATO + 1/2 LISCIO CROMATO SUPERCHROME (MOCA APPROVED), PIASTRA CM.76X68 - 2 ZONE DI COTTURA (INCLUSA 1 TESTATA CHIUSURA PIANO MOD.TPA-9)**

**EN** Gas Fry-top 1/2 grooved + 1/2 smooth chromed griddle SUPERCHROME (Moca Approved), plate cm.76x68 - 2 cooking areas (included 1 Head end filler strip mod.TPA-9) • **DE** Gas-griddleplatte 1/2 gerillt + 1/2 glatt hartverchromt SUPERCHROME (Moca Approved), platte cm.76x68 - 2 Heizzonen (inbegriffen 1 Abschluss-Element mod.TPA-9) • **FR** Plaque gaz 1/2 nervurée + 1/2 lisse chromée SUPERCHROME (Moca Approved), plaque cm.76x68 - 2 zones de cuisson (inclus 1 Élément de jonction top mod.TPA-9) • **ES** Fry-top gas 1/2 estriado + 1/2 liso cromado SUPERCHROME (Moca Approved), plancha cm.76x68 - 2 zonas de cocción (incluida 1 Chapa de cierre para top mod.TPA-9)  
**cm. 80x 90x 28h**

18 kW  
15.480 kcal/h

**3.824,00**  
108 / 0,44



**FTRT-98G**  
19230853

**FRY-TOP GAS RIGATO, PIASTRA CM.76X68 - 2 ZONE DI COTTURA (INCLUSA 1 TESTATA CHIUSURA PIANO MOD.TPA-9)**

**EN** Gas Fry-top grooved griddle, plate cm.76x68 - 2 cooking areas (included 1 Head end filler strip mod.TPA-9) • **DE** Gas-griddleplatte gerillt, platte cm.76x68 - 2 Heizzonen (inbegriffen 1 Abschluss-Element mod.TPA-9) • **FR** Plaque gaz nervurée, plaque cm.76x68 - 2 zones de cuisson (inclus 1 Élément de jonction top mod.TPA-9) • **ES** Fry-top gas estriado, plancha cm.76x68 - 2 zonas de cocción (incluida 1 Chapa de cierre para top mod.TPA-9)  
**cm. 80x 90x 28h**



18 kW  
15.480 kcal/h

**3.235,00**  
108 / 0,44



**FTRT-98GS**  
19230856

**FRY-TOP GAS RIGATO CROMATO SUPERCHROME (MOCA APPROVED), PIASTRA CM.76X68 - 2 ZONE DI COTTURA (INCLUSA 1 TESTATA CHIUSURA PIANO MOD.TPA-9)**

**EN** Gas Fry-top grooved chromed griddle SUPERCHROME (Moca Approved), plate cm.76x68 - 2 cooking areas (included 1 Head end filler strip mod.TPA-9) • **DE** Gas-griddleplatte gerillt hartverchromt SUPERCHROME (Moca Approved), platte cm.76x68 - 2 Heizzonen (inbegriffen 1 Abschluss-Element mod.TPA-9) • **FR** Plaque gaz nervurée chromée SUPERCHROME (Moca Approved), plaque cm.76x68 - 2 zones de cuisson (inclus 1 Élément de jonction top mod.TPA-9) • **ES** Fry-top gas estriado cromado SUPERCHROME (Moca Approved), plancha cm.76x68 - 2 zonas de cocción (incluida 1 Chapa de cierre para top mod.TPA-9)  
**cm. 80x 90x 28h**

18 kW  
15.480 kcal/h

**3.969,00**  
108 / 0,44



Le immagini presentate non sono vincolanti. La ditta si riserva di apportare modifiche senza preavviso. • The pictures are purely representative. The manufacturer reserves the right to modify the technical data and models without previous notice. • Les images

LO

présentées ne nous engagent pas. La Société se réserve le droit d'apporter tout modification sans préavis. • Die dargestellten Abbildungen sind nicht verbindlich. Technische Änderungen vorbehalten. • Las imágenes presentadas no son vinculantes. El Fabricante se reserva el derecho de modificar sus productos sin previo aviso.

01/20

323

90



# FRY-TOP A GAS - TOP

MOD. \_\_\_\_\_  
COD. \_\_\_\_\_

DESCRIZIONE/DESCRIPTION/BEZEICHNUNG/DESCRIPTION/DESCRIPCIÓN  
DIMENSIONI/DIMENSIONS/ABMESSUNGEN/DIMENSIONS/DIMENSIONES

POTENZA/POWER/LEISTUNG/PUISSANCE/POTENCIA  
VOLTAGGIO/VOLTAGE/SPANNUNG/VOLTAGE/VOLTAJE

⚡ kW  
kcal/h

⚡ kw  
V~  
Hz

PREZZO/PRICE €  
PREIS/PRIX/PRECIO €  
KG / M<sup>3</sup>

**FTLT-912G**  
1923125B

**FRY-TOP GAS LISCIO, PIASTRA CM.110,5X65 - 3 ZONE DI COTTURA (INCLUSA 1 TESTATA CHIUSURA PIANO MOD.TPA-9)**

**EN** Gas Fry-top smooth griddle, plate cm.110,5x65 - 3 cooking areas (included 1 Head end filler strip mod.TPA-9) • **DE** Gas-griddleplatte glatt, platte cm.110,5x65 - 3 Heizzonen (inbegriffen 1 Abschluss-Element mod.TPA-9) • **FR** Plaque gaz lisse, plaque cm.110,5x65 - 3 zones de cuisson (inclus 1 Élément de jonction top mod.TPA-9) • **ES** Fry-top gas liso, plancha cm.110,5x65 - 3 zonas de cocción (incluida 1 Chapa de cierre para top mod.TPA-9)  
**cm. 120x 90x 28h**



⚡ 27 kW  
23.220 kcal/h

**4.820,00**  
173 / 0,64

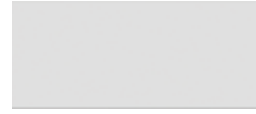

**FTLT-912GS**  
1923125E

**FRY-TOP GAS LISCIO CROMATO SUPERCHROME (MOCA APPROVED), PIASTRA CM.110,5X65 - 3 ZONE DI COTTURA (INCLUSA 1 TESTATA CHIUSURA PIANO MOD.TPA-9)**

**EN** Gas Fry-top smooth chromed griddle SUPERCHROME (Moca Approved), plate cm.110,5x65 - 3 cooking areas (included 1 Head end filler strip mod.TPA-9) • **DE** Gas-griddleplatte glatt hartverchromt SUPERCHROME (Moca Approved), platte cm.110,5x65 - 3 Heizzonen (inbegriffen 1 Abschluss-Element mod.TPA-9) • **FR** Plaque gaz lisse chromée SUPERCHROME (Moca Approved), plaque cm.110,5x65 - 3 zones de cuisson (inclus 1 Élément de jonction top mod.TPA-9) • **ES** Fry-top gas liso cromado SUPERCHROME (Moca Approved), plancha cm.110,5x65 - 3 zonas de cocción (incluida 1 Chapa de cierre para top mod.TPA-9)  
**cm. 120x 90x 28h**

⚡ 27 kW  
23.220 kcal/h

**5.519,00**  
173 / 0,64

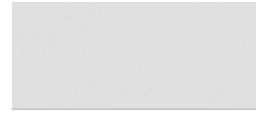

**FTLRT-912G**  
1923125C

**FRY-TOP GAS 1/3 RIGATO + 2/3 LISCIO, PIASTRA CM.110,5X65 - 3 ZONE DI COTTURA (INCLUSA 1 TESTATA CHIUSURA PIANO MOD.TPA-9)**

**EN** Gas Fry-top 1/3 grooved + 2/3 smooth, plate cm.110,5x65 - 3 cooking areas (included 1 Head end filler strip mod.TPA-9) • **DE** Gas-griddleplatte 1/3 gerillt + 2/3 glatt, platte cm.110,5x65 - 3 Heizzonen (inbegriffen 1 Abschluss-Element mod.TPA-9) • **FR** Plaque gaz 1/3 nervurée + 2/3 lisse, plaque cm.110,5x65 - 3 zones de cuisson (inclus 1 Élément de jonction top mod.TPA-9) • **ES** Fry-top gas 1/3 estriado + 2/3 liso, plancha cm.110,5x65 - 3 zonas de cocción (incluida 1 Chapa de cierre para top mod.TPA-9)  
**cm. 120x 90x 28h**



⚡ 27 kW  
23.220 kcal/h

**5.117,00**  
173 / 0,64



**FTLRT-912GS**  
1923125F

**FRY-TOP GAS 1/3 RIGATO + 2/3 LISCIO CROMATO SUPERCHROME (MOCA APPROVED), PIASTRA CM.110,5X65 - 3 ZONE DI COTTURA (INCLUSA 1 TESTATA CHIUSURA PIANO MOD.TPA-9)**

**EN** Gas Fry-top 1/3 grooved + 2/3 smooth chromed SUPERCHROME (Moca Approved), plate cm.110,5x65 - 3 cooking areas (included 1 Head end filler strip mod.TPA-9) • **DE** Gas-griddleplatte 1/3 gerillt + 2/3 glatt hartverchromt SUPERCHROME (Moca Approved), platte cm.110,5x65 - 3 Heizzonen (inbegriffen 1 Abschluss-Element mod.TPA-9) • **FR** Plaque gaz 1/3 nervurée + 2/3 lisse chromée AW770:AW833approved), plaque cm.110,5x65 - 3 zones de cuisson (inclus 1 Élément de jonction top mod.TPA-9) • **ES** Fry-top gas 1/3 estriado + 2/3 liso cromado SUPERCHROME (Moca Approved), plancha cm.110,5x65 - 3 zonas de cocción (incluida 1 Chapa de cierre para top mod.TPA-9)  
**cm. 120x 90x 28h**

⚡ 27 kW  
23.220 kcal/h

**5.816,00**  
173 / 0,64



MOD. \_\_\_\_\_  
COD. \_\_\_\_\_

DESCRIZIONE/DESCRIPTION/BEZEICHNUNG/DESCRIPTION/DESCRIPCIÓN  
DIMENSIONI/DIMENSIONS/ABMESSUNGEN/DIMENSIONS/DIMENSIONES

POTENZA/POWER/LEISTUNG/PUISSANCE/POTENCIA  
VOLTAGGIO/VOLTAGE/SPANNUNG/VOLTAGE/VOLTAJE

⚡ kcal/h  
kw  
V~  
Hz

PREZZO/PRICE €  
PREIS/PRIX/PRECIO €  
KG / M<sup>3</sup>

**CWKT-94ET**  
19080431

**GRIGLIA CONTACT - COTTURA DIRETTA SU RESISTENZA IN ACCIAIO INOX CM. 27X63 RIBALTABILE (INCLUSA 1 TESTATA CHIUSURA PIANO MOD.TPA-9)**

**EN** CONTACT Grill threephase - rotatable stainless steel grill cm. 27x63 (included 1 Head end filler strip mod.TPA-9) • **DE** Wurstbrater dreiphasig KONTAKT - Drehbaren Heizelement aus Edelstahl cm. 27x63 (inbegriffen 1 Abschluss-Element mod.TPA-9) • **FR** Grillade triphase CONTACT - Grille inox rotatif cm 27x63 (inclus 1 Elément de jonction top mod.TPA-9) • **ES** Parrilla trifásico CONTACT - Parrilla giratoria de acero inox cm 27x63 (incluida 1 Chapa de cierre para top mod.TPA-9)  
**cm. 40x 90x 28h**



⚡ 5,415 kW **2.685,00**  
400V~3N 55 / 0,23  
50/60 Hz

**CWKT-98ET**  
19080831

**GRIGLIA CONTACT - COTTURA DIRETTA SU RESISTENZA IN ACCIAIO INOX CM. 55X63 RIBALTABILE - 2 ZONE COTTURA (INCLUSA 1 TESTATA CHIUSURA PIANO MOD.TPA-9)**

**EN** CONTACT Grill threephase - rotatable stainless steel grill cm. 55x63 - 2 cooking areas (included 1 Head end filler strip mod.TPA-9) • **DE** Wurstbrater dreiphasig KONTAKT - Drehbaren Heizelement aus Edelstahl cm. 55x63 - 2 Heizzonen (inbegriffen 1 Abschluss-Element mod.TPA-9) • **FR** Grillade triphase CONTACT - Grille inox rotatif cm 55x63 - 2 zones de cuisson (inclus 1 Elément de jonction top mod.TPA-9) • **ES** Parrilla trifásico CONTACT - Parrilla giratoria de acero inox cm 55x63 - 2 zonas de cocción (incluida 1 Chapa de cierre para top mod.TPA-9)  
**cm. 80x 90x 28h**



⚡ 10,83 kW **3.741,00**  
400V~3N 85 / 0,44  
50/60 Hz

**CWT-94ET**  
19080430

**GRIGLIA TRIFASE GRIGLIA IN ACCIAIO INOX CM. 38X66 REGOLABILE (INCLUSA 1 TESTATA CHIUSURA PIANO MOD.TPA-9)**

**EN** Grill threephase - Stainless steel grill cm. 38x66 (included 1 Head end filler strip mod.TPA-9) • **DE** Wurstbrater dreiphasig - Einstellbarer Rost aus Nirosa cm. 38x66 (inbegriffen 1 Abschluss-Element mod.TPA-9) • **FR** Grillade triphase - Grille inox cm 38x66 (inclus 1 Elément de jonction top mod.TPA-9) • **ES** Parrilla trifásico - Parrilla de acero inox regulable cm 38x66 (incluida 1 Chapa de cierre para top mod.TPA-9)  
**cm. 40x 90x 28h**



⚡ 7,8 kW **2.023,00**  
400V~3N 57 / 0,26  
50/60 Hz

**CWT-98ET**  
19080830

**GRIGLIA TRIFASE N. 2 GRIGLIE IN ACCIAIO INOX CM. 38X66 REGOLABILI 2 ZONE DI COTTURA (INCLUSA 1 TESTATA CHIUSURA PIANO MOD.TPA-9)**

**EN** Grill threephase - N. 2 Stainless steel grill cm. 38x66. 2 cooking areas (included 1 Head end filler strip mod.TPA-9) • **DE** Wurstbrater dreiphasig - N. 2 einstellbare Roste aus Nirosa cm. 38x66 - 2 Heizzonen (inbegriffen 1 Abschluss-Element mod.TPA-9) • **FR** Grillade triphase - N. 2 grilles réglables en acier inox cm. 38x66 - 2 zones de cuisson (inclus 1 Elément de jonction top mod.TPA-9) • **ES** Parrilla trifásico - N. 2 Parrillas de acero inox regulable cm 38x66 - 2 zonas de cocción (incluida 1 Chapa de cierre para top mod.TPA-9)  
**cm. 80x 90x 28h**



⚡ 15,6 kW **3.078,00**  
400V~3N 87 / 0,51  
50/60 Hz

MOD. \_\_\_\_\_  
COD. \_\_\_\_\_

DESCRIZIONE/DESCRIPTION/BEZEICHNUNG/DESCRIPTION/DESCRIPCIÓN  
DIMENSIONI/DIMENSIONS/ABMESSUNGEN/DIMENSIONS/DIMENSIONES

POTENZA/POWER/LEISTUNG/PUISSANCE/POTENCIA  
VOLTAGGIO/VOLTAGE/SPANNUNG/VOLTAGE/VOLTAJE

⚡ kW  
kcal/h

PREZZO/PRICE €  
PREIS/PRIX/PRECIO €  
KG / M<sup>3</sup>

**CWT-94G**  
19250450

**GRIGLIA GAS-PIETRALAVICA GRIGLIA IN ACCIAIO INOX CM. 38X66 REGOLABILE (INCLUSA 1 TESTATA CHIUSURA PIANO MOD. TPA-9)**

**EN** Charcoal grill gas - Stainless steel grill cm. 38x66 (included 1 Head end filler strip mod.TPA-9) • **DE** Gas-Lavasteingrill - Einstellbarer Rost aus Nirosta cm. 38x66 (inbegriffen 1 Abschluss-Element mod.TPA-9) • **FR** Grille à gaz en pierre de lave - Grille inox cm 38x66 (inclus 1 Élément de jonction top mod.TPA-9) • **ES** Parrilla a gas piedra lávica - Parrilla de acero inox regulable cm 38x66 (incluida 1 Chapa de cierre para top mod.TPA-9)  
**cm. 40x 90x 28h**



⚡ 12 kW  
10.320 kcal/h **2.077,00**  
56 / 0,26

**CWT-98G**  
19250850

**GRIGLIA GAS-PIETRALAVICA N. 2 GRIGLIE IN ACCIAIO INOX CM. 38X66 REGOLABILI 2 ZONE DI COTTURA (INCLUSA 1 TESTATA CHIUSURA PIANO MOD.TPA-9)**

**EN** Charcoal grill gas - N. 2 Stainless steel grill cm. 38x66 2 cooking areas (included 1 Head end filler strip mod.TPA-9) • **DE** Gas-Lavasteingrill - N. 2 einstellbare Roste aus Nirosta cm. 38x66 - 2 Heizzonen (inbegriffen 1 Abschluss-Element mod.TPA-9) • **FR** Grille a gaz en pierre de lave - N. 2 grilles réglables en acier inox cm. 38x66 - 2 zones de cuisson (inclus 1 Élément de jonction top mod.TPA-9) • **ES** Parrilla a gas piedra lávica - N. 2 Parrillas de acero inox regulable cm 38x66 - 2 zonas de cocción (incluida 1 Chapa de cierre para top mod. TPA-9)  
**cm. 80x 90x 28h**



⚡ 24 kW  
20.640 kcal/h **3.227,00**  
97 / 0,51

**F2/8T-94ET**  
19090432

**FRIGGITRICE TRIFASE LT. 8+8 2 VASCHE CM. 14,8X35,5X22,5H - 2 CESTI CM. 12X29X11,5H - FILTRO E COPERCHIO VASCA. PRODUZIONE PATATE: 12 KG/H (INCLUSA 1 TESTATA CHIUSURA PIANO MOD.TPA-9)**

**EN** Fryer threephase 8+8 lts - 2 Bowls cm. 14,8x35,5x22,5h - 2 baskets cm. 12x29x11,5h. Sieve and lid for pan. Production: 12 kg/h (included 1 Head end filler strip mod.TPA-9) • **DE** Friteuse dreiphasig lt. 8+8 - 2 Becken cm. 14,8x35,5x22,5h - 2 Korb cm. 12x29x11,5h. Einlegesieb und Deckel für Becken. Pommes frites: 12 kg/h (inbegriffen 1 Abschluss-Element mod.TPA-9) • **FR** Friteuse triphase lt. 8+8 - 2 Cuve cm. 14,8x35,5x22,5h - 2 Panier cm. 12x29x11,5h. Filtre, couvercle pour cuve. Production de pommes frites: 12 kg/h (inclus 1 Élément de jonction top mod. TPA-9) • **ES** Freidoras trifásico 8+8 lt. - 2Cuba cm. 14,8x35,5x22,5h- 2 cesta cm. 12x29x11,5h. Filtro y tapa para cuba. Prod. patatas: 12 Kg/h (incluida 1 Chapa de cierre para top mod.TPA-9)  
**cm. 40x 90x 28h**



⚡ 12 kW  
400V~3N  
230V~3  
50/60 Hz **3.007,00**  
58 / 0,23

**F13T-94ET**  
19090430

**FRIGGITRICE TRIFASE LT. 13 VASCA CM. 30,5X34X22,5H - 1 CESTO CM. 28X29X10H FILTRO E COPERCHIO VASCA - PRODUZIONE PATATE: 10 KG/H (INCLUSA 1 TESTATA CHIUSURA PIANO MOD.TPA-9)**

**EN** Fryer threephase 13 lts - Bowl cm. 30,5x34x22,5h 1 basket cm. 28x29x10h - Sieve and lid for pan Production: 10 kg/h (included 1 Head end filler strip mod.TPA-9) • **DE** Friteuse dreiphasig lt. 13 - Becken cm. 30,5x34x22,5h - 1 Korb cm. 28x29x10h - Einlegesieb und Deckel für Becken - Pommes frites: 10 kg/h (inbegriffen 1 Abschluss-Element mod.TPA-9) • **FR** Friteuse triphase lt. 13 - Cuve cm. 30,5x34x22,5h - 1 Panier cm. 28x29x10h - Filtre, couvercle pour cuve Production de pommes frites: 10 kg/h (inclus 1 Élément de jonction top mod.TPA-9) • **ES** Freidoras trifásico 13 lt. - Cuba cm. 30,5x34x22,5h - 1 cesta cm. 28x29x10h - Filtro y tapa para cuba. Prod. patatas: 10 Kg/h (incluida 1 Chapa de cierre para top mod.TPA-9)  
**cm. 40x 90x 28h**



⚡ 11,95 kW  
400V~3N  
50/60 Hz **2.309,00**  
55 / 0,23

# FRIGGITRICI ELETTRICHE - TOP

MOD. \_\_\_\_\_  
COD. \_\_\_\_\_

DESCRIZIONE/DESCRIPTION/BEZEICHNUNG/DESCRIPTION/DESCRIPCIÓN  
DIMENSIONI/DIMENSIONS/ABMESSUNGEN/DIMENSIONS/DIMENSIONES

POTENZA/POWER/LEISTUNG/PUISSANCE/POTENCIA  
VOLTAGGIO/VOLTAGE/SPANNUNG/VOLTAGE/VOLTAJE

⚡ kW  
kcal/h

PREZZO/PRICE €  
PREIS/PRIX/PRECIO €  
KG / M<sup>3</sup>

## F2/13T-98ET FRIGGITRICE TRIFASE LT. 13+13 2 VASCHE CM.

19090830

**30,5X34X22,5H - 2 CESTI CM. 28X29X10H  
2 FILTRI E COPERCHI VASCHE - PRODUZIONE  
PATATE: 20 KG/H (INCLUSA 1 TESTATA  
CHIUSURA PIANO MOD.TPA-9)**

**EN** Fryer threephase 13+13 lts - 2 pans cm. 30,5x34x22,5h 2 baskets cm. 28x29x10h - 2 sieves and lids for pan Production: 20 kg/h (included 1 Head end filler strip mod.TPA-9) • **DE** Friteuse dreiphasig lt. 13+13 - 2 Becken cm. 30,5x34x22,5h 2 Körbe cm. 28x29x10h - Einlegesieb und Deckel für Becken - Pommes frites: 20 kg/h (inbegriffen 1 Abschluss-Element mod.TPA-9) • **FR** Friteuse triphase lt. 13+13 - 2 cuves cm. 30,5x34x22,5h 2 paniers cm. 28x29x10h - 2 filtres, couvercles pour cuve Production de pommes frites: 20 kg/h (inclus 1 Élément de jonction top mod.TPA-9) • **ES** Freidoras trifásico 13+13 lt. - 2 cubas cm. 30,5x34x22,5h - 2 cestas cm. 28x29x10h - 2 filtros y tapas para cubas Prod. patatas: 20 Kg/h (incluida 1 Chapa de cierre para top mod.TPA-9)  
**cm. 80x 90x 28h**



⚡ 23,9 kW  
400V-3N  
50/60 Hz

**3.355,00**  
75 / 0,44

## F2/8T-94G FRIGGITRICE GAS LT. 8+8 - 2 VASCHE CM.

19260452

**15X35X23H 2 CESTI CM. 12X30X9,5H.  
FILTRO E COPERCHIO VASCA. PROD. PATATE:  
12 KG/H (INCLUSA 1 TESTATA CHIUSURA  
PIANO MOD.TPA-9)**

**EN** Gas Fryer 8+8 lts - 2 pans cm. 15x35x23h 2 baskets cm. 12x30x9,5h. Sieve and lid for pan. Production: 12 kg/h (included 1 Head end filler strip mod.TPA-9) • **DE** Gas-Friteuse lt. 8+8 - 2 Becken cm. 15x35x23h 2 Körbe cm. 12x30x9,5h. Einlegesieb und Deckel für Becken. Pommes frites: 12 kg/h (inbegriffen 1 Abschluss-Element mod.TPA-9) • **FR** Friteuse à gaz lt. 8+8 - 2 cuves cm. 15x35x23h 2 paniers cm. 12x30x9,5h. Filtre, couvercle pour cuve. Production de pommes frites: 12 kg/h (inclus 1 Élément de jonction top mod.TPA-9) • **ES** Freidoras a gas 8+8 lt. - 2 cubas cm. 15x35x23h 2 cestas cm. 12x30x9,5h. Filtro y tapa para cuba. Prod. patatas: 12 Kg/h (incluida 1 Chapa de cierre para top mod.TPA-9)  
**cm. 40x 90x 28h**



⚡ 9 kW  
7.740 kcal/h

**3.525,00**  
58 / 0,23

## F13T-94G FRIGGITRICE GAS LT. 13 - VASCA CM.

19260450

**31,5X34,5X22,5H 1 CESTO CM. 28X29X10H  
- FILTRO E COPERCHIO VASCA. PROD. PATATE:  
10 KG/H (INCLUSA 1 TESTATA CHIUSURA  
PIANO MOD.TPA-9)**

**EN** Gas Fryer 13 lts - Bowl cm. 31,5x34,5x22,5h - 1 basket cm. 28x29x10h - Sieve and lid for pan Production: 10 kg/h (included 1 Head end filler strip mod.TPA-9) • **DE** Gas-Friteuse lt. 13 - Becken cm. 31,5x34,5x22,5h - 1 Korb cm. 28x29x10h - Einlegesieb und Deckel für Becken - Pommes frites: 10 kg/h (inbegriffen 1 Abschluss-Element mod.TPA-9) • **FR** Friteuse à gaz lt. 13 - Cuve cm. 31,5x34,5x22,5h - 1 Panier cm. 28x29x10h - Filtre, couvercle pour cuve Production de pommes frites: 10 kg/h (inclus 1 Élément de jonction top mod.TPA-9) • **ES** Freidoras a gas 13 lt. - Cuba cm. 31,5x34,5x22,5h - 1 cesta cm. 28x29x10h - Filtro y tapa para cuba Prod. patatas: 10 Kg/h (incluida 1 Chapa de cierre para top mod.TPA-9)  
**cm. 40x 90x 28h**



⚡ 12 kW  
10.320 kcal/h

**2.576,00**  
60 / 0,23



Le immagini presentate non sono vincolanti. La ditta si riserva di apportare modifiche senza preavviso. • The pictures are purely representative. The manufacturer reserves the right to modify the technical data and models without previous notice. • Les images

LO

présentées ne nous engagent pas. La Société se réserve le droit d'apporter tout modification sans préavis. • Die dargestellten Abbildungen sind nicht verbindlich. Technische Änderungen vorbehalten. • Las imágenes presentadas no son vinculantes. El Fabricante se reserva el derecho de modificar sus productos sin previo aviso.

01/20

327

90



# FRIGGITRICI A GAS - TOP

MOD. \_\_\_\_\_  
COD. \_\_\_\_\_

DESCRIZIONE/DESCRIPTION/BEZEICHNUNG/DESCRIPTION/DESCRIPCIÓN  
DIMENSIONI/DIMENSIONS/ABMESSUNGEN/DIMENSIONS/DIMENSIONES

POTENZA/POWER/LEISTUNG/PUISSANCE/POTENCIA  
VOLTAGGIO/VOLTAGE/SPANNUNG/VOLTAGE/VOLTAJE

⚡ kW  
kcal/h

⚡ kw  
V~  
Hz

PREZZO/PRICE €  
PREIS/PRIX/PRECIO €  
KG / M<sup>3</sup>

**F2/13T-98G FRIGGITRICE GAS LT. 13+13 2 VASCHE CM. 31,5X34,5X22,5H - 2 CESTI CM. 28X29X10H 2 FILTRI E COPERCHI VASCHE - PROD. PATATE: 20 KG/H (INCLUSA 1 TESTATA CHIUSURA PIANO MOD.TPA-9)**

19260850

**EN** Gas Fryer 13+13 lts - 2 pans cm. 31,5x34,5x22,5h 2 baskets cm. 28x29x10h - 2 sieves and lids for pan Production: 20 kg/h (included 1 Head end filler strip mod.TPA-9) • **DE** Gas-Friteuse lt. 13+13 - 2 Becken cm. 31,5x34,5x22,5h 2 Körbe cm. 28x29x10h - Einlegesieb und Deckel für Becken - Pommes frites: 20 kg/h (inbegriffen 1 Abschluss-Element mod.TPA-9) • **FR** Friteuse à gaz lt. 13+13 - 2 cuves cm. 31,5x34,5x22,5h 2 paniers cm. 28x29x10h - 2 filtres, couvercles pour cuve Production de pommes frites: 20 kg/h (inclus 1 Élément de jonction top mod.TPA-9) • **ES** Freidoras a gas 13+13 lt. - 2 cubas cm. 31,5x34,5x22,5h 2 cestas cm. 28x29x10h - 2 filtros y tapas para cubas. Prod. patatas: 20 Kg/h (incluida 1 Chapa de cierre para top mod.TPA-9)  
**cm. 80x 90x 28h**



⚡ 24 kW  
20.640 kcal/h

**4.103,00**  
81 / 0,44

**MFV-98ET BASE CON FORNO ELETTRICO VENTILATO CM. 55X36X34H, TEMP: 50÷300°C, CON 1 GRIGLIA CM.53X32,5 GN1/1 (NON SOVRAPPORRE ELEMENTI AD INDUZIONE)**

09490830

**EN** Stand with electric fan oven cm. 55x36x34h, temp: 50÷300°C, with 1 grid cm.53x32,5 GN1/1 (no induction top) • **DE** unterbau mit Elektro-Heißluftofen cm. 55x36x34h, temp: 50÷300°C, mit 1 Rost cm.53x32,5 GN1/1 (nicht Induktions) • **FR** placard avec Four à chaleur tournante électrique cm. 55x36x34h, temp: 50÷300°C, avec 1 grille cm.53x32,5 GN1/1 (il faut pas de induction) • **ES** mueble con Horno eléctrico ventilado cm. 55x36x34h, temp: 50÷300°C, con 1 parilla cm.53x32,5 GN1/1 (no inducción)  
**cm. 80x 83x 57h**



⚡ 5,32 kW  
400V~3N  
230V~3  
50/60 Hz

**3.256,00**  
80 / 0,62

**CMF-98 COPERCHIO PER MFV-98E**

09490800

**EN** Lid for MFV-98E • **DE** Berichterstattung für MFV-98E • **FR** Couvercle pour MFV-98E • **ES** cubertura para MFV-98E  
**cm. 80x 82,5x 2,8h**

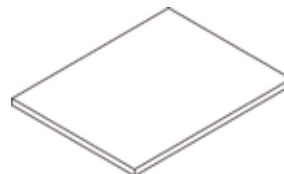

**222,00**  
6 / 0,04

**MPI-94 BASE CON PORTA PER INDUZIONE**

09410403

**EN** Stand with door for induction top • **DE** Unterbau für Induktions mit Tür • **FR** Placard pour induction avec porte • **ES** Mueble base para inducción con puerta  
**cm. 40x 81x 57h**



**673,00**  
22 / 0,26

**MPI-98 cm. 80x 81x 57h**

09410803



**778,00**  
29 / 0,48



MOD. \_\_\_\_\_  
COD. \_\_\_\_\_

DESCRIZIONE/DESCRIPTION/BEZEICHNUNG/DESCRIPTION/DESCRIPCIÓN  
DIMENSIONI/DIMENSIONS/ABMESSUNGEN/DIMENSIONS/DIMENSIONES

POTENZA/POWER/LEISTUNG/PUISSANCE/POTENCIA  
VOLTAGGIO/VOLTAGE/SPANNUNG/VOLTAGE/VOLTAJE

⚡ kW kcal/h  
⚡ kw V~ Hz

PREZZO/PRICE €  
PREIS/PRIX/PRECIO €  
KG / M<sup>3</sup>

**M-92** **BASE NEUTRA**  
09410200 **EN** Stand • **DE** Unterbau • **FR** Placard • **ES** Mueble base  
cm. **20x 78,5x 57h**



**433,00**  
14 / 0,15

**M-93** **BASE NEUTRA A GIORNO**  
09410300 **EN** Open Stand • **DE** Offener Unterbau • **FR** Placard ouvert • **ES** Mueble base abierto  
cm. **30x 78,5x 57h**



**420,00**  
16 / 0,21

**M-94** cm. **40x 78,5x 57h**  
09410400



**462,00**  
19 / 0,26

**M-96** cm. **60x 78,5x 57h**  
09410600



**527,00**  
23 / 0,37

**M-98** cm. **80x 78,5x 57h**  
09410800



**566,00**  
26 / 0,48

**M-912** cm. **120x 78,5x 57h**  
09411200



**756,00**  
38 / 0,70

**M-916** cm. **160x 78,5x 57h**  
09411600



**1.004,00**  
57 / 0,91

**PM-63/73/93-DX PORTA 300 DESTRA**  
08430302 **EN** Right door 300 • **DE** Rechte tür 300 • **FR** Porte droite 300 • **ES** Puerta derecha 300  
cm. **29,5x 2,5x 47,5h**



**157,00**  
3 / 0,01

**PM-64/74/94-DX PORTA 400 DESTRA**  
08430402 **EN** Right door 400 • **DE** Rechte tür 400 • **FR** Porte droite 400 • **ES** Puerta derecha 400  
cm. **39,5x 2,5x 47,5h**



**163,00**  
3.5 / 0,02

MOD. \_\_\_\_\_  
COD. \_\_\_\_\_

DESCRIZIONE/DESCRIPTION/BEZEICHNUNG/DESCRIPTION/DESCRIPCIÓN  
DIMENSIONI/DIMENSIONS/ABMESSUNGEN/DIMENSIONS/DIMENSIONES

POTENZA/POWER/LEISTUNG/PUISSANCE/POTENCIA  
VOLTAGGIO/VOLTAGE/SPANNUNG/VOLTAGE/VOLTAJE

⚡ kW kcal/h  
⚡ kw V~ Hz

PREZZO/PRICE €  
PREIS/PRIX/PRECIO €  
KG / M<sup>3</sup>

**PM-63/73/93-SX PORTA 300 SINISTRA**  
08430303 **EN** Left door 300 • **DE** Linke für 300 • **FR** Porte gauche 300 • **ES** Puerta izquierda 300  
**cm. 29,5x 2,5x 47,5h**



**157,00**  
3 / 0,01

**PM-64/74/94-SX PORTA 400 SINISTRA**  
08430403 **EN** Left door 400 • **DE** Linke für 400 • **FR** Porte gauche 400 • **ES** Puerta izquierda 400  
**cm. 39,5x 2,5x 47,5h**

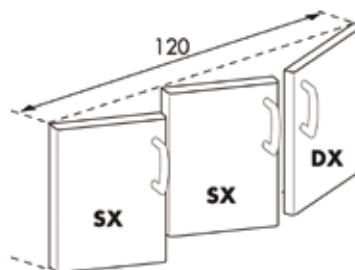

**163,00**  
3.5 / 0,02

**C-73/93 CASSETTIERA 300 N. 2 CASSETTI CON 2 BACINELLE INOX, GUIDE TELESCOPICHE. SOLO SU PL**  
08440320 **EN** Drawer set 300 N. 2 drawers with 2 inox containers, telescopic guides. Only for PL • **DE** Schubladen 300 - N. 2 Schubladen mit 2 Chromnickelstahlbehältern, Telescopeinführungen. Nur für PL • **FR** Tiroirs pour meuble de 300 N. 2 tiroirs avec 2 bacs inox, guides télescopiques. Seulement pour PL • **ES** Cajonera 300 - N. 2 cajones con 2 contenedores de acero inox, guías telescópicas. Solo para PL  
**cm. 29,5x 59x 47,5h**



**611,00**  
16 / 0,19

**C-74/94 CASSETTIERA 400 - N. 2 CASSETTI CON 2 BACINELLE GN 1/1 15H IN PLASTICA, GUIDE TELESCOPICHE.**  
08440420 **EN** Drawer set 400 - N. 2 drawers with 2 GN 1/1 15h plastic containers, telescopic guides. • **DE** Schubladen - N. 2 Schubladen mit 2 GN 1/1 15h Kunststoffbehältern, Telescopeinführungen. • **FR** Tiroirs pour meuble de 400 - N. 2 tiroirs avec 2 bacs en plastique GN 1/1 15h, guides télescopiques. • **ES** Cajonera 400 - N. 2 cajones con 2 contenedores GN 1/1 15h de plástico, guías telescópicas.  
**cm. 39,5x 59x 47,5h**



**627,00**  
18 / 0,19

**C-76/96 CASSETTIERA 600 N. 2 CASSETTI CON 2 BACINELLE INOX, GUIDE TELESCOPICHE.**  
08440620 **EN** Drawer set 600 N. 2 drawers with 2 inox containers, telescopic guides. • **DE** Schubladen 600 - N. 2 Schubladen mit 2 Chromnickelstahlbehältern, Telescopeinführungen. • **FR** Tiroirs pour meuble de 600 N. 2 tiroirs avec 2 bacs inox, guides télescopiques. • **ES** Cajonera 600 - N. 2 cajones con 2 contenedores de acero inox, guías telescópicas.  
**cm. 59,5x 59x 47,5h**



**867,00**  
22 / 0,28

MOD. \_\_\_\_\_  
COD. \_\_\_\_\_

DESCRIZIONE/DESCRIPTION/BEZEICHNUNG/DESCRIPTION/DESCRIPCIÓN  
DIMENSIONI/DIMENSIONS/ABMESSUNGEN/DIMENSIONS/DIMENSIONES

POTENZA/POWER/LEISTUNG/PUISSANCE/POTENCIA  
VOLTAGGIO/VOLTAGE/SPANNUNG/VOLTAGE/VOLTAJE

⚡ kW kcal/h  
⚡ kw V~ Hz

PREZZO/PRICE €  
PREIS/PRIX/PRECIO €  
KG / M<sup>3</sup>

**C-78/98**  
08440820

**CASSETTIERA 800 - N. 2 CASSETTI CON 4 BACINELLE GN 1/1 15H IN PLASTICA, GUIDE TELESCOPICHE.**

**EN** Drawer set 800 - N. 2 drawers with 4 GN 1/1 15h plastic containers, telescopic guides. • **DE** Schubladen 800 - N. 2 Schubladen mit 4 GN 1/1 15h Kunststoffbehältern, Telescopeinführungen. • **FR** Tiroirs pour meuble de 800 - N. 2 tiroirs avec 4 bacs en plastique GN 1/1 15h, guides télescopiques. • **ES** Cajonera 800 - N. 2 cajones con 4 contenedores GN 1/1 15h de plástico, guías telescópicas.

**cm. 79,5x 59x 47,5h**



**883,00**  
26 / 0,37

**D-90**  
09470001

**DIVISORIO BASE NEUTRA**

**EN** Spacer for stand • **DE** Trennwand für offener unterbau • **FR** Separation pour placard ouvert • **ES** Divisorio para mueble base

**cm. 5x 78x 38h**

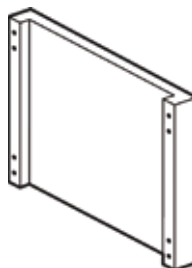

**159,00**  
2.5 / 0,03

**PT-74/94**  
08460002

**PORTATEGLIE VANO 400 (GN-1/1) VANO 600 (GN-2/1) 4 RIPIANI INT. 7 CM.**

**EN** Frame for plates 400 (GN-1/1) 600 (GN-2/1) - N. 4 shelves, wheel-base 7 cm. • **DE** Auflangeschienen für bleche 400 (GN-1/1) 600 (GN-2/1) - N. 4 Etagen, Abstand 7 cm. • **FR** Kit porte-plaques 400 (GN-1/1) 600 (GN-2/1) - N. 4 étagères; 7 cm. • **ES** Portacazuelas 400 (GN-1/1) 600 (GN-2/1) - N. 4 estantes, int. 7 cm.

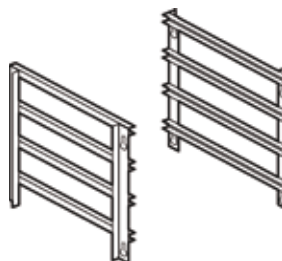

**340,00**  
2.5 / 0,01

**PT-78/98**  
08460012

**PORTATEGLIE VANO 800 (GN-2/1) 4 RIPIANI INT. 7 CM.**

**EN** Frame for plates 800 (GN-2/1) 4 Etagen, Abstand 7 cm. • **DE** Auflangeschienen für bleche 800 (GN-2/1) N. 4 Etagen, Abstand 7 cm. • **FR** Kit porte-plaques 800 (GN-2/1) - N. 4 étagères; 7 cm. • **ES** Portacazuelas 800 (GN-2/1) - N. 4 estantes, int. 7 cm.

**453,00**  
4 / 0,01

**531048800 CESTO 1/2 PER F13T-G/E**

**EN** Basket 1/2 for F13T-G/E • **DE** Korb 1/2 zur Friteuse F13T-G/E • **FR** Panier 1/2 pour F13T-G/E • **ES** Cesta 1/2 para F13T-G/E

**cm. 13,5x 29x 9h**



**72,00**  
0.8 / 0,03





## MONOBLOCCO



## MONOBLOCCO 5.0



LED optional





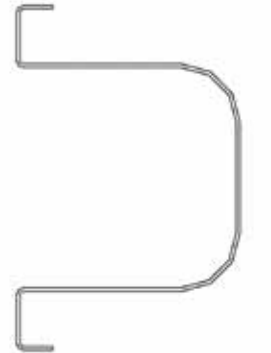
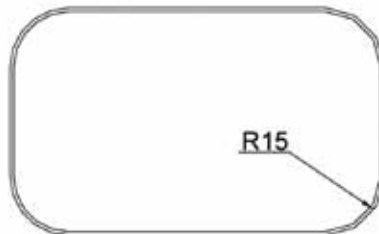
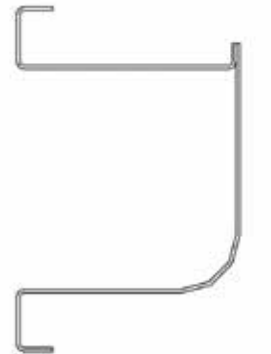
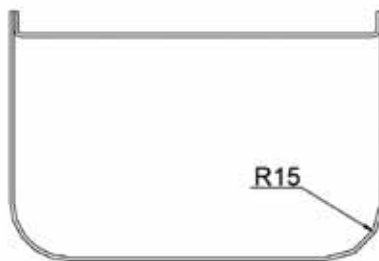
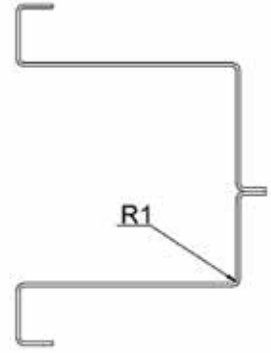
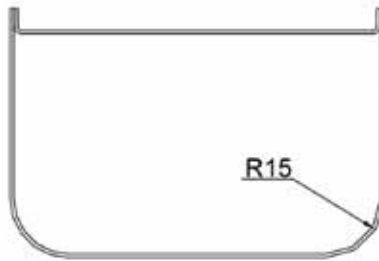
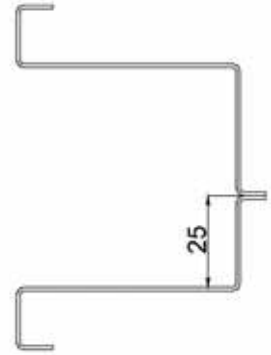
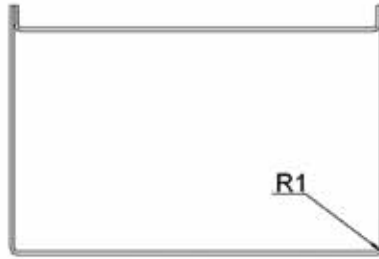

MOD. \_\_\_\_\_  
COD. \_\_\_\_\_

DESCRIZIONE/DESCRIPTION/BEZEICHNUNG/DESCRIPTION/DESCRIPCIÓN  
DIMENSIONI/DIMENSIONS/ABMESSUNGEN/DIMENSIONS/DIMENSIONES

POTENZA/POWER/LEISTUNG/PUISSANCE/POTENCIA  
VOLTAGGIO/VOLTAGE/SPANNUNG/VOLTAGE/VOLTAJE

⚡ kW  
kcal/h

⚡ kw  
V~  
Hz

PREZZO/PRICE €  
PREIS/PRIX/PRECIO €  
KG / M<sup>3</sup>

**MONOBLOCCO IL MONOBLOCCO È COMPOSTO DA STRUTTURA INTERNA, VANI IGIENICI E NON, PANNELLO COMANDI, PIANO ECC... TUTTO È INTERAMENTE REALIZZATO IN ACCIAIO INOX 18/10 FINEMENTE SATINATO, CON PARTICOLARI CROMATI, IL PIANO VIENE INFINE SPAZZOLATO FINO AD OTTENERE UN EFFETTO FINALE ANTIGRAFFIO.**

**EN** The MONOBLOCCO is made up internal frame, hygienic and not hygienic compartments, control panel, top etc. ... everything is made entirely of stainless steel 18/10 with fine satin finish, with chromed details, the top is brushed to obtain a scratchproof effect.

• **DE** Das MONOBLOCCO besteht aus einer internen Struktur, Hygiene oder normale Unterschränke, Bedienungsblende, Oberfläche kratzfest...komplett aus CNS 18/10 mit feinem Schliff, ergänzt mit verchromten Teilen. • **FR** Le MONOBLOCCO se compose de structure interne, avec vannes hygiéniques ou pas, panneau de commandes, plan, etc... tout est fait entièrement en acier inoxydable 18/10 satiné avec des touches de chrome. Le plan est ensuite brossé pour obtenir un effet anti-rayures. • **ES** El MONOBLOCCO se compone por una estructura interna, armarios normales ó higiénicos, panel de control, sobre de trabajo, etc... todo realizado completamente en acero inoxidable 18/10 con acabado satinado fino con detalles cromados, el plano de trabajo suficientemente satinado hasta obtener un efecto a prueba de arañazos.



## MONOBLOCCO ' α

**? A @ BLOC5A 5.0. IL PIANO È UN PEZZO UNICO CON FIANCHI CHE ARRIVANO A TERRA E SONO PORTANTI, TUTTO IN ACCIAIO INOX AISI 304 CRNI 18/10 CON SATINATURA ANTIGRAFFIO E SPESSORE DA 3 MM, RINFORZATO CON TRAVERSE AVVITATE. STRUTTURA E TELAIO INTERAMENTE PORTANTI. GLI ELEMENTI DROP-IN POSSONO ESSERE INSTALLATI INCASSATI E SILICONATI O ESSERE SALDATI INTERAMENTE AL PIANO. INSTALLAZIONE DEI MODELLI A INDUZIONE CON VETRO SILICONATO A LIVELLO DEL PIANO SENZA TELAIO D'INGOMBRO. PREVISTO VANO CON GRIGLIA E FILTRO SMONTABILE PER L'AERAZIONE DEL GENERATORE INDUZIONE. PORTE TAMBURATE E SALDATE, RINFORZATE ALL'INTERNO CON POLISTIROLO AD ALTA DENSITÀ. È PRESENTE UN VANO TECNICO SPECIFICO, DI FACILE ISPEZIONE, PER LA SCATOLA ELETTRICA CHE CONTIENE TUTTI I COLLEGAMENTI. CASSETTI E PORTE DOTATE DI RALLENTATORE IN CHIUSURA. POSSIBILITÀ DI VANI ILLUMINATI DA STRIP LED CHE SI ATTIVA ALL'APERTURA DELLA PORTA RELATIVA TRAMITE "MICROSWITCH".**

**EN MONOBLOCCO 5.0.** The top is a single piece, the sides go down to the ground and are load-bearing. It's entirely in stainless steel AISI 304 CrNi 18/10, 3 mm thick with scratch-proof satin finish, reinforced with bolted crossbars. Structure and frame are entirely load-bearing. The drop-in elements can be installed as recessed and silicone fastened or they can be welded entirely to the top. Installation of the induction models with silicon-coated glass at the level of the top without a cumbersome frame. Includes compartment with grill and removable filter for the aeration of the induction generator. All the doors are hollow core and entirely welded, reinforced internally with high-density polystyrene. A specific technical compartment is present, allowing easy inspection of the electrical box that contains all the connections. Drawers and doors equipped with soft closure. Possibility of compartments illuminated by strip LEDs that turn on at the opening of the relative door by "microswitch".

• **DE MONOBLOCCO 5.0.** Die Platte ist aus einem einzigen Stück mit bis zum Boden tragenden Seiten, alle aus Edelstahl AISI 304 CrNi 18/10 mit kratzfester, satiniertes Oberfläche und einer Dicke von 3 mm, verstärkt mit verschraubten Querstreben. Struktur und Rahmen vollständig tragend. Die Drop-in-Elemente können versenkt und silikonisiert oder vollständig mit dem Boden verschweißt werden. Installation der Induktionsmodelle mit silikonisiertem Glas auf der Höhe der Oberseite ohne Rahmen. Ausgestattetes Fach mit Gitter und abnehmbarem Filter zur Belüftung des Induktionsgenerators. Türen wabenförmig gekernt und geschweißt, innen mit hochdichtem Polystyrol verstärkt. Es gibt einen speziellen, leicht zu inspizierenden Technikraum für den Elektrokasten, der alle Anschlüsse enthält. Schubladen und Türen, die mit einer Schließverzögerung ausgestattet sind. Möglichkeit von Fächern, die von Streifen-LEDs beleuchtet werden, die beim Öffnen der entsprechenden Tür mit Hilfe eines "microswitch" aktiviert werden.

• **FR MONOBLOCCO 5.0.** Le plan est une pièce unique avec les côtés qui arrivent jusqu'à terre et portants, le tout en acier inox AISI 304 CrNi 18/10 satiné anti-rayures et épaisseur de 3 mm, renforcé par des traverses vissées. Structure et châssis entièrement portants. Les éléments drop-in peuvent être installés encastrés et siliconés ou être soudés entièrement au plan. Installation des modèles à induction avec verre siliconé au niveau du plan sans structure encombrante. Un compartiment avec grille est prévu, ainsi qu'un filtre démontable pour l'aération du générateur à induction. Portes alvéolaires et soudées, renforcées à l'intérieur par du polystyrène à haute densité. Il y a un compartiment technique spécifique, d'inspection facile, pour le boîtier électrique qui contient tous les raccordements. Tiroirs et portes équipés de fermeture amortie. Possibilité de compartiments éclairés par bande led qui s'active à l'ouverture de la porte relative à travers un "microswitch".

• **ES MONOBLOCCO 5.0.** La parte superior es una sola pieza con laterales hasta el suelo que soportan la carga, todo en acero inoxidable AISI 304 CrNi 18/10 con acabado satinado resistente a los arañazos y 3 mm de espesor, reforzado con travesaños atornillados. Estructura y armazón que soportan completamente la carga. Los elementos drop-in pueden instalarse empotrados y siliconados o pueden soldarse completamente al suelo. Instalación de los modelos de inducción con vidrio siliconado a nivel de la parte superior sin marco. Compartimento provisto de rejilla y filtro extraíble para la ventilación del generador de inducción. Puertas huecas y soldadas, reforzadas por dentro con poliestireno de alta densidad. Hay un compartimento técnico específico, fácil de inspeccionar, para la caja eléctrica que contiene todas las conexiones. Cajones y puertas equipadas con retardador de cierre. Posibilidad de compartimentos iluminados por una tira de leds que se activa al abrir la puerta correspondiente mediante "microswitch".



MOD. \_\_\_\_\_  
COD. \_\_\_\_\_

DESCRIZIONE/DESCRIPTION/BEZEICHNUNG/DESCRIPTION/DESCRIPCIÓN  
DIMENSIONI/DIMENSIONS/ABMESSUNGEN/DIMENSIONS/DIMENSIONES

POTENZA/POWER/LEISTUNG/PUISSANCE/POTENCIA  
VOLTAGGIO/VOLTAGE/SPANNUNG/VOLTAGE/VOLTAJE

$\frac{kW}{kcal/h}$   $\frac{kw}{V\sim}$   
Hz

PREZZO/PRICE €  
PREIS/PRIX/PRECIO €  
KG / M<sup>3</sup>

**? A@ABLOC5A 5.0 4 VERSIONE ? A@ABLOC5A 5.0 B, CON PIANO IN PEZZO UNICO FINO ALLA COPERTURA DEL PANNELLO COMANDI E FIANCHI TERMINALI CHE ARRIVANO A TERRA SEPARATI. PER FACILITARNE IL TRASPORTO E LA MOVIMENTAZIONE PUR MANTENENDO L'ESTETICA DEL FREEBLOCK 5.0**

**EN** MONOBLOCCO 5.0 B version, that is, with a single piece top up to the level of the control panel and separate sides that come to the ground. To facilitate transport and handling while maintaining the aesthetics of MONOBLOCCO 5.0 • **DE** MONOBLOCCO Version 5.0 B, mit fugenfreiem Oberteil bis zur Höhe des Bedienfelds hinuntergezogen und separaten Seitenteilen die bis zum Boden reichen. Dies erleichtert den Transport und die Handhabung unter Beibehaltung der Ästhetik von MONOBLOCCO 5.0 • **FR** Version MONOBLOCCO 5.0 B, c'est-à-dire avec un haut monobloc jusqu'au niveau du panneau de commande et des côtés latéraux séparés qui atteignent le sol. Pour faciliter le transport et la manutention tout en conservant l'esthétique de MONOBLOCCO 5.0 • **ES** Versión MONOBLOCCO 5.0 B, es decir, con una sola pieza que se completa hasta el nivel del panel de control y laterales separados que llegan al suelo. Para facilitar el transporte y la manipulación manteniendo la estética de MONOBLOCCO 5.0



**? A@ABLOC5A 5.0 C VERSIONE ? A@ABLOC5A 5.0 C, CON PIANO IN PEZZO UNICO SOLO SUPERIORE CON SBORDO LATERALE DI CM.7,5, PANNELLO COMANDI E FIANCATA TAMBURATA IN ESTETICA CON IL LATO FRONTALE.**

**EN** MONOBLOCCO 5.0 C version, that is, with a single piece top only with a lateral edge of 7.5 cm, a control panel and a side panel in aesthetics with the front side. • **DE** MONOBLOCCO Version 5.0 C, mit fugenfreiem Oberteil und seitlichem Überstand von 7,5 cm. Bedienfeld und doppelwandige Seitenteile in selber Ästhetik wie die Gerätefront. • **FR** Version MONOBLOCCO 5.0 C, c'est-à-dire avec un dessus monobloc uniquement avec un bord latéral de 7,5 cm, un panneau de commande et un panneau latéral en esthétique avec la face avant. • **ES** Versión MONOBLOCCO 5.0 C, es decir, con una parte superior de una sola pieza con un borde lateral de 7,5 cm, un panel de control y lateral en estética con el lado frontal



MOD. \_\_\_\_\_  
COD. \_\_\_\_\_

DESCRIZIONE/DESCRIPTION/BEZEICHNUNG/DESCRIPTION/DESCRIPCIÓN  
DIMENSIONI/DIMENSIONS/ABMESSUNGEN/DIMENSIONS/DIMENSIONES

POTENZA/POWER/LEISTUNG/PUISSANCE/POTENCIA  
VOLTAGGIO/VOLTAGE/SPANNUNG/VOLTAGE/VOLTAJE

⚡ kW kcal/h  
⚡ V~ Hz

PREZZO/PRICE €  
PREIS/PRIX/PRECIO  
KG / M<sup>3</sup>

**PTM-POTS**

**STRUTTURA PORTATEGAMI PER MONOBLOCCO (REALIZZAZIONI A PROGETTO)**

EN pot rack structure for monoblock (realizations for project) • DE Ablagerost für Kochwerkzeuge, für monoblock (Realisierungen im Projekt) • FR structures porte casseroles pour monobloc (réalisations en projet) • ES estructuras superiores porta cazuelas para monobloc (logros en el proyecto)  
**cm. ...x 70x 76,5h**



- /

**PTM-POTS-SL**

**STRUTTURA PORTATEGAMI PER MONOBLOCCO CON ABBASSAMENTO PORTASALAMANDRA (REALIZZAZIONI A PROGETTO)**

EN pot rack structure for monoblock with salamander support (realizations for project) • DE Ablagerost für Kochwerkzeuge, für monoblock mit Salamander Konsolen (Realisierungen im Projekt) • FR structures porte casseroles pour monobloc avec porte salamandres (réalisations en projet) • ES estructuras superiores porta cazuelas para monobloc con porta salamandra (logros en el proyecto)  
**cm. ...x 70x 76,5h**



- /

**PSM-SL**

**SUPPORTO SALAMANDRA PER MONOBLOCCO**

EN salamander support, for monoblock • DE Salamander Konsolen, für monoblock • FR porte salamandres pour monobloc • ES porta salamandra para monobloc  
**cm. 60x 50x 40h**



**694,00**  
10 / 0,20

**SCHUKO**  
537060400

**PRESA ELETTRICA SCHUKO 230V~ / 16A IN PLASTICA GRIGIA IP44**

EN Schuko electrical outlet, 230V~ / 16A gray plastic IP44 • DE Schuko Steckdose, 230V~ / 16A grauer Kunststoff IP44 • FR prise de courant Schuko, 230V~ / 16A plastique gris IP44 • ES toma de corriente eléctrica schuko, 230V~ / 16A de plástico gris IP44  
**cm. 9x 9x 3**



**161,00**  
0.3 / 0,00

**SCHUKOS**  
537061600

**PRESA ELETTRICA SCHUKO 230V~ / 16A IN METALLO CROMATO IP54**

EN Schuko electrical outlet, 230V~ / 16A chromed metal IP54 • DE Schuko Steckdose, 230V~ / 16A métal chromé IP54 • FR prise de courant Schuko, 230V~ / 16A verchromtes Metall IP54 • ES toma de corriente eléctrica schuko, 230V~ / 16A de metal cromado IP54  
**cm. 8x 8x 4,5**



**340,00**  
0.3 / 0,00

**CEAMS**  
19580012

**COLONNA EROGAZIONE ACQUA CALDA E FREDDA CON CANNA SNODABILE, PER MONOBLOCCO**

EN Pillar tap, hot and cold water • DE Mischbatterie, Warm-und Kaltwasser • FR Colonne de distribution eau froide et chaude • ES Rubineto dispensador de agua caliente y fría  
**cm. 12x 12x 68h**



**544,00**  
6 / 0,03



MOD. \_\_\_\_\_  
COD. \_\_\_\_\_

DESCRIZIONE/DESCRIPTION/BEZEICHNUNG/DESCRIPTION/DESCRIPCIÓN  
DIMENSIONI/DIMENSIONS/ABMESSUNGEN/DIMENSIONS/DIMENSIONES

POTENZA/POWER/LEISTUNG/PUISSANCE/POTENCIA  
VOLTAGGIO/VOLTAGE/SPANNUNG/VOLTAGE/VOLTAJE

⚡ kW  
kcal/h

⚡ kW  
V~  
Hz

PREZZO/PRICE €  
PREIS/PRIX/PRECIO €  
KG / M<sup>3</sup>

**TOWER**  
1958001A

**COLONNA DI SERVIZIO: CORPO INOX CM.12X12X25H CON 2 PRESE ELETTRICHE MOD: SCHUKOS, PROFILO FERMA UTENSILI/ MIXER CON BACINELLA GN1/6 INFERIORE, RUBINETTO ACQUA CALDA E FREDDA CON CANNA SNODABILE CON ANTIGOCIA.**

**EN** Service Tower: inox body cm.12x12x25h with 2 electrical outlet mod: SCHUKOS, bracket for tools/mixer block with GN1/6 container inferior, Pillar tap with hot and cold water with dripless. • **DE** : Servicemöbel: Körper aus rostfreiem Stahl cm.12x12x25h mit 2 Steckdosen Mod: SCHUKOS, Werkzeug-/ Mischhalterprofil mit GN1/6 Bodenbecken, Warm- und Kaltwasserhahn mit Gelenkrohr mit Tropfschutz. • **FR** colonne de service : corps inox cm.12x12x25h avec 2 prises électriques mod : SCHUKOS, profil bloque ustensiles/mixer avec bac GN1/6 inférieure, robinet eau chaude et froide avec douchette et système anti-gouttes. • **ES** columna de servicio: cuerpo de acero inoxidable cm.12x12x25h con 2 tomas eléctricas mod: SCHUKOS, perfil portaherramientas/mezclador con bandeja inferior GN1/6, grifo de agua caliente y fría con tubo articulado con antigoteo.  
**cm. 21x 27x 67h**



**1.690,00**  
13 /

**MP240VV**  
\_1534760

**MIXER AD IMMERSIONE MINI. VELOCITÀ VARIABILE DA 2000 A 12500 GIRI/MIN. COLTELLO, CAMPANA E FUSTO IN INOX LUNGO 240 MM.**

**EN** MIXER mini. Speed variator 2000/12500 rpm, inox The foot, blade and tube 240mm. • **DE** Stabmixer mini. Geschwindigkeitsvariator 2000/12500 rpm, Messer und Stab 240mm aus Edelstahl. • **FR** Mixer Plongeant mini. variateur de vitesse 2000/12500 rpm, Couteau et tube en inox 240mm. • **ES** TRITURADORES mini. Velocidad variable de 2000 a 12.500 rpm. Cuchilla, campana y tubo de acero inoxidable de una longitud de 240 mm.  
**cm. 15x 15x 54h**



⚡ 0,29 KW  
230V~ 50 Hz **520,00**  
2.5 / 1,00

**MPFRUSTA**  
\_6027333

**FRUSTA PER MIXER MP240**  
**EN** Whip for MP240 • **DE** Peitsche für MP240 • **FR** fouet pour MP240 • **ES** Batidor para MP240



**218,00**  
0.5 / 0,00

**BMD-64EM**  
26050410

**BAGNOMARIA MONOFASE VASCA PER GN 1/1 H.15**

**EN** Bain marie singlephase - Bowl for GN 1/1 h.15 • **DE** Wasserbäder einphasig - Becken GN 1/1 h.15 • **FR** Bain marie monophasé - Cuve GN 1/1 h.15 • **ES** Baño de maría monofásico - Cuba para GN 1/1 15h  
**cm. 40x 60x 30h**



⚡ 2,1 kW  
230V~ 50/60 Hz **849,00**  
18 / 0,13

# BAGNOMARIA ELETTRICI 60

MOD. \_\_\_\_\_  
COD. \_\_\_\_\_

DESCRIZIONE/DESCRIPTION/BEZEICHNUNG/DESCRIPTION/DESCRIPCIÓN  
DIMENSIONI/DIMENSIONS/ABMESSUNGEN/DIMENSIONS/DIMENSIONES

POTENZA/POWER/LEISTUNG/PUISSANCE/POTENCIA  
VOLTAGGIO/VOLTAGE/SPANNUNG/VOLTAGE/VOLTAJE

⚡ kW kcal/h  
V~ Hz

PREZZO/PRICE €  
PREIS/PRIX/PRECIO €  
KG / M<sup>3</sup>

**BMD-68ET** **BAGNOMARIA TRIFASE VASCA PER GN 2/1**  
26050830 **H.15**

**EN** Bain marie threephase - Bowl for GN 2/1 h.15  
• **DE** Wasserbäder Dreiphasig - Becken GN 2/1 h.15  
• **FR** Bain marie triphase - Cuve GN 2/1 h.15 • **ES**  
Baño de maría trifásico. - Cuba para GN 2/1 15h  
**cm. 80x 60x 30h**



⚡ 4,2 kW **1.405,00**  
400V~2N 40 / 0,22  
230V~3  
50/60 Hz

**BMD-82EM** **BAGNOMARIA MONOFASE VASCA PER 7XGN**  
28050210 **1/9 H15**

**EN** Bain marie singlephase - Bowl for 7xGN 1/9 h.15  
• **DE** Wasserbäder einphasig - Becken für 7xGN 1/9  
h.15 • **FR** Bain marie monophasé - Cuve pour 7xGN  
1/9 h.15 • **ES** Baño de maría monofásico - Cuba para  
7xGN 1/9 h.15  
**cm. 20x 80x 30h**



⚡ 1,65 kW **1.120,00**  
230V~ 16 / 0,17  
50/60 Hz

**BMD-84EM** **BAGNOMARIA MONOFASE VASCA PER GN**  
28050410 **1/1 + GN 1/3 H15**

**EN** Bain marie singlephase - Bowl for GN 1/1 + GN  
1/3 h.15 • **DE** Wasserbäder einphasig - Becken GN  
1/1 + GN 1/3 h.15 • **FR** Bain marie monophasé -  
Cuve GN 1/1 + GN 1/3 h.15 • **ES** Baño de maría  
monofásico - Cuba para GN 1/1 + GN 1/3 15h  
**cm. 40x 80x 30h**



⚡ 2,85 kW **1.359,00**  
230V~ 21 / 0,23  
50/60 Hz

**BSD-64EM** **CONTENITORE CALDO CON INFRAROSSO**  
26040410 **MONOFASE VASCA CM. 30,5X51X16,5H CON**  
**FALSO FONDO FORATO**

**EN** Fry dump singlephase with infra-red heater. Bowl  
cm. 30,5x51x16,5h with perforated double bottom  
• **DE** Frittenwanne Einphasig mit Infrarot-strahler.  
Becke cm. 30,5x51x16,5h mit gelochtem Bodenrost  
• **FR** Silo a frites monophasé avec infrarouge. Cuve  
cm 30,5x51x16,5h avec double-fond perforé. • **ES**  
Contenedor caliente por infrarrojo monofásico. Cuba  
cm. 30,5x51x16,5h con falso fondo agujereado  
**cm. 40x 60x 25h**



⚡ 1,47 kW **945,00**  
230V~ 20 / 0,13  
50/60 Hz

**BRFD-64ET** **BRASIERA FISSA MULTIFUNZIONALE ELETTRICA**  
26070433 **VASCA CM. 30X51X10H**

**EN** Electric multi-function fixed braising pan - Bowl cm.  
30x51x10h • **DE** Elektrische Multifunktionsbratpfanne  
Fest Becken cm. 30x51x10h • **FR** Sauteuse fixe  
multifonction électrique - Cuve cm. 30x51x10h • **ES**  
Sarten fija multifunción eléctrica - Cuba cm. 30x51x10h  
**cm. 40x 60x 28h**



⚡ 4 kW **2.083,00**  
400V~2N 45 / 0,13  
230V~3  
50/60 Hz

**BRFD-68ET** **BRASIERA FISSA MULTIFUNZIONALE ELETTRICA**  
26070833 **VASCA CM. 70X51X10H**

**EN** Electric multi-function fixed braising pan - Bowl cm.  
70x51x10h • **DE** Elektrische Multifunktionsbratpfanne  
Fest Becken cm. 70x51x10h • **FR** Sauteuse fixe  
multifonction électrique - Cuve cm. 70x51x10h • **ES**  
Sarten fija multifunción eléctrica - Cuba cm. 70x51x10h  
**cm. 80x 60x 28h**



⚡ 8 kW **3.679,00**  
400V~3N 65 / 0,32  
50/60 Hz

# BRASIERE FISSE MULTIFUNZIONE ELETTRICHE 80

MOD. \_\_\_\_\_  
COD. \_\_\_\_\_

DESCRIZIONE/DESCRIPTION/BEZEICHNUNG/DESCRIPTION/DESCRIPCIÓN  
DIMENSIONI/DIMENSIONS/ABMESSUNGEN/DIMENSIONS/DIMENSIONES

POTENZA/POWER/LEISTUNG/PUISSANCE/POTENCIA  
VOLTAGGIO/VOLTAGE/SPANNUNG/VOLTAGE/VOLTAJE

⚡ kW  
kcal/h

⚡ kw  
V~  
Hz

PREZZO/PRICE €  
PREIS/PRIX/PRECIO €  
KG / M<sup>3</sup>

**BRFD-84ET**  
28070433

## BRASIERA FISSA MULTIFUNZIONALE ELETTRICA VASCA CM. 30X68X10H

**EN** Electric multi-function fixed braising pan - Bowl cm. 30x68x10h • **DE** Elektrische Multifunktionsbratpfanne Fest Becken cm. 30x68x10h • **FR** Sauteuse fixe multifonction électrique - Cuve cm. 30x68x10h • **ES** Sartén fija multifunción eléctrica - Cuba cm. 30x68x10g  
**cm. 40x 80x 28h**



⚡ 5,2 kW  
400V~2N  
50/60 Hz

**2.293,00**  
60 / 0,23

**CPD-64ET**  
26100430

## CUOCIPASTA TRIFASE LT. 25 VASCA CM. 30,5X33,5X32,7H. RUBINETTO CARICO ACQUA, SFIORATORE + SCARICO A PAVIMENTO. (CESTI ESCLUSI)

**EN** Pasta cooker threephase 25 lts. Tank cm. 30,5x33,5x32,7h. Water loading cock + overflow device and floor draining (BASKETS EXCLUDED) • **DE** Nudelkocher Dreiphasig lt. 25. Becken cm. 30,5x33,5x32,7h. Wasserlauf-Hahn, + Überlauf-Vorrichtung und Ablauf am Boden (KORB AUSGESCHLOSSEN) • **FR** Cuiseur à pates triphase lt. 25. Cuve cm.30,5x33,5x32,7h. Robinet d'arrivée d'eau trop plein + système de vidange au sol (PANIERS EXCLUS) • **ES** Cuece pasta trifásico lt. 25 - Cuba cm. 30,5x33,5x32,7h. Grifo carga agua + vertedero + descarga a pavimento (CESTAS EXCLUIDAS)  
**cm. 40x 60x 51h**



⚡ 7,8 kW  
400V~3N  
50/60 Hz

**1.839,00**  
22 / 0,24

### COMBINAZIONI

- Combinations / • Zusammenstellungen
- Combinaisons / • Combinación múltiple



**CPAD-64ET**  
26100435

## CUOCIPASTA TRIFASE LT. 25 VASCA CM. 30,5X33,5X32,7H. CARICO ACQUA AUTOMATICO CON SENSORE DI LIVELLO - SFIORATORE + SCARICO A PAVIMENTO (CESTI ESCLUSI)

**EN** Pasta cooker threephase 25 lts. Tank cm. 30,5x33,5x32,7h. Automatic Water loading with level sensor - overflow device and floor draining (BASKETS EXCLUDED) • **DE** Nudelkocher Dreiphasig lt. 25. Becken cm. 30,5x33,5x32,7h. Automatische Wasser Beladung mit Niveauregulierung + Überlauf-Vorrichtung und Ablauf am Boden (KORB AUSGESCHLOSSEN) • **FR** Cuiseur à pates triphase lt. 25. Cuve cm.30,5x33,5x32,7h. Chargement automatique de l'eau avec sensor de niveau, trop plein Système de vidange au sol (PANIERS EXCLUS) • **ES** Cuece pasta trifásico lt. 25 - Cuba cm. 30,5x33,5x32,7h. Carga automática de agua con sensor de nivel + vertedero + descarga a pavimento. (CESTAS EXCLUIDAS)  
**cm. 40x 60x 51h**



⚡ 7,8 kW  
400V~3N  
50/60 Hz

**2.224,00**  
22 / 0,24

### COMBINAZIONI

- Combinations / • Zusammenstellungen
- Combinaisons / • Combinación múltiple



Le immagini presentate non sono vincolanti. La ditta si riserva di apportare modifiche senza preavviso. • The pictures are purely representative. The manufacturer reserves the right to modify the technical data and models without previous notice. • Les images

LO

présentées ne nous engagent pas. La Société se réserve le droit d'apporter tout modification sans préavis. • Die dargestellten Abbildungen sind nicht verbindlich. Technische Änderungen vorbehalten. • Las imágenes presentadas no son vinculantes. El Fabricante se reserva el derecho de modificar sus productos sin previo aviso.

01/20

341

MOD. \_\_\_\_\_  
COD. \_\_\_\_\_

DESCRIZIONE/DESCRIPTION/BEZEICHNUNG/DESCRIPTION/DESCRIPCIÓN  
DIMENSIONI/DIMENSIONS/ABMESSUNGEN/DIMENSIONS/DIMENSIONES

POTENZA/POWER/LEISTUNG/PUISSANCE/POTENCIA  
VOLTAGGIO/VOLTAGE/SPANNUNG/VOLTAGE/VOLTAJE

⚡ kW kcal/h  
V~ Hz

PREZZO/PRICE €  
PREIS/PRIX/PRECIO  
KG / M<sup>3</sup>

**CPD-84ET**  
28100430

**CUOCIPASTA TRIFASE LT. 40 VASCA CM. 30,7X50,9X32,7H. RUBINETTO CARICO ACQUA, SFIORATORE + SCARICO A PAVIMENTO (CESTI ESCLUSI)**  
**EN** Pasta cooker threephase 40 lts. Tank cm. 30,7x50,9x32,7h. Water loading tap + overflow device and floor draining (BASKETS EXCLUDED) • **DE** Nudelkocher dreiphasig lt. 40 - Becken cm. 30,7x50,9x32,7h. Wasserlauf-Hahn + Überlauf-Vorrichtung und Ablauf am Boden (KORB AUSGESCHLOSSEN) • **FR** Cuiseur a pates triphase lt. 40 Cuve cm.30,7x50,9x32,7h. Robinet d'arrivée d'eau trop plein + système de vidange au sol (PANIERS EXCLUS) • **ES** Cuece pasta trifásico lt. 40 - Cuba cm. 30,7x50,9x32,7h. Grifo carga agua + vertedero + descarga a pavimento (CESTAS EXCLUIDAS)  
**cm. 40x 80x 51h**



⚡ 13,5 kW **2.252,00**  
400V~3N 30 / 0,26  
50/60 Hz

### COMBINAZIONI

- Combinations / • Zusammenstellungen
- Combinaisons / • Combinación múltiple

1/1	1/2	1/3	1/3	1/6 1/6	1/6 1/6
	1/2	1/3	2/3	1/3	1/6 1/6
		1/3		1/3	1/6 1/6

**CPAD-84ET**  
28100435

**CUOCIPASTA TRIFASE LT. 40 VASCA CM. 30,7X50,9X32,7H. CARICO ACQUA AUTOMATICO CON SENSORE DI LIVELLO - SFIORATORE + SCARICO A PAVIMENTO (CESTI ESCLUSI)**  
**EN** Pasta cooker threephase 40 lts. Tank cm. 30,7x50,9x32,7h. Automatic Water loading with level sensor - overflow device and floor draining (BASKETS EXCLUDED) • **DE** Nudelkocher dreiphasig lt. 40 - Becken cm. 30,7x50,9x32,7h. Automatische Wasser Beladung mit Niveaugulierung + Überlauf-Vorrichtung und Ablauf am Boden (KORB AUSGESCHLOSSEN) • **FR** Cuiseur a pates triphase lt. 40 Cuve cm.30,7x50,9x32,7h. Chargement automatique de l'eau avec sensor de niveau, trop plein Système de vidange au sol (PANIERS EXCLUS) • **ES** Cuece pasta trifásico lt. 40 - Cuba cm. 30,7x50,9x32,7h. Carga automática de agua con sensor de nivel + vertedero + descarga a pavimento. (CESTAS EXCLUIDAS)  
**cm. 40x 80x 51h**



⚡ 13,5 kW **2.636,00**  
400V~3N 30 / 0,26  
50/60 Hz

### COMBINAZIONI

- Combinations / • Zusammenstellungen
- Combinaisons / • Combinación múltiple

1/1	1/2	1/3	1/3	1/6 1/6	1/6 1/6
	1/2	1/3	2/3	1/3	1/6 1/6
		1/3		1/3	1/6 1/6

**CWKD-64ET**  
26080431

**GRIGLIA CONTACT - COTTURA DIRETTA SU RESISTENZA IN ACCIAIO INOX CM. 27X43 RIBALTABILE**  
**EN** CONTACT Grill threephase - rotatable stainless steel grill cm. 27x43 • **DE** Würstbrater dreiphasig KONTAKT - Drehbaren Heizelement aus Edelstahl cm. 27x43 • **FR** Grillade triphase CONTACT - Grille inox rotatif cm 27x43 • **ES** Parrilla trifásico CONTACT - Parrilla giratoria de acero inox cm 27x43  
**cm. 40x 60x 30h**



⚡ 4,08 kW **2.295,00**  
400V~3N 30 / 0,16  
50/60 Hz



# GRIGLIE ELETTRICHE 60

MOD. \_\_\_\_\_  
COD. \_\_\_\_\_

DESCRIZIONE/DESCRIPTION/BEZEICHNUNG/DESCRIPTION/DESCRIPCIÓN  
DIMENSIONI/DIMENSIONS/ABMESSUNGEN/DIMENSIONS/DIMENSIONES

POTENZA/POWER/LEISTUNG/PUISSANCE/POTENCIA  
VOLTAGGIO/VOLTAGE/SPANNUNG/VOLTAGE/VOLTAJE

⚡ kW  
kcal/h  
V~  
Hz

PREZZO/PRICE €  
PREIS/PRIX/PRECIO  
KG / M<sup>3</sup>

**CWKD-68ET GRIGLIA CONTACT - COTTURA DIRETTA SU RESISTENZA IN ACCIAIO INOX CM. 55X43 RIBALTABILE - 2 ZONE COTTURA**

26080831

**EN** CONTACT Grill threephase - rotatable stainless steel grill cm. 55x43 - 2 cooking areas • **DE** Wurstbrater dreiphasig KONTAKT - Drehbaren Heizelement aus Edelstahl cm. 55x43 - 2 Heizzonen • **FR** Grillade triphase CONTACT - Grille inox rotatif cm 55x43 - 2 zones de cuisson • **ES** Parrilla trifásico CONTACT - Parrilla giratoria de acero inox cm 55x43 - 2 zonas de cocción  
**cm. 80x 60x 30h**



⚡ 8,16 kW  
400V~3N  
50/60 Hz

**3.118,00**  
60 / 0,31

**CWKD-84ET GRIGLIA CONTACT - COTTURA DIRETTA SU RESISTENZA IN ACCIAIO INOX CM. 27X63 RIBALTABILE**

28080431

**EN** CONTACT Grill threephase - rotatable stainless steel grill cm. 27x63 • **DE** Wurstbrater dreiphasig KONTAKT - Drehbaren Heizelement aus Edelstahl cm. 27x63 • **FR** Grillade triphase CONTACT - Grille inox rotatif cm 27x63 • **ES** Parrilla trifásico CONTACT - Parrilla giratoria de acero inox cm 27x63  
**cm. 40x 80x 30h**



⚡ 5,415 kW  
400V~3N  
50/60 Hz

**2.685,00**  
35 / 0,23

**F2/8D-64ET FRIGGITRICE TRIFASE LT. 8+8 2 VASCHE CM. 14,8X35X32,7H - 2 CESTI CM. 12X30X15H - FILTRO E COPERCHIO VASCA. PRODUZIONE PATATE: 12 KG/H**

26090432

**EN** Fryer threephase 8+8 lts - 2 Bowls cm. 14,8x35x32,7h - 2 baskets cm. 12x30x15h. Sieve and lid for pan. Production: 12 kg/h • **DE** Friteuse dreiphasig lt. 8+8 - 2 Becken cm. 14,8x35x32,7h - 2 Korb cm. 12x30x15h. Einlegesieb und Deckel für Becken. Pommes frites: 12 kg/h • **FR** Friteuse triphase lt. 8+8 - 2 Cuve cm. 14,8x35x32,7h - 2 Panier cm. 12x30x15h. Filtre, couvercle pour cuve. Production de pommes frites: 12 kg/h • **ES** Freidoras trifásico 8+8 lt. - 2Cuba cm. 14,8x35x32,7h- 2 cesta cm. 12x30x15h. Filtro y tapa para cuba. Prod. patatas: 12 Kg/h  
**cm. 40x 60x 46h**



⚡ 12 kW  
400V~3N  
230V~3  
50/60 Hz

**2.323,00**  
30 / 0,23

**F10D-64ET FRIGGITRICE TRIFASE LT. 10 VASCA CM. 22X35X23H - 1 CESTO CM. 20X30X10H - FILTRO E COPERCHIO VASCA. PRODUZIONE PATATE: 10 KG/H**

26090430

**EN** Fryer threephase 10 lts - Bowl cm. 22x35x23h - 1 basket cm. 20x30x10h. Sieve and lid for pan. Production: 10 kg/h • **DE** Friteuse dreiphasig lt. 10 - Becken cm. 22x35x23h - 1 Korb cm. 20x30x10h. Einlegesieb und Deckel für Becken. Pommes frites: 10 kg/h • **FR** Friteuse triphase lt. 10 - Cuve cm. 22x35x23h - 1 Panier cm. 20x30x10h. Filtre, couvercle pour cuve. Production de pommes frites: 10 kg/h • **ES** Freidoras trifásico 10 lt. - Cuba cm. 22x35x23h - 1 cesta cm. 20x30x10h. Filtro y tapa para cuba. Prod. patatas: 10 Kg/h  
**cm. 40x 60x 39h**



⚡ 7,15 kW  
400V~3N  
230V~3  
50/60 Hz

**1.287,00**  
20 / 0,24

**F2/10D-66ET FRIGGITRICE TRIFASE LT. 10+10 2 VASCHE CM. 22X35X23H - 2 CESTI CM. 20X30X10H - FILTRO E COPERCHIO VASCA. PRODUZIONE PATATE: 20 KG/H**

26090630

**EN** Fryer threephase 10+10 lts - 2 Bowls cm. 22x35x23h - 2 baskets cm. 20x30x10h. Sieve and lid for pan. Production: 20 kg/h • **DE** Friteuse dreiphasig lt. 10+10 - 2 Becken cm. 22x35x23h - 2 Korb cm. 20x30x10h. Einlegesieb und Deckel für Becken. Pommes frites: 20 kg/h • **FR** Friteuse triphase lt. 10+10 - 2 Cuve cm. 22x35x23h - 2 Panier cm. 20x30x10h. Filtre, couvercle pour cuve. Production de pommes frites: 20 kg/h • **ES** Freidoras trifásico 10+10 lt. - 2Cuba cm. 22x35x23h- 2 cesta cm. 20x30x10h. Filtro y tapa para cuba. Prod. patatas: 20 kg/h  
**cm. 60x 60x 39h**



⚡ 14,3 kW  
400V~3N  
230V~3  
50/60 Hz

**2.355,00**  
32 / 0,27



Le immagini presentate non sono vincolanti. La ditta si riserva di apportare modifiche senza preavviso. • The pictures are purely representative. The manufacturer reserves the right to modify the technical data and models without previous notice. • Les images

LO

présentées ne nous engagent pas. La Société se réserve le droit d'apporter tout modification sans préavis. • Die dargestellten Abbildungen sind nicht verbindlich. Technische Änderungen vorbehalten. • Las imágenes presentadas no son vinculantes. El Fabricante se reserva el derecho de modificar sus productos sin previo aviso.

01/20

**343**



# FRIGGITRICI ELETTRICHE 60

MOD. \_\_\_\_\_  
COD. \_\_\_\_\_

DESCRIZIONE/DESCRIPTION/BEZEICHNUNG/DESCRIPTION/DESCRIPCIÓN  
DIMENSIONI/DIMENSIONS/ABMESSUNGEN/DIMENSIONS/DIMENSIONES

POTENZA/POWER/LEISTUNG/PUISSANCE/POTENCIA  
VOLTAGGIO/VOLTAGE/SPANNUNG/VOLTAGE/VOLTAJE

⚡ kW kcal/h  
⚡ kW V~ Hz

PREZZO/PRICE €  
PREIS/PRIX/PRECIO €  
KG / M<sup>3</sup>

**F18D-64ET**  
26090431

**FRIGGITRICE TRIFASE LT. 18 VASCA CM. 31X34X33H - 1 CESTO CM. 28X29X15H - FILTRO E COPERCHIO VASCA. PRODUZIONE PATATE: 15 KG/H**

EN Fryer threephase 18 lts - Bowl cm. 31x34x33h - 1 basket cm. 28x29x15h. Sieve and lid for pan. Production: 15 kg/h • DE Friteuse dreiphasig lt. 18 - Becken cm. 31x34x33h - 1 Korb cm. 28x29x15h. Einlegesieb und Deckel für Becken. Pommes frites: 15 kg/h • FR Friteuse triphase lt. 18 - Cuve cm. 31x34x33h - 1 Panier cm. 28x29x15h. Filtre, couvercle pour cuve. Production de pommes frites: 15 kg/h • ES Freidoras trifásico 18 lt. - Cuba cm. 31x34x33h - 1 cesta cm. 28x29x15h. Filtro y tapa para cuba. Prod. patatas: 15 Kg/h  
**cm. 40x 60x 46h**



⚡ 15,9 kW **1.874,00**  
400V~3N 30 / 0,23  
50/60 Hz

**F23D-66ET**  
26090631

**FRIGGITRICE TRIFASE LT. 23 VASCA CM. 50X35X22H - CESTO CM. 46X30X10H - FILTRO E COPERCHIO VASCA.**

EN Fryer threephase 23 lts - Bowls cm. 50x35x24h - Basket cm. 46x30x10h - Sieve and lid for pan. • DE Friteuse dreiphasig lt. 23 - Becken cm. 50x35x22h - Korb cm. 46x30x10h - Einlegesieb und Deckel für Becken. • FR Friteuse triphase lt. 23 - Cuve cm. 50x35x22h - Panier cm 46x30x10h - Filtre, couvercle pour cuve. • ES Freidoras trifásico 23 lt. cuba cm. 50x35x22h - Cesta cm. 46x30x10h - Filtro y tapa para cuba.  
**cm. 60x 60x 39h**



⚡ 14,3 kW **1.899,00**  
400V~3N 31 / 0,27  
50/60 Hz

**FTLD-64ET**  
26060431

**FRY-TOP ELETTRICO LISCIO, PIASTRA CM.35,5X55**

EN Electric Fry-top smooth griddle, plate cm.35,5x55  
• DE Griddleplatte elektrische glatt, platte cm.35,5x55  
• FR Plaque électriques lisse, plaque cm.35,5x55 • ES Fry-top eléctrico liso, plancha cm.35,5x55  
**cm. 40x 60x 22h**

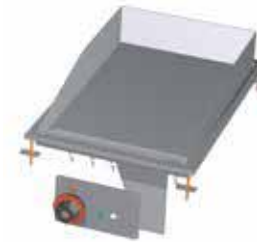

⚡ 4,5 kW **1.103,00**  
400V~3N 30 / 0,13  
230V~3  
50/60 Hz

**FTLD-64ETS**  
26060434

**FRY-TOP ELETTRICO LISCIO CROMATO SUPERCHROME (MOCA APPROVED), PIASTRA CM.35,5X55**

EN Electric Fry-top smooth chromed griddle SUPERCHROME (Moca Approved), plate cm.35,5x55  
• DE Griddleplatte elektrische glatt hartverchromt SUPERCHROME (Moca Approved), platte cm.35,5x55  
• FR Plaque électriques lisse chromée SUPERCHROME (Moca Approved), plaque cm.35,5x55 • ES Fry-top eléctrico liso cromado SUPERCHROME (Moca Approved), plancha cm.35,5x55  
**cm. 40x 60x 22h**



⚡ 4,5 kW **1.379,00**  
400V~3N 30 / 0,13  
230V~3  
50/60 Hz

**FTRD-64ET**  
26060433

**FRY-TOP ELETTRICO RIGATO, PIASTRA CM.35,5X55**

EN Electric Fry-top grooved griddle, plate cm.35,5x55  
• DE Griddleplatte elektrische gerillt, platte cm.35,5x55  
• FR Plaque électriques nervurée, plaque cm.35,5x55  
• ES Fry-top eléctrico estriado, plancha cm.35,5x55  
**cm. 40x 60x 22h**

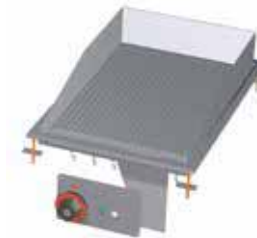

⚡ 4,5 kW **1.107,00**  
400V~3N 30 / 0,13  
230V~3  
50/60 Hz

# FRY-TOP ELETTRICI 60

MOD. \_\_\_\_\_  
COD. \_\_\_\_\_

DESCRIZIONE/DESCRIPTION/BEZEICHNUNG/DESCRIPTION/DESCRIPCIÓN  
DIMENSIONI/DIMENSIONS/ABMESSUNGEN/DIMENSIONS/DIMENSIONES

POTENZA/POWER/LEISTUNG/PUISSANCE/POTENCIA  
VOLTAGGIO/VOLTAGE/SPANNUNG/VOLTAGE/VOLTAJE

⚡ kW \_\_\_\_\_  
kcal/h \_\_\_\_\_  
V~ \_\_\_\_\_  
Hz \_\_\_\_\_

PREZZO/PRICE € \_\_\_\_\_  
PREIS/PRIX/PRECIO € \_\_\_\_\_  
KG / M<sup>3</sup> \_\_\_\_\_

**FTRD-64ETS FRY-TOP ELETTRICO RIGATO CROMATO SUPERCHROME (MOCA APPROVED), PIASTRA CM.35,5X55**

26060436

**EN** Electric Fry-top grooved chromed griddle SUPERCHROME (Moca Approved), plate cm.35,5x55 • **DE** Griddleplatte elektrische gerillt hartverchromt SUPERCHROME (Moca Approved), platte cm.35,5x55 • **FR** Plaque électriques nervurée chromée SUPERCHROME (Moca Approved), plaque cm.35,5x55 • **ES** Fry-top eléctrico estriado cromado SUPERCHROME (Moca Approved), plancha cm.35,5x55  
**cm. 40x 60x 22h**

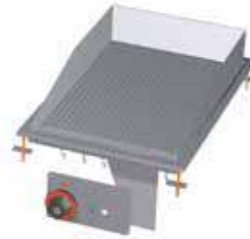

⚡ 4,5 kW \_\_\_\_\_ **1.438,00**  
400V~3N \_\_\_\_\_ 30 / 0,13  
230V~3 \_\_\_\_\_  
50/60 Hz \_\_\_\_\_



**FTLD-66ET FRY-TOP ELETTRICO LISCIO, PIASTRA CM.55,5X55 - 2 ZONE DI COTTURA**

26060631

**EN** Electric Fry-top smooth griddle, plate cm.55,5x55 - 2 cooking areas • **DE** Griddleplatte elektrische glatt, platte cm.55,5x55 - 2 Heizzonen • **FR** Plaque électriques lisse, plaque cm.55,5x55 - 2 zones de cuisson • **ES** Fry-top eléctrico liso, plancha cm.55,5x55 - 2 zonas de cocción  
**cm. 60x 60x 22h**



⚡ 6 kW \_\_\_\_\_ **1.408,00**  
400V~3N \_\_\_\_\_ 45 / 0,22  
230V~3 \_\_\_\_\_  
230V~ \_\_\_\_\_  
50/60 Hz \_\_\_\_\_



**FTLD-66ETS FRY-TOP ELETTRICO LISCIO CROMATO SUPERCHROME (MOCA APPROVED), PIASTRA CM.55,5X55 - 2 ZONE DI COTTURA**

26060634

**EN** Electric Fry-top smooth chromed griddle SUPERCHROME (Moca Approved), plate cm.55,5x55 - 2 cooking areas • **DE** Griddleplatte elektrische glatt hartverchromt SUPERCHROME (Moca Approved), platte cm.55,5x55 - 2 Heizzonen • **FR** Plaque électriques lisse chromée SUPERCHROME (Moca Approved), plaque cm.55,5x55 - 2 zones de cuisson • **ES** Fry-top eléctrico liso cromado SUPERCHROME (Moca Approved), plancha cm.55,5x55 - 2 zonas de cocción  
**cm. 60x 60x 22h**

⚡ 6 kW \_\_\_\_\_ **1.845,00**  
400V~3N \_\_\_\_\_ 45 / 0,22  
230V~3 \_\_\_\_\_  
230V~ \_\_\_\_\_  
50/60 Hz \_\_\_\_\_



**FTLRD-66ET FRY-TOP ELETTRICO 1/2 RIGATO + 1/2 LISCIO, PIASTRA CM.55,5X55 - 2 ZONE DI COTTURA**

26060632

**EN** Electric Fry-top 1/2 grooved + 1/2 smooth, plate cm.55,5x55 - 2 cooking areas • **DE** Griddleplatte elektrische 1/2 gerillt + 1/2 glatt, platte cm.55,5x55 - 2 Heizzonen • **FR** Plaque électriques 1/2 nervurée + 1/2 lisse, plaque cm.55,5x55 - 2 zones de cuisson • **ES** Fry-top eléctrico 1/2 estriado + 1/2 liso, plancha cm.55,5x55 - 2 zonas de cocción  
**cm. 60x 60x 22h**



⚡ 6 kW \_\_\_\_\_ **1.472,00**  
400V~3N \_\_\_\_\_ 45 / 0,22  
230V~3 \_\_\_\_\_  
230V~ \_\_\_\_\_  
50/60 Hz \_\_\_\_\_



**FTLRD-66ETS FRY-TOP ELETTRICO 1/2 RIGATO + 1/2 LISCIO CROMATO SUPERCHROME (MOCA APPROVED), PIASTRA CM.55,5X55 - 2 ZONE DI COTTURA**

26060635

**EN** Electric Fry-top 1/2 grooved + 1/2 smooth chromed griddle SUPERCHROME (Moca Approved), plate cm.55,5x55 - 2 cooking areas • **DE** Griddleplatte elektrische 1/2 gerillt + 1/2 glatt hartverchromt SUPERCHROME (Moca Approved), platte cm.55,5x55 - 2 Heizzonen • **FR** Plaque électriques 1/2 nervurée + 1/2 lisse chromée SUPERCHROME (Moca Approved), plaque cm.55,5x55 - 2 zones de cuisson • **ES** Fry-top eléctrico 1/2 estriado + 1/2 liso cromado SUPERCHROME (Moca Approved), plancha cm.55,5x55 - 2 zonas de cocción  
**cm. 60x 60x 22h**

⚡ 6 kW \_\_\_\_\_ **1.910,00**  
400V~3N \_\_\_\_\_ 45 / 0,22  
230V~3 \_\_\_\_\_  
230V~ \_\_\_\_\_  
50/60 Hz \_\_\_\_\_



Le immagini presentate non sono vincolanti. La ditta si riserva di apportare modifiche senza preavviso. • The pictures are purely representative. The manufacturer reserves the right to modify the technical data and models without previous notice. • Les images

LO

présentées ne nous engagent pas. La Société se réserve le droit d'apporter tout modification sans préavis. • Die dargestellten Abbildungen sind nicht verbindlich. Technische Änderungen vorbehalten. • Las imágenes presentadas no son vinculantes. El Fabricante se reserva el derecho de modificar sus productos sin previo aviso.

01/20

345

# FRY-TOP ELETTRICI 60

MOD. \_\_\_\_\_  
COD. \_\_\_\_\_

DESCRIZIONE/DESCRIPTION/BEZEICHNUNG/DESCRIPTION/DESCRIPCIÓN  
DIMENSIONI/DIMENSIONS/ABMESSUNGEN/DIMENSIONS/DIMENSIONES

POTENZA/POWER/LEISTUNG/PUISSANCE/POTENCIA  
VOLTAGGIO/VOLTAGE/SPANNUNG/VOLTAGE/VOLTAJE

⚡ kW kcal/h  
V~ Hz

PREZZO/PRICE €  
PREIS/PRIX/PRECIO €  
KG / M<sup>3</sup>

**FTRD-66ET**  
26060633

**FRY-TOP ELETTRICO RIGATO, PIASTRA CM.55,5X55 - 2 ZONE DI COTTURA**  
**EN** Electric Fry-top grooved griddle, plate cm.55,5x55 - 2 cooking areas • **DE** Griddleplatte elektrische gerillt, platte cm.55,5x55 - 2 Heizzonen • **FR** Plaque électriques nervurée, plaque cm.55,5x55 - 2 zones de cuisson • **ES** Fry-top eléctrico estriado, plancha cm.55,5x55 - 2 zonas de cocción  
**cm. 60x 60x 22h**

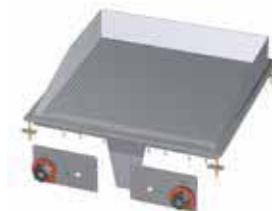

⚡ 6 kW 1.510,00  
400V~3N 45 / 0,22  
230V~3  
230V~  
50/60 Hz



**FTRD-66ETS**  
26060636

**FRY-TOP ELETTRICO RIGATO CROMATO SUPERCHROME (MOCA APPROVED), PIASTRA CM.55,5X55 - 2 ZONE DI COTTURA**  
**EN** Electric Fry-top grooved chromed griddle SUPERCHROME (Moca Approved), plate cm.55,5x55 - 2 cooking areas • **DE** Griddleplatte elektrische gerillt hartverchromt SUPERCHROME (Moca Approved), platte cm.55,5x55 - 2 Heizzonen • **FR** Plaque électriques nervurée chromée SUPERCHROME (Moca Approved), plaque cm.55,5x55 - 2 zones de cuisson • **ES** Fry-top eléctrico estriado cromado SUPERCHROME (Moca Approved), plancha cm.55,5x55 - 2 zonas de cocción  
**cm. 60x 60x 22h**

⚡ 6 kW 1.947,00  
400V~3N 45 / 0,22  
230V~3  
230V~  
50/60 Hz



**FTLD-68ET**  
26060831

**FRY-TOP ELETTRICO LISCIO, PIASTRA CM.75,5X55 - 2 ZONE DI COTTURA**  
**EN** Electric Fry-top smooth griddle, plate cm.75,5x55 - 2 cooking areas • **DE** Griddleplatte elektrische glatt, platte cm.75,5x55 - 2 Heizzonen • **FR** Plaque électriques lisse, plaque cm.75,5x55 - 2 zones de cuisson • **ES** Fry-top eléctrico liso, plancha cm.75,5x55 - 2 zonas de cocción  
**cm. 80x 60x 22h**



⚡ 9 kW 1.729,00  
400V~3N 60 / 0,32  
230V~3  
50/60 Hz

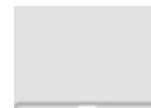

**FTLD-68ETS**  
26060834

**FRY-TOP ELETTRICO LISCIO CROMATO SUPERCHROME (MOCA APPROVED), PIASTRA CM.75,5X55 - 2 ZONE DI COTTURA**  
**EN** Electric Fry-top smooth chromed griddle SUPERCHROME (Moca Approved), plate cm.75,5x55 - 2 cooking areas • **DE** Griddleplatte elektrische glatt hartverchromt SUPERCHROME (Moca Approved), platte cm.75,5x55 - 2 Heizzonen • **FR** Plaque électriques lisse chromée SUPERCHROME (Moca Approved), plaque cm.75,5x55 - 2 zones de cuisson • **ES** Fry-top eléctrico liso cromado SUPERCHROME (Moca Approved), plancha cm.75,5x55 - 2 zonas de cocción  
**cm. 80x 60x 22h**

⚡ 9 kW 2.341,00  
400V~3N 60 / 0,32  
230V~3  
50/60 Hz



**FTLRD-68ET**  
26060832

**FRY-TOP ELETTRICO 1/2 RIGATO + 1/2 LISCIO, PIASTRA CM.75,5X55 - 2 ZONE DI COTTURA**  
**EN** Electric Fry-top 1/2 grooved + 1/2 smooth, plate cm.75,5x55 - 2 cooking areas • **DE** Griddleplatte elektrische 1/2 gerillt + 1/2 glatt, platte cm.75,5x55 - 2 Heizzonen • **FR** Plaque électriques 1/2 nervurée + 1/2 lisse, plaque cm.75,5x55 - 2 zones de cuisson • **ES** Fry-top eléctrico 1/2 estriado + 1/2 liso, plancha cm.75,5x55 - 2 zonas de cocción  
**cm. 80x 60x 22h**



⚡ 9 kW 1.790,00  
400V~3N 60 / 0,32  
230V~3  
50/60 Hz



# FRY-TOP ELETTRICI 60

MOD. \_\_\_\_\_  
COD. \_\_\_\_\_

DESCRIZIONE/DESCRIPTION/BEZEICHNUNG/DESCRIPTION/DESCRIPCIÓN  
DIMENSIONI/DIMENSIONS/ABMESSUNGEN/DIMENSIONS/DIMENSIONES

POTENZA/POWER/LEISTUNG/PUISSANCE/POTENCIA  
VOLTAGGIO/VOLTAGE/SPANNUNG/VOLTAGE/VOLTAJE

⚡ kW kcal/h  
V~ Hz

PREZZO/PRICE €  
PREIS/PRIX/PRECIO  
KG / M<sup>3</sup>

**FTRLD-68ETS FRY-TOP ELETTRICO 1/2 RIGATO + 1/2 LISCIO CROMATO SUPERCHROME (MOCA APPROVED), PIASTRA CM.75,5X55 - 2 ZONE DI COTTURA**

26060835

**EN** Electric Fry-top 1/2 grooved + 1/2 smooth chromed griddle SUPERCHROME (Moca Approved), plate cm.75,5x55 - 2 cooking areas • **DE** Griddleplatte elektrische 1/2 gerillt + 1/2 glatt hartverchromt SUPERCHROME (Moca Approved), platte cm.75,5x55 - 2 Heizzonen • **FR** Plaque électriques 1/2 nervurée + 1/2 lisse chromée SUPERCHROME (Moca Approved), plaque cm.75,5x55 - 2 zones de cuisson • **ES** Fry-top eléctrico 1/2 estriado + 1/2 liso cromado SUPERCHROME (Moca Approved), plancha cm.75,5x55 - 2 zonas de cocción  
**cm. 80x 60x 22h**



⚡ 9 kW **2.469,00**  
400V~3N 60 / 0,32  
230V~3  
50/60 Hz



**FTRD-68ET FRY-TOP ELETTRICO RIGATO, PIASTRA CM.75,5X55 - 2 ZONE DI COTTURA**

26060833

**EN** Electric Fry-top grooved griddle, plate cm.55,5x55 - 2 cooking areas • **DE** Griddleplatte elektrische gerillt, platte cm.55,5x55 - 2 Heizzonen • **FR** Plaque électriques nervurée, plaque cm.55,5x55 - 2 zones de cuisson • **ES** Fry-top eléctrico estriado, plancha cm.55,5x55 - 2 zonas de cocción  
**cm. 80x 60x 22h**



⚡ 9 kW **1.831,00**  
400V~3N 60 / 0,32  
230V~3  
50/60 Hz



**FTRD-68ETS FRY-TOP ELETTRICO RIGATO CROMATO SUPERCHROME (MOCA APPROVED), PIASTRA CM.75,5X55 - 2 ZONE DI COTTURA**

26060836

**EN** Electric Fry-top grooved chromed griddle SUPERCHROME (Moca Approved), plate cm.55,5x55 - 2 cooking areas • **DE** Griddleplatte elektrische gerillt hartverchromt SUPERCHROME (Moca Approved), platte cm.55,5x55 - 2 Heizzonen • **FR** Plaque électriques nervurée chromée SUPERCHROME (Moca Approved), plaque cm.55,5x55 - 2 zones de cuisson • **ES** Fry-top eléctrico estriado cromado SUPERCHROME (Moca Approved), plancha cm.55,5x55 - 2 zonas de cocción  
**cm. 80x 60x 22h**

⚡ 9 kW **2.442,00**  
400V~3N 60 / 0,32  
230V~3  
50/60 Hz



**FTLD-84ET FRY-TOP ELETTRICO LISCIO, PIASTRA CM.36X68**

28060431

**EN** Electric Fry-top smooth griddle, plate cm.36x68 • **DE** Griddleplatte elektrische glatt, platte cm.36x68 • **FR** Plaque électriques lisse, plaque cm.36x68 • **ES** Fry-top eléctrico liso, plancha cm.36x68  
**cm. 40x 80x 22h**



⚡ 15 kW **1.851,00**  
400V~3N 45 / 0,23  
50/60 Hz



**FTLD-84ETS FRY-TOP ELETTRICO LISCIO CROMATO SUPERCHROME (MOCA APPROVED), PIASTRA CM.36X68**

28060434

**EN** Electric Fry-top smooth chromed griddle SUPERCHROME (Moca Approved), plate cm.36x68 • **DE** Griddleplatte elektrische glatt hartverchromt SUPERCHROME (Moca Approved), platte cm.36x68 • **FR** Plaque électriques lisse chromée SUPERCHROME (Moca Approved), plaque cm.36x68 • **ES** Fry-top eléctrico liso cromado SUPERCHROME (Moca Approved), plancha cm.36x68  
**cm. 40x 80x 22h**

⚡ 15 kW **2.320,00**  
400V~3N 45 / 0,23  
50/60 Hz



**FTLD-88ET FRY-TOP ELETTRICO LISCIO, PIASTRA CM.76X68 - 2 ZONE DI COTTURA**

28060831

**EN** Electric Fry-top smooth griddle, plate cm.76x68 - 2 cooking areas • **DE** Griddleplatte elektrische glatt, platte cm.76x68 - 2 Heizzonen • **FR** Plaque électriques lisse, plaque cm.76x68 - 2 zones de cuisson • **ES** Fry-top eléctrico liso, plancha cm.76x68 - 2 zonas de cocción  
**cm. 80x 80x 22h**



⚡ 15 kW **2.742,00**  
400V~3N 90 / 0,44  
50/60 Hz

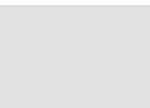

Le immagini presentate non sono vincolanti. La ditta si riserva di apportare modifiche senza preavviso. • The pictures are purely representative. The manufacturer reserves the right to modify the technical data and models without previous notice. • Les images

LO

présentées ne nous engagent pas. La Société se réserve le droit d'apporter tout modification sans préavis. • Die dargestellten Abbildungen sind nicht verbindlich. Technische Änderungen vorbehalten. • Las imágenes presentadas no son vinculantes. El Fabricante se reserva el derecho de modificar sus productos sin previo aviso.

01/20

347



# FRY-TOP ELETTRICI 80

MOD. \_\_\_\_\_  
COD. \_\_\_\_\_

DESCRIZIONE/DESCRIPTION/BEZEICHNUNG/DESCRIPTION/DESCRIPCIÓN  
DIMENSIONI/DIMENSIONS/ABMESSUNGEN/DIMENSIONS/DIMENSIONES

POTENZA/POWER/LEISTUNG/PUISSANCE/POTENCIA  
VOLTAGGIO/VOLTAGE/SPANNUNG/VOLTAGE/VOLTAJE

⚡ kW \_\_\_\_\_  
kcal/h \_\_\_\_\_  
V~ \_\_\_\_\_  
Hz \_\_\_\_\_

PREZZO/PRICE € \_\_\_\_\_  
PREIS/PRIX/PRECIO € \_\_\_\_\_  
KG / M<sup>3</sup> \_\_\_\_\_

**FTLD-88ETS**  
28060834

**FRY-TOP ELETTRICO LISCIO CROMATO SUPERCHROME (MOCA APPROVED), PIASTRA CM.76X68 - 2 ZONE DI COTTURA**  
**EN** Electric Fry-top smooth chromed griddle SUPERCHROME (Moca Approved), plate cm.76x68 - 2 cooking areas • **DE** Griddleplatte elektrische glatt hartverchromt SUPERCHROME (Moca Approved), platte cm.76x68 - 2 Heizzonen • **FR** Plaque électriques lisse chromée SUPERCHROME (Moca Approved), plaque cm.76x68 - 2 zones de cuisson • **ES** Fry-top eléctrico liso cromado SUPERCHROME (Moca Approved), plancha cm.76x68 - 2 zonas de cocción  
**cm. 80x 80x 22h**



⚡ 15 kW \_\_\_\_\_ **3.366,00**  
400V~3N \_\_\_\_\_ 90 / 0,44  
50/60 Hz \_\_\_\_\_

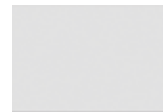

**FTLRD-88ET**  
28060832

**FRY-TOP ELETTRICO 1/2 RIGATO + 1/2 LISCIO, PIASTRA CM.76X68 - 2 ZONE DI COTTURA**  
**EN** Electric Fry-top 1/2 grooved + 1/2 smooth, plate cm.76x68 - 2 cooking areas • **DE** Griddleplatte elektrische 1/2 gerillt + 1/2 glatt, platte cm.76x68 - 2 Heizzonen • **FR** Plaque électriques 1/2 nervurée + 1/2 lisse, plaque cm.76x68 - 2 zones de cuisson • **ES** Fry-top eléctrico 1/2 estriado + 1/2 liso, plancha cm.76x68 - 2 zonas de cocción  
**cm. 80x 80x 22h**



⚡ 15 kW \_\_\_\_\_ **2.879,00**  
400V~3N \_\_\_\_\_ 90 / 0,44  
50/60 Hz \_\_\_\_\_



**FTLRD-88ETS**  
28060835

**FRY-TOP ELETTRICO 1/2 RIGATO + 1/2 LISCIO CROMATO SUPERCHROME (MOCA APPROVED), PIASTRA CM.76X68 - 2 ZONE DI COTTURA**  
**EN** Electric Fry-top 1/2 grooved + 1/2 smooth chromed griddle SUPERCHROME (Moca Approved), plate cm.76x68 - 2 cooking areas • **DE** Griddleplatte elektrische 1/2 gerillt + 1/2 glatt hartverchromt SUPERCHROME (Moca Approved), platte cm.76x68 - 2 Heizzonen • **FR** Plaque électriques 1/2 nervurée + 1/2 lisse chromée SUPERCHROME (Moca Approved), plaque cm.76x68 - 2 zones de cuisson • **ES** Fry-top eléctrico 1/2 estriado + 1/2 liso cromado SUPERCHROME (Moca Approved), plancha cm.76x68 - 2 zonas de cocción  
**cm. 80x 80x 22h**



⚡ 15 kW \_\_\_\_\_ **3.502,00**  
400V~3N \_\_\_\_\_ 90 / 0,44  
50/60 Hz \_\_\_\_\_



**PCD-64ET**  
26030430

**PIANO COTTURA TRIFASE N. 2 PIASTRE**  
**EN** Boiling unit - N. 2 plates • **DE** Kochplatte - N. 2 Kochplatten • **FR** Rechaud - N. 2 plaques • **ES** Sobre de cocción - N. 2 planchas  
**cm. 40x 60x 5h**



⚡ 5,2 kW \_\_\_\_\_ **576,00**  
400V~2N \_\_\_\_\_ 19 / 0,13  
230V~3 \_\_\_\_\_  
230V~ \_\_\_\_\_  
50/60 Hz \_\_\_\_\_

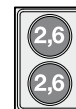

**PCD-68ET**  
26030830

**PIANO COTTURA TRIFASE N. 4 PIASTRE**  
**EN** Boiling unit - N. 4 plates • **DE** Kochplatte - N. 4 Kochplatten • **FR** Rechaud - N. 4 plaques • **ES** Sobre de cocción - N. 4 planchas  
**cm. 80x 60x 5h**

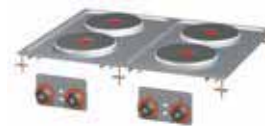

⚡ 10,4 kW \_\_\_\_\_ **889,00**  
400V~3N \_\_\_\_\_ 38 / 0,32  
230V~3 \_\_\_\_\_  
50/60 Hz \_\_\_\_\_





# PIANI COTTURA ELETTRICI 60

MOD. \_\_\_\_\_  
COD. \_\_\_\_\_

DESCRIZIONE/DESCRIPTION/BEZEICHNUNG/DESCRIPTION/DESCRIPCIÓN  
DIMENSIONI/DIMENSIONS/ABMESSUNGEN/DIMENSIONS/DIMENSIONES

POTENZA/POWER/LEISTUNG/PUISSANCE/POTENCIA  
VOLTAGGIO/VOLTAGE/SPANNUNG/VOLTAGE/VOLTAJE

⚡ kW \_\_\_\_\_  
kcal/h \_\_\_\_\_  
V~ \_\_\_\_\_  
Hz \_\_\_\_\_

PREZZO/PRICE € \_\_\_\_\_  
PREIS/PRIX/PRECIO € \_\_\_\_\_  
KG / M<sup>3</sup> \_\_\_\_\_

## PCQD-64ET PIANO COTTURA TRIFASE - N. 2 PIASTRE QUADRE

26030431  
EN Boiling unit threephase - N. 2 square plates • DE Kochplatte dreiphasig - N. 2 quadratischen Platten • FR Rechaud électriques - N. 2 plaques carrés • ES Sobre de cocción trifásico - N. 2 planchas cuadradas  
cm. 40x 60x 5h



⚡ 5,2 kW \_\_\_\_\_ 1.140,00  
400V~2N \_\_\_\_\_ 19 / 0,13  
230V~3  
230V~  
50/60 Hz

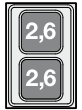

## PCQD-68ET PIANO COTTURA TRIFASE - N. 4 PIASTRE QUADRE

26030831  
EN Boiling unit threephase - N. 4 square plates • DE Kochplatte dreiphasig - N. 4 quadratischen Platten • FR Rechaud électriques - N. 4 plaques carrés • ES Sobre de cocción trifásico - N. 4 planchas cuadradas  
cm. 80x 60x 5h

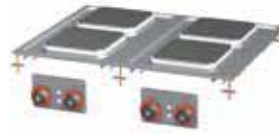

⚡ 10,4 kW \_\_\_\_\_ 1.997,00  
400V~3N \_\_\_\_\_ 38 / 0,32  
230V~3  
50/60 Hz



## PCQD-84ET PIANO COTTURA TRIFASE - N. 2 PIASTRE QUADRE

28030431  
EN Boiling unit threephase - N. 2 square plates • DE Kochplatte dreiphasig - N. 2 quadratischen Platten • FR Rechaud électriques - N. 2 plaques carrés • ES Sobre de cocción trifásico - N. 2 planchas cuadradas  
cm. 40x 80x 5h

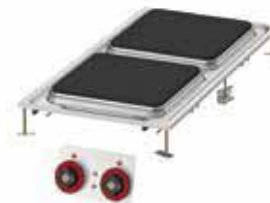

⚡ 8 kW \_\_\_\_\_ 1.598,00  
400V~2N \_\_\_\_\_ 24 / 0,23  
230V~3  
230V~  
50/60 Hz



## PCQD-88ET PIANO COTTURA TRIFASE - N. 4 PIASTRE QUADRE

28030831  
EN Boiling unit threephase - N. 4 square plates • DE Kochplatte dreiphasig - N. 4 quadratischen Platten • FR Rechaud électriques - N. 4 plaques carrés • ES Sobre de cocción trifásico - N. 4 planchas cuadradas  
cm. 80x 80x 5h

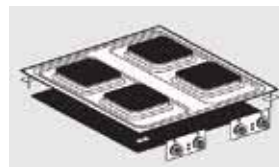

⚡ 16 kW \_\_\_\_\_ 2.952,00  
400V~3N \_\_\_\_\_ 48 / 0,44  
50/60 Hz



## PCCD-64ET PIANO COTTURA VETROCERAMICA TRIFASE - N. 2 ZONE - VETRO CM.35X57

26030432  
EN Ceramic glass boiling unit - n. 2 zones - glass cm.35x57 • DE Ceran-Kochplatte dreiphasig - 2 zonen - Glas 35x57 cm • FR Plan de cuisson à vitroceramique triphasé N. 2 zones - Verre cm.35x57 • ES Sobre de cocción trifásico vitrocerámica - 2 zonas - vidrio cm.35x57  
cm. 40x 60x 5h

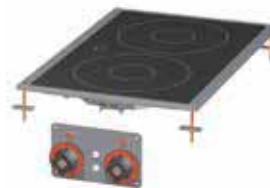

⚡ 5 kW \_\_\_\_\_ 1.212,00  
400V~2N \_\_\_\_\_ 12 / 0,13  
230V~3  
230V~  
50/60 Hz

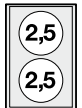

Le immagini presentate non sono vincolanti. La ditta si riserva di apportare modifiche senza preavviso. • The pictures are purely representative. The manufacturer reserves the right to modify the technical data and models without previous notice. • Les images

LO

présentées ne nous engagent pas. La Société se réserve le droit d'apporter tout modification sans préavis. • Die dargestellten Abbildungen sind nicht verbindlich. Technische Änderungen vorbehalten. • Las imágenes presentadas no son vinculantes. El Fabricante se reserva el derecho de modificar sus productos sin previo aviso.

01/20

349

# PIANI COTTURA ELETTRICI 60

MOD. \_\_\_\_\_  
COD. \_\_\_\_\_

DESCRIZIONE/DESCRIPTION/BEZEICHNUNG/DESCRIPTION/DESCRIPCIÓN  
DIMENSIONI/DIMENSIONS/ABMESSUNGEN/DIMENSIONS/DIMENSIONES

POTENZA/POWER/LEISTUNG/PUISSANCE/POTENCIA  
VOLTAGGIO/VOLTAGE/SPANNUNG/VOLTAGE/VOLTAJE

⚡ kW \_\_\_\_\_  
kcal/h \_\_\_\_\_  
V~ \_\_\_\_\_  
Hz \_\_\_\_\_

PREZZO/PRICE € \_\_\_\_\_  
PREIS/PRIX/PRECIO € \_\_\_\_\_  
KG / M<sup>3</sup> \_\_\_\_\_

**PCCD-68ET** **PIANO COTTURA VETROCERAMICA TRIFASE**  
26030832 **- N. 4 ZONE - VETRO CM.75X57**

**EN** Ceramic glass boiling unit - n. 4 zones - glass cm.75x57 • **DE** Ceran-Kochplatte dreiphasig - 4 zonen - Glas 75x57 cm • **FR** Plan de cuisson à vitroceramique triphasé N. 4 zones - Verre cm.75x57 • **ES** Sobre de cocción trifásico vitrocerámica - 4 zonas - vidrio cm.75x57  
**cm. 80x 60x 5h**

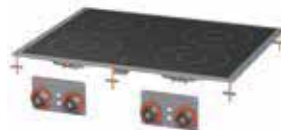

⚡ 10 kW \_\_\_\_\_ **1.808,00**  
400V~3N \_\_\_\_\_ 40 / 0,32  
230V~3 \_\_\_\_\_  
50/60 Hz \_\_\_\_\_

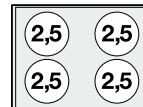

**PCCD-84ET** **PIANO COTTURA VETROCERAMICA TRIFASE**  
28030432 **- N. 2 ZONE - VETRO CM.35X77**

**EN** Ceramic glass boiling unit - n. 2 zones - glass cm.35x77 • **DE** Ceran-Kochplatte dreiphasig - 2 zonen - Glas 35x77 cm • **FR** Plan de cuisson à vitroceramique triphasé N. 2 zones - Verre cm.35x77 • **ES** Sobre de cocción trifásico vitrocerámica - 2 zonas - vidrio cm.35x77  
**cm. 40x 80x 5h**



⚡ 6,8 kW \_\_\_\_\_ **1.983,00**  
400V~2N \_\_\_\_\_ 24 / 0,23  
230V~3 \_\_\_\_\_  
230V~ \_\_\_\_\_  
50/60 Hz \_\_\_\_\_



**PCCD-88ET** **PIANO COTTURA VETROCERAMICA TRIFASE**  
28030832 **- N. 4 ZONE - VETRO CM.75X77**

**EN** Ceramic glass boiling unit - n. 4 zones - glass cm.75x77 • **DE** Ceran-Kochplatte dreiphasig - 4 zonen - Glas 75x77 cm • **FR** Plan de cuisson à vitroceramique triphasé N. 4 zones - Verre cm.75x77 • **ES** Sobre de cocción trifásico vitrocerámica - 4 zonas - vidrio cm.75x77  
**cm. 80x 80x 5h**

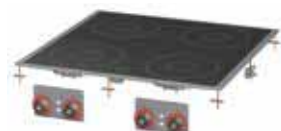

⚡ 13,6 kW \_\_\_\_\_ **3.473,00**  
400V~3N \_\_\_\_\_ 48 / 0,44  
230V~3 \_\_\_\_\_  
50/60 Hz \_\_\_\_\_

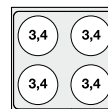

**PCID-44ET** **PIANO COTTURA INDUZIONE TRIFASE**  
24030433 **- N. 1 ZONA - VETRO CM.35X35 (NON POSIZIONARE SU FORNI O CASSETTIERE)**

**EN** Three-phase induction cooking - 1 zone - glass cm.35x35 (do not place on ovens or drawers) • **DE** Induktions-Kochplatte dreiphasig - 1 zone - Glas 35x35 cm (nicht Platz auf Öfen oder Schubladen) • **FR** Plan de cuisson à induction triphasé N. 1 zone - Verre cm.35x35 (ne placez pas sur des fours ou des tiroirs) • **ES** Encimera inducción trifásica - 1 zona - Vidrio cm.35x35 (No coloque en los hornos o en los cajones)  
**cm. 40x 40x 31h**



⚡ 5 kW \_\_\_\_\_ **4.240,00**  
400V~3 \_\_\_\_\_ 18 / 0,17  
50/60 Hz \_\_\_\_\_

**PCID-44ETD** **PIANO COTTURA INDUZIONE TRIFASE**  
24030438 **- N. 1 ZONA - VETRO CM.35X35 (NON POSIZIONARE SU FORNI O CASSETTIERE) - COMANDI DIGITALI**

**EN** Three-phase induction cooking - 1 zone - glass cm.35x35 (do not place on ovens or drawers) - digital controls • **DE** Induktions-Kochplatte dreiphasig - 1 zone - Glas 35x35 cm (nicht Platz auf Öfen oder Schubladen) - digitale Steuerungen • **FR** Plan de cuisson à induction triphasé N. 1 zone - Verre cm.35x35 (ne placez pas sur des fours ou des tiroirs) - commandes numériques • **ES** Encimera inducción trifásica - 1 zona - Vidrio cm.35x35 (No coloque en los hornos o en los cajones) - controles digitales  
**cm. 40x 40x 31h**

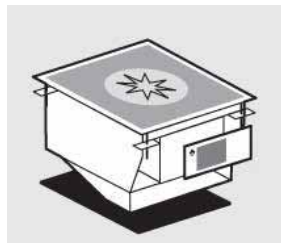

⚡ 5 kW \_\_\_\_\_ **4.481,00**  
400V~3 \_\_\_\_\_ 18 / 0,17  
50/60 Hz \_\_\_\_\_

# PIANI COTTURA A INDUZIONE 60

MOD. \_\_\_\_\_  
COD. \_\_\_\_\_

DESCRIZIONE/DESCRIPTION/BEZEICHNUNG/DESCRIPTION/DESCRIPCIÓN  
DIMENSIONI/DIMENSIONS/ABMESSUNGEN/DIMENSIONS/DIMENSIONES

POTENZA/POWER/LEISTUNG/PUISSANCE/POTENCIA  
VOLTAGGIO/VOLTAGE/SPANNUNG/VOLTAGE/VOLTAJE

⚡ kW kcal/h  
400V~3  
50/60 Hz

PREZZO/PRICE €  
PREIS/PRIX/PRECIO €  
KG / M<sup>3</sup>

**PCID-64ET**  
26030433

**PIANO COTTURA INDUZIONE TRIFASE**  
**- N. 2 ZONE - VETRO CM.35X57 (NON**  
**POSIZIONARE SU FORNI O CASSETTIERE)**  
**EN** Three-phase induction cooking - 2 zones - glass  
cm.35x57 (do not place on ovens or drawers) • **DE**  
Induktions-Kochplatte dreiphasig - 2 zonen - Glas  
35x57 cm (nicht Platz auf Öfen oder Schubladen) • **FR**  
Plan de cuisson à induction triphasé N. 2 zones - Verre  
cm.35x57 (ne placez pas sur des fours ou des tiroirs)  
• **ES** Encimera inducción trifásica - 2 zonas - Vidrio  
cm.35x57 (No coloque en los hornos o en los cajones)  
**cm. 40x 60x 31h**



⚡ 10 kW **6.596,00**  
400V~3 20 / 0,17  
50/60 Hz

**PCID-64ETD**  
26030438

**PIANO COTTURA INDUZIONE TRIFASE**  
**- N. 2 ZONE - VETRO CM.35X57 (NON**  
**POSIZIONARE SU FORNI O CASSETTIERE) -**  
**COMANDI DIGITALI**  
**EN** Three-phase induction cooking - 2 zones - glass  
cm.35x57 (do not place on ovens or drawers) - digital  
controls • **DE** Induktions-Kochplatte dreiphasig - 2  
zonen - Glas 35x57 cm (nicht Platz auf Öfen oder  
Schubladen) - digitale Steuerungen • **FR** Plan de cuisson  
à induction triphasé N. 2 zones - Verre cm.35x57 (ne  
placez pas sur des fours ou des tiroirs) - commandes  
numériques • **ES** Encimera inducción trifásica - 2 zonas  
- Vidrio cm.35x57 (No coloque en los hornos o en los  
cajones) - controles digitales  
**cm. 40x 60x 31h**

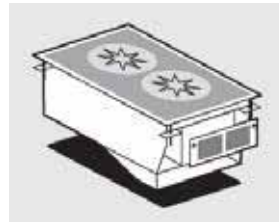

⚡ 10 kW **7.079,00**  
400V~3 20 / 0,17  
50/60 Hz

**PCID-84ET**  
28030433

**PIANO COTTURA INDUZIONE TRIFASE**  
**- N. 2 ZONE - VETRO CM.35X77 (NON**  
**POSIZIONARE SU FORNI O CASSETTIERE)**  
**EN** Three-phase induction cooking - 2 zones - glass  
cm.35x77 (do not place on ovens or drawers) • **DE**  
Induktions-Kochplatte dreiphasig - 2 zonen - Glas  
35x77 cm (nicht Platz auf Öfen oder Schubladen) • **FR**  
Plan de cuisson à induction triphasé N. 2 zones - Verre  
cm.35x77 (ne placez pas sur des fours ou des tiroirs)  
• **ES** Encimera inducción trifásica - 2 zonas - Vidrio  
cm.35x77 (No coloque en los hornos o en los cajones)  
**cm. 40x 80x 31h**



⚡ 10 kW **6.803,00**  
400V~3 25 / 0,23  
50/60 Hz

**PCID-84ETD**  
28030438

**PIANO COTTURA INDUZIONE TRIFASE**  
**- N. 2 ZONE - VETRO CM.35X77 (NON**  
**POSIZIONARE SU FORNI O CASSETTIERE) -**  
**COMANDI DIGITALI**  
**EN** Three-phase induction cooking - 2 zones - glass  
cm.35x77 (do not place on ovens or drawers) - digital  
controls • **DE** Induktions-Kochplatte dreiphasig - 2  
zonen - Glas 35x77 cm (nicht Platz auf Öfen oder  
Schubladen) - digitale Steuerungen • **FR** Plan de cuisson  
à induction triphasé N. 2 zones - Verre cm.35x77 (ne  
placez pas sur des fours ou des tiroirs) - commandes  
numériques • **ES** Encimera inducción trifásica - 2 zonas  
- Vidrio cm.35x77 (No coloque en los hornos o en los  
cajones) - controles digitales  
**cm. 40x 80x 31h**

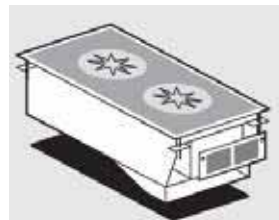

⚡ 10 kW **7.286,00**  
400V~3 25 / 0,23  
50/60 Hz

**PCID-68ET**  
26030833

**PIANO COTTURA INDUZIONE TRIFASE**  
**- N. 4 ZONE - VETRO CM.75X57 (NON**  
**POSIZIONARE SU FORNI O CASSETTIERE)**  
**EN** Three-phase induction cooking - 4 zones - glass  
cm.75x57 (do not place on ovens or drawers) • **DE**  
Induktions-Kochplatte dreiphasig - 4 zonen - Glas  
75x57 cm (nicht Platz auf Öfen oder Schubladen) • **FR**  
Plan de cuisson à induction triphasé N. 4 zones - Verre  
cm.75x57 (ne placez pas sur des fours ou des tiroirs)  
• **ES** Encimera inducción trifásica - 4 zonas - Vidrio  
cm.75x57 (No coloque en los hornos o en los cajones)  
**cm. 80x 60x 31h**



⚡ 20 kW **12.353,00**  
400V~3 40 / 0,32  
50/60 Hz



Le immagini presentate non sono vincolanti. La ditta si riserva di apportare modifiche senza preavviso. • The pictures are purely representative. The manufacturer reserves the right to modify the technical data and models without previous notice. • Les images

LO

présentées ne nous engagent pas. La Société se réserve le droit d'apporter tout modification sans préavis. • Die dargestellten Abbildungen sind nicht verbindlich. Technische Änderungen vorbehalten. • Las imágenes presentadas no son vinculantes. El Fabricante se reserva el derecho de modificar sus productos sin previo aviso.

01/20

351

# PIANI COTTURA A INDUZIONE 60

MOD. \_\_\_\_\_  
COD. \_\_\_\_\_

DESCRIZIONE/DESCRIPTION/BEZEICHNUNG/DESCRIPTION/DESCRIPCIÓN  
DIMENSIONI/DIMENSIONS/ABMESSUNGEN/DIMENSIONS/DIMENSIONES

POTENZA/POWER/LEISTUNG/PUISSANCE/POTENCIA  
VOLTAGGIO/VOLTAGE/SPANNUNG/VOLTAGE/VOLTAJE

⚡ kW \_\_\_\_\_ kcal/h \_\_\_\_\_  
400V~3 \_\_\_\_\_ V~ \_\_\_\_\_  
50/60 Hz \_\_\_\_\_ Hz

PREZZO/PRICE € \_\_\_\_\_  
PREIS/PRIX/PRECIO € \_\_\_\_\_  
KG / M<sup>3</sup> \_\_\_\_\_

**PCID-68ETD** **PIANO COTTURA INDUZIONE TRIFASE**  
26030838 - **N. 4 ZONE - VETRO CM.75X57 (NON**  
**POSIZIONARE SU FORNI O CASSETTIERE) -**  
**COMANDI DIGITALI**

**EN** Three-phase induction cooking - 4 zones - glass cm.75x57 (do not place on ovens or drawers) - digital controls • **DE** Induktions-Kochplatte dreiphasig - 4 zonen - Glas 75x57 cm (nicht Platz auf Öfen oder Schubladen) - digitale Steuerungen • **FR** Plan de cuisson à induction triphasé N. 4 zones - Verre cm.75x57 (ne placez pas sur des fours ou des tiroirs) - commandes numériques • **ES** Encimera inducción trifásica - 4 zonas - Vidrio cm.75x57 (No coloque en los hornos o en los cajones) - controles digitales  
**cm. 80x 60x 31h**



⚡ 20 kW \_\_\_\_\_ **13.319,00**  
400V~3 \_\_\_\_\_ 40 / 0,32  
50/60 Hz \_\_\_\_\_

**PCID-88ET** **PIANO COTTURA INDUZIONE TRIFASE**  
28030833 - **N. 4 ZONE - VETRO CM.75X77 (NON**  
**POSIZIONARE SU FORNI O CASSETTIERE)**

**EN** Three-phase induction cooking - 4 zones - glass cm.75x77 (do not place on ovens or drawers) • **DE** Induktions-Kochplatte dreiphasig - 4 zonen - Glas 75x77 cm (nicht Platz auf Öfen oder Schubladen) • **FR** Plan de cuisson à induction triphasé N. 4 zones - Verre cm.75x77 (ne placez pas sur des fours ou des tiroirs) • **ES** Encimera inducción trifásica - 4 zonas - Vidrio cm.75x77 (No coloque en los hornos o en los cajones)  
**cm. 80x 80x 31h**



⚡ 20 kW \_\_\_\_\_ **13.060,00**  
400V~3 \_\_\_\_\_ 50 / 0,44  
50/60 Hz \_\_\_\_\_

**PCID-88ETD** **PIANO COTTURA INDUZIONE TRIFASE**  
28030838 - **N. 4 ZONE - VETRO CM.75X77 (NON**  
**POSIZIONARE SU FORNI O CASSETTIERE) -**  
**COMANDI DIGITALI**

**EN** Three-phase induction cooking - 4 zones - glass cm.75x77 (do not place on ovens or drawers) - digital controls • **DE** Induktions-Kochplatte dreiphasig - 4 zonen - Glas 75x77 cm (nicht Platz auf Öfen oder Schubladen) - digitale Steuerungen • **FR** Plan de cuisson à induction triphasé N. 4 zones - Verre cm.75x77 (ne placez pas sur des fours ou des tiroirs) - commandes numériques • **ES** Encimera inducción trifásica - 4 zonas - Vidrio cm.75x77 (No coloque en los hornos o en los cajones) - controles digitales  
**cm. 80x 80x 31h**



⚡ 20 kW \_\_\_\_\_ **14.026,00**  
400V~3 \_\_\_\_\_ 50 / 0,44  
50/60 Hz \_\_\_\_\_

**PCIWD-64ET** **PIANO COTTURA INDUZIONE TRIFASE "WOK"**  
26030434 - **N. 1 ZONA - VETRO Ø 30 CM. (NON**  
**POSIZIONARE SU FORNI O CASSETTIERE)**

**EN** Three-phase induction cooking "WOK" - 1 zone - glass Ø 30 cm (do not place on ovens or drawers) • **DE** Induktions-Kochplatte "WOK" dreiphasig - 1 zonen - Glas Ø 30 cm (nicht Platz auf Öfen oder Schubladen) • **FR** Plan de cuisson à induction "WOK" triphasé N. 1 zone - Verre cm Ø 30 (ne placez pas sur des fours ou des tiroirs) • **ES** Encimera inducción "WOK" trifásica - 1 zona - Vidrio Ø 30 cm (No coloque en los hornos o en los cajones)  
**cm. 40x 60x 31h**

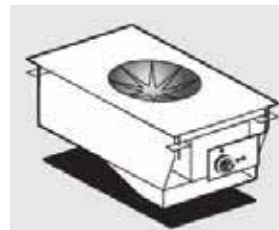

⚡ 5 kW \_\_\_\_\_ **4.960,00**  
400V~3 \_\_\_\_\_ 20 / 0,17  
50/60 Hz \_\_\_\_\_



# PIANI COTTURA A INDUZIONE 60

MOD. \_\_\_\_\_  
COD. \_\_\_\_\_

DESCRIZIONE/DESCRIPTION/BEZEICHNUNG/DESCRIPTION/DESCRIPCIÓN  
DIMENSIONI/DIMENSIONS/ABMESSUNGEN/DIMENSIONS/DIMENSIONES

POTENZA/POWER/LEISTUNG/PUISSANCE/POTENCIA  
VOLTAGGIO/VOLTAGE/SPANNUNG/VOLTAGE/VOLTAJE

⚡ kW \_\_\_\_\_  
400V~3  
50/60 Hz

PREZZO/PRICE €  
PREIS/PRIX/PRECIO €  
KG / M<sup>3</sup>

## PC1WD-64ETD PIANO COTTURA INDUZIONE TRIFASE "WOK"

26030439

- N. 1 ZONA - VETRO Ø 30 CM. (NON POSIZIONARE SU FORNI O CASSETTIERE) - COMANDI DIGITALI

EN Three-phase induction cooking "WOK" - 1 zone - glass Ø 30 cm (do not place on ovens or drawers) - digital controls • DE Induktions-Kochplatte "WOK" dreiphasig - 1 zonen - Glas Ø 30 cm (nicht Platz auf Öfen oder Schubladen) - digitale Steuerungen • FR Plan de cuisson à induction "WOK" triphasé N. 1 zone - Verre cm Ø 30 (ne placez pas sur des fours ou des tiroirs) - commandes numériques • ES Encimera inducción "WOK" trifásica - 1 zona - Vidrio Ø 30 cm (No coloque en los hornos o en los cajones) - controles digitales

cm. 40x 60x 31h



⚡ 5 kW \_\_\_\_\_ **5.201,00**  
400V~3  
50/60 Hz 20 / 0,17

## TPD-68ET TUTTA PIASTRA PIASTRA CM. 70X50 - 4 ZONE

26120830

EN Solid top - Plate cm. 70x50 - 4 zones • DE Kochplatten - Platte cm. 70x50 - 4 zonen • FR Toute plaque - Plaque cm. 70x50 - 4 zones • ES Placa de cocción - Placa cm. 70x50 - 4 zonas

cm. 80x 60x 24h



⚡ 10 kW \_\_\_\_\_ **2.591,00**  
400V~3N  
50/60 Hz 80 / 0,32

## TPD-88ET TUTTA PIASTRA PIASTRA CM. 70X68 - 4 ZONE

28120830

EN Solid top - Plate cm. 70x68 - 4 zones • DE Kochplatten - Platte cm. 70x68 - 4 zonen • FR Toute plaque - Plaque cm. 70x68 - 4 zones • ES Placa de cocción - Placa cm. 70x68 - 4 zonas

cm. 80x 80x 24h



⚡ 13,6 kW \_\_\_\_\_ **3.231,00**  
400V~3N  
50/60 Hz 93 / 0,44

## FSD-78ET FORNO ELETTRICO STATICO CM. 67X55X34H, TEMP: 50÷300°C, CON 1 GRIGLIA CM.65X53 GN2/1

26500830

EN Traditional electric oven cm. 67x55x34h, temp: 50÷300°C, with 1 grid cm.65x53 GN2/1 • DE Statischer Elektro-Backofen cm. 67x55x34h, temp: 50÷300°C, mit 1 Rost cm.65x53 GN2/1 • FR Four électrique statique cm. 67x55x34h, temp: 50÷300°C, avec 1 grille cm.65x53 GN2/1 • ES Horno eléctrico estático cm. 67x55x34h, temp: 50÷300°C, con 1 parilla cm.65x53 GN2/1

cm. 80x 69x 48,6h



⚡ 5 kW \_\_\_\_\_ **1.409,00**  
400V~3N  
50/60 Hz 40 / 0,49

## FVD-78ET FORNO ELETTRICO VENTILATO CM. 55X36X34H, TEMP: 50÷300°C, CON 1 GRIGLIA CM.53X32,5 GN1/1

26500835

EN Electric fan oven cm. 55x36x34h, temp: 50÷300°C, with 1 grid cm.53x32,5 GN1/1 • DE Elektro-Heißluftofen cm. 55x36x34h, temp: 50÷300°C, mit 1 Rost cm.53x32,5 GN1/1 • FR Four à chaleur tournante électrique cm. 55x36x34h, temp: 50÷300°C, avec 1 grille cm.53x32,5 GN1/1 • ES Horno eléctrico ventilado cm. 55x36x34h, temp: 50÷300°C, con 1 parilla cm.53x32,5 GN1/1

cm. 80x 61,5x 48,6h



⚡ 5,32 kW \_\_\_\_\_ **1.735,00**  
400V~3N  
230V~3  
50/60 Hz 40 / 0,49

## FSD-98ET FORNO ELETTRICO STATICO CM. 67X73X34H, TEMP: 50÷300°C, CON 1 GRIGLIA CM.65X71 GN2/1

28500830

EN Traditional electric oven cm. 67x73x34h, temp: 50÷300°C, with 1 grid cm.65x71 GN2/1 • DE Statischer Elektro-Backofen cm. 67x73x34h, temp: 50÷300°C, mit 1 Rost cm.65x71 GN2/1 • FR Four électrique statique cm. 67x73x34h, temp: 50÷300°C, avec 1 grille cm.65x71 GN2/1 • ES Horno eléctrico estático cm. 67x73x34h, temp: 50÷300°C, con 1 parilla cm.65x71 GN2/1

cm. 80x 85,5x 48,6h



⚡ 6,7 kW \_\_\_\_\_ **1.483,00**  
400V~3N  
50/60 Hz 45 / 0,62



Le immagini presentate non sono vincolanti. La ditta si riserva di apportare modifiche senza preavviso. • The pictures are purely representative. The manufacturer reserves the right to modify the technical data and models without previous notice. • Les images

LO

présentées ne nous engagent pas. La Société se réserve le droit d'apporter tout modification sans préavis. • Die dargestellten Abbildungen sind nicht verbindlich. Technische Änderungen vorbehalten. • Las imágenes presentadas no son vinculantes. El Fabricante se reserva el derecho de modificar sus productos sin previo aviso.

01/20

353



# FORNO MANTENITORE

MOD. \_\_\_\_\_  
COD. \_\_\_\_\_

DESCRIZIONE/DESCRIPTION/BEZEICHNUNG/DESCRIPTION/DESCRIPCIÓN  
DIMENSIONI/DIMENSIONS/ABMESSUNGEN/DIMENSIONS/DIMENSIONES

POTENZA/POWER/LEISTUNG/PUISSANCE/POTENCIA  
VOLTAGGIO/VOLTAGE/SPANNUNG/VOLTAGE/VOLTAJE

⚡ kW \_\_\_\_\_  
230V~  
kcal/h \_\_\_\_\_  
V~  
Hz \_\_\_\_\_

PREZZO/PRICE €  
PREIS/PRIX/PRECIO €  
KG / M<sup>3</sup>

CSD012E  
\_CSD012E

**FORNO PER COTTURA A BASSE TEMPERATURE A 2 CASSETTI GN1/1 MAX CM.15H. TEMP: 30÷120°C. PANNELLO DI CONTROLLO CON REGOLAZIONE ELETTRONICA DEL TEMPO, DELLA TEMPERATURA E DELLA SONDA AL CUORE, FUNZIONE MANTENIMENTO. VERSIONE INCASSO PER FREEBLOCK 5\_0 EN** Low temperature oven with 2 drawers GN1/1 max. cm.15h, temp: 30÷120°C. Electronic control of the time, temperature and core probe, HOLD function. DROPIN VERSION FOR FREEBLOCK 5\_0. • **DE** Niedertemperaturofen mit 2 Schubladen GN1/1 max. cm. 15h, temp: 30÷120°C. Bedienfeld mit elektronischer Einstellung für Zeit, Temperatur, heißer Wartungsfunktion. DROPIN VERSION FÜR FREEBLOCK 5\_0. • **FR** Four basse température avec 2 tiroirs GN1/1 max. cm. 15h, temp: 30÷120°C. Contrôle électronique du temps, température et sonde à coeur, fonction de maintenance à chaud. DROPIN VERSION POUR FREEBLOCK 5\_0. • **ES** Horno de baja temperatura con 2 cajones GN1/1 max. cm.15h, temp: 30÷120°C. Panel de control con regulación electrónica de tiempo, temperatura y sonda al corazón, función de mantenimiento caliente. VERSION DE ENCASTRE PARA FREEBLOCK 5\_0.  
**cm. 80x 61x 51h**



⚡ 1 kW \_\_\_\_\_ **3.750,00**  
230V~ \_\_\_\_\_ 55 /  
50 Hz \_\_\_\_\_

PCD-44G  
24210450

**PIANO COTTURA 1 FUOCO EN** Boiling unit - 1 burner • **DE** kochplatte - 1 Kochstellen • **FR** Rechaud - 1 feux vifs • **ES** Sobre de cocción - 1 quemador  
**cm. 40x 40x 14h**



⚡ 10 kW \_\_\_\_\_ **918,00**  
8.600 kcal/h \_\_\_\_\_ 23 / 0,17

PCD-55G  
25210550

**PIANO COTTURA 1 FUOCO, CON GRIGLIA RIBASSATA PER ALLINEAMENTO AI MODELLI GAS TPD/FTD EN** Boiling unit - 1 burner, with lowered grid for alignment to gas models TPD/FTD • **DE** kochplatte - 1 Kochstellen, mit abgesenktem Gitter zur Ausrichtung mit den Gasmodellen TPD/FTD • **FR** Rechaud - 1 feux vifs, avec grille abaissée pour l'alignement sur les modèles à gaz TPD/FTD • **ES** Sobre de cocción - 1 quemador, con rejilla rebajada para su alineación con los modelos de gas TPD/FTD  
**cm. 50x 50x 22h**



⚡ 10 kW \_\_\_\_\_ **970,00**  
8.600 kcal/h \_\_\_\_\_ 24 / 0,27

PCD-64G  
26210450

**PIANO COTTURA 2 FUOCHI EN** Gas heated boiling - 2 burners • **DE** Gas-Kochplatte - 2 Kochstellen • **FR** Rechaud gaz - 2 feux vifs • **ES** Sobres de cocción gas - 2 quemadores  
**cm. 40x 60x 11h**



⚡ 13 kW \_\_\_\_\_ **1.051,00**  
11.180 kcal/h \_\_\_\_\_ 20 / 0,17

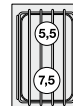

PCD-68G  
26210850

**PIANO COTTURA 4 FUOCHI EN** Gas heated boiling unit - 4 burners • **DE** Gas-Kochplatte - 4 Kochstellen • **FR** Rechaud gaz - 4 feux vifs • **ES** Sobres de cocción gas - 4 quemadores  
**cm. 80x 60x 11h**

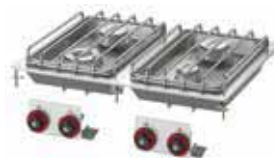

⚡ 22 kW \_\_\_\_\_ **1.978,00**  
18.920 kcal/h \_\_\_\_\_ 40 / 0,35

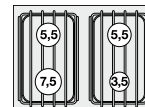

# PIANI COTTURA A GAS 80

MOD. \_\_\_\_\_  
COD. \_\_\_\_\_

DESCRIZIONE/DESCRIPTION/BEZEICHNUNG/DESCRIPTION/DESCRIPCIÓN  
DIMENSIONI/DIMENSIONS/ABMESSUNGEN/DIMENSIONS/DIMENSIONES

POTENZA/POWER/LEISTUNG/PUISSANCE/POTENCIA  
VOLTAGGIO/VOLTAGE/SPANNUNG/VOLTAGE/VOLTAJE

⚡ kW  
kcal/h

⚡ kW  
V~  
Hz

PREZZO/PRICE €  
PREIS/PRIX/PRECIO €  
KG / M<sup>3</sup>

**PCD-84G**  
28210450

## PIANO COTTURA 2 FUOCHI

**EN** Gas heated boiling - 2 burners • **DE** Gas-Kochplatte - 2 Kochstellen • **FR** Rechaud gaz - 2 feux vifs • **ES** Sobres de cocción gas - 2 quemadores  
**cm. 40x 80x 11h**



⚡ 11 kW  
9.460 kcal/h

**1.383,00**  
55 / 0,23



**PCD-88G**  
28210850

## PIANO COTTURA 4 FUOCHI

**EN** Gas heated boiling unit - 4 burners • **DE** Gas-Kochplatte - 4 Kochstellen • **FR** Rechaud gaz - 4 feux vifs • **ES** Sobres de cocción gas - 4 quemadores  
**cm. 80x 80x 11h**



⚡ 28 kW  
24.080 kcal/h

**2.422,00**  
75 / 0,44

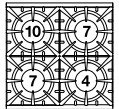

**PCAD-84G**  
28310450

## PIANO COTTURA ACQUA 2 FUOCHI - RUBINETTO CARICO ACQUA, SFIORATORE

**EN** water heated boiling unit 2 burners - Water loading tap + overflow device • **DE** wasser-Kochplatte - 2 Kochstellen - Wasserlauf-Hahn + Überlauf-Vorrichtung • **FR** Rechaud l'eau 2 feux vifs - Robinet d'arrivée d'eau trop plein • **ES** Sobres de cocción agua 2 quemadores - Grifo carga agua + vertedero  
**cm. 40x 80x 12h**



⚡ 14 kW  
12.040 kcal/h

**1.765,00**  
55 / 0,23

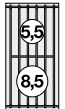

**PCAD-88G**  
28310850

## PIANO COTTURA ACQUA 4 FUOCHI - RUBINETTO CARICO ACQUA, SFIORATORE

**EN** water heated boiling unit 4 burners - Water loading tap + overflow device • **DE** wasser-kochplatte - 4 Kochstellen - Wasserlauf-Hahn + Überlauf-Vorrichtung • **FR** Rechaud l'eau 4 feux vifs - Robinet d'arrivée d'eau trop plein • **ES** Sobres de cocción agua 4 quemadores - Grifo carga agua + vertedero  
**cm. 80x 80x 12h**

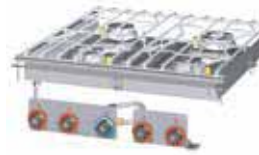

⚡ 28 kW  
24.080 kcal/h

**2.917,00**  
75 / 0,44



**CPD-74G**  
27270450

## CUOCIPASTA GAS LT 25 VASCA CM. 30,5X33,5X32,7H. RUBINETTO CARICO ACQUA, SFIORATORE + SCARICO A PAVIMENTO. ACCENSIONE ELETTRICA, INDICATORE PRESENZA FIAMMA PILOTA. (CESTI ESCLUSI)

**EN** Gas pasta cooker 25 lts. Tank cm. 30,5x33,5x32,7h. Water loading cock + overflow device and floor draining. Electric ignition, flame presence indicator. (BASKETS EXCLUDED) • **DE** Gas-Nudelkocher lt. 25. Becken cm. 30,5x33,5x32,7h. Wasserlauf-Hahn, + Überlauf-Vorrichtung und Ablauf am Boden. Elektrische Zündung, Flammenpräsenzanzeige. (KORB AUSGESCHLOSSEN) • **FR** Cuiseur à pâtes gaz lt. 25. Cuve cm.30,5x33,5x32,7h. Robinet d'arrivée d'eau trop plein + système de vidange au sol. Allumage électrique, indicateur de présence de flamme. (PANIERS EXCLUS) • **ES** Cuece pasta gas 25 lt. Cuba cm. 30,5x33,5x32,7h. Grifo carga agua + vertedero + descarga a pavimento. Ignición eléctrica, indicador externo de llama piloto. (CESTAS EXCLUIDAS)  
**cm. 40x 70x 65h**



⚡ 9,5 kW  
8.160 kcal/h

**2.327,00**  
51 / 0,37

⚡ 0,02 KW  
230V~  
50/60 Hz

### COMBINAZIONI

- Combinations / • Zusammenstellungen
- Combinaisons / • Combinación múltiple



Le immagini presentate non sono vincolanti. La ditta si riserva di apportare modifiche senza preavviso. • The pictures are purely representative. The manufacturer reserves the right to modify the technical data and models without previous notice. • Les images

LO

présentées ne nous engagent pas. La Société se réserve le droit d'apporter tout modification sans préavis. • Die dargestellten Abbildungen sind nicht verbindlich. Technische Änderungen vorbehalten. • Las imágenes presentadas no son vinculantes. El Fabricante se reserva el derecho de modificar sus productos sin previo aviso.

01/20

**355**

# CUOCIPASTA GAS 70

MOD. \_\_\_\_\_  
COD. \_\_\_\_\_

DESCRIZIONE/DESCRIPTION/BEZEICHNUNG/DESCRIPTION/DESCRIPCIÓN  
DIMENSIONI/DIMENSIONS/ABMESSUNGEN/DIMENSIONS/DIMENSIONES

POTENZA/POWER/LEISTUNG/PUISSANCE/POTENCIA  
VOLTAGGIO/VOLTAGE/SPANNUNG/VOLTAGE/VOLTAJE

⚡ kW kcal/h  
⚡ kW V~ Hz

PREZZO/PRICE €  
PREIS/PRIX/PRECIO €  
KG / M<sup>3</sup>

**CPAD-74G**  
27270455

**CUOCIPASTA GAS LT 25 VASCA CM. 30,5X33,5X32,7H. CARICO ACQUA AUTOMATICO CON SENSORE DI LIVELLO - SFIORATORE + SCARICO A PAVIMENTO. ACCENSIONE ELETTRICA, INDICATORE PRESENZA FIAMMA PILOTA. (CESTI ESCLUSI)**

**EN** Gas pasta cooker 25 lts. Tank cm. 30,5x33,5x32,7h. Automatic Water loading with level sensor - overflow device and floor draining. Electric ignition, flame presence indicator. (BASKETS EXCLUDED) • **DE** Gas-Nudelkocher lt. 25. Becken cm. 30,5x33,5x32,7h. Automatische Wasser Beladung mit Niveauregulierung + Überlauf-Vorrichtung und Ablauf am Boden. Elektrische Zündung, Flammenpräsenzanzeige. (KORB AUSGESCHLOSSEN) • **FR** Cuiseur à pâtes gaz lt. 25. Cuve cm. 30,5x33,5x32,7h. Chargement automatique de l'eau avec sensor de niveau, trop plein Système de vidange au sol. Allumage électrique, indicateur de présence de flamme. (PANIERS EXCLUS) • **ES** Cuece pasta gas 25 lt. Cuba cm. 30,5x33,5x32,7h. Carga automática de agua con sensor de nivel + vertedero + descarga a pavimento. Ignición eléctrica, indicador externo de llama piloto. (CESTAS EXCLUIDAS)  
**cm. 40x 70x 65h**



⚡ 9,5 kW 2.537,00  
8.160 kcal/h 51 / 0,37

⚡ 0,035 kW  
230V~  
50/60 Hz

## COMBINAZIONI

- Combinations / • Zusammenstellungen
- Combinaisons / • Combinación múltiple



**CPD-94G**  
29270450

**CUOCIPASTA GAS LT. 40 VASCA CM. 30,7X50,9X32,7H. RUBINETTO CARICO ACQUA, SFIORATORE + SCARICO A PAVIMENTO. ACCENSIONE ELETTRICA, INDICATORE PRESENZA FIAMMA PILOTA. (CESTI ESCLUSI)**

**EN** Gas pasta cooker 40 lts. - Tank cm. 30,7x50,9x32,7h. Water loading tap + overflow device and floor draining. Electric ignition, flame presence indicator. (BASKETS EXCLUDED) • **DE** Gas-Nudelkocher lt. 40 - Becken cm. 30,7x50,9x32,7h. Wasserlauf-Hahn + Überlauf-Vorrichtung und Ablauf am Boden. Elektrische Zündung, Flammenpräsenzanzeige. (KORB AUSGESCHLOSSEN) • **FR** Cuiseur a pâtes gaz lt. 40 - Cuve cm. 30,7x50,9x32,7h. Robinet d'arrivée d'eau trop plein Système de vidange au sol. Allumage électrique, indicateur de présence de flamme. (PANIERS EXCLUS) • **ES** Cuece pasta gas 40 lt. - Cuba cm. 30,7x50,9x32,7h. Grifo carga agua + vertedero + descarga a pavimento. Ignición eléctrica, indicador externo de llama piloto. (CESTAS EXCLUIDAS)  
**cm. 40x 90x 65h**



⚡ 13,95 kW 2.489,00  
11.997 kcal/h 58 / 0,46

⚡ 0,02 kW  
230V~  
50/60 Hz

## COMBINAZIONI

- Combinations / • Zusammenstellungen
- Combinaisons / • Combinación múltiple



# CUOCIPASTA GAS 90

MOD. \_\_\_\_\_  
COD. \_\_\_\_\_

DESCRIZIONE/DESCRIPTION/BEZEICHNUNG/DESCRIPTION/DESCRIPCIÓN  
DIMENSIONI/DIMENSIONS/ABMESSUNGEN/DIMENSIONS/DIMENSIONES

POTENZA/POWER/LEISTUNG/PUISSANCE/POTENCIA  
VOLTAGGIO/VOLTAGE/SPANNUNG/VOLTAGE/VOLTAJE

⚡ kW kcal/h  
⚡ kW V~ Hz

PREZZO/PRICE €  
PREIS/PRIX/PRECIO €  
KG / M<sup>3</sup>

**CPAD-94G**  
29270455

**CUOCIPASTA GAS LT. 40 VASCA CM. 30,7X50,9X32,7H. CARICO ACQUA AUTOMATICO CON SENSORE DI LIVELLO - SFIORATORE + SCARICO A PAVIMENTO. ACCENSIONE ELETTRICA, INDICATORE PRESENZA FIAMMA PILOTA. (CESTI ESCLUSI)**

**EN** Gas pasta cooker 40 lts. - Tank cm. 30,7x50,9x32,7h. Automatic Water loading with level sensor - overflow device and floor draining. Electric ignition, flame presence indicator. (BASKETS EXCLUDED) • **DE** Gas-Nudelkocher lt. 40 - Becken cm. 30,7x50,9x32,7h. Automatische Wasser Beladung mit Niveauregulierung + Überlauf-Vorrichtung und Ablauf am Boden. Elektrische Zündung, Flammenpräsenzanzeige. (KORB AUSGESCHLOSSEN) • **FR** Cuiseur a pates gaz lt. 40 - Cuve cm.30,7x50,9x32,7h. Chargement automatique de l'eau avec sensor de niveau, trop plein Système de vidange au sol. Allumage électrique, indicateur de présence de flamme. (PANIERS EXCLUS) • **ES** Cuece pasta gas 40 lt. - Cuba cm. 30,7x50,9x32,7h. Carga automática de agua con sensor de nivel + vertedero + descarga a pavimento. Ignición eléctrica, indicador externo de llama piloto. (CESTAS EXCLUIDAS)  
**cm. 40x 90x 65h**



⚡ 13,95 kW 2.699,00  
11.997 kcal/h 58 / 0,46

⚡ 0,035 KW  
230V~  
50/60 Hz

## COMBINAZIONI

- Combinations / • Zusammenstellungen
- Combinaisons / • Combinación múltiple

1/1	1/2	1/3	1/3	1/6 1/6	1/6 1/6
	1/2	1/3	2/3	1/3	1/6 1/6
		1/3		1/3	1/6 1/6

**CWD-75G**  
27250550

**GRIGLIA GAS-PIETRALAVICA, GRIGLIA IN ACCIAIO INOX CM. 38X52 REGOLABILE. ACCENSIONE ELETTRICA, INDICATORE PRESENZA FIAMMA PILOTA, CANALA PERIMETRALE ALLAGABILE, SCARICO CON FILTRO REMOVIBILE.**

**EN** Charcoal grill gas, Stainless steel grill cm. 38x52. Electric ignition, flame presence indicator, floodable perimeter channel, drain with removable filter. • **DE** Gas-Lavasteingrill, Einstellbarer Rost aus Nirosta cm. 38x52. Elektrische Zündung, Flammenpräsenzanzeige, flutbaren Umfangskanal, Auspuff mit abnehmbarem Filter. • **FR** Grille à gaz en pierre de lave, Grille inox cm 38x52. Allumage électrique, indicateur de présence de flamme, un conduit extérieur inondable, échappement avec filtre amovible. • **ES** Parrilla a gas piedra lávica, Parrilla de acero inox regulable cm 38x52. Ignición eléctrica, indicador externo de llama piloto, canal perimetral inundable, drenaje con filtro extraíble.  
**cm. 50x 70x 33h**



⚡ 9 kW 1.804,00  
7.740 kcal/h 51 / 0,26

⚡ 0,001 KW  
230V~  
50/60 Hz



Le immagini presentate non sono vincolanti. La ditta si riserva di apportare modifiche senza preavviso. • The pictures are purely representative. The manufacturer reserves the right to modify the technical data and models without previous notice. • Les images

LO

présentées ne nous engagent pas. La Société se réserve le droit d'apporter tout modification sans préavis. • Die dargestellten Abbildungen sind nicht verbindlich. Technische Änderungen vorbehalten. • Las imágenes presentadas no son vinculantes. El Fabricante se reserva el derecho de modifi car sus productos sin previo aviso.

01/20

357

# GRIGLIE PIETRA LAVICA A GAS 70

MOD. \_\_\_\_\_  
COD. \_\_\_\_\_

DESCRIZIONE/DESCRIPTION/BEZEICHNUNG/DESCRIPTION/DESCRIPCIÓN  
DIMENSIONI/DIMENSIONS/ABMESSUNGEN/DIMENSIONS/DIMENSIONES

POTENZA/POWER/LEISTUNG/PUISSANCE/POTENCIA  
VOLTAGGIO/VOLTAGE/SPANNUNG/VOLTAGE/VOLTAJE

⚡ kW kcal/h  
⚡ kW V~ Hz

PREZZO/PRICE €  
PREIS/PRIX/PRECIO €  
KG / M<sup>3</sup>

**CWD-79G**  
27250950

**GRIGLIA GAS-PIETRALAVICA, N. 2 GRIGLIE IN ACCIAIO INOX CM. 38X52 REGOLABILI, 2 ZONE DI COTTURA. ACCENSIONE ELETTRICA, INDICATORE PRESENZA FIAMMA PILOTA, CANALA PERIMETRALE ALLAGABILE, SCARICO CON FILTRO REMOVIBILE.**

**EN** Charcoal grill gas, N. 2 Stainless steel grill cm. 38x52. 2 cooking areas. Electric ignition, flame presence indicator, floodable perimeter channel, drain with removable filter. • **DE** Gas-Lavasteingrill, N. 2 einstellbare Roste aus Nirosta cm. 38x52 - 2 Heizzonen. Elektrische Zündung, Flammenpräsenzanzeige, flutbaren Umfangskanal, Auspuff mit abnehmbarem Filter. • **FR** Grille a gaz en pierre de lave, N. 2 grilles réglables en acier inox cm. 38x52. 2 zones de cuisson. Allumage électrique, indicateur de présence de flamme, un conduit extérieur inondable, échappement avec filtre amovible. • **ES** Parrilla a gas piedra lávica, N. 2 Parrillas de acero inox regulable cm 38x52 2 zonas de cocción. Ignición eléctrica, indicador externo de llama piloto, canal perimetral inundable, drenaje con filtro extraíble.  
**cm. 90x 70x 33h**



⚡ 18 kW 2.664,00  
15.480 kcal/h 94 / 0,44

⚡ 0,001 KW  
230V~  
50/60 Hz

**TPD-85G**  
28290550

**TUTTA PIASTRA GAS PIASTRA CM 37X57. ACCENSIONE ELETTRICA, INDICATORE PRESENZA FIAMMA PILOTA, CANALA PERIMETRALE ALLAGABILE, SCARICO CON FILTRO REMOVIBILE.**

**EN** Solid top gas - Plate.37x57cm. Electric ignition, flame presence indicator, floodable perimeter channel, drain with removable filter. • **DE** Gas-Kochplatte - Platte.37x57 cm. Elektrische Zündung, Flammenpräsenzanzeige, flutbaren Umfangskanal, Auspuff mit abnehmbarem Filter. • **FR** Toute plaque à gaz - Plaque cm.37x57. Allumage électrique, indicateur de présence de flamme, un conduit extérieur inondable, échappement avec filtre amovible. • **ES** Placa de cocción a gas - Placa cm.37x57. Ignición eléctrica, indicador externo de llama piloto, canal perimetral inundable, drenaje con filtro extraíble.  
**cm. 50x 80x 31h**



⚡ 7 kW 2.572,00  
6.020 kcal/h 58 / 0,33

⚡ 0,001 KW  
230V~  
50/60 Hz

**TPD-89G**  
28290950

**TUTTA PIASTRA GAS PIASTRA CM 77X57. ACCENSIONE ELETTRICA, INDICATORE PRESENZA FIAMMA PILOTA, CANALA PERIMETRALE ALLAGABILE, SCARICO CON FILTRO REMOVIBILE.**

**EN** Solid top gas - Plate.77x57cm. Electric ignition, flame presence indicator, floodable perimeter channel, drain with removable filter. • **DE** Gas-Kochplatte - Platte.77x57 cm. Elektrische Zündung, Flammenpräsenzanzeige, flutbaren Umfangskanal, Auspuff mit abnehmbarem Filter. • **FR** Toute plaque à gaz - Plaque cm.77x57. Allumage électrique, indicateur de présence de flamme, un conduit extérieur inondable, échappement avec filtre amovible. • **ES** Placa de cocción a gas - Placa cm.77x57. Ignición eléctrica, indicador externo de llama piloto, canal perimetral inundable, drenaje con filtro extraíble.  
**cm. 90x 80x 31h**



⚡ 12 kW 2.896,00  
10.320 kcal/h 129 / 0,44

⚡ 0,001 KW  
230V~  
50/60 Hz



# TUTTAPIASTRA GAS 90

MOD. \_\_\_\_\_  
COD. \_\_\_\_\_

DESCRIZIONE/DESCRIPTION/BEZEICHNUNG/DESCRIPTION/DESCRIPCIÓN  
DIMENSIONI/DIMENSIONS/ABMESSUNGEN/DIMENSIONS/DIMENSIONES

POTENZA/POWER/LEISTUNG/PUISSANCE/POTENCIA  
VOLTAGGIO/VOLTAGE/SPANNUNG/VOLTAGE/VOLTAJE

⚡ kW kcal/h  
⚡ kW V~ Hz

PREZZO/PRICE €  
PREIS/PRIX/PRECIO €  
KG / M<sup>3</sup>

TPD-95G  
29290550

**TUTTA PIASTRA GAS PIASTRA CM 39X73.  
ACCENSIONE ELETTRICA, INDICATORE  
PRESENZA FIAMMA PILOTA, CANALA  
PERIMETRALE ALLAGABILE, SCARICO CON  
FILTRO REMOVIBILE.**

**EN** Solid top gas - Plate.39x73 cm. Electric ignition, flame presence indicator, floodable perimeter channel, drain with removable filter. • **DE** Gas-Kochplatte - Platte.39x73 cm. Elektrische Zündung, Flammenpräsenzanzeige, flutbaren Umfangskanal, Auspuff mit abnehmbarem Filter. • **FR** Toute plaque à gaz - Plaque cm.39x73. Allumage électrique, indicateur de présence de flamme, un conduit extérieur inondable, échappement avec filtre amovible. • **ES** Placa de cocción a gas - Placa cm.39x73. Ignición eléctrica, indicador externo de llama piloto, canal perimetral inundable, drenaje con filtro extraíble.  
**cm. 50x 95x 31h**



⚡ 7 kW 2.650,00  
6.020 kcal/h 62 / 0,33

⚡ 0,001 KW  
230V~  
50/60 Hz

TPD-99G  
29290950

**TUTTA PIASTRA GAS PIASTRA CM 79X73.  
ACCENSIONE ELETTRICA, INDICATORE  
PRESENZA FIAMMA PILOTA, CANALA  
PERIMETRALE ALLAGABILE, SCARICO CON  
FILTRO REMOVIBILE.**

**EN** Solid top gas - Plate.79x73 cm. Electric ignition, flame presence indicator, floodable perimeter channel, drain with removable filter. • **DE** Gas-Kochplatte - Platte.79x73 cm. Elektrische Zündung, Flammenpräsenzanzeige, flutbaren Umfangskanal, Auspuff mit abnehmbarem Filter. • **FR** Toute plaque à gaz - Plaque cm.79x73. Allumage électrique, indicateur de présence de flamme, un conduit extérieur inondable, échappement avec filtre amovible. • **ES** Placa de cocción a gas - Placa cm.79x73. Ignición eléctrica, indicador externo de llama piloto, canal perimetral inundable, drenaje con filtro extraíble.  
**cm. 90x 95x 31h**



⚡ 12 kW 3.164,00  
10.320 kcal/h 135 / 0,64

⚡ 0,001 KW  
230V~  
50/60 Hz

FTLD-85GS  
28230554

**FRY-TOP GAS LISCIO CROMATO  
SUPERCHROME (MOCA APPROVED), PIASTRA  
CM.39X53,5. ACCENSIONE ELETTRICA,  
INDICATORE PRESENZA FIAMMA PILOTA,  
CANALA PERIMETRALE ALLAGABILE, SCARICO  
CON FILTRO REMOVIBILE.**

**EN** Gas Fry-top smooth chromed griddle SUPERCHROME (Moca Approved), plate cm.39x53,5. Electric ignition, flame presence indicator, floodable perimeter channel, drain with removable filter. • **DE** Gas-griddleplatte glatt hartverchromt SUPERCHROME (Moca Approved), platte cm.39x53,5. Elektrische Zündung, Flammenpräsenzanzeige, flutbaren Umfangskanal, Auspuff mit abnehmbarem Filter. • **FR** Plaque gaz lisse chromée SUPERCHROME (Moca Approved), plaque cm.39x53,5. Allumage électrique, indicateur de présence de flamme, un conduit extérieur inondable, échappement avec filtre amovible. • **ES** Fry-top gas liso cromado SUPERCHROME (Moca Approved), plancha cm.39x53,5. Ignición eléctrica, indicador externo de llama piloto, canal perimetral inundable, drenaje con filtro extraíble.  
**cm. 50x 80x 33h**



⚡ 7 kW 2.326,00  
6.020 kcal/h 53 / 0,33

⚡ 0,001 KW  
230V~  
50/60 Hz



Le immagini presentate non sono vincolanti. La ditta si riserva di apportare modifiche senza preavviso. • The pictures are purely representative. The manufacturer reserves the right to modify the technical data and models without previous notice. • Les images

LO

présentées ne nous engagent pas. La Société se réserve le droit d'apporter tout modification sans préavis. • Die dargestellten Abbildungen sind nicht verbindlich. Technische Änderungen vorbehalten. • Las imágenes presentadas no son vinculantes. El Fabricante se reserva el derecho de modificar sus productos sin previo aviso.

01/20

359

MOD. \_\_\_\_\_  
COD. \_\_\_\_\_

DESCRIZIONE/DESCRIPTION/BEZEICHNUNG/DESCRIPTION/DESCRIPCIÓN  
DIMENSIONI/DIMENSIONS/ABMESSUNGEN/DIMENSIONS/DIMENSIONES

POTENZA/POWER/LEISTUNG/PUISSANCE/POTENCIA  
VOLTAGGIO/VOLTAGE/SPANNUNG/VOLTAGE/VOLTAJE

⚡ kW  
kcal/h

⚡ kW  
V~  
Hz

PREZZO/PRICE €  
PREIS/PRIX/PRECIO €  
KG / M<sup>3</sup>

**FTRD-85GS**  
28230556

**FRY-TOP GAS RIGATO CROMATO SUPERCHROME (MOCA APPROVED), PIASTRA CM.39X53,5. ACCENSIONE ELETTRICA, INDICATORE PRESENZA FIAMMA PILOTA, CANALA PERIMETRALE ALLAGABILE, SCARICO CON FILTRO REMOVIBILE.**

**EN** Gas Fry-top grooved chromed griddle SUPERCHROME (Moca Approved), plate cm.39x53,5. Electric ignition, flame presence indicator, floodable perimeter channel, drain with removable filter. • **DE** Gas-griddleplatte gerillt hartverchromt SUPERCHROME (Moca Approved), platte cm.39x53,5. Elektrische Zündung, Flammenpräsenzanzeige, flutbaren Umfangskanal, Auspuff mit abnehmbarem Filter. • **FR** Plaque gaz nervurée chromée SUPERCHROME (Moca Approved), plaque cm.39x53,5. Allumage électrique, indicateur de présence de flamme, un conduit extérieur inondable, échappement avec filtre amovible. • **ES** Fry-top gas estriado cromado SUPERCHROME (Moca Approved), plancha cm.39x53,5. Ignición eléctrica, indicador externo de llama piloto, canal perimetral inundable, drenaje con filtro extraíble.  
**cm. 50x 80x 33h**



⚡ 7 kW  
6.020 kcal/h **2.450,00**  
53 / 0,33

⚡ 0,001 KW  
230V~  
50/60 Hz

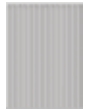

**FTLD-87GS**  
28230754

**FRY-TOP GAS LISCIO CROMATO SUPERCHROME (MOCA APPROVED), PIASTRA CM.59X53,5. ACCENSIONE ELETTRICA, INDICATORE PRESENZA FIAMMA PILOTA, CANALA PERIMETRALE ALLAGABILE, SCARICO CON FILTRO REMOVIBILE.**

**EN** Gas Fry-top smooth chromed griddle SUPERCHROME (Moca Approved), plate cm.59x53,5. Electric ignition, flame presence indicator, floodable perimeter channel, drain with removable filter. • **DE** Gas-griddleplatte glatt hartverchromt SUPERCHROME (Moca Approved), platte cm.59x53,5. Elektrische Zündung, Flammenpräsenzanzeige, flutbaren Umfangskanal, Auspuff mit abnehmbarem Filter. • **FR** Plaque gaz lisse chromée SUPERCHROME (Moca Approved), plaque cm.59x53,5. Allumage électrique, indicateur de présence de flamme, un conduit extérieur inondable, échappement avec filtre amovible. • **ES** Fry-top gas liso cromado SUPERCHROME (Moca Approved), plancha cm.59x53,5. Ignición eléctrica, indicador externo de llama piloto, canal perimetral inundable, drenaje con filtro extraíble.  
**cm. 70x 80x 33h**



⚡ 10,5 kW  
9.030 kcal/h **2.445,00**  
62 / 0,35

⚡ 0,001 KW  
230V~  
50/60 Hz



**FTLRD-87GS**  
28230755

**FRY-TOP GAS 1/2 RIGATO + 1/2 LISCIO CROMATO SUPERCHROME (MOCA APPROVED), PIASTRA CM.59X53,5. ACCENSIONE ELETTRICA, INDICATORE PRESENZA FIAMMA PILOTA, CANALA PERIMETRALE ALLAGABILE, SCARICO CON FILTRO REMOVIBILE.**

**EN** Gas Fry-top 1/2 grooved + 1/2 smooth chromed griddle SUPERCHROME (Moca Approved), plate cm.59x53,5. Electric ignition, flame presence indicator, floodable perimeter channel, drain with removable filter. • **DE** Gas-griddleplatte 1/2 gerillt + 1/2 glatt hartverchromt SUPERCHROME (Moca Approved), platte cm.59x53,5. Elektrische Zündung, Flammenpräsenzanzeige, flutbaren Umfangskanal, Auspuff mit abnehmbarem Filter. • **FR** Plaque gaz 1/2 nervurée + 1/2 lisse chromée SUPERCHROME (Moca Approved), plaque cm.59x53,5. Allumage électrique, indicateur de présence de flamme, un conduit extérieur inondable, échappement avec filtre amovible. • **ES** Fry-top gas 1/2 estriado + 1/2 liso cromado SUPERCHROME (Moca Approved), plancha cm.59x53,5. Ignición eléctrica, indicador externo de llama piloto, canal perimetral inundable, drenaje con filtro extraíble.  
**cm. 70x 80x 33h**



⚡ 10,5 kW  
9.030 kcal/h **2.550,00**  
62 / 0,35

⚡ 0,001 KW  
230V~  
50/60 Hz



MOD. \_\_\_\_\_  
COD. \_\_\_\_\_

DESCRIZIONE/DESCRIPTION/BEZEICHNUNG/DESCRIPTION/DESCRIPCIÓN  
DIMENSIONI/DIMENSIONS/ABMESSUNGEN/DIMENSIONS/DIMENSIONES

POTENZA/POWER/LEISTUNG/PUISSANCE/POTENCIA  
VOLTAGGIO/VOLTAGE/SPANNUNG/VOLTAGE/VOLTAJE

⚡ kW  
kcal/h

⚡ kW  
V~  
Hz

PREZZO/PRICE €  
PREIS/PRIX/PRECIO €  
KG / M<sup>3</sup>

**FTRD-87GS**  
28230756

**FRY-TOP GAS RIGATO CROMATO SUPERCHROME (MOCA APPROVED), PIASTRA CM.59X53,5. ACCENSIONE ELETTRICA, INDICATORE PRESENZA FIAMMA PILOTA, CANALA PERIMETRALE ALLAGABILE, SCARICO CON FILTRO REMOVIBILE.**

**EN** Gas Fry-top grooved chromed griddle SUPERCHROME (Moca Approved), plate cm.59x53,5. Electric ignition, flame presence indicator, floodable perimeter channel, drain with removable filter. • **DE** Gas-griddleplatte gerillt hartverchromt SUPERCHROME (Moca Approved), platte cm.59x53,5. Elektrische Zündung, Flammenpräsenzanzeige, flutbaren Umfangskanal, Auspuff mit abnehmbarem Filter. • **FR** Plaque gaz nervurée chromée SUPERCHROME (Moca Approved), plaque cm.59x53,5. Allumage électrique, indicateur de présence de flamme, un conduit extérieur inondable, échappement avec filtre amovible. • **ES** Fry-top gas estriado cromado SUPERCHROME (Moca Approved), plancha cm.59x53,5. Ignición eléctrica, indicador externo de llama piloto, canal perimetral inundable, drenaje con filtro extraíble.  
**cm. 70x 80x 33h**



⚡ 10,5 kW  
9.030 kcal/h

**2.631,00**  
62 / 0,35

⚡ 0,001 KW  
230V~  
50/60 Hz



**FTLD-89GS**  
28230954

**FRY-TOP GAS LISCIO CROMATO SUPERCHROME (MOCA APPROVED), PIASTRA CM.79X53,5 - 2 ZONE DI COTTURA. ACCENSIONE ELETTRICA, INDICATORE PRESENZA FIAMMA PILOTA, CANALA PERIMETRALE ALLAGABILE, SCARICO CON FILTRO REMOVIBILE.**

**EN** Gas Fry-top smooth chromed griddle SUPERCHROME (Moca Approved), plate cm.79x53,5 - 2 cooking areas. Electric ignition, flame presence indicator, floodable perimeter channel, drain with removable filter. • **DE** Gas-griddleplatte glatt hartverchromt SUPERCHROME (Moca Approved), platte cm.79x53,5 - 2 Heizzonen. Elektrische Zündung, Flammenpräsenzanzeige, flutbaren Umfangskanal, Auspuff mit abnehmbarem Filter. • **FR** Plaque gaz lisse chromée SUPERCHROME (Moca Approved), plaque cm.79x53,5 - 2 zones de cuisson. Allumage électrique, indicateur de présence de flamme, un conduit extérieur inondable, échappement avec filtre amovible. • **ES** Fry-top gas liso cromado SUPERCHROME (Moca Approved), plancha cm.79x53,5 - 2 zonas de cocción. Ignición eléctrica, indicador externo de llama piloto, canal perimetral inundable, drenaje con filtro extraíble.  
**cm. 90x 80x 33h**



⚡ 14 kW  
12.040 kcal/h

**3.118,00**  
98 / 0,44

⚡ 0,001 KW  
230V~  
50/60 Hz



**FTLRD-89GS**  
28230955

**FRY-TOP GAS 1/2 RIGATO + 1/2 LISCIO CROMATO SUPERCHROME (MOCA APPROVED), PIASTRA CM.79X53,5 - 2 ZONE DI COTTURA. ACCENSIONE ELETTRICA, INDICATORE PRESENZA FIAMMA PILOTA, CANALA PERIMETRALE ALLAGABILE, SCARICO CON FILTRO REMOVIBILE.**

**EN** Gas Fry-top 1/2 grooved + 1/2 smooth chromed griddle SUPERCHROME (Moca Approved), plate cm.79x53,5 - 2 cooking areas. Electric ignition, flame presence indicator, floodable perimeter channel, drain with removable filter. • **DE** Gas-griddleplatte 1/2 gerillt + 1/2 glatt hartverchromt SUPERCHROME (Moca Approved), platte cm.79x53,5 - 2 Heizzonen. Elektrische Zündung, Flammenpräsenzanzeige, flutbaren Umfangskanal, Auspuff mit abnehmbarem Filter. • **FR** Plaque gaz 1/2 nervurée + 1/2 lisse chromée SUPERCHROME (Moca Approved), plaque cm.79x53,5 - 2 zones de cuisson. Allumage électrique, indicateur de présence de flamme, un conduit extérieur inondable, échappement avec filtre amovible. • **ES** Fry-top gas 1/2 estriado + 1/2 liso cromado SUPERCHROME (Moca Approved), plancha cm.79x53,5 - 2 zonas de cocción. Ignición eléctrica, indicador externo de llama piloto, canal perimetral inundable, drenaje con filtro extraíble.  
**cm. 90x 80x 33h**



⚡ 14 kW  
12.040 kcal/h

**3.260,00**  
98 / 0,44

⚡ 0,001 KW  
230V~  
50/60 Hz



MOD. \_\_\_\_\_  
COD. \_\_\_\_\_

DESCRIZIONE/DESCRIPTION/BEZEICHNUNG/DESCRIPTION/DESCRIPCIÓN  
DIMENSIONI/DIMENSIONS/ABMESSUNGEN/DIMENSIONS/DIMENSIONES

POTENZA/POWER/LEISTUNG/PUISSANCE/POTENCIA  
VOLTAGGIO/VOLTAGE/SPANNUNG/VOLTAGE/VOLTAJE

⚡ kW  
kcal/h

⚡ kW  
V~  
Hz

PREZZO/PRICE €  
PREIS/PRIX/PRECIO €  
KG / M<sup>3</sup>

**FTRD-89GS**  
28230956

**FRY-TOP GAS RIGATO CROMATO SUPERCHROME (MOCA APPROVED), PIASTRA CM.79X53,5 - 2 ZONE DI COTTURA. ACCENSIONE ELETTRICA, INDICATORE PRESENZA FIAMMA PILOTA, CANALA PERIMETRALE ALLAGABILE, SCARICO CON FILTRO REMOVIBILE.**

**EN** Gas Fry-top grooved chromed griddle SUPERCHROME (Moca Approved), plate cm.79x53,5 - 2 cooking areas. Electric ignition, flame presence indicator, floodable perimeter channel, drain with removable filter. • **DE** Gas-griddleplatte gerillt hartverchromt SUPERCHROME (Moca Approved), platte cm.79x53,5 - 2 Heizzonen. Elektrische Zündung, Flammenpräsenzanzeige, flutbaren Umfangskanal, Auspuff mit abnehmbarem Filter. • **FR** Plaque gaz nervurée chromée SUPERCHROME (Moca Approved), plaque cm.79x53,5 - 2 zones de cuisson. Allumage électrique, indicateur de présence de flamme, un conduit extérieur inondable, échappement avec filtre amovible. • **ES** Fry-top gas estriado cromado SUPERCHROME (Moca Approved), plancha cm.79x53,5 - 2 zonas de cocción. Ignición eléctrica, indicador externo de llama piloto, canal perimetral inundable, drenaje con filtro extraíble.c

**cm. 90x 80x 33h**



⚡ 14 kW  
12.040 kcal/h **3.410,00**  
98 / 0,44

⚡ 0,001 KW  
230V~  
50/60 Hz



**FILD-95GS**  
29230554

**FRY-TOP GAS LISCIO CROMATO SUPERCHROME (MOCA APPROVED), PIASTRA CM.39X68,5. ACCENSIONE ELETTRICA, INDICATORE PRESENZA FIAMMA PILOTA, CANALA PERIMETRALE ALLAGABILE, SCARICO CON FILTRO REMOVIBILE.**

**EN** Gas Fry-top smooth chromed griddle SUPERCHROME (Moca Approved), plate cm.39x68,5. Electric ignition, flame presence indicator, floodable perimeter channel, drain with removable filter. • **DE** Gas-griddleplatte glatt hartverchromt SUPERCHROME (Moca Approved), platte cm.39x68,5. Elektrische Zündung, Flammenpräsenzanzeige, flutbaren Umfangskanal, Auspuff mit abnehmbarem Filter. • **FR** Plaque gaz lisse chromée SUPERCHROME (Moca Approved), plaque cm.39x68,5. Allumage électrique, indicateur de présence de flamme, un conduit extérieur inondable, échappement avec filtre amovible. • **ES** Fry-top gas liso cromado SUPERCHROME (Moca Approved), plancha cm.39x68,5. Ignición eléctrica, indicador externo de llama piloto, canal perimetral inundable, drenaje con filtro extraíble.

**cm. 50x 95x 33h**



⚡ 9 kW  
7.740 kcal/h **2.678,00**  
61 / 0,33

⚡ 0,001 KW  
230V~  
50/60 Hz



**FTRD-95GS**  
29230556

**FRY-TOP GAS RIGATO CROMATO SUPERCHROME (MOCA APPROVED), PIASTRA CM.39X68,5. ACCENSIONE ELETTRICA, INDICATORE PRESENZA FIAMMA PILOTA, CANALA PERIMETRALE ALLAGABILE, SCARICO CON FILTRO REMOVIBILE.**

**EN** Gas Fry-top grooved chromed griddle SUPERCHROME (Moca Approved), plate cm.39x68,5. Electric ignition, flame presence indicator, floodable perimeter channel, drain with removable filter. • **DE** Gas-griddleplatte gerillt hartverchromt SUPERCHROME (Moca Approved), platte cm.39x68,5. Elektrische Zündung, Flammenpräsenzanzeige, flutbaren Umfangskanal, Auspuff mit abnehmbarem Filter. • **FR** Plaque gaz nervurée chromée SUPERCHROME (Moca Approved), plaque cm.39x68,5. Allumage électrique, indicateur de présence de flamme, un conduit extérieur inondable, échappement avec filtre amovible. • **ES** Fry-top gas estriado cromado SUPERCHROME (Moca Approved), plancha cm.39x68,5. Ignición eléctrica, indicador externo de llama piloto, canal perimetral inundable, drenaje con filtro extraíble.

**cm. 50x 95x 33h**



⚡ 9 kW  
7.740 kcal/h **2.820,00**  
61 / 0,33

⚡ 0,001 KW  
230V~  
50/60 Hz





# FRY-TOP A GAS 90

MOD. \_\_\_\_\_  
COD. \_\_\_\_\_

DESCRIZIONE/DESCRIPTION/BEZEICHNUNG/DESCRIPTION/DESCRIPCIÓN  
DIMENSIONI/DIMENSIONS/ABMESSUNGEN/DIMENSIONS/DIMENSIONES

POTENZA/POWER/LEISTUNG/PUISSANCE/POTENCIA  
VOLTAGGIO/VOLTAGE/SPANNUNG/VOLTAGE/VOLTAJE

⚡ kW  
kcal/h

⚡ kW  
V~  
Hz

PREZZO/PRICE €  
PREIS/PRIX/PRECIO €  
KG / M<sup>3</sup>

**FTLD-99GS**  
29230954

**FRY-TOP GAS LISCIO CROMATO SUPERCHROME (MOCA APPROVED), PIASTRA CM.79X68,5 - 2 ZONE DI COTTURA. ACCENSIONE ELETTRICA, INDICATORE PRESENZA FIAMMA PILOTA, CANALA PERIMETRALE ALLAGABILE, SCARICO CON FILTRO REMOVIBILE.**

**EN** Gas Fry-top smooth chromed griddle SUPERCHROME (Moca Approved), plate cm.79x68,5 - 2 cooking areas. Electric ignition, flame presence indicator, floodable perimeter channel, drain with removable filter. • **DE** Gas-griddleplatte glatt hartverchromt SUPERCHROME (Moca Approved), platte cm.79x68,5 - 2 Heizzonen. Elektrische Zündung, Flammenpräsenzanzeige, flutbaren Umfangskanal, Auspuff mit abnehmbarem Filter. • **FR** Plaque gaz lisse chromée SUPERCHROME (Moca Approved), plaque cm.79x68,5 - 2 zones de cuisson. Allumage électrique, indicateur de présence de flamme, un conduit extérieur inondable, échappement avec filtre amovible. • **ES** Fry-top gas liso cromado SUPERCHROME (Moca Approved), plancha cm.79x68,5 - 2 zonas de cocción. Ignición eléctrica, indicador externo de llama piloto, canal perimetral inundable, drenaje con filtro extraíble. **cm. 90x 95x 33h**



⚡ 18 kW  
15.480 kcal/h

**3.805,00**  
102 / 0,64

⚡ 0,001 KW  
230V~  
50/60 Hz

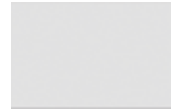

**FTLRD-99GS**  
29230955

**FRY-TOP GAS 1/2 RIGATO + 1/2 LISCIO CROMATO SUPERCHROME (MOCA APPROVED), PIASTRA CM.79X68,5 - 2 ZONE DI COTTURA. ACCENSIONE ELETTRICA, INDICATORE PRESENZA FIAMMA PILOTA, CANALA PERIMETRALE ALLAGABILE, SCARICO CON FILTRO REMOVIBILE.**

**EN** Gas Fry-top 1/2 grooved + 1/2 smooth chromed griddle SUPERCHROME (Moca Approved), plate cm.79x68,5 - 2 cooking areas. Electric ignition, flame presence indicator, floodable perimeter channel, drain with removable filter. • **DE** Gas-griddleplatte 1/2 gerillt + 1/2 glatt hartverchromt SUPERCHROME (Moca Approved), platte cm.79x68,5 - 2 Heizzonen. Elektrische Zündung, Flammenpräsenzanzeige, flutbaren Umfangskanal, Auspuff mit abnehmbarem Filter. • **FR** Plaque gaz 1/2 nervurée + 1/2 lisse chromée SUPERCHROME (Moca Approved), plaque cm.79x68,5 - 2 zones de cuisson. Allumage électrique, indicateur de présence de flamme, un conduit extérieur inondable, échappement avec filtre amovible. • **ES** Fry-top gas 1/2 estriado + 1/2 liso cromado SUPERCHROME (Moca Approved), plancha cm.79x68,5 - 2 zonas de cocción. Ignición eléctrica, indicador externo de llama piloto, canal perimetral inundable, drenaje con filtro extraíble. **cm. 90x 95x 33h**



⚡ 18 kW  
15.480 kcal/h

**3.980,00**  
102 / 0,64

⚡ 0,001 KW  
230V~  
50/60 Hz





MOD. \_\_\_\_\_  
COD. \_\_\_\_\_

DESCRIZIONE/DESCRIPTION/BEZEICHNUNG/DESCRIPTION/DESCRIPCIÓN  
DIMENSIONI/DIMENSIONS/ABMESSUNGEN/DIMENSIONS/DIMENSIONES

POTENZA/POWER/LEISTUNG/PUISSANCE/POTENCIA  
VOLTAGGIO/VOLTAGE/SPANNUNG/VOLTAGE/VOLTAJE

⚡ kW \_\_\_\_\_  
kcal/h \_\_\_\_\_  
⚡ kW \_\_\_\_\_  
V~ \_\_\_\_\_  
Hz \_\_\_\_\_

PREZZO/PRICE € \_\_\_\_\_  
PREIS/PRIX/PRECIO € \_\_\_\_\_  
KG / M<sup>3</sup> \_\_\_\_\_

**FTRD-99GS**  
29230956

**FRY-TOP GAS RIGATO CROMATO SUPERCHROME (MOCA APPROVED), PIASTRA CM.79X68,5 - 2 ZONE DI COTTURA. ACCENSIONE ELETTRICA, INDICATORE PRESENZA FIAMMA PILOTA, CANALA PERIMETRALE ALLAGABILE, SCARICO CON FILTRO REMOVIBILE.**

**EN** Gas Fry-top grooved chromed griddle SUPERCHROME (Moca Approved), plate cm.79x68,5 - 2 cooking areas. Electric ignition, flame presence indicator, floodable perimeter channel, drain with removable filter. • **DE** Gas-griddleplatte gerillt hartverchromt SUPERCHROME (Moca Approved), platte cm.79x68,5 - 2 Heizzonen. Elektrische Zündung, Flammenpräsenzanzeige, flutbaren Umfangskanal, Auspuff mit abnehmbarem Filter. • **FR** Plaque gaz nervurée chromée SUPERCHROME (Moca Approved), plaque cm.79x68,5 - 2 zones de cuisson. Allumage électrique, indicateur de présence de flamme, un conduit extérieur inondable, échappement avec filtre amovible. • **ES** Fry-top gas estriado cromado SUPERCHROME (Moca Approved), plancha cm.79x68,5 - 2 zonas de cocción. Ignición eléctrica, indicador externo de llama piloto, canal perimetral inundable, drenaje con filtro extraíble.  
**cm. 90x 95x 33h**



⚡ 18 kW \_\_\_\_\_ **4.156,00**  
15.480 kcal/h 102 / 0,64

⚡ 0,001 KW \_\_\_\_\_  
230V~ \_\_\_\_\_  
50/60 Hz \_\_\_\_\_



**LAD-64**  
26020400

**LAVELLO RUBINETTO A LEVA - VASCA CM. 34X34X20H**

**EN** Sink unit - Lever type tap. Bowl cm. 34x34x20h • **DE** Spülbecken Einhebel-Mischbatterie - Becken cm. 34x34x20h • **FR** Bac-évier avec robinetterie - Bac cm. 34x34x20h • **ES** Fregadero - Grifo a palanca - Pileta cm. 34x34x20h  
**cm. 40x 60x 35h**



**736,00**  
15 / 0,13

**OPT-GA**

**ACCENSIONE ELETTRICA PER APPARECCHI GAS: PCD-64GA, PCD-68GA (PREZZO A BRUCIATORE)**

**EN** electric ignition for gas model: PCD-64GA, PCD-68GA (PRICE FOR 1 BURNER) • **DE** elektrische Zündung für gas modell: PCD-64GA, PCD-68GA (PREIS FÜR 1 BRENNER) • **FR** allumage électrique pour modèle a gaz: PCD-64GA, PCD-68GA (PRIX POUR 1 BRÛLEUR) • **ES** ignición eléctrica para modelo gas: PCD-64GA, PCD-68GA (PRECIO POR 1 QUEMADOR)



⚡ 0,01 KW \_\_\_\_\_ **200,00**  
230V~ \_\_\_\_\_ /  
50/60 Hz \_\_\_\_\_

**532005901**

**GRIGLIA 1 FUOCO**

**EN** 1 flame grill • **DE** Rost 1 flamme • **FR** Frille 1 feu • **ES** Parilla 1 quemador

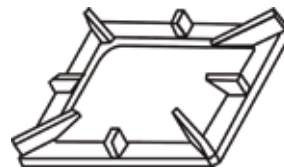

**86,00**  
3 / 0,01

**PLF**  
07590401

**PIASTRA LISCIA PER GRIGLIA IN GHISA**

**EN** Smooth griddle plate for cast iron grid • **DE** Fortkochplatte glatt für Gusseisen Rost • **FR** Plaque lisse pour la grille en fonte • **ES** Plancha lisa para rejilla de hierro fundido  
**cm. 35x 27**



**151,00**  
9 / 0,01

MOD. \_\_\_\_\_  
COD. \_\_\_\_\_

DESCRIZIONE/DESCRIPTION/BEZEICHNUNG/DESCRIPTION/DESCRIPCIÓN  
DIMENSIONI/DIMENSIONS/ABMESSUNGEN/DIMENSIONS/DIMENSIONES

POTENZA/POWER/LEISTUNG/PUISSANCE/POTENCIA  
VOLTAGGIO/VOLTAGE/SPANNUNG/VOLTAGE/VOLTAJE

⚡ kW kcal/h  
⚡ kw V~ Hz

PREZZO/PRICE €  
PREIS/PRIX/PRECIO €  
KG / M<sup>3</sup>

**PLF/2**  
07590421

**PIASTRA LISCIA 2 FUOCHI PER GRIGLIA IN GHISA**

**EN** Smooth griddle plate 2 burners for cast iron grid  
• **DE** Fortkochplatte glatt 2 Kochstellen für Gusseisen Rost  
• **FR** Plaque lisse 2 feux pour la grille en fonte  
• **ES** Plancha lisa 2 quemadores para rejilla de hierro fundido  
**cm. 35x 57**



**299,00**  
18 / 0,01

**PRF**  
07590403

**PIASTRA RIGATA PER GRIGLIA IN GHISA**

**EN** Grooved griddle plate for cast iron grid  
• **DE** Fortkochplatte gerillt für Gusseisen Rost  
• **FR** Plaque nervurée pour la grille en fonte  
• **ES** Plancha estriada para rejilla de hierro fundido  
**cm. 35x 27**

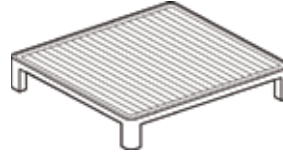

**203,00**  
9 / 0,01

**PRF/2**  
07590423

**PIASTRA RIGATA 2 FUOCHI PER GRIGLIA IN GHISA**

**EN** Grooved griddle plate 2 burners for cast iron grid  
• **DE** Fortkochplatte gerillt 2 Kochstellen für Gusseisen Rost  
• **FR** Plaque nervurée 2 feux pour la grille en fonte  
• **ES** Plancha estriada 2 quemadores para rejilla de hierro fundido  
**cm. 35x 57**



**332,00**  
18 / 0,01

**PLFT/7**  
08590451

**PIASTRA LISCIA PER GRIGLIA IN TONDINO**

**EN** Smooth griddle plate for grid rod  
• **DE** Fortkochplatte glatt für Gitterstab  
• **FR** Plaque lisse pour tige grille  
• **ES** Plancha lisa por red de varilla  
**cm. 35x 27**



**151,00**  
9 / 0,01

**PLFT/72**  
08590471

**PIASTRA LISCIA 2 FUOCHI PER GRIGLIA IN TONDINO**

**EN** Smooth griddle plate 2 burners for grid rod  
• **DE** Fortkochplatte glatt 2 Kochstellen für Gitterstab  
• **FR** Plaque lisse 2 feux pour tige grille  
• **ES** Plancha lisa 2 quemadores por red de varilla  
**cm. 35x 57**



**299,00**  
18 / 0,01

**PRFT/7**  
08590453

**PIASTRA RIGATA PER GRIGLIA IN TONDINO**

**EN** Grooved griddle plate for grid rod  
• **DE** Fortkochplatte gerillt für Gitterstab  
• **FR** Plaque nervurée pour tige grille  
• **ES** Plancha estriada por red de varilla  
**cm. 35x 27**

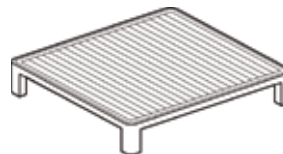

**203,00**  
9 / 0,01

**PRFT/72**  
08590473

**PIASTRA RIGATA 2 FUOCHI PER GRIGLIA IN TONDINO**

**EN** Grooved griddle plate 2 burners for grid rod  
• **DE** Fortkochplatte gerillt 2 Kochstellen für Gitterstab  
• **FR** Plaque nervurée 2 feux pour tige grille  
• **ES** Plancha estriada 2 quemadores por red de varilla  
**cm. 35x 57**



**332,00**  
18 / 0,01

**KIT-WOK**  
09580040

**KIT WOK - FIAMMA VERTICALE - SOLO SU BRUCIATORE DA 10 KW E GRIGLIE IN GHISA**

**EN** KIT WOK - vertical flame - only for 10 kW burner and cast iron grills  
• **DE** KIT WOK - vertikaler Flamme - nur 10 kW-Brenner und Roste aus Gusseisen  
• **FR** KIT WOK - verticale de la flamme - seulement 10 kW brûleur et grilles en fonte  
• **ES** KIT WOK - llama vertical - sólo 10 kW quemador y parrilas de hierro colado  
**cm. Ø 26x 16h**



**337,00**  
5 / 0,02



Le immagini presentate non sono vincolanti. La ditta si riserva di apportare modifiche senza preavviso. • The pictures are purely representative. The manufacturer reserves the right to modify the technical data and models without previous notice. • Les images

**LO**

présentées ne nous engagent pas. La Société se réserve le droit d'apporter tout modification sans préavis. • Die dargestellten Abbildungen sind nicht verbindlich. Technische Änderungen vorbehalten. • Las imágenes presentadas no son vinculantes. El Fabricante se reserva el derecho de modificar sus productos sin previo aviso.

01/20

**365**

MOD. \_\_\_\_\_  
COD. \_\_\_\_\_

DESCRIZIONE/DESCRIPTION/BEZEICHNUNG/DESCRIPTION/DESCRIPCIÓN  
DIMENSIONI/DIMENSIONS/ABMESSUNGEN/DIMENSIONS/DIMENSIONES

POTENZA/POWER/LEISTUNG/PUISSANCE/POTENCIA  
VOLTAGGIO/VOLTAGE/SPANNUNG/VOLTAGE/VOLTAJE

↓ kW kcal/h  
↑ kw V~ Hz

PREZZO/PRICE €  
PREIS/PRIX/PRECIO €  
KG / M<sup>3</sup>

**533009200 GRIGLIA DI RIDUZIONE**  
**EN** Reduction • **DE** Reduzierstern • **FR** Grille de réduction • **ES** Rejilla de reducción  
**cm. 25x 25**



**31,00**  
0.2 / 0,00

**531070200 CESTO 1/1 PER CPD-64 - 2/3 PER CPD-84**  
**EN** Basket 1/1 for CPD-64 - 2/3 for CPD-84 • **DE** Korb 1/1 für CPD-64 - 2/3 für CPD-84 • **FR** Panier 1/1 pour CPD-64 - 2/3 pour CPD-84 • **ES** Cesta 1/1 para CPD-64 - 2/3 para CPD-84  
**cm. 28x 32x 21,5h**



**136,00**  
2 / 0,06

**531032400 CESTO 1/2 PER CPD-64**  
**EN** Basket 1/2 for CPD-64 • **DE** Korb 1/2 für CPD-64 • **FR** Panier 1/2 pour CPD-64 • **ES** Cesta 1/2 para CPD-64  
**cm. 14x 32x 20h**

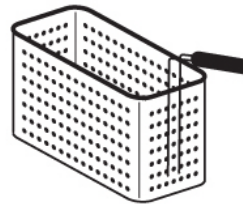

**94,00**  
1.5 / 0,05

..324..

**531047900 CESTO 1/2 PER CPD-64 - 1/3 PER CPD-84**  
**EN** Basket 1/2 for CPD-64 - 1/3 for CPD-84 • **DE** Korb 1/2 für CPD-64 - 1/3 für CPD-84 • **FR** Panier 1/2 pour CPD-64 - 1/3 pour CPD-84 • **ES** Cesta 1/2 para CPD-64 - 1/3 para CPD-84  
**cm. 28x 16x 21,5h**



**98,00**  
1.5 / 0,04

**531048000 CESTO 1/4 PER CPD-64 - 1/6 PER CPD-84**  
**EN** Basket 1/4 for CPD-64 - 1/6 for CPD-84 • **DE** Korb 1/4 für CPD-64 - 1/6 für CPD-84 • **FR** Panier 1/4 pour CPD-64 - 1/6 pour CPD-84 • **ES** Cesta 1/4 para CPD-64 - 1/6 para CPD-84  
**cm. 13,5x 16x 21,5h**



**75,00**  
1 / 0,02

**531032600 CESTO 1/6 PER CPD-64**  
**EN** Basket 1/6 for CPD-64 • **DE** Korb 1/6 für CPD-64 • **FR** Panier 1/6 pour CPD-64 • **ES** Cesta 1/6 para CPD-64  
**cm. 14x 10x 20h**



**67,00**  
0.7 / 0,02

..326..

# ACCESSORI CUOCIPASTA

MOD. \_\_\_\_\_  
COD. \_\_\_\_\_

DESCRIZIONE/DESCRIPTION/BEZEICHNUNG/DESCRIPTION/DESCRIPCIÓN  
DIMENSIONI/DIMENSIONS/ABMESSUNGEN/DIMENSIONS/DIMENSIONES

POTENZA/POWER/LEISTUNG/PUISSANCE/POTENCIA  
VOLTAGGIO/VOLTAGE/SPANNUNG/VOLTAGE/VOLTAJE

⚡ kW kcal/h  
⚡ kW V~ Hz

PREZZO/PRICE €  
PREIS/PRIX/PRECIO €  
KG / M<sup>3</sup>

## 531070300 CESTO 1/1 PER CPD-84

EN Basket 1/1 for CPD-84 • DE Korb 1/1 für CPD-84  
• FR Panier 1/1 pour CPD-84 • ES Cesta 1/1 para CPD-84  
cm. 28x 49x 21,5h



198,00  
3,5 / 0,08

## 531070100 CESTO 1/2 PER CPD-84

EN Basket 1/2 for CPD-84 • DE Korb 1/2 für CPD-84  
• FR Panier 1/2 pour CPD-84 • ES Cesta 1/2 para CPD-84  
cm. 28x 24x 21,5h



124,00  
1 / 0,05

## 531071100 CESTO CON GANCIO 1/2 PER CPD-64

EN Basket with hook 1/2 for CPD-64 • DE Korb mit Haken 1/2 für CPD-64 • FR Panier avec crochet 1/2 pour CPD-64 • ES Cesta con gancho 1/2 para CPD-64  
cm. 14,5x 29x 20h



131,00  
1.5 / 0,05

## 531069300 GRIGLIA SUPPORTO CESTI CON GANCIO PER CPD-64

EN support for baskets with hook for CPD-64 • DE Unterstützung für Körbe mit Haken für CPD-64 • FR soutien pour les paniers avec crochet pour CPD-64 • ES soporte para cestas con gancho para CPD-64  
cm. 30x 33x 41h



112,00  
3.5 / 0,06

## 08550400 COPERCHIO BRFD-64

EN Lid BRFD-64 • DE Deckel BRFD-64 • FR Couvercle BRFD-64 • ES Tapa BRFD-64  
cm. 32x 53x 5h



113,00  
2 / 0,02

## 531013200 CESTO 1/2 PER F10D-E

EN Basket 1/2 for F10D-E • DE Korb 1/2 for F10D-E  
• FR Panier 1/2 for F10D-E • ES Cesta 1/2 for F10D-E  
cm. 10x 30x 12h



47,00  
0.7 / 0,03

## 531041600 CESTINO 1/2 PER F18D-64E

EN Basket 1/2 for F18D-64E • DE Korb 1/2 zur Friteuse F18D-64E • FR Panier 1/2 pour F18D-64E  
• ES Cesta 1/2 para F18D-64E  
cm. 13,5x 29x 15h



62,00  
0.8 / 0,04



Le immagini presentate non sono vincolanti. La ditta si riserva di apportare modifiche senza preavviso. • The pictures are purely representative. The manufacturer reserves the right to modify the technical data and models without previous notice. • Les images

LO

présentées ne nous engagent pas. La Société se réserve le droit d'apporter tout modification sans préavis. • Die dargestellten Abbildungen sind nicht verbindlich. Technische Änderungen vorbehalten. • Las imágenes presentadas no son vinculantes. El Fabricante se reserva el derecho de modificar sus productos sin previo aviso.

01/20

367







# STRUTTURE SBALZO 1 LATO S90

MOD. \_\_\_\_\_  
COD. \_\_\_\_\_

DESCRIZIONE/DESCRIPTION/BEZEICHNUNG/DESCRIPTION/DESCRIPCIÓN  
DIMENSIONI/DIMENSIONS/ABMESSUNGEN/DIMENSIONS/DIMENSIONES

POTENZA/POWER/LEISTUNG/PUISSANCE/POTENCIA  
VOLTAGGIO/VOLTAGE/SPANNUNG/VOLTAGE/VOLTAJE

$\frac{kW}{kcal/h}$   $\frac{V}{Hz}$

PREZZO/PRICE €  
PREIS/PRIX/PRECIO €  
KG / M<sup>3</sup>

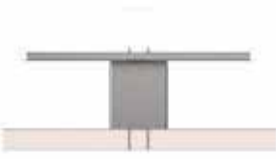
<b>SB90T-2,0</b> 01509200	<b>STRUTTURA SBALZO 1 LATO SERIE 90T, 1 PIEDE PER FISSAGGIO A TERRA</b> EN CANTILEVER STRUCTURE 1 side S90T, 1 foot for ground fixing • DE BRÜCKENSTRUKTURE 1 seite S90T, 1 steher für bodenverankerung • FR STRUCTURE SUSPENDUES 1 coté S90T, 1 pied pour le fixage au sol • ES ESTRUCTURA SUSPENDIDA 1 lado S90T, 1 pata para fijacion al suelo <b>cm. 200x113,8x 90h</b>		<b>2.984,00</b> 113 / 1,62
<b>SB90T-2,4</b> 01509240	<b>cm. 240x113,8x 90h</b>		<b>3.204,00</b> 123 / 1,93
<b>SB90T-2,8</b> 01509280	<b>STRUTTURA SBALZO 1 LATO SERIE 90T, 2 PIEDI PER FISSAGGIO A TERRA</b> EN CANTILEVER STRUCTURE 1 side S90T, 2 feet for ground fixing • DE BRÜCKENSTRUKTURE 1 seite S90T, 2 stehern für bodenverankerung • FR STRUCTURE SUSPENDUES 1 coté S90T, 2 pieds pour le fixage au sol • ES ESTRUCTURA SUSPENDIDA 1 lado S90T, 2 patas para fijacion al suelo <b>cm. 280x113,8x 90h</b>		<b>4.534,00</b> 194 / 2,23
<b>SB90T-3,2</b> 01509320	<b>cm. 320x113,8x 90h</b>		<b>4.753,00</b> 221 / 2,54
<b>SB90T-3,6</b> 01509360	<b>cm. 360x113,8x 90h</b>		<b>4.973,00</b> 242 / 2,85
<b>SB90T-4,0</b> 01509400	<b>cm. 400x113,8x 90h</b>		<b>5.192,00</b> 263 / 3,16
<b>SB90T-4,4</b> 01509440	<b>cm. 440x113,8x 90h</b>		<b>5.411,00</b> 290 / 3,47
<b>SB90T-4,8</b> 01509480	<b>cm. 480x113,8x 90h</b>		<b>5.631,00</b> 311 / 3,77
<b>SB90T-5,2</b> 01509520	<b>cm. 520x113,8x 90h</b>		<b>5.851,00</b> 338 / 4,08
<b>SB90T-5,6</b> 01509560	<b>cm. 560x113,8x 90h</b>		<b>6.071,00</b> 359 / 4,39
<b>SB90T-6,0</b> 01509600	<b>cm. 600x113,8x 90h</b>		<b>6.290,00</b> 380 / 4,70
<b>SB99T-2,0</b> 01599200	<b>STRUTTURA SBALZO 2 LATI SERIE 90T, 1 PIEDE PER FISSAGGIO A TERRA</b> EN CANTILEVER STRUCTURE 2 sides S90T, 1 foot for ground fixing • DE BRÜCKENSTRUKTURE 2 seiten S90T, 1 steher für bodenverankerung • FR STRUCTURE SUSPENDUES 2 cotés S90T, 1 pied pour le fixage au sol • ES ESTRUCTURA SUSPENDIDA 2 lados S90T, 1 pata para fijacion al suelo <b>cm. 200x 200x 90h</b>		<b>3.298,00</b> 136 / 2,79
<b>SB99T-2,4</b> 01599240	<b>cm. 240x 200x 90h</b>		<b>3.590,00</b> 149 / 3,33

# STRUTTURE SBALZO 2 LATI S90

MOD. COD.	DESCRIZIONE/DESCRIPTION/BEZEICHNUNG/DESCRIPTION/DESCRIPCIÓN DIMENSIONI/DIMENSIONS/ABMESSUNGEN/DIMENSIONS/DIMENSIONES	POTENZA/POWER/LEISTUNG/PUISSANCE/POTENCIA VOLTAGGIO/VOLTAGE/SPANNUNG/VOLTAGE/VOLTAJE	↓ kW kcal/h	↑ kW V~ Hz	PREZZO/PRICE PREIS/PRIX/PRECIO € KG / M <sup>3</sup>
<b>SB99T-2,8</b> 01599280	<b>STRUTTURA SBALZO 2 LATI SERIE 90T, 2 PIEDI PER FISSAGGIO A TERRA</b> EN CANTILEVER STRUCTURE 2 sides S90T, 2 feet for ground fixing • DE BRÜCKENSTRUKTURE 2 seiten S90T, 2 stehern für bodenverankerung • FR STRUCTURE SUSPENDUES 2 cotés S90T, 2 pieds pour le fixage au sol • ES ESTRUCTURA SUSPENDIDA 2 lados S90T, 2 patas para fijacion al suelo <b>cm. 280x 200x 90h</b>				<b>4.953,00</b> 226 / 3,86
<b>SB99T-3,2</b> 01599320	<b>cm. 320x 200x 90h</b>				<b>5.246,00</b> 257 / 4,39
<b>SB99T-3,6</b> 01599360	<b>cm. 360x 200x 90h</b>				<b>5.538,00</b> 281 / 4,92
<b>SB99T-4,0</b> 01599400	<b>cm. 400x 200x 90h</b>				<b>5.830,00</b> 305 / 5,45
<b>SB99T-4,4</b> 01599440	<b>cm. 440x 200x 90h</b>				<b>6.121,00</b> 336 / 5,99
<b>SB99T-4,8</b> 01599480	<b>cm. 480x 200x 90h</b>				<b>6.413,00</b> 360 / 6,52
<b>SB99T-5,2</b> 01599520	<b>cm. 520x 200x 90h</b>				<b>6.706,00</b> 391 / 7,05
<b>SB99T-5,6</b> 01599560	<b>cm. 560x 200x 90h</b>				<b>6.998,00</b> 415 / 7,58
<b>SB99T-6,0</b> 01599600	<b>cm. 600x 200x 90h</b>				<b>7.290,00</b> 440 / 8,11
<b>SB70T-2,0</b> 01507200	<b>STRUTTURA SBALZO 1 LATO SERIE 70T, 1 PIEDE PER FISSAGGIO A TERRA</b> EN CANTILEVER STRUCTURE 1 side S70T, 1 foot for ground fixing • DE BRÜCKENSTRUKTURE 1 seite S70T, 1 steher für bodenverankerung • FR STRUCTURE SUSPENDUES 1 coté S70T, 1 pied pour le fixage au sol • ES ESTRUCTURA SUSPENDIDA 1 lado S70T, 1 pata para fijacion al suelo <b>cm. 200x 93,8x 90h</b>				<b>2.984,00</b> 110 / 1,32
<b>SB70T-2,4</b> 01507240	<b>cm. 240x 93,8x 90h</b>				<b>3.204,00</b> 120 / 1,58
<b>SB70T-2,8</b> 01507280	<b>STRUTTURA SBALZO 1 LATO SERIE 70T, 2 PIEDI PER FISSAGGIO A TERRA</b> EN CANTILEVER STRUCTURE 1 side S70T, 2 feet for ground fixing • DE BRÜCKENSTRUKTURE 1 seite S70T, 2 stehern für bodenverankerung • FR STRUCTURE SUSPENDUES 1 coté S70T, 2 pieds pour le fixage au sol • ES ESTRUCTURA SUSPENDIDA 1 lado S70T, 2 patas para fijacion al suelo <b>cm. 280x 93,8x 90h</b>				<b>4.534,00</b> 191 / 1,83
<b>SB70T-3,2</b> 01507320	<b>cm. 320x 93,8x 90h</b>				<b>4.753,00</b> 217 / 2,08
<b>SB70T-3,6</b> 01507360	<b>cm. 360x 93,8x 90h</b>				<b>4.973,00</b> 238 / 2,33

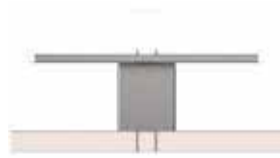

# STRUTTURE SBALZO 1 LATO S70

MOD. COD.	DESCRIZIONE/DESCRIPTION/BEZEICHNUNG/DESCRIPTION/DESCRIPCIÓN DIMENSIONI/DIMENSIONS/ABMESSUNGEN/DIMENSIONS/DIMENSIONES	POTENZA/POWER/LEISTUNG/PUISSANCE/POTENCIA VOLTAGGIO/VOLTAGE/SPANNUNG/VOLTAGE/VOLTAJE	↓ kW kcal/h	↑ kW V~ Hz	PREZZO/PRICE PREIS/PRIX/PRECIO € KG / M <sup>3</sup>
<b>SB70T-4,0</b> 01507400	<b>cm. 400x 93,8x 90h</b>				<b>5.192,00</b> 259 / 2,58
<b>SB70T-4,4</b> 01507440	<b>cm. 440x 93,8x 90h</b>				<b>5.411,00</b> 285 / 2,84
<b>SB70T-4,8</b> 01507480	<b>cm. 480x 93,8x 90h</b>				<b>5.631,00</b> 306 / 3,09
<b>SB70T-5,2</b> 01507520	<b>cm. 520x 93,8x 90h</b>				<b>5.851,00</b> 332 / 3,34
<b>SB70T-5,6</b> 01507560	<b>cm. 560x 93,8x 90h</b>				<b>6.071,00</b> 353 / 3,59
<b>SB70T-6,0</b> 01507600	<b>cm. 600x 93,8x 90h</b>				<b>6.290,00</b> 374 / 3,84
<b>SB77T-2,0</b> 01577200	<b>STRUTTURA SBALZO 2 LATI SERIE 70T, 1 PIEDE PER FISSAGGIO A TERRA</b> EN CANTILEVER STRUCTURE 2 sides S70T, 1 foot for ground fixing • DE BRÜCKENSTRUKTURE 2 seiten S70T, 1 steher für bodenverankerung • FR STRUCTURE SUSPENDUES 2 cotés S70T, 1 pied pour le fixage au sol • ES ESTRUCTURA SUSPENDIDA 2 lados S70T, 1 pata para fijacion al suelo <b>cm. 200x 160x 90h</b>				<b>3.298,00</b> 130 / 2,21
<b>SB77T-2,4</b> 01577240	<b>cm. 240x 160x 90h</b>				<b>3.590,00</b> 143 / 2,63
<b>SB77T-2,8</b> 01577280	<b>STRUTTURA SBALZO 2 LATI SERIE 70T, 2 PIEDI PER FISSAGGIO A TERRA</b> EN CANTILEVER STRUCTURE 2 sides S70T, 2 feet for ground fixing • DE BRÜCKENSTRUKTURE 2 seiten S70T, 2 stehern für bodenverankerung • FR STRUCTURE SUSPENDUES 2 cotés S70T, 2 pieds pour le fixage au sol • ES ESTRUCTURA SUSPENDIDA 2 lados S70T, 2 patas para fijacion al suelo <b>cm. 280x 160x 90h</b>				<b>4.953,00</b> 218 / 3,05
<b>SB77T-3,2</b> 01577320	<b>cm. 320x 160x 90h</b>				<b>5.246,00</b> 248 / 3,47
<b>SB77T-3,6</b> 01577360	<b>cm. 360x 160x 90h</b>				<b>5.538,00</b> 272 / 3,89
<b>SB77T-4,0</b> 01577400	<b>cm. 400x 160x 90h</b>				<b>5.830,00</b> 296 / 4,31
<b>SB77T-4,4</b> 01577440	<b>cm. 440x 160x 90h</b>				<b>6.121,00</b> 326 / 4,73
<b>SB77T-4,8</b> 01577480	<b>cm. 480x 160x 90h</b>				<b>6.413,00</b> 350 / 5,15
<b>SB77T-5,2</b> 01577520	<b>cm. 520x 160x 90h</b>				<b>6.706,00</b> 380 / 5,57
<b>SB77T-5,6</b> 01577560	<b>cm. 560x 160x 90h</b>				<b>6.998,00</b> 404 / 5,99
<b>SB77T-6,0</b> 01577600	<b>cm. 600x 160x 90h</b>				<b>7.290,00</b> 428 / 6,41

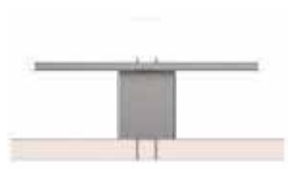

# STRUTTURE SBALZO 2 LATI S90 E 70



MOD. \_\_\_\_\_  
COD. \_\_\_\_\_

DESCRIZIONE/DESCRIPTION/BEZEICHNUNG/DESCRIPTION/DESCRIPCIÓN  
DIMENSIONI/DIMENSIONS/ABMESSUNGEN/DIMENSIONS/DIMENSIONES

POTENZA/POWER/LEISTUNG/PUISSANCE/POTENCIA  
VOLTAGGIO/VOLTAGE/SPANNUNG/VOLTAGE/VOLTAJE

↓ kW kcal/h  
↑ kw V~ Hz

PREZZO/PRICE €  
PREIS/PRIX/PRECIO €  
KG / M<sup>3</sup>

<b>SB79T-2,0</b> 01579200	<b>STRUTTURA SBALZO 2 LATI SERIE 70T/90T, 1 PIEDE PER FISSAGGIO A TERRA</b> <b>EN</b> CANTILEVER STRUCTURE 2 sides S70T/90T, 1 foot for ground fixing • <b>DE</b> BRÜCKENSTRUKTURE 2 seiten S70T/90T, 1 steher für bodenverankerung • <b>FR</b> STRUCTURE SUSPENDUES 2 cotés S70T/90T, 1 pied pour le fixage au sol • <b>ES</b> ESTRUCTURA SUSPENDIDA 2 lados S70T/90T, 1 pata para fijacion al suelo <b>cm. 200x 180x 90h</b>		<b>3.298,00</b> 133 / 2,50
<b>SB79T-2,4</b> 01579240	<b>cm. 240x 180x 90h</b>		<b>3.590,00</b> 146 / 2,98
<b>SB79T-2,8</b> 01579280	<b>STRUTTURA SBALZO 2 LATI SERIE 70T/90T, 2 PIEDI PER FISSAGGIO A TERRA</b> <b>EN</b> CANTILEVER STRUCTURE 2 sides S70T/90T, 2 feet for ground fixing • <b>DE</b> BRÜCKENSTRUKTURE 2 seiten S70T/90T, 2 stehern für bodenverankerung • <b>FR</b> STRUCTURE SUSPENDUES 2 cotés S70T/90T, 2 pieds pour le fixage au sol • <b>ES</b> ESTRUCTURA SUSPENDIDA 2 lados S70T/90T, 2 patas para fijacion al suelo <b>cm. 280x 180x 90h</b>		<b>4.953,00</b> 222 / 3,45
<b>SB79T-3,2</b> 01579320	<b>cm. 320x 180x 90h</b>		<b>5.246,00</b> 253 / 3,93
<b>SB79T-3,6</b> 01579360	<b>cm. 360x 180x 90h</b>		<b>5.538,00</b> 277 / 4,40
<b>SB79T-4,0</b> 01579400	<b>cm. 400x 180x 90h</b>		<b>5.830,00</b> 301 / 4,88
<b>SB79T-4,4</b> 01579440	<b>cm. 440x 180x 90h</b>		<b>6.121,00</b> 331 / 5,36
<b>SB79T-4,8</b> 01579480	<b>cm. 480x 180x 90h</b>		<b>6.413,00</b> 355 / 5,83
<b>SB79T-5,2</b> 01579520	<b>cm. 520x 180x 90h</b>		<b>6.706,00</b> 386 / 6,31
<b>SB79T-5,6</b> 01579560	<b>cm. 560x 180x 90h</b>		<b>6.998,00</b> 410 / 6,78
<b>SB79T-6,0</b> 01579600	<b>cm. 600x 180x 90h</b>		<b>7.290,00</b> 434 / 7,26
<b>SB90T-2,8A</b> 01509281	<b>STRUTTURA SBALZO 1 LATO SERIE 90T, 2 PIEDI AUTOPORTANTI</b> <b>EN</b> CANTILEVER STRUCTURE 1 side S90T, 2 self-supporting feet • <b>DE</b> BRÜCKENSTRUKTURE 1 seite S90T, 2 stehern für selbsttragende Struktur • <b>FR</b> STRUCTURE SUSPENDUES 1 coté S90T, 2 pieds autoportantes • <b>ES</b> ESTRUCTURA SUSPENDIDA 1 lado S90T, 2 patas autoportantes <b>cm. 280x113,8x 90h</b>		<b>5.484,00</b> 194 / 2,23
<b>SB90T-3,2A</b> 01509321	<b>cm. 320x113,8x 90h</b>		<b>5.703,00</b> 221 / 2,54
<b>SB90T-3,6A</b> 01509361	<b>cm. 360x113,8x 90h</b>		<b>5.923,00</b> 242 / 2,85



# STRUTTURE SBALZO 1 LATO S90 AUTOPORTANTI

MOD. COD.	DESCRIZIONE/DESCRIPTION/BEZEICHNUNG/DESCRIPTION/DESCRIPCIÓN DIMENSIONI/DIMENSIONS/ABMESSUNGEN/DIMENSIONS/DIMENSIONES	POTENZA/POWER/LEISTUNG/PUISSANCE/POTENCIA VOLTAGGIO/VOLTAGE/SPANNUNG/VOLTAGE/VOLTAJE	$\frac{kW}{kcal/h}$ $\frac{V}{Hz}$	PREZZO/PRICE PREIS/PRIX/PRECIO € KG / M <sup>3</sup>
SB90T-4,0A 01509401	cm. 400x113,8x 90h			6.142,00 263 / 3,16
SB90T-4,4A 01509441	cm. 440x113,8x 90h			6.362,00 290 / 3,47
SB90T-4,8A 01509481	cm. 480x113,8x 90h			6.581,00 311 / 3,77
SB90T-5,2A 01509521	cm. 520x113,8x 90h			6.801,00 338 / 4,08
SB90T-5,6A 01509561	cm. 560x113,8x 90h			7.021,00 359 / 4,39
SB90T-6,0A 01509601	cm. 600x113,8x 90h			7.240,00 380 / 4,70



SB99T-2,8A 01599281	<b>STRUTTURA SBALZO 2 LATI SERIE 90T, 2 PIEDI AUTOPORTANTI</b> EN CANTILEVER STRUCTURE 2 sides S90T, 2 self-supporting feet • DE BRÜCKENSTRUKTURE 2 seiten S90T, 2 stehern für selbsttragende Struktur • FR STRUCTURE SUSPENDUES 2 cotés S90T, 2 pieds autoportantes • ES ESTRUCTURA SUSPENDIDA 2 lados S90T, 2 patas autoportantes cm. 280x 200x 90h			6.049,00 226 / 3,86
SB99T-3,2A 01599321	cm. 320x 200x 90h			6.342,00 257 / 4,39
SB99T-3,6A 01599361	cm. 360x 200x 90h			6.634,00 281 / 4,92
SB99T-4,0A 01599401	cm. 400x 200x 90h			6.926,00 305 / 5,45
SB99T-4,4A 01599441	cm. 440x 200x 90h			7.218,00 336 / 5,99
SB99T-4,8A 01599481	cm. 480x 200x 90h			7.509,00 360 / 6,52
SB99T-5,2A 01599521	cm. 520x 200x 90h			7.802,00 391 / 7,05
SB99T-5,6A 01599561	cm. 560x 200x 90h			8.094,00 415 / 7,58
SB99T-6,0A 01599601	cm. 600x 200x 90h			8.386,00 440 / 8,11



SB70T-2,8A 01507281	<b>STRUTTURA SBALZO 1 LATO SERIE 70T, 2 PIEDI AUTOPORTANTI</b> EN CANTILEVER STRUCTURE 1 side S70T, 2 self-supporting feet • DE BRÜCKENSTRUKTURE 1 seite S70T, 2 stehern für selbsttragende Struktur • FR STRUCTURE SUSPENDUES 1 coté S70T, 2 pieds autoportantes • ES ESTRUCTURA SUSPENDIDA 1 lado S70T, 2 patas autoportantes cm. 280x 93,8x 90h			5.484,00 191 / 1,83
------------------------	--	--	--	------------------------



# STRUTTURE SBALZO 1 LATO S70 AUTOPORTANTI

MOD. COD.	DESCRIZIONE/DESCRIPTION/BEZEICHNUNG/DESCRIPTION/DESCRIPCIÓN DIMENSIONI/DIMENSIONS/ABMESSUNGEN/DIMENSIONS/DIMENSIONES	POTENZA/POWER/LEISTUNG/PUISSANCE/POTENCIA VOLTAGGIO/VOLTAGE/SPANNUNG/VOLTAGE/VOLTAJE	$\frac{kW}{kcal/h}$ $\frac{V}{Hz}$	PREZZO/PRICE PREIS/PRIX/PRECIO €/M <sup>3</sup>
<b>SB70T-3,2A</b> 01507321	cm. <b>320x 93,8x 90h</b>			<b>5.703,00</b> 217 / 2,08
<b>SB70T-3,6A</b> 01507361	cm. <b>360x 93,8x 90h</b>			<b>5.923,00</b> 238 / 2,33
<b>SB70T-4,0A</b> 01507401	cm. <b>400x 93,8x 90h</b>			<b>6.142,00</b> 259 / 2,58
<b>SB70T-4,4A</b> 01507441	cm. <b>440x 93,8x 90h</b>			<b>6.362,00</b> 285 / 2,84
<b>SB70T-4,8A</b> 01507481	cm. <b>480x 93,8x 90h</b>			<b>6.581,00</b> 306 / 3,09
<b>SB70T-5,2A</b> 01507521	cm. <b>520x 93,8x 90h</b>			<b>6.801,00</b> 332 / 3,34
<b>SB70T-5,6A</b> 01507561	cm. <b>560x 93,8x 90h</b>			<b>7.021,00</b> 353 / 3,59
<b>SB70T-6,0A</b> 01507601	cm. <b>600x 93,8x 90h</b>			<b>7.240,00</b> 374 / 3,84
<b>SB77T-2,8A</b> 01577281	<b>STRUTTURA SBALZO 2 LATI SERIE 70T, 2 PIEDI AUTOPORTANTI</b> EN CANTILEVER STRUCTURE 2 sides S70T, 2 self-supporting feet • DE BRÜCKENSTRUKTURE 2 seiten S70T, 2 stehern für selbsttragende Struktur • FR STRUCTURE SUSPENDUES 2 cotés S70T, 2 pieds autoportantes • ES ESTRUCTURA SUSPENDIDA 2 lados S70T, 2 patas autoportantes cm. <b>280x 160x 90h</b>			<b>6.049,00</b> 218 / 3,05
<b>SB77T-3,2A</b> 01577321	cm. <b>320x 160x 90h</b>			<b>6.342,00</b> 248 / 3,47
<b>SB77T-3,6A</b> 01577361	cm. <b>360x 160x 90h</b>			<b>6.634,00</b> 272 / 3,89
<b>SB77T-4,0A</b> 01577401	cm. <b>400x 160x 90h</b>			<b>6.926,00</b> 296 / 4,31
<b>SB77T-4,4A</b> 01577441	cm. <b>440x 160x 90h</b>			<b>7.218,00</b> 326 / 4,73
<b>SB77T-4,8A</b> 01577481	cm. <b>480x 160x 90h</b>			<b>7.509,00</b> 350 / 5,15
<b>SB77T-5,2A</b> 01577521	cm. <b>520x 160x 90h</b>			<b>7.802,00</b> 380 / 5,57
<b>SB77T-5,6A</b> 01577561	cm. <b>560x 160x 90h</b>			<b>8.094,00</b> 404 / 5,99
<b>SB77T-6,0A</b> 01577601	cm. <b>600x 160x 90h</b>			<b>8.386,00</b> 428 / 6,41



# STRUTTURE SBALZO 2 LATI S90 E 70 AUTOPORTANTI

MOD. \_\_\_\_\_  
COD. \_\_\_\_\_

DESCRIZIONE/DESCRIPTION/BEZEICHNUNG/DESCRIPTION/DESCRIPCIÓN  
DIMENSIONI/DIMENSIONS/ABMESSUNGEN/DIMENSIONS/DIMENSIONES

POTENZA/POWER/LEISTUNG/PUISSANCE/POTENCIA  
VOLTAGGIO/VOLTAGE/SPANNUNG/VOLTAGE/VOLTAJE

↓ kW kcal/h  
↑ kw V~ Hz

PREZZO/PRICE €  
PREIS/PRIX/PRECIO €  
KG / M<sup>3</sup>

**SB79T-2,8A** STRUTTURA SBALZO 2 LATI SERIE 70T/90T, 2 PIEDI AUTOPORTANTI

01579281

EN CANTILEVER STRUCTURE 2 sides S70T/90T, 2 self-supporting feet • DE BRÜCKENSTRUKTURE 2 seiten S70T/90T, 2 stehern für selbsttragende Struktur • FR STRUCTURE SUSPENDUES 2 cotés S70T/90T, 2 pieds autoportantes • ES ESTRUCTURA SUSPENDIDA 2 lados S70T/90T, 2 patas autoportantes  
cm. **280x 180x 90h**



**6.049,00**  
222 / 3,45

**SB79T-3,2A** cm. **320x 180x 90h**

01579321

**6.342,00**  
253 / 3,93

**SB79T-3,6A** cm. **360x 180x 90h**

01579361

**6.634,00**  
277 / 4,40

**SB79T-4,0A** cm. **400x 180x 90h**

01579401

**6.926,00**  
301 / 4,88

**SB79T-4,4A** cm. **440x 180x 90h**

01579441

**7.218,00**  
331 / 5,36

**SB79T-4,8A** cm. **480x 180x 90h**

01579481

**7.509,00**  
355 / 5,83

**SB79T-5,2A** cm. **520x 180x 90h**

01579521

**7.802,00**  
386 / 6,31

**SB79T-5,6A** cm. **560x 180x 90h**

01579561

**8.094,00**  
410 / 6,78

**SB79T-6,0A** cm. **600x 180x 90h**

01579601

**8.386,00**  
434 / 7,26

**SOVMOB** SOVRAPPREZZO PER MONTAGGIO DI UN APPARECCHIO A MOBILE. ATTENZIONE: IN CASO DI MONTAGGIO SU STRUTTURE DA 2,0/2,4 MT., QUEST'ULTIME SARANNO PRODOTTE CON 2 PIEDI

EN OVERPRICE FOR ASSEMBLY OF A STAND UNIT. ATTENTION: IN CASE OF MOUNTING OVER STRUCTURE FOR 2,0/2,4 mt, THE LATTER WILL BE PRODUCED WITH TWO FEET. • DE PREISERHORUNG FÜR DIE MONTAGE VON EINE STAND GERAT. ACHTUNG: FÜR DEN EINBAU AUF STRUKTUREN VON 2,0/2,4 Meter, WERDEN DIESE MIT 2 FUSSE GELIEFERT. • FR AUGMENTATION DE PRIX POUR L'ASSEMBLAGE D'UN APPAREIL SUR PLACARD. ATTENTION: EN CAS DE MONTAGE SUR STRUCTURES DE 2,0 ET 2,4 mt., CES STRUCTURES SERONT PRODUITE AVEC 2 PIEDS. • ES INCREMENTO DE PRECIOS POR LE MONTAJE DE UN APPARATO SOBRE UN MEUBLE. ATENCION: EN CASO DE MONTAJE SU ESTRUCTURAS DE MEDIDA 2,0m Y 2,4m, ESAS SERAN DE 2 PATAS



**226,00**  
/

**CORRIMANO** CORRIMANO

EN HANDRAIL • DE HAND LAUF • FR MAIN COURANTE • ES PASAMANO  
€/m



**315,00**  
/

# TESTATE 1 LATO S90

MOD. \_\_\_\_\_  
COD. \_\_\_\_\_

DESCRIZIONE/DESCRIPTION/BEZEICHNUNG/DESCRIPTION/DESCRIPCIÓN  
DIMENSIONI/DIMENSIONS/ABMESSUNGEN/DIMENSIONS/DIMENSIONES

POTENZA/POWER/LEISTUNG/PUISSANCE/POTENCIA  
VOLTAGGIO/VOLTAGE/SPANNUNG/VOLTAGE/VOLTAJE

$\frac{kW}{kcal/h}$   $\frac{kw}{V\sim}$   
Hz

PREZZO/PRICE €  
PREIS/PRIX/PRECIO €  
KG / M<sup>3</sup>

**SB90-FDX**  
01609000

**TESTATA 1 LATO SERIE 90 DX**  
**EN** Head 1 side S90 DX • **DE** Abschluss element 1 seite S90 DX • **FR** Element de jonction 1 coté S90 DX • **ES** Embellecedor 1 lado S90 DX

**328,00**  
13.4 / 0,02

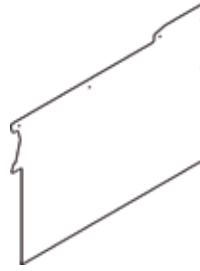

**SB90-FPDX**  
01609010

**TESTATA 1 LATO SERIE 90 DX CON PIANETTO**  
**EN** Head 1 side S90 DX with shelf • **DE** Abschluss element 1 seite S90 DX mit ablage • **FR** Element de jonction 1 coté S90 DX avec etagere • **ES** Embellecedor 1 lado S90 DX con estante  
**cm. 20**

**593,00**  
18.8 / 0,38

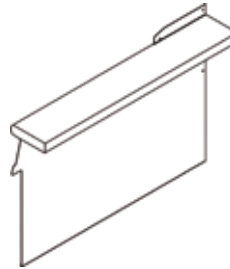

**SB90-FSX**  
01609001

**TESTATA 1 LATO SERIE 90 SX**  
**EN** Head 1 side S90 SX • **DE** Abschluss element 1 seite S90 SX • **FR** Element de jonction 1 coté S90 SX • **ES** Embellecedor 1 lado S90 SX

**328,00**  
13.4 / 0,02

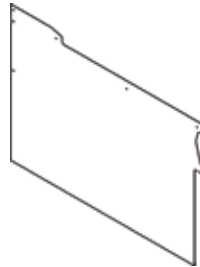

**SB90-FPSX**  
01609011

**TESTATA 1 LATO SERIE 90 SX CON PIANETTO**  
**EN** Head 1 side S90 SX with shelf • **DE** Abschluss element 1 seite S90 SX mit ablage • **FR** Element de jonction 1 coté S90 SX avec etagere • **ES** Embellecedor 1 lado S90 SX con estante  
**cm. 20**

**593,00**  
18.8 / 0,38

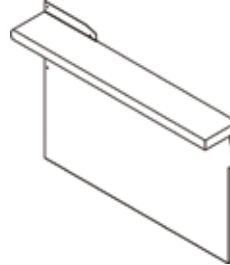

**SB99-F**  
01699002

**TESTATA 2 LATI SERIE 90**  
**EN** Head 2 sides S90 • **DE** Abschluss element seiten S90 • **FR** Element de jonction 2 cotés S90 • **ES** Embellecedor 2 lados S90

**490,00**  
23.7 / 0,04

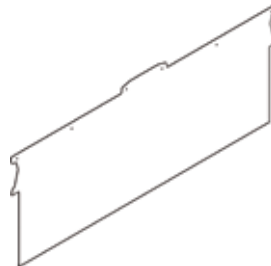

**SB99-FP**  
01699012

**TESTATA 2 LATI SERIE 90 CON PIANETTO**  
**EN** Head 2 sides S90 with shelf • **DE** Abschluss element seiten S90 mit ablage • **FR** Element de jonction 2 cotés S90 avec etagere • **ES** Embellecedor 2 lados S90 con estante  
**cm. 20**

**791,00**  
33.3 / 0,66

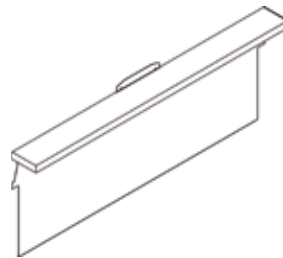

# TESTATE 1 LATO S90

MOD. \_\_\_\_\_  
COD. \_\_\_\_\_

DESCRIZIONE/DESCRIPTION/BEZEICHNUNG/DESCRIPTION/DESCRIPCIÓN  
DIMENSIONI/DIMENSIONS/ABMESSUNGEN/DIMENSIONS/DIMENSIONES

POTENZA/POWER/LEISTUNG/PUISSANCE/POTENCIA  
VOLTAGGIO/VOLTAGE/SPANNUNG/VOLTAGE/VOLTAJE

$\frac{kW}{kcal/h}$   $\frac{V}{Hz}$

PREZZO/PRICE €  
PREIS/PRIX/PRECIO €  
KG / M<sup>3</sup>

**SB90T-FDX** TESTATA 1 LATO SERIE 90TOP DX  
01709000 **EN** Head 1 side S90TOP DX • **DE** Abschluss element  
1 seite S90TOP DX • **FR** Element de jonction 1 coté  
S90TOP DX • **ES** Embellecedor 1 lado S90TOP DX

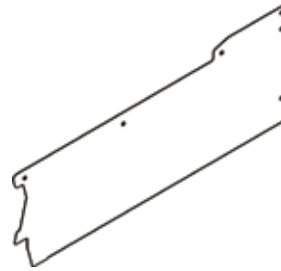

**225,00**  
5.1 / 0,01

**SB90T-FPDX** TESTATA 1 LATO SERIE 90TOP DX CON  
01709010 **PIANETTO**  
**EN** Head 1 side S90TOP DX with shelf • **DE** Abschluss  
element 1 seite S90TOP DX mit ablage • **FR** Element  
de jonction 1 coté S90TOP DX avec etagere • **ES**  
Embellecedor 1 lado S90TOP DX con estante  
**cm. 20**

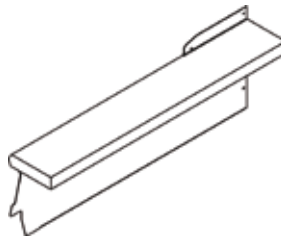

**490,00**  
10.5 / 0,21

**SB90T-FSX** TESTATA 1 LATO SERIE 90TOP SX  
01709001 **EN** Head 1 side S90TOP SX • **DE** Abschluss element  
1 seite S90TOP SX • **FR** Element de jonction 1 coté  
S90TOP SX • **ES** Embellecedor 1 lado S90TOP SX

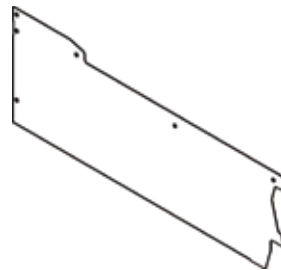

**225,00**  
5.2 / 0,01

**SB90T-FPSX** TESTATA 1 LATO SERIE 90TOP SX CON  
01709011 **PIANETTO**  
**EN** Head 1 side S90TOP SX with shelf • **DE** Abschluss  
element 1 seite S90TOP SX mit ablage • **FR** Element  
de jonction 1 coté S90TOP SX avec etagere • **ES**  
Embellecedor 1 lado S90TOP SX con estante  
**cm. 20**

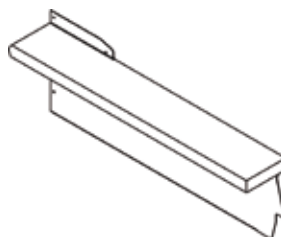

**490,00**  
10.7 / 0,21

**SB99T-F** TESTATA 2 LATI SERIE 90TOP  
01799002 **EN** Head 2 sides S90TOP • **DE** Abschluss element  
seiten S90TOP • **FR** Element de jonction 2 cotés  
S90TOP • **ES** Embellecedor 2 lados S90TOP

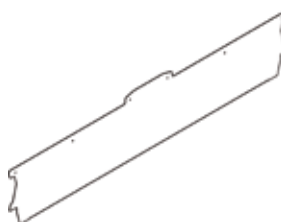

**301,00**  
9.3 / 0,02

**SB99T-FP** TESTATA 2 LATI SERIE 90TOP CON PIANETTO  
01799012 **EN** Head 2 sides S90TOP with shelf • **DE** Abschluss  
element seiten S90TOP mit ablage • **FR** Element  
de jonction 2 cotés S90TOP avec etagere • **ES**  
Embellecedor 2 lados S90TOP con estante  
**cm. 20**

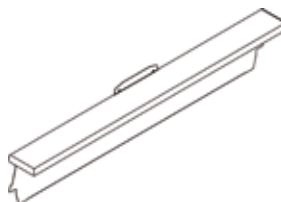

**603,00**  
18.9 / 0,37



# TESTATE 1 LATO S70

MOD. \_\_\_\_\_  
COD. \_\_\_\_\_

DESCRIZIONE/DESCRIPTION/BEZEICHNUNG/DESCRIPTION/DESCRIPCIÓN  
DIMENSIONI/DIMENSIONS/ABMESSUNGEN/DIMENSIONS/DIMENSIONES

POTENZA/POWER/LEISTUNG/PUISSANCE/POTENCIA  
VOLTAGGIO/VOLTAGE/SPANNUNG/VOLTAGE/VOLTAJE

↓ kW kcal/h  
↑ kw V~ Hz

PREZZO/PRICE €  
PREIS/PRIX/PRECIO €  
KG / M<sup>3</sup>

**SB70-FDX**  
01607000

**TESTATA 1 LATO SERIE 70 DX**  
**EN** Head 1 side S70 DX • **DE** Abschluss element 1 seite S70 DX • **FR** Element de jonction 1 coté S70 DX • **ES** Embellecedor 1 lado S70 DX

**295,00**  
11 / 0,02



**SB70-FPDX**  
01607010

**TESTATA 1 LATO SERIE 70 DX CON PIANETTO**  
**EN** Head 1 side S70 DX with shelf • **DE** Abschluss element 1 seite S70 DX mit ablage • **FR** Element de jonction 1 coté S70 DX avec etagere • **ES** Embellecedor 1 lado S70 DX con estante  
**cm. 20**

**550,00**  
15.5 / 0,32

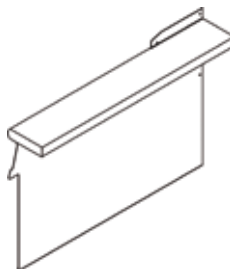

**SB70-FSX**  
01607001

**TESTATA 1 LATO SERIE 70 SX**  
**EN** Head 1 side S70 SX • **DE** Abschluss element 1 seite S70 SX • **FR** Element de jonction 1 coté S70 SX • **ES** Embellecedor 1 lado S70 SX

**295,00**  
11 / 0,02

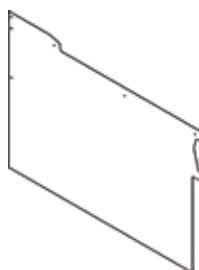

**SB70-FPSX**  
01607011

**TESTATA 1 LATO SERIE 70 SX CON PIANETTO**  
**EN** Head 1 side S70 SX with shelf • **DE** Abschluss element 1 seite S70 SX mit ablage • **FR** Element de jonction 1 coté S70 SX avec etagere • **ES** Embellecedor 1 lado S70 SX con estante  
**cm. 20**

**550,00**  
15.5 / 0,32

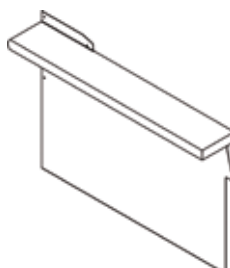

**SB77-F**  
01677002

**TESTATA 2 LATI SERIE 70**  
**EN** Head 2 sides S70 • **DE** Abschluss element seiten S70 • **FR** Element de jonction 2 cotés S70 • **ES** Embellecedor 2 lados S70

**414,00**  
18.9 / 0,04

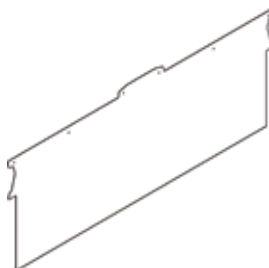

**SB77-FP**  
01677012

**TESTATA 2 LATI SERIE 70 CON PIANETTO**  
**EN** Head 2 sides S70 with shelf • **DE** Abschluss element seiten S70 mit ablage • **FR** Element de jonction 2 cotés S70 avec etagere • **ES** Embellecedor 2 lados S70 con estante  
**cm. 20**

**698,00**  
26.6 / 0,54

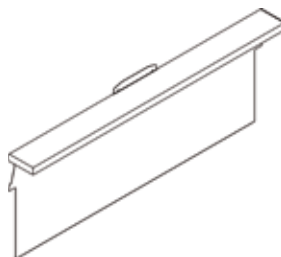

# TESTATE 1 LATO S70

MOD. \_\_\_\_\_  
COD. \_\_\_\_\_

DESCRIZIONE/DESCRIPTION/BEZEICHNUNG/DESCRIPTION/DESCRIPCIÓN  
DIMENSIONI/DIMENSIONS/ABMESSUNGEN/DIMENSIONS/DIMENSIONES

POTENZA/POWER/LEISTUNG/PUISSANCE/POTENCIA  
VOLTAGGIO/VOLTAGE/SPANNUNG/VOLTAGE/VOLTAJE

$\frac{kW}{kcal/h}$   $\frac{V}{Hz}$

PREZZO/PRICE €  
PREIS/PRIX/PRECIO €  
KG / M<sup>3</sup>

**SB70T-FDX** TESTATA 1 LATO SERIE 70TOP DX  
01707000 **EN** Head 1 side S70TOP DX • **DE** Abschluss element  
1 seite S70TOP DX • **FR** Element de jonction 1 coté  
S70TOP DX • **ES** Embellecedor 1 lado S70TOP DX

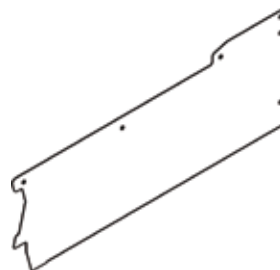

**209,00**  
4.2 / 0,01

**SB70T-FPDX** TESTATA 1 LATO SERIE 70TOP DX CON  
01707010 **PIANETTO**  
**EN** Head 1 side S70TOP DX with shelf • **DE** Abschluss  
element 1 seite S70TOP DX mit ablage • **FR** Element  
de jonction 1 coté S70TOP DX avec etagere • **ES**  
Embellecedor 1 lado S70TOP DX con estante  
**cm. 20**

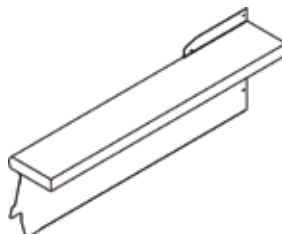

**461,00**  
8.6 / 0,18

**SB70T-FSX** TESTATA 1 LATO SERIE 70TOP SX  
01707001 **EN** Head 1 side S70TOP SX • **DE** Abschluss element  
1 seite S70TOP SX • **FR** Element de jonction 1 coté  
S70TOP SX • **ES** Embellecedor 1 lado S70TOP SX

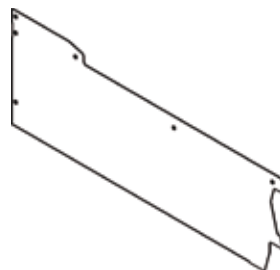

**209,00**  
4.3 / 0,01

**SB70T-FPSX** TESTATA 1 LATO SERIE 70TOP SX CON  
01707011 **PIANETTO**  
**EN** Head 1 side S70TOP SX with shelf • **DE** Abschluss  
element 1 seite S70TOP SX mit ablage • **FR** Element  
de jonction 1 coté S70TOP SX avec etagere • **ES**  
Embellecedor 1 lado S70TOP SX con estante  
**cm. 20**

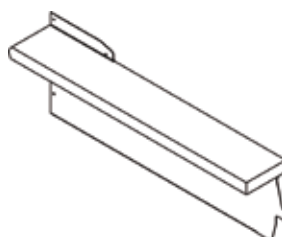

**461,00**  
8.8 / 0,18

**SB77T-F** TESTATA 2 LATI SERIE 70TOP  
01777002 **EN** Head 2 sides S70TOP • **DE** Abschluss element  
seiten S70TOP • **FR** Element de jonction 2 cotés  
S70TOP • **ES** Embellecedor 2 lados S70TOP

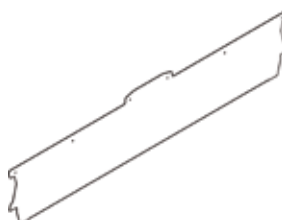

**263,00**  
7.4 / 0,02

**SB77T-FP** TESTATA 2 LATI SERIE 70TOP CON PIANETTO  
01777012 **EN** Head 2 sides S70TOP with shelf • **DE** Abschluss  
element seiten S70TOP mit ablage • **FR** Element  
de jonction 2 cotés S70TOP avec etagere • **ES**  
Embellecedor 2 lados S70TOP con estante  
**cm. 20**

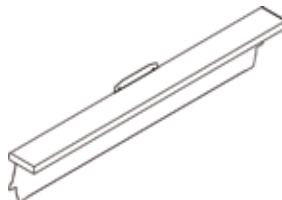

**547,00**  
15.1 / 0,30

# TESTATE 2 LATI S90 E 70

MOD. \_\_\_\_\_  
COD. \_\_\_\_\_

DESCRIZIONE/DESCRIPTION/BEZEICHNUNG/DESCRIPTION/DESCRIPCIÓN  
DIMENSIONI/DIMENSIONS/ABMESSUNGEN/DIMENSIONS/DIMENSIONES

POTENZA/POWER/LEISTUNG/PUISSANCE/POTENCIA  
VOLTAGGIO/VOLTAGE/SPANNUNG/VOLTAGE/VOLTAJE

↓ kW kcal/h  
↗ kW V~ Hz

PREZZO/PRICE €  
PREIS/PRIX/PRECIO €  
KG / M<sup>3</sup>

**SB79-FDX**  
01679000

**TESTATA 2 LATI SERIE 70/90 DX**  
**EN** Head 2 sides S70/S90 DX • **DE** Abschluss element seiten S70/S90 DX • **FR** Element de jonction 2 cotés S70/S90 DX • **ES** Embellecedor 2 lados S70/S90 DX

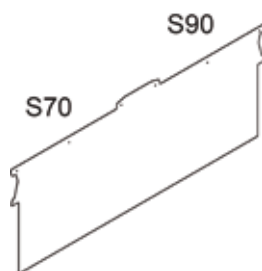

**452,00**  
21.3 / 0,04

**SB79-FPDX**  
01679010

**TESTATA 2 LATI SERIE 70/90 DX CON PIANETTO**  
**EN** Head 2 sides S70/S90 DX with shelf • **DE** Abschluss element seiten S70/S90 DX mit ablage • **FR** Element de jonction 2 cotés S70/S90 DX avec etagere • **ES** Embellecedor 2 lados S70/S90 DX con estante  
**cm. 20**

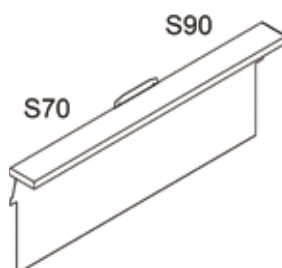

**743,00**  
30 / 0,60

**SB79-FSX**  
01679001

**TESTATA 2 LATI SERIE 70/90 SX**  
**EN** Head 2 sides S70/S90 SX • **DE** Abschluss element seiten S70/S90 SX • **FR** Element de jonction 2 cotés S70/S90 SX • **ES** Embellecedor 2 lados S70/S90 SX

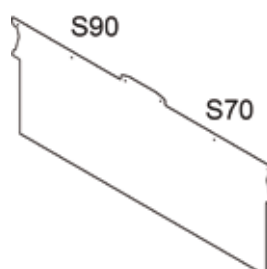

**452,00**  
21.3 / 0,04

**SB79-FPSX**  
01679011

**TESTATA 2 LATI SERIE 70/90 SX CON PIANETTO**  
**EN** Head 2 sides S70/S90 SX with shelf • **DE** Abschluss element seiten S70/S90 SX mit ablage • **FR** Element de jonction 2 cotés S70/S90 SX avec etagere • **ES** Embellecedor 2 lados S70/S90 SX con estante  
**cm. 20**

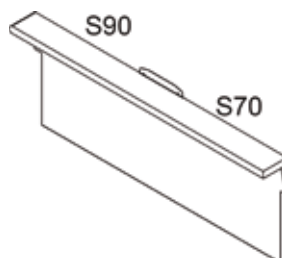

**743,00**  
30 / 0,60

**SB79T-FDX**  
01779000

**TESTATA 2 LATI SERIE 70TOP/90TOP DX**  
**EN** Head 2 sides S70TOP/S90TOP DX • **DE** Abschluss element seiten S70TOP/S90TOP DX • **FR** Element de jonction 2 cotés S70TOP/S90TOP DX • **ES** Embellecedor 2 lados S70TOP/S90TOP DX

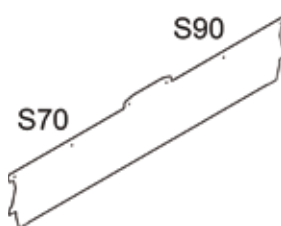

**283,00**  
8.4 / 0,02

**SB79T-FPDX**  
01779010

**TESTATA 2 LATI SERIE 70TOP/90TOP DX CON PIANETTO**  
**EN** Head 2 sides S70TOP/S90TOP DX with shelf • **DE** Abschluss element seiten S70TOP/S90TOP DX mit ablage • **FR** Element de jonction 2 cotés S70TOP/S90TOP DX avec etagere • **ES** Embellecedor 2 lados S70TOP/S90TOP DX con estante  
**cm. 20**

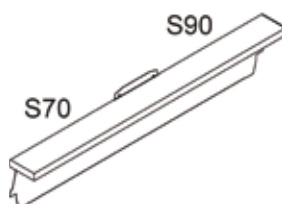

**574,00**  
17 / 0,33

# TESTATE 2 LATI S90 E 70

MOD. \_\_\_\_\_  
COD. \_\_\_\_\_

DESCRIZIONE/DESCRIPTION/BEZEICHNUNG/DESCRIPTION/DESCRIPCIÓN  
DIMENSIONI/DIMENSIONS/ABMESSUNGEN/DIMENSIONS/DIMENSIONES

POTENZA/POWER/LEISTUNG/PUISSANCE/POTENCIA  
VOLTAGGIO/VOLTAGE/SPANNUNG/VOLTAGE/VOLTAJE

↓ kW kcal/h  
↑ kW V~ Hz

PREZZO/PRICE €  
PREIS/PRIX/PRECIO €  
KG / M<sup>3</sup>

**SB79T-FSX** TESTATA 2 LATI SERIE 70TOP/90TOP SX  
01779001 **EN** Head 2 sides S70TOP/S90TOP SX • **DE** Abschluss element seiten S70TOP/S90TOP SX • **FR** Element de jonction 2 cotés S70TOP/S90TOP SX • **ES** Embellecedor 2 lados S70TOP/S90TOP SX

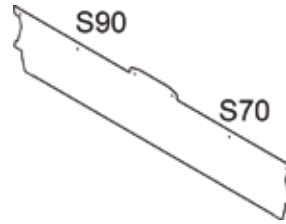

**283,00**  
8.4 / 0,02

**SB79T-FPSX** TESTATA 2 LATI SERIE 70TOP/90TOP SX CON  
01779011 **PIANETTO**  
**EN** Head 2 sides S70TOP/S90TOP SX with shelf • **DE** Abschluss element seiten S70TOP/S90TOP SX mit ablage • **FR** Element de jonction 2 cotés S70TOP/S90TOP SX avec etagere • **ES** Embellecedor 2 lados S70TOP/S90TOP SX con estante  
**cm. 20**

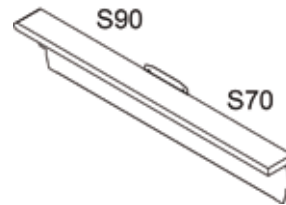

**574,00**  
17 / 0,33

**SB99TM-FDX** TESTATA 2 LATI SERIE 90TOP/90 DX  
01899000 **EN** Head 2 sides S90TOP/S90 DX • **DE** Abschluss element seiten S90TOP/S90 DX • **FR** Element de jonction 2 cotés S90TOP/S90 DX • **ES** Embellecedor 2 lados S90TOP/S90 DX

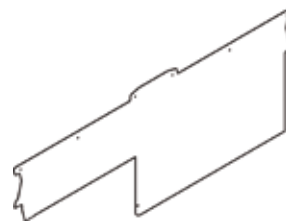

**407,00**  
17.3 / 0,04

**SB99TM-FPD** TESTATA 2 LATI SERIE 90TOP/90 DX CON  
01899010 **PIANETTO**  
**EN** Head 2 sides S90TOP/S90 DX with shelf • **DE** Abschluss element seiten S90TOP/S90 DX mit ablage • **FR** Element de jonction 2 cotés S90TOP/S90 DX avec etagere • **ES** Embellecedor 2 lados S90TOP/S90 DX con estante  
**cm. 20**

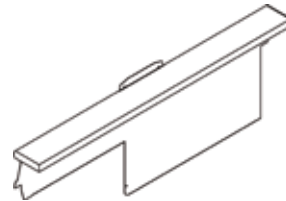

**712,00**  
26.9 / 0,66

**SB99TM-FSX** TESTATA 2 LATI SERIE 90TOP/90 SX  
01899001 **EN** Head 2 sides S90TOP/S90 SX • **DE** Abschluss element seiten S90TOP/S90 SX • **FR** Element de jonction 2 cotés S90TOP/S90 SX • **ES** Embellecedor 2 lados S90TOP/S90 SX

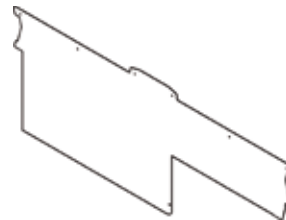

**407,00**  
17.3 / 0,04

**SB99TM-FPSX** TESTATA 2 LATI SERIE 90TOP/90 SX CON  
01899011 **PIANETTO**  
**EN** Head 2 sides S90TOP/S90 SX with shelf • **DE** Abschluss element seiten S90TOP/S90 SX mit ablage • **FR** Element de jonction 2 cotés S90TOP/S90 SX avec etagere • **ES** Embellecedor 2 lados S90TOP/S90 SX con estante  
**cm. 20**

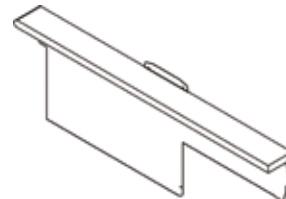

**712,00**  
26.9 / 0,66

**SB77TM-FDX** TESTATA 2 LATI SERIE 70TOP/70 DX  
01877000 **EN** Head 2 sides S70TOP/S70 DX • **DE** Abschluss element seiten S70TOP/S70 DX • **FR** Element de jonction 2 cotés S70TOP/S70 DX • **ES** Embellecedor 2 lados S70TOP/S70 DX

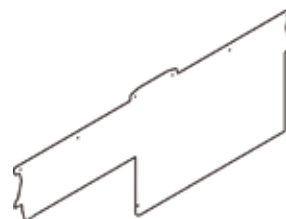

**353,00**  
13.8 / 0,04

# TESTATE 2 LATI S90 E 70

MOD. \_\_\_\_\_  
COD. \_\_\_\_\_

DESCRIZIONE/DESCRIPTION/BEZEICHNUNG/DESCRIPTION/DESCRIPCIÓN  
DIMENSIONI/DIMENSIONS/ABMESSUNGEN/DIMENSIONS/DIMENSIONES

POTENZA/POWER/LEISTUNG/PUISSANCE/POTENCIA  
VOLTAGGIO/VOLTAGE/SPANNUNG/VOLTAGE/VOLTAJE

↓ kW kcal/h    ↗ kW V~ Hz

PREZZO/PRICE €  
PREIS/PRIX/PRECIO €  
KG / M<sup>3</sup>

**SB77TM-FPDX TESTATA 2 LATI SERIE 70TOP/70 DX CON PIANETTO**

01877010

**EN** Head 2 sides S70TOP/S70 DX with shelf • **DE** Abschluss element seiten S70TOP/S70 DX mit ablage  
• **FR** Element de jonction 2 cotés S70TOP/S70 DX avec etagere • **ES** Embellecedor 2 lados S70TOP/S70 DX con estante  
**cm. 20**

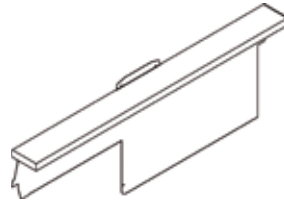

**635,00**  
21.5 / 0,54

**SB77TM-FSX TESTATA 2 LATI SERIE 70TOP/70 SX**

01877001

**EN** Head 2 sides S70TOP/S70 SX • **DE** Abschluss element seiten S70TOP/S70 SX • **FR** Element de jonction 2 cotés S70TOP/S70 SX • **ES** Embellecedor 2 lados S70TOP/S70 SX

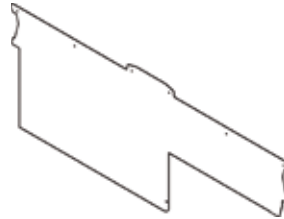

**353,00**  
13.8 / 0,04

**SB77TM-FPSX TESTATA 2 LATI SERIE 70TOP/70 SX CON PIANETTO**

01877011

**EN** Head 2 sides S70TOP/S70 SX with shelf • **DE** Abschluss element seiten S70TOP/S70 SX mit ablage  
• **FR** Element de jonction 2 cotés S70TOP/S70 SX avec etagere • **ES** Embellecedor 2 lados S70TOP/S70 SX con estante  
**cm. 20**

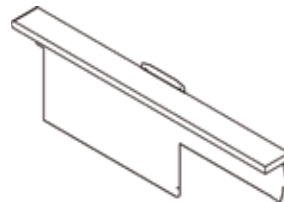

**635,00**  
21.5 / 0,54

**SB79TM-FDX TESTATA 2 LATI SERIE 70TOP/90 DX**

01879000

**EN** Head 2 sides S70TOP/S90 DX • **DE** Abschluss element seiten S70TOP/S90 DX • **FR** Element de jonction 2 cotés S70TOP/S90 DX • **ES** Embellecedor 2 lados S70TOP/S90 DX

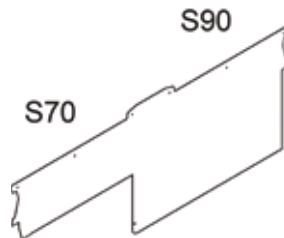

**399,00**  
15.6 / 0,04

**SB79TM-FPDX TESTATA 2 LATI SERIE 70TOP/90 DX CON PIANETTO**

01879010

**EN** Head 2 sides S70TOP/S90 DX with shelf • **DE** Abschluss element seiten S70TOP/S90 DX mit ablage  
• **FR** Element de jonction 2 cotés S70TOP/S90 DX avec etagere • **ES** Embellecedor 2 lados S70TOP/S90 DX con estante  
**cm. 20**

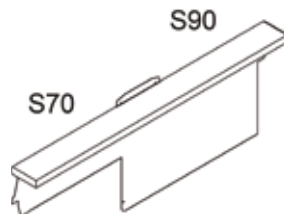

**702,00**  
24.2 / 0,60

**SB79TM-FSX TESTATA 2 LATI SERIE 70TOP/90 SX**

01879001

**EN** Head 2 sides S70TOP/S90 SX • **DE** Abschluss element seiten S70TOP/S90 SX • **FR** Element de jonction 2 cotés S70TOP/S90 SX • **ES** Embellecedor 2 lados S70TOP/S90 SX

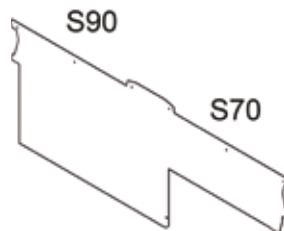

**399,00**  
15.6 / 0,04

**SB79TM-FPSX TESTATA 2 LATI SERIE 70TOP/90 SX CON PIANETTO**

01879011

**EN** Head 2 sides S70TOP/S90 SX with shelf • **DE** Abschluss element seiten S70TOP/S90 SX mit ablage  
• **FR** Element de jonction 2 cotés S70TOP/S90 SX avec etagere • **ES** Embellecedor 2 lados S70TOP/S90 SX con estante  
**cm. 20**

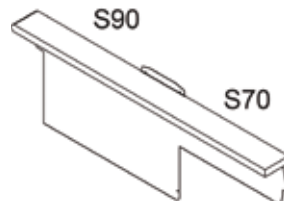

**702,00**  
24.2 / 0,60



# TESTATE 2 LATI S90 E 70

MOD. \_\_\_\_\_  
COD. \_\_\_\_\_

DESCRIZIONE/DESCRIPTION/BEZEICHNUNG/DESCRIPTION/DESCRIPCIÓN  
DIMENSIONI/DIMENSIONS/ABMESSUNGEN/DIMENSIONS/DIMENSIONES

POTENZA/POWER/LEISTUNG/PUISSANCE/POTENCIA  
VOLTAGGIO/VOLTAGE/SPANNUNG/VOLTAGE/VOLTAJE

$\frac{kW}{kcal/h}$   $\frac{V}{Hz}$

PREZZO/PRICE €  
PREIS/PRIX/PRECIO €  
KG / M<sup>3</sup>

**SB97TM-FDX TESTATA 2 LATI SERIE 90TOP/70 DX**  
01897000 **EN** Head 2 sides S90TOP/S70 DX • **DE** Abschluss element seiten S90TOP/S70 DX • **FR** Element de jonction 2 cotés S90TOP/S70 DX • **ES** Embellecedor 2 lados S90TOP/S70 DX

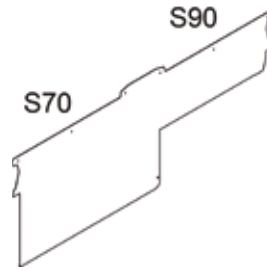

**346,00**  
14.4 / 0,04

**SB97TM-FPDX TESTATA 2 LATI SERIE 90TOP/70 DX CON PIANETTO**  
01897010 **EN** Head 2 sides S90TOP/S70 DX with shelf • **DE** Abschluss element seiten S90TOP/S70 DX mit ablage • **FR** Element de jonction 2 cotés S90TOP/S70 DX avec etagere • **ES** Embellecedor 2 lados S90TOP/S70 DX con estante  
**cm. 20**

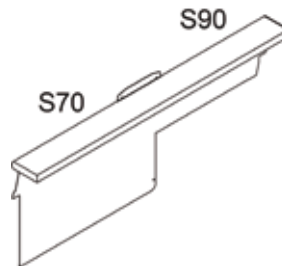

**629,00**  
23 / 0,60

**SB97TM-FSX TESTATA 2 LATI SERIE 90TOP/70 SX**  
01897001 **EN** Head 2 sides S90TOP/S70 SX • **DE** Abschluss element seiten S90TOP/S70 SX • **FR** Element de jonction 2 cotés S90TOP/S70 SX • **ES** Embellecedor 2 lados S90TOP/S70 SX

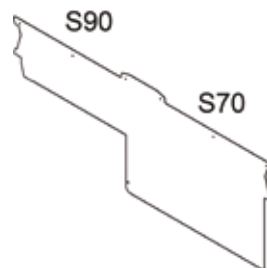

**346,00**  
14.4 / 0,04

**SB97TM-FPSX TESTATA 2 LATI SERIE 90TOP/70 SX CON PIANETTO**  
01897011 **EN** Head 2 sides S90TOP/S70 SX with shelf • **DE** Abschluss element seiten S90TOP/S70 SX mit ablage • **FR** Element de jonction 2 cotés S90TOP/S70 SX avec etagere • **ES** Embellecedor 2 lados S90TOP/S70 SX con estante  
**cm. 20**

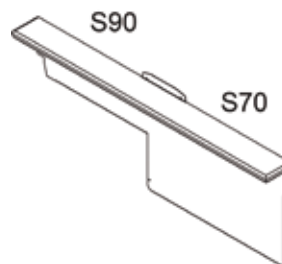

**629,00**  
23 / 0,60



**FMPG-20 + 40280600**



**FMPE-30**



**F1-G**



**FPE-25 + 40280800**

# FRIGGITRICI ELETTRICHE - TOP

MOD. \_\_\_\_\_  
COD. \_\_\_\_\_

DESCRIZIONE/DESCRIPTION/BEZEICHNUNG/DESCRIPTION/DESCRIPCIÓN  
DIMENSIONI/DIMENSIONS/ABMESSUNGEN/DIMENSIONS/DIMENSIONES

POTENZA/POWER/LEISTUNG/PUISSANCE/POTENCIA  
VOLTAGGIO/VOLTAGE/SPANNUNG/VOLTAGE/VOLTAJE

⚡ kW \_\_\_\_\_  
230V~  
50/60 Hz

PREZZO/PRICE €  
PREIS/PRIX/PRECIO €  
KG / M<sup>3</sup>

**FEC-2**  
35010210

**FRIGGITRICE LT. 2 MONOFASE CESTINO  
CM.15X25X9H. - PRODUZIONE PATATE 2  
KG/H**

EN Fryer lts. 2 singlephase - Basket cm. 15x25x9h -  
Production 2 kg/hr • DE Friteuse lt. 2 einphasig - Korb  
cm. 15x25x9h - Pommes frites: 2 kg/h • FR Friteuse lt.  
2 monophasé - Panier cm. 15x25x9h - Production de  
pommes frites 2 Kg/h • ES Freidoras 2 lt. monofásica -  
Cesta cm. 15x25x9h - Producción patatas 2 Kg/h  
**cm. 19x 38x 15h**



⚡ 1,8 kW \_\_\_\_\_ **276,00**  
230V~ \_\_\_\_\_ 5 / 0,03  
50/60 Hz

**FE-04EM**  
35010411

**FRIGGITRICE LT. 4 MONOFASE CESTINO  
CM.13X23X10H - PRODUZIONE PATATE 5  
KG/H**

EN Fryer lts. 4 singlephase - Basket cm. 13x23x10h -  
Production 5 kg/hr • DE Friteuse lt. 4 einphasig - Korb  
cm. 13x23x10h - Pommes frites: 5 kg/h • FR Friteuse lt.  
4 monophasé - Panier cm. 13x23x10h - Production de  
pommes frites 5 Kg/h • ES Freidoras 4 lt. monofásica -  
Cesta cm. 13x23x10h - Producción patatas 5 Kg/h  
**cm. 18x 42x 30h**

⚡ 2,1 kW \_\_\_\_\_ **323,00**  
230V~ \_\_\_\_\_ 9 / 0,04  
50 Hz

**FE-07EM**  
35010710

**FRIGGITRICE LT. 7 MONOFASE CESTINO CM.  
21X23,5X10H - PRODUZIONE PATATE 7 KG/H**

EN Fryer lts. 7 singlephase - Basket cm. 21x23,5x10h  
- Production 7 kg/hr • DE Friteuse lt. 7 einphasig -  
Korb cm. 21x23,5x10h - Pommes frites: 7 kg/h • FR  
Friteuse lt. 7 monophasé - Panier cm. 21x23,5x10h -  
Production de pommes frites 7 Kg/h • ES Freidoras 7  
lt. monofásica - Cesta cm. 21x23,5x10h - Producción  
patatas 7 Kg/h  
**cm. 27x 42x 30h**



⚡ 3 kW \_\_\_\_\_ **374,00**  
230V~ \_\_\_\_\_ 9 / 0,05  
50 Hz

**FE-77EM**  
35020710

**FRIGGITRICE LT. 7+7 MONOFASE 2 CESTINI  
CM. 21X23,5X10H - PRODUZIONE PATATE 14  
KG/H**

EN Fryer lts. 7+7 singlephase - 2 baskets cm.  
21x23,5x10h - Production 14 kg/hr • DE Friteuse lt.  
7+7 einphasig - 2 Korbe cm. 21x23,5x10h - Pommes  
frites: 14 kg/h • FR Friteuse lt. 7+7 monophasé - 2  
Paniers cm. 21x23,5x10h - Production de pommes frites  
14 Kg/h • ES Freidoras 7+7 lt. monofásica - 2 cestas  
cm. 21x23,5x10h - Producción patatas 14 Kg/h  
**cm. 54x 42x 30h**



⚡ 6 kW \_\_\_\_\_ **680,00**  
230V~ \_\_\_\_\_ 16 / 0,10  
50 Hz

**FEM-6**  
35010610

**FRIGGITRICE LT. 6 MONOFASE VASCA CM.  
22X32,5X20H - CESTINO CM.20X27X11H -  
PRODUZIONE PATATE 7 KG/H**

EN Fryer lts. 6 singlephase - Tank cm. 22x32,5x20h  
- Basket cm. 20x27x11h - Production 7 kg/hr • DE  
Friteuse lt. 6 einphasig - Becken cm. 22x32,5x20h -  
Korb cm. 20x27x11h - Pommes frites 7 kg/h • FR  
Friteuse lt. 6 monophasé - Cuve cm. 22x32,5x20h -  
Panier cm. 20x27x11h - Production de pommes frites  
7 Kg/h • ES Freidoras 6 lt. monofásica - Cuba cm.  
22x32,5x20h - Cesta cm. 20x27x11h - Producción  
patatas 7 Kg/h  
**cm. 30x 51x 25h**



⚡ 3 kW \_\_\_\_\_ **898,00**  
230V~ \_\_\_\_\_ 13 / 0,08  
50/60 Hz

**FE-8**  
35010830

**FRIGGITRICE LT. 8 TRIFASE VASCA CM.  
22X32,5X20H - CESTINO CM.20X27X11H -  
PRODUZIONE PATATE 9 KG/H**

EN Fryer lts. 8 threephase - Tank cm. 22x32,5x20h  
- Basket cm. 20x27x11h - Production 9 kg/hr • DE  
Friteuse lt. 8 dreiphasig - Becken cm. 22x32,5x20h  
- Korb cm. 20x27x11h - Pommes frites 9 kg/h • FR  
Friteuse lt. 8 triphase - Cuve cm. 22x32,5x20h - Panier  
cm. 20x27x11h - Production de pommes frites 9 Kg/h  
• ES Freidoras 8 lt. trifásica - Cuba cm. 22x32,5x20h -  
Cesta cm. 20x27x11h - Producción patatas 9 Kg/h  
**cm. 30x 51x 25h**

⚡ 5,4 kW \_\_\_\_\_ **998,00**  
400V~3N \_\_\_\_\_ 15 / 0,08  
230V~3 \_\_\_\_\_  
50/60 Hz

# FRIGGITRICI ELETTRICHE - TOP

MOD. \_\_\_\_\_  
COD. \_\_\_\_\_

DESCRIZIONE/DESCRIPTION/BEZEICHNUNG/DESCRIPTION/DESCRIPCIÓN  
DIMENSIONI/DIMENSIONS/ABMESSUNGEN/DIMENSIONS/DIMENSIONES

POTENZA/POWER/LEISTUNG/PUISSANCE/POTENCIA  
VOLTAGGIO/VOLTAGE/SPANNUNG/VOLTAGE/VOLTAJE

⚡ kcal/h  
⚡ kW  
V~  
Hz

PREZZO/PRICE €  
PREIS/PRIX/PRECIO €  
KG / M<sup>3</sup>

**FE-10**  
35011030

**FRIGGITRICE LT. 10 TRIFASE VASCA CM. 29X32,5X20H - CESTINO CM.26X27X11H - PRODUZIONE PATATE 10 KG/H**

**EN** Fryer lts. 10 threephase - Tank cm. 29x32,5x20h - Basket cm. 26x27x11h - Production 10 kg/hr • **DE** Friteuse lt. 10 dreiphasig - Becken cm. 29x32,5x20h - Korb cm. 26x27x11h - Pommes frites 10 kg/h • **FR** Friteuse lt. 10 triphase - Cuve cm. 29x32,5x20h - Panier cm. 26x27x11h - Production de pommes frites 10 Kg/h • **ES** Freidoras 10 lt. trifásica - Cuba cm. 29x32,5x20h - Cesta cm. 26x27x11h - Producción patatas 10 Kg/h  
**cm. 40x 70x 25h**



⚡ 6 kW  
400V~3N  
230V~3  
50/60 Hz

**1.161,00**  
21 / 0,22

**FEM-2/6**  
35020610

**FRIGGITRICE LT. 6+6 MONOFASE 2 VASCHE CM. 22X32,5X20H - 2 CESTI CM.20X27X11H - PRODUZIONE PATATE 14 KG/H**

**EN** Fryer lts. 6+6 singlephase - 2 tanks cm. 22x32,5x20h - 2 baskets cm. 20x27x11h - Production 14 kg/hr • **DE** Friteuse lt. 6+6 einphasig - 2 Becke cm. 22x32,5x20h - 2 Korbe cm. 20x27x11h - Pommes frites 14 kg/h • **FR** Friteuse lt. 6+6 monophasé - 2 cuves cm. 22x32,5x20h - 2 Paniers cm. 20x27x11h - Production de pommes 14 Kg/h • **ES** Freidoras 6+6 lt. monofásica - 2 cubas cm. 22x32,5x20h - 2 cestas cm. 20x27x11h - Producción patatas 14 Kg/h  
**cm. 60x 51x 25h**



⚡ 6 kW  
230V~  
50/60 Hz

**1.679,00**  
13 / 0,16

**FE-2/8**  
35020830

**FRIGGITRICE LT. 8+8 TRIFASE 2 VASCHE CM. 22X32,5X20H - 2 CESTI CM.20X27X11H - PRODUZIONE PATATE 18 KG/H**

**EN** Fryer lts. 8+8 threephase - 2 tanks cm. 22x32,5x20h - 2 baskets cm. 20x27x11h - Production 18 kg/hr • **DE** Friteuse lt. 8+8 dreiphasig - 2 Becke cm. 22x32,5x20h - 2 Korbe cm. 20x27x11h - Pommes frites 18 kg/h • **FR** Friteuse lt. 8+8 triphase - 2 cuves cm. 22x32,5x20h - 2 Paniers cm. 20x27x11h - Production de pommes 18 Kg/h • **ES** Freidoras 8+8 lt. trifásica - 2 cubas cm. 22x32,5x20h - 2 cestas cm. 20x27x11h - Producción patatas 18 Kg/h  
**cm. 60x 51x 25h**

⚡ 10,8 kW  
400V~3N  
230V~3  
50/60 Hz

**1.760,00**  
27 / 0,16

**FE-2/10**  
35021030

**FRIGGITRICE LT. 10+10 TRIFASE 2 VASCHE CM. 29X32,5X20H - 2 CESTI CM.26X27X11H - PRODUZIONE PATATE 20 KG/H**

**EN** Fryer lts. 10+10 threephase - 2 tanks cm. 29x32,5x20h - 2 baskets cm. 26x27x11h - Production 20 kg/hr • **DE** Friteuse lt. 10+10 dreiphasig - 2 Becke cm. 29x32,5x20h - 2 Korbe cm. 26x27x11h - Pommes frites 20 kg/h • **FR** Friteuse lt. 10+10 triphase - 2 cuves cm. 29x32,5x20h - 2 Paniers cm. 26x27x11h - Production de pommes 20 Kg/h • **ES** Freidoras 10+10 lt. trifásica - 2 cubas cm. 29x32,5x20h - 2 cestas cm. 26x27x11h - Producción patatas 20 Kg/h  
**cm. 80x 70x 25h**



⚡ 12 kW  
400V~3N  
230V~3  
50/60 Hz

**2.019,00**  
38 / 0,42

**S-3**  
05210300

**CAVALLETTO BASE**

**EN** Stand • **DE** Untergestell • **FR** Piétement simple  
• **ES** Soporte base  
**cm. 30x 40x 55h**

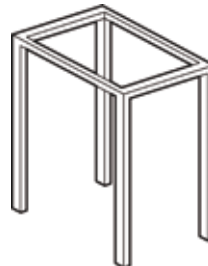

**177,00**  
2 / 0,12

**S-6**  
05210600

**cm. 60x 40x 55h**

**194,00**  
3 / 0,22

**R-3**  
05240300

**RIPIANO**

**EN** Shelf • **DE** Abstellbrett • **FR** Etagère • **ES** Estante  
**cm. 26x 39,5x 3h**



**85,00**  
1 / 0,01



Le immagini presentate non sono vincolanti. La ditta si riserva di apportare modifiche senza preavviso. • The pictures are purely representative. The manufacturer reserves the right to modify the technical data and models without previous notice. • Les images

**LO**

présentées ne nous engagent pas. La Société se réserve le droit d'apporter tout modification sans préavis. • Die dargestellten Abbildungen sind nicht verbindlich. Technische Änderungen vorbehalten. • Las imágenes presentadas no son vinculantes. El Fabricante se reserva el derecho de modificar sus productos sin previo aviso.

01/20

**387**

# ACCESSORI FRIGGITRICI

MOD. \_\_\_\_\_  
COD. \_\_\_\_\_

DESCRIZIONE/DESCRIPTION/BEZEICHNUNG/DESCRIPTION/DESCRIPCIÓN  
DIMENSIONI/DIMENSIONS/ABMESSUNGEN/DIMENSIONS/DIMENSIONES

POTENZA/POWER/LEISTUNG/PUISSANCE/POTENCIA  
VOLTAGGIO/VOLTAGE/SPANNUNG/VOLTAGE/VOLTAJE

⚡ kW kcal/h  
⚡ kW V~ Hz

PREZZO/PRICE €  
PREIS/PRIX/PRECIO €  
KG / M<sup>3</sup>

**R-6** cm. **56x 39,5x 3h**  
05240600

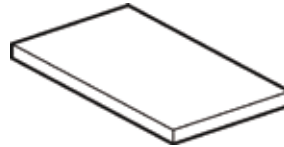

**106,00**  
2 / 0,01

**S-40** **CAVALLETTO CON RIPIANO**  
40210400 **EN** Stand with shelf • **DE** Untergestell offen mit boden  
• **FR** Support avec etagere • **ES** Soporte con estante  
cm. **40x 58,5x 60h**

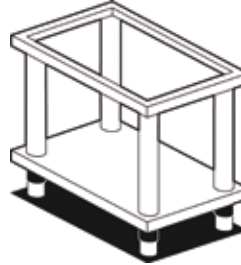

**404,00**  
20 / 0,18

**S-80** cm. **80x 58,5x 60h**  
40210800



**478,00**  
26 / 0,35

**M-40** **BASE A GIORNO**  
40220400 **EN** Open base unit • **DE** Untergestell offen • **FR** Base  
ouverte • **ES** Base abierta  
cm. **40x 58,5x 60h**



**330,00**  
14 / 0,18

**MP-40** **BASE CON PORTA**  
40220401 **EN** Stand with door • **DE** Unterbau mit Flügeltüren  
• **FR** Placard avec porte • **ES** Base con puerta  
cm. **40x 61,5x 60h**



**453,00**  
17 / 0,18

**MC-40** **BASE CON 2 CASSETTI GN 1/1 CON 2 GN 1/1**  
**H 15 IN PLASTICA**  
40220420 **EN** Stand with 2 drawers GN 1/1, with 2  
plastic containers GN 1/1 h 15 • **DE** Unterbau  
mit 2 Schubladen GN 1/1 mit 2 GN 1/1 h 15  
Kunststoffbehältern • **FR** Placard avec 2 tiroirs GN 1/1  
avec 2 bacs GN 1/1 h 15 en plastique • **ES** Base con 2  
cajones GN 1/1 con 2 GN 1/1 h 15 de plástico  
cm. **40x 61,5x 60h**



**711,00**  
28 / 0,18



# FRIGGITRICI ELETTRICHE

MOD. \_\_\_\_\_  
COD. \_\_\_\_\_

DESCRIZIONE/DESCRIPTION/BEZEICHNUNG/DESCRIPTION/DESCRIPCIÓN  
DIMENSIONI/DIMENSIONS/ABMESSUNGEN/DIMENSIONS/DIMENSIONES

POTENZA/POWER/LEISTUNG/PUISSANCE/POTENCIA  
VOLTAGGIO/VOLTAGE/SPANNUNG/VOLTAGE/VOLTAJE

⚡ kW kcal/h  
V~ Hz

PREZZO/PRICE €  
PREIS/PRIX/PRECIO €/M<sup>3</sup>

**FME-10**  
35311030

**FRIGGITRICE CON MOBILE - LT. 10 TRIFASE  
VASCA CM. 29X32,5X18,5H - CESTINO  
CM.26X27X11H. BACINELLA RACCOGLIOLIO  
CON FILTRO. PROD. PATATE: 10 KG/H**

**EN** Cabinet fryer lt. 10 threephase Bowl cm. 29x32,5x18,5h - Basket cm. 26x27x11h. Drip tray with sieve. Production: 10 kg/h • **DE** Standfriteuse lt. 10 dreiphasig Becken cm. 29x32,5x18,5h - Korb cm. 26x27x11h. Fettauffangschale mit Sieb. Pommes frites: 10 kg/h • **FR** Friteuse sur placard lt.10 triphase Cuve cm. 29x32,5x18,5h - Panier cm. 26x27x11h. Collecteur d'huile avec filtre. Production de pommes frites: 10 kg/h • **ES** Freidoras con mueble 10 lt. trifásica Cuba cm. 29x32,5x18,5h - Cesta cm. 26x27x11h. Bandeja recoge aceite con filtro. Producción patatas: 10 Kg/h  
**cm. 40x 70x 85h**



⚡ 6 kW 1.505,00  
400V~3N 35 / 0,36  
230V~3  
50/60 Hz

**FME-15**  
35311530

**FRIGGITRICE CON MOBILE - LT. 15 TRIFASE  
VASCA CM. 33X40X18,5H - CESTINO  
CM.30X33X12H. BACINELLA RACCOGLIOLIO  
CON FILTRO. PROD. PATATE: 12 KG/H**

**EN** Cabinet fryer lt. 15 threephase Bowl cm. 33x40x18,5h - Basket cm. 30x33x12h. Drip tray with sieve. Production: 12 kg/h • **DE** Standfriteuse lt. 15 dreiphasig Becken cm. 33x40x18,5h - Korb cm. 30x33x12h. Fettauffangschale mit Sieb. Pommes frites: 12 kg/h • **FR** Friteuse sur placard lt.15 triphase Cuve cm. 33x40x18,5h - 2 Paniers cm. 30x33x12h. Collecteur d'huile avec filtre. Production de pommes frites: 12 kg/h • **ES** Freidoras con mueble 15 lt. trifásica Cuba cm. 33x40x18,5h - Cesta cm. 30x33x12h. Bandeja recoge aceite con filtro. Producción patatas: 12 Kg/h  
**cm. 40x 70x 85h**

⚡ 9 kW 1.755,00  
400V~3N 42 / 0,36  
50/60 Hz

**FME-2/10**  
35321030

**FRIGGITRICE CON MOBILE - LT. 10+10 TRIFASE  
2 VASCHE CM. 29X32,5X18,5H - 2 CESTI  
CM.26X27X11H. 2 BACINELLE RACCOGLIOLIO  
CON FILTRO. PRODUZIONE PATATE 20 KG/H**

**EN** Cabinet fryer lt. 10+10 threephase 2 tanks cm. 29x32,5x18,5h - 2 baskets cm. 26x27x11h. 2 drip trays with sieves. Production 20 kg/hr • **DE** Standfriteuse lt. 10+10 dreiphasig 2 Becke cm. 29x32,5x18,5h - 2 Korbe cm. 26x27x11h. 2 Fettauffangschalen mit Sieb. Pommes frites 20 kg/pro Stunde • **FR** Friteuse sur placard lt.10+10 triphase 2 cuves cm. 29x32,5x18,5h - 2 Paniers cm. 26x27x11h. 2 bacs de récupération de l'huile avec filtre. Production de pommes 20 Kg/h • **ES** Freidoras con mueble 10+10 lt. trifásica 2 cubas cm. 29x32,5x18,5h - 2 cestas cm. 26x27x11h. 2 bandejas recoge aceite con filtro. Producción patatas 20 Kg/h  
**cm. 80x 70x 85h**



⚡ 12 kW 2.576,00  
400V~3N 65 / 0,70  
230V~3  
50/60 Hz

**FME-2/15**  
35321530

**FRIGGITRICE CON MOBILE - LT. 15+15  
TRIFASE 2 VASCHE CM. 33X40X18,5H -  
2 CESTI CM.30X33X12H. 2 BACINELLA  
RACCOGLIOLIO CON FILTRO. PRODUZIONE  
PATATE 24 KG/H**

**EN** Cabinet fryer lt. 15+15 threephase 2 tanks cm. 33x40x18,5h - 2 baskets cm. 30x33x12h. 2 drip trays with sieves. Production 24 kg/hr • **DE** Standfriteuse lt. 15+15 dreiphasig 2 Becke cm. 33x40x18,5h - 2 Korbe cm. 30x33x12h. 2 Fettauffangschalen mit Sieb. Pommes frites 24 kg/pro Stunde • **FR** Friteuse sur placard lt.15+15 triphase 2 cuves cm. 33x40x18,5h - 2 Paniers cm. 30x33x12h. 2 bacs de récupération de l'huile avec filtre. Production de pommes 24 Kg/h • **ES** Freidoras con mueble 15+15 lt. trifásica 2 cubas cm. 33x40x18,5h - 2 cestas cm. 30x33x12h. 2 bandejas recoge aceite con filtro. Producción patatas 24 Kg/h  
**cm. 80x 70x 85h**

⚡ 18 kW 2.803,00  
400V~3N 75 / 0,70  
50/60 Hz



Le immagini presentate non sono vincolanti. La ditta si riserva di apportare modifiche senza preavviso. • The pictures are purely representative. The manufacturer reserves the right to modify the technical data and models without previous notice. • Les images

LO

présentées ne nous engagent pas. La Société se réserve le droit d'apporter tout modification sans préavis. • Die dargestellten Abbildungen sind nicht verbindlich. Technische Änderungen vorbehalten. • Las imágenes presentadas no son vinculantes. El Fabricante se reserva el derecho de modificar sus productos sin previo aviso.

01/20

389

# ACCESSORI FRIGGITRICI

MOD. \_\_\_\_\_  
COD. \_\_\_\_\_

DESCRIZIONE/DESCRIPTION/BEZEICHNUNG/DESCRIPTION/DESCRIPCIÓN  
DIMENSIONI/DIMENSIONS/ABMESSUNGEN/DIMENSIONS/DIMENSIONES

POTENZA/POWER/LEISTUNG/PUISSANCE/POTENCIA  
VOLTAGGIO/VOLTAGE/SPANNUNG/VOLTAGE/VOLTAJE

⚡ kW kcal/h  
⚡ kw V~ Hz

PREZZO/PRICE €  
PREIS/PRIX/PRECIO €  
KG / M<sup>3</sup>

## 531013500 CESTINO 1/2 PER FME-15

EN Basket 1/2 for FME-15 • DE Korb 1/2 für Friteuse FME-15 • FR Panier 1/2 pour FME-15 • ES Cesta 1/2 para FME-15  
cm. 14x 33x 12h



57,00  
0.8 / 0,04

## 531014400 CESTINO 1/2 PER FME-10

EN Basket 1/2 for FME-10 • DE Korb 1/2 für Friteuse FME-10 • FR Panier 1/2 pour FME-10 • ES Cesta 1/2 para FME-10  
cm. 10x 25x 10h

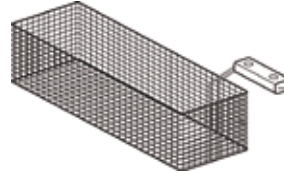

41,00  
0.6 / 0,03

FPE-20  
35032030

## FRIGGITRICE PASTICCERIA TRIFASE - 17 LITRI VASCA CM. 50X42,5X17,5H - 1 CESTO CM. 47X35X8H FILTRO E COPERCHIO VASCA

EN Confectioner's fryer threephase - 17 liters Tank cm. 50x42,5x17,5h - 1 basket cm. 47x35x8h Sieve and lid for tank • DE Friteuse für Konditorei dreiphasig - 17 Liter Becken cm. 50x42,5x17,5h - 1 Korb cm. 47x35x8h Filter und Deckel für Becken • FR Friteuse patisserie triphase - 17 litres Cuve cm. 50x42,5x17,5h - 1 panier cm. 47x35x8h Filtre et couvercle pour cuve • ES Freidora repostería trifásica - 17 litros Cuba cm. 50x42,5x17,5h - 1 cesta cm. 47x35x8h Filtro y tapa cuba  
cm. 60x 70x 25h

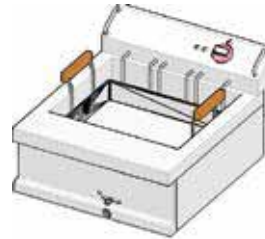

⚡ 6,6 kW 1.458,00  
400V~3N 32 / 0,31  
230V~3  
50/60 Hz

FPE-25  
35032540

## FRIGGITRICE PASTICCERIA TRIFASE - 24 LITRI VASCA CM. 70X42,5X17,5H - 1 CESTO CM. 67X35X8H FILTRO E COPERCHIO VASCA

EN Confectioner's fryer threephase - 24 liters Tank cm. 70x42,5x17,5h - 1 basket cm. 67x35x8h Sieve and lid for tank • DE Friteuse für Konditorei dreiphasig - 24 Liter Becken cm. 70x42,5x17,5h - 1 Korb cm. 67x35x8h Filter und Deckel für Becken • FR Friteuse patisserie triphase - 24 litres Cuve cm. 70x42,5x17,5h - 1 panier cm. 67x35x8h Filtre et couvercle pour cuve • ES Freidora repostería trifásica - 24 litros Cuba cm. 70x42,5x17,5h - 1 cesta cm. 67x35x8h Filtro y tapa cuba  
cm. 80x 70x 25h



⚡ 10,2 kW 1.840,00  
230V~3 40 / 0,40  
50/60 Hz

FPE-25  
35032530

cm. 80x 70x 25h

⚡ 10,2 kW 1.840,00  
400V~3N 40 / 0,40  
50/60 Hz

FPEH-25  
35032531

## FRIGGITRICE PASTICCERIA POTENZIATA TRIFASE - 24 LITRI VASCA CM. 70X42,5X17,5H - 1 CESTO CM. 67X35X8H FILTRO E COPERCHIO VASCA

EN Powerfull Confectioner's fryer threephase - 24 liters Tank cm. 70x42,5x17,5h - 1 basket cm. 67x35x8h Sieve and lid for tank • DE Friteuse leistungsfähiges für Konditorei dreiphasig - 24 Liter Becken cm. 70x42,5x17,5h - 1 Korb cm. 67x35x8h Filter und Deckel für Becken • FR Friteuse patisserie triphase plus puissants- 24 litres Cuve cm. 70x42,5x17,5h - 1 panier cm. 67x35x8h Filtre et couvercle pour cuve • ES Freidora repostería trifásica con mayor potencia - 24 litros Cuba cm. 70x42,5x17,5h - 1 cesta cm. 67x35x8h Filtro y tapa cuba  
cm. 80x 70x 25h

⚡ 18 kW 2.000,00  
400V~3N 40 / 0,40  
50/60 Hz

# FRIGGITRICI PASTICCERIA A GAS - TOP

MOD. \_\_\_\_\_  
COD. \_\_\_\_\_

DESCRIZIONE/DESCRIPTION/BEZEICHNUNG/DESCRIPTION/DESCRIPCIÓN  
DIMENSIONI/DIMENSIONS/ABMESSUNGEN/DIMENSIONS/DIMENSIONES

POTENZA/POWER/LEISTUNG/PUISSANCE/POTENCIA  
VOLTAGGIO/VOLTAGE/SPANNUNG/VOLTAGE/VOLTAJE

⚡ kW  
kcal/h

⚡ kw  
V~  
Hz

PREZZO/PRICE €  
PREIS/PRIX/PRECIO  
KG / M<sup>3</sup>

**FPG-20**  
40032050

**FRIGGITRICE PASTICCERIA GAS - 20 LITRI**  
**VASCA CM. 50X38X24H - 1 CESTO CM.**  
**47X35X8H FILTRO E COPERCHIO VASCA**  
**EN** Gas confectioner's fryer - 20 liters Tank cm. 50x38x24h - 1 basket cm. 47x35x8h Sieve and lid for tank • **DE** Gasfriteuse für Konditorei - 20 Liter Becken cm. 50x38x24h - 1 Korb cm. 47x35x8h Filter und Deckel für Becken • **FR** Friteuse patisserie à gaz - 20 litres Cuve cm. 50x38x24h - 1 panier cm. 47x35x8h Filtre et couvercle pour cuve • **ES** Freidora repostería gas - 20 litros Cuba cm. 50x38x24h - 1 cesta cm. 47x35x8h Filtro y tapa cuba  
**cm. 60x 70x 25h**

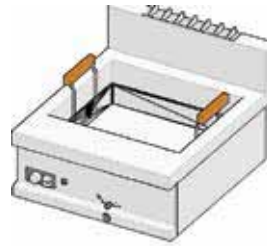

⚡ 11,2 kW  
9.630 kcal/h

**2.050,00**  
43 / 0,31

**FPG-30**  
40033050

**FRIGGITRICE PASTICCERIA GAS - 28 LITRI**  
**VASCA CM. 70X38X24H - 1 CESTO CM.**  
**67X35X8H FILTRO E COPERCHIO VASCA**  
**EN** Gas confectioner's fryer - 28 liters Tank cm. 70x38x24h - 1 basket cm. 67x35x8h Sieve and lid for tank • **DE** Gasfriteuse für Konditorei - 28 Liter Becken cm. 70x38x24h - 1 Korb cm. 67x35x8h Filter und Deckel für Becken • **FR** Friteuse patisserie à gaz - 28 litres Cuve cm. 70x38x24h - 1 panier cm. 67x35x8h Filtre et couvercle pour cuve • **ES** Freidora repostería gas - 28 litros Cuba cm. 70x38x24h - 1 cesta cm. 67x35x8h Filtro y tapa cuba  
**cm. 80x 70x 25h**



⚡ 16,5 kW  
14.190 kcal/h

**2.371,00**  
57 / 0,40

**S-60**  
40210600

**CAVALLETTO CON RIPIANO**  
**EN** Stand with shelf • **DE** Untergestell offen mit boden • **FR** Support avec etagere • **ES** Soporte con estante  
**cm. 60x 58,5x 60h**



**405,00**  
23 / 0,27

**S-80**  
40210800

**cm. 80x 58,5x 60h**

**478,00**  
26 / 0,35

**M-60**  
40220600

**BASE A GIORNO**  
**EN** Open base unit • **DE** Untergestell offen • **FR** Base ouverte • **ES** Base abierta  
**cm. 60x 58,5x 60h**



**541,00**  
18 / 0,27

**M-80**  
40220800

**cm. 80x 58,5x 60h**

**614,00**  
22 / 0,35

**MP-60**  
40220602

**BASE CON PORTE**  
**EN** Stand with doors • **DE** Unterbau mit Flügeltüren • **FR** Placard avec portes • **ES** Base con puertas  
**cm. 60x 61,5x 60h**



**707,00**  
23 / 0,27

**MP-80**  
40220802

**cm. 80x 61,5x 60h**

**790,00**  
28 / 0,35

**MCP-80**  
40220821

**BASE CON PORTA E CASSETTI 2 X GN 1/1 H 15 IN PLASTICA**  
**EN** Stand with door and drawers 2 plastic containers GN 1/1 h 15 • **DE** Unterbau mit Flügeltür und Schubladen 2 x GN 1/1 h 15 Kunststoffbehältern • **FR** Placard avec porte et tiroirs 2 bacs GN 1/1 h 15 en plastique • **ES** Base con puerta y cajones 2 x GN 1/1 h 15 de plástico  
**cm. 80x 61,5x 60h**



**1.222,00**  
40 / 0,35



Le immagini presentate non sono vincolanti. La ditta si riserva di apportare modifiche senza preavviso. • The pictures are purely representative. The manufacturer reserves the right to modify the technical data and models without previous notice. • Les images

**LO**

présentées ne nous engagent pas. La Société se réserve le droit d'apporter tout modification sans préavis. • Die dargestellten Abbildungen sind nicht verbindlich. Technische Änderungen vorbehalten. • Las imágenes presentadas no son vinculantes. El Fabricante se reserva el derecho de modificar sus productos sin previo aviso.

01/20

**391**

MOD. \_\_\_\_\_  
COD. \_\_\_\_\_

DESCRIZIONE/DESCRIPTION/BEZEICHNUNG/DESCRIPTION/DESCRIPCIÓN  
DIMENSIONI/DIMENSIONS/ABMESSUNGEN/DIMENSIONS/DIMENSIONES

POTENZA/POWER/LEISTUNG/PUISSANCE/POTENCIA  
VOLTAGGIO/VOLTAGE/SPANNUNG/VOLTAGE/VOLTAJE

⚡ kW \_\_\_\_\_  
kcal/h \_\_\_\_\_  
V~ \_\_\_\_\_  
Hz \_\_\_\_\_

PREZZO/PRICE € \_\_\_\_\_  
PREIS/PRIX/PRECIO € \_\_\_\_\_  
KG / M<sup>3</sup> \_\_\_\_\_

**MC-80**  
40220820

**BASE CON 2 CASSETTI GN 2/1 CON 4 GN 1/1 H 15 IN PLASTICA**

EN Stand with 2 drawers GN 2/1, with 4 plastic containers GN 1/1 h 15 • DE Unterbau mit 2 Schubladen GN 2/1 mit 4 GN 1/1 h 15 Kunststoffbehältern • FR Placard avec 2 tiroirs GN 2/1 avec 4 bacs GN 1/1 h 15 en plastique • ES Base con 2 cajones GN 2/1 con 4 GN 1/1 h 15 de plástico  
**cm. 80x 61,5x 60h**



**1.222,00**  
41 / 0,35

**FMPE-20**  
35332030

**FRIGGITRICE PASTICCERIA SU MOBILE TRIFASE - 17 LITRI VASCA CM. 50X42,5X17,5H - 1 CESTO CM. 47X35X8H FILTRO E COPERCHIO VASCA - BACINELLA RACCOGLIOLIO CON FILTRO**

EN Confectioner's cabinet fryer threephase - 17 liters Tank cm. 50x42,5x17,5h - 1 basket cm. 47x35x8h Sieve and lid for tank. Drip tray with sieve • DE Friteuse für Konditorei mit Untergestell dreiphasig - 17 Liter Becken cm. 50x42,5x17,5h - 1 Korb cm. 47x35x8h Sieb und Deckel für Becken - Fettauffangschale mit Sieb • FR Friteuse patisserie sur placard triphase - 17 litres Cuve cm. 50x42,5x17,5h - 1 panier cm. 47x35x8h Filtre et couvercle pour cuve - Collecteur d'huile avec filtre • ES Freidora repostería en mueble trifásica - 17 litros Cuba cm. 50x42,5x17,5h - 1 cesta cm. 47x35x8h Filtro y tapa cuba - Bandeja recoge aceite con filtro  
**cm. 60x 70x 85h**



⚡ 6,6 kW \_\_\_\_\_ **2.164,00**  
400V~3N \_\_\_\_\_ 60 / 0,59  
230V~3 \_\_\_\_\_  
50/60 Hz \_\_\_\_\_

**FMPE-25**  
35332540

**FRIGGITRICE PASTICCERIA TRIFASE - 24 LITRI VASCA CM. 70X42,5X17,5H - 1 CESTO CM. 67X35X8H FILTRO E COPERCHIO VASCA - BACINELLA RACCOGLIOLIO CON FILTRO**

EN Confectioner's cabinet fryer threephase - 24 liters - Tank cm. 70x42,5x17,5h 1 basket cm. 67x35x8h - Sieve and lid for tank - Drip tray with sieve • DE Friteuse für Konditorei mit Untergestell dreiphasig - 24 Liter - Becken cm. 70x42,5x17,5h 1 Korb cm. 67x35x8h - Einlegesieb mit Deckel für Becken - Fettauffangschale mit Sieb • FR Friteuse patisserie triphase - 24 litres - Cuve cm. 70x42,5x17,5h. 1 panier cm. 67x35x8h Filtre et couvercle pour cuve - Collecteur d'huile avec filtre • ES Freidora repostería trifásica - 24 litros - Cuba cm. 70x42,5x17,5h - 1 cesta cm. 67x35x8h Filtro y tapa cuba - Bandeja recoge aceite con filtro  
**cm. 80x 70x 85h**



⚡ 10,2 kW \_\_\_\_\_ **2.577,00**  
230V~3 \_\_\_\_\_ 72 / 0,78  
50/60 Hz \_\_\_\_\_

**FMPE-25**  
35332530

**cm. 80x 70x 85h**

⚡ 10,2 kW \_\_\_\_\_ **2.577,00**  
400V~3N \_\_\_\_\_ 72 / 0,78  
50/60 Hz \_\_\_\_\_

**FMPEH-25**  
35332531

**FRIGGITRICE PASTICCERIA POTENZIATA - 24 LITRI VASCA CM. 70X42,5X17,5H - 1 CESTO CM. 67X35X8H FILTRO E COPERCHIO VASCA - BACINELLA RACCOGLIOLIO CON FILTRO**

EN Powerfull Confectioner's cabinet fryer - 24 liters - Tank cm. 70x42,5x17,5h 1 basket cm. 67x35x8h - Sieve and lid for tank - Drip tray with sieve • DE Friteuse leistungsfähiges für Konditorei mit Untergestell - 24 Liter - Becken cm. 70x42,5x17,5h 1 Korb cm. 67x35x8h - Einlegesieb mit Deckel für Becken - Fettauffangschale mit Sieb • FR Friteuse patisserie plus puissants - 24 litres - Cuve cm. 70x42,5x17,5h. 1 panier cm. 67x35x8h Filtre et couvercle pour cuve - Collecteur d'huile avec filtre • ES Freidora repostería con mayor potencia - 24 litros - Cuba cm. 70x42,5x17,5h - 1 cesta cm. 67x35x8h Filtro y tapa cuba - Bandeja recoge aceite con filtro  
**cm. 80x 70x 85h**

⚡ 18 kW \_\_\_\_\_ **2.737,00**  
400V~3N \_\_\_\_\_ 72 / 0,78  
50/60 Hz \_\_\_\_\_

# FRIGGITRICI PASTICCERIA ELETTRICHE

MOD. \_\_\_\_\_  
COD. \_\_\_\_\_

DESCRIZIONE/DESCRIPTION/BEZEICHNUNG/DESCRIPTION/DESCRIPCIÓN  
DIMENSIONI/DIMENSIONS/ABMESSUNGEN/DIMENSIONS/DIMENSIONES

POTENZA/POWER/LEISTUNG/PUISSANCE/POTENCIA  
VOLTAGGIO/VOLTAGE/SPANNUNG/VOLTAGE/VOLTAJE

⚡ kW kcal/h  
⚡ kW V~ Hz

PREZZO/PRICE €  
PREIS/PRIX/PRECIO €  
KG / M<sup>3</sup>

**FMPE-30**  
35333030

**FRIGGITRICE PASTICCERIA TRIFASE - 31 LITRI**  
**VASCA CM. 90X42,5X17,5H - 1 CESTO CM.**  
**87X35X8H FILTRO E COPERCHIO VASCA -**  
**BACINELLA RACCOGLIOLIO CON FILTRO**  
**EN** Confectioner's cabinet fryer threephase - 31 liters - Tank cm. 90x42,5x17,5h 1 basket cm. 87x35x8h - Sieve and lid for tank - Drip tray with sieve • **DE** Friteuse für Konditorei mit Untergestell dreiphasig - 31 Liter - Becken cm. 90x42,5x17,5h 1 Korb cm. 87x35x8h - Einlegesieb mit Deckel für Becken - Fettauffangschale mit Sieb • **FR** Friteuse patisserie triphase - 31 litres - Cuve cm. 90x42,5x17,5h. 1 panier cm. 87x35x8h Filtre et couvercle pour cuve - Collecteur d'huile avec filtre • **ES** Freidora repostería trifásica - 31 litros - Cuba cm. 90x42,5x17,5h - 1 cesta cm. 87x35x8h Filtro y tapa cuba - Bandeja recoge aceite con filtro  
**cm. 100x 70x 85h**



⚡ 13,2 kW **3.208,00**  
400V~3N 83 / 1,06  
50/60 Hz

**FMPG-20**  
40342050

**FRIGGITRICE PASTICCERIA GAS - 20 LITRI**  
**VASCA CM. 50X38X24H - 1 CESTO CM.**  
**47X35X8H FILTRO E COPERCHIO VASCA -**  
**BACINELLA RACCOGLIOLIO CON FILTRO**  
**EN** Confectioner's cabinet fryer gas - 20 liters Tank cm. 50x38x24h - 1 basket cm. 47x35x8h Sieve and lid for tank. Drip tray with sieve • **DE** Friteuse für Konditorei mit Untergestell gas - 20 Liter Becken cm. 50x38x24h - 1 Korb cm. 47x35x8h Sieb und Deckel für Becken - Fettauffangschale mit Sieb • **FR** Friteuse patisserie sur placard à gaz - 20 litres Cuve cm. 50x38x24h - 1 panier cm. 47x35x8h Filtre et couvercle pour cuve - Collecteur d'huile avec filtre • **ES** Freidora repostería en mueble a gas - 20 litros Cuba cm. 50x38x24h - 1 cesta cm. 47x35x8h Filtro y tapa cuba - Bandeja recoge aceite con filtro  
**cm. 60x 70x 85h**



⚡ 11,2 kW **2.892,00**  
9.630 kcal/h 68 / 0,78

**FMPG-30**  
40343050

**FRIGGITRICE PASTICCERIA GAS - 28 LITRI**  
**VASCA CM. 70X38X24H - 1 CESTO CM.**  
**67X35X8H - FILTRO E COPERCHIO VASCA -**  
**BACINELLA RACCOGLIOLIO CON FILTRO**  
**EN** Confectioner's cabinet fryer gas - 28 liters - Tank cm. 70x38x24h - 1 basket cm. 67x35x8h Sieve and lid for tank. Drip tray with sieve • **DE** Friteuse für Konditorei mit Untergestell gas - 28 Liter - Becken cm. 70x38x24h - 1 Korb cm. 67x35x8h Sieb und Deckel für Becken - Fettauffangschale mit Sieb • **FR** Friteuse patisserie sur placard à gaz - 28 litres - Cuve cm. 70x38x24h - 1 panier cm. 67x35x8h Filtre et couvercle pour cuve - Collecteur d'huile avec filtre • **ES** Freidora repostería en mueble a gas - 28 litros - Cuba cm. 70x38x24h - 1 cesta cm. 67x35x8h Filtro y tapa cuba - Bandeja recoge aceite con filtro  
**cm. 80x 70x 85h**



⚡ 16,5 kW **3.318,00**  
14.190 kcal/h 84 / 1,06

**40280600**

**SCIVOLO INOX 60**  
**EN** Stainless steel slide 60 • **DE** Rutsche aus Rostfreiem Stahl 60 • **FR** Goulotte en acier inox 60 • **ES** Deslizador inox 60  
**cm. 38x 55x 27h**

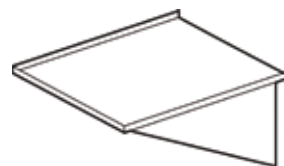

**113,00**  
4 / 0,07

**40280800**

**SCIVOLO INOX 80 / F45**  
**EN** Stainless steel slide 80 / F45 • **DE** Rutsche aus Rostfreiem Stahl 80 / F45 • **FR** Goulotte en acier inox 80 / F45 • **ES** Deslizador inox 80 / F45  
**cm. 38x 75x 27h**

**126,00**  
5 / 0,09

**40281000**

**SCIVOLO INOX 100**  
**EN** Stainless steel slide 100 • **DE** Rutsche aus Rostfreiem Stahl 100 • **FR** Goulotte en acier inox 100 • **ES** Deslizador inox 100  
**cm. 38x 95x 27h**

**145,00**  
6 / 0,12



Le immagini presentate non sono vincolanti. La ditta si riserva di apportare modifiche senza preavviso. • The pictures are purely representative. The manufacturer reserves the right to modify the technical data and models without previous notice. • Les images

**LO**

présentées ne nous engagent pas. La Société se réserve le droit d'apporter tout modification sans préavis. • Die dargestellten Abbildungen sind nicht verbindlich. Technische Änderungen vorbehalten. • Las imágenes presentadas no son vinculantes. El Fabricante se reserva el derecho de modificar sus productos sin previo aviso.

01/20

**393**



MOD. \_\_\_\_\_  
COD. \_\_\_\_\_

DESCRIZIONE/DESCRIPTION/BEZEICHNUNG/DESCRIPTION/DESCRIPCIÓN  
DIMENSIONI/DIMENSIONS/ABMESSUNGEN/DIMENSIONS/DIMENSIONES

POTENZA/POWER/LEISTUNG/PUISSANCE/POTENCIA  
VOLTAGGIO/VOLTAGE/SPANNUNG/VOLTAGE/VOLTAJE

⚡ kW kcal/h  
V~ Hz

PREZZO/PRICE €  
PREIS/PRIX/PRECIO €  
KG / M<sup>3</sup>

**40290800 MITRA 800**  
**EN** Chimney jack 800 • **DE** Lüftungsaufsatz 800 • **FR** Mitre 800 • **ES** Caperuza 800

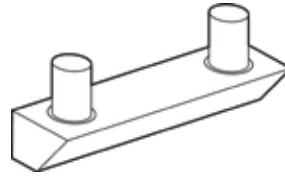

**505,00**  
9 / 0,04

**CA-11 CAMINO ANTIVENTO (OBBLIGATORIO PER FPG-30, FMPG-30, IN GERMANIA, OLANDA E AUSTRIA: MITRA PER ESTRAZIONE FORZATA FUMI COMBUSTI. MITRA + CAMINO ANTIVENTO PER ESTRAZIONE NATURALE FUMI COMBUSTI.)**



**240,00**  
5 / 0,01

**EN** Draught diverter (Obligatory for FPG-30, FMPG-30, in Germany, Holland and Austria: Chimney jack for forced extraction of burnt smoke. Chimney jack + draught diverter for natural extraction of burnt smoke.)  
• **DE** Strömungssicherung (Pflicht für FPG-30, FMPG-30, in Deutschland, Holland e Österreich: Lüftungsaufsatz zur erzwungenen Wrasenabführung. Lüftungsaufsatz + Strömungssicherung zur natürlichen Wrasenabführung.)  
• **FR** Cheminee anti-vent (Obligatoire pour FPG-30, FMPG-30 en Allemagne, Hollande et Autriche: Mitre pour sortie forcée des fumées brûlées. Mitre + cheminee anti-vent pour sortie naturelle des fumées brûlées.)  
• **ES** Chimenea contra viento (Obligatorio para FPG-30, FMPG-30 en Alemania, Holanda y Austria Caperuza para la extracción forzada de humos de combustión. Caperuza + chimenea contra viento para la extracción natural de humos de combustión.)  
**cm. Ø 11**

**F45-78ET FRIGGITRICE TRIFASE LT. 45 VASCA CM. 70X38X38H - 1 CESTO CM. 65X33X17H - FILTRO E COPERCHIO VASCA. BACINELLA RACCOGLIOLIO CON FILTRO. PRODUZIONE PATATE: 40 KG/H (INCLUSA 1 TESTATA CHIUSURA PIANO MOD.TPA-7)**



⚡ 40 kW **3.709,00**  
400V~3N 96 / 0,71  
50/60 Hz

**EN** Fryer threephase 45 lts - Bowl cm. 70x38x38h - 1 basket cm. 65x33x17h. Sieve and lid for pan. Drip tray with sieve. Production: 40 kg/h (included 1 Head end filler strip mod.TPA-7) • **DE** Friteuse dreiphasig lt. 45 - Becken cm. 70x38x38h - 1 Korb cm. 65x33x17h. Einlegesieb und Deckel für Becken. Fettauffangschale mit Sieb. Pommes frites: 40 kg/h (inbegriffen 1 Abschluss-Element mod.TPA-7) • **FR** Friteuse triphase lt. 45 - Cuve cm. 70x38x38h - 1 Panier cm. 65x33x17h. Filtre, couvercle pour cuve. Bac de récupération de l'huile avec filtre. Production de pommes frites: 40 kg/h (inclus 1 Élément de jonction top mod.TPA-7) • **ES** Freidoras trifásico 45 lt. - Cuba cm. 70x38x38h - 1 cesta cm. 65x33x17h. Filtro y tapa para cuba. Bandeja recoge aceite con filtro. Prod. patatas: 40 Kg/h (incluida 1 Chapa de cierre para top mod.TPA-7)  
**cm. 80x 70,5x 90h**

# FRIGGITRICI PASTICCERIA 45 LT

MOD. \_\_\_\_\_  
COD. \_\_\_\_\_

DESCRIZIONE/DESCRIPTION/BEZEICHNUNG/DESCRIPTION/DESCRIPCIÓN  
DIMENSIONI/DIMENSIONS/ABMESSUNGEN/DIMENSIONS/DIMENSIONES

POTENZA/POWER/LEISTUNG/PUISSANCE/POTENCIA  
VOLTAGGIO/VOLTAGE/SPANNUNG/VOLTAGE/VOLTAJE

⚡ kW  
kcal/h

⚡ kW  
V~  
Hz

PREZZO/PRICE €  
PREIS/PRIX/PRECIO €  
KG / M<sup>3</sup>

**F45-78G**  
08260855

**FRIGGITRICE GAS LT. 45 VASCA CM. 70X38X38H. - 1 CESTO CM. 65X33X17H. FILTRO E COPERCHIO VASCA. BACINELLA RACCOGLIOLIO CON FILTRO. PROD. PATATE: 40 KG/H (INCLUDE ENTRAMBE LE TESTATE CHIUSURA PIANO)**

**EN** Gas Fryer 45 lts - Bowl cm. 70x38x38h - 1 basket cm. 65x33x17h. Sieve and lid for pan. Drip tray with sieve. Production: 40 kg/h (included both Heads end filler strip) • **DE** Gas-Friteuse lt. 45 - Becken cm. 70x38x38h - 1 Korb cm. 65x33x17h. Einlegesieb und Deckel für Becken. Fettaufschale mit Sieb. Pommes frites: 40 kg/h (inbegriffen alle 2 Abschluss-Element) • **FR** Friteuse a gaz lt. 45 - Cuve cm. 70x38x38h - 1 Panier cm. 65x33x17h. Filtre, couvercle pour cuve. Bac de récupération de l'huile avec filtre. Production de pommes frites: 40 kg/h (inclus tous 2 Elément de jonction top) • **ES** Freidoras a gas 45 lt. - Cuba cm. 70x38x38h - 1 cesta cm. 65x33x17h. Filtro y tapa para cuba. Bandeja recoge aceite con filtro. Prod. patatas: 40 Kg/h (incluidas todas las 2 Chapa de cierre para top) **cm. 80x 70,5x 90h**



⚡ 44 kW  
37.840 kcal/h **4.487,00**  
110 / 1,07

⚡ 0,005 KW  
230V~  
50 Hz

**531033300 CESTO 1/1 F45**

**EN** Basket 1/1 F45 • **DE** korb 1/1 F45 • **FR** Panier 1/1 F45 • **ES** Cesta 1/1 F45  
**cm. 65x 33x 17h**



**162,00**  
3 / 0,10

**531041300 CESTO 1/2 F45**

**EN** Basket 1/2 F45 • **DE** korb 1/2 F45 • **FR** Panier 1/2 F45 • **ES** Cesta 1/2 F45  
**cm. 28x 29x 15h**



**68,00**  
1.5 / 0,06

**531047800 CESTO 1/3 F45**

**EN** Basket 1/3 F45 • **DE** korb 1/3 F45 • **FR** Panier 1/3 F45 • **ES** Cesta 1/3 F45  
**cm. 21,5x 33x 16,5h**



**79,00**  
1.3 / 0,06

**531017500 CESTINO 60**

**EN** Basket 60 • **DE** Fritierkorb 60 • **FR** Panier 60 • **ES** Cesta 60  
**cm. 47x 35x 8h**



**99,00**  
1.5 / 0,06

**531016900 CESTINO 80**

**EN** Basket 80 • **DE** Fritierkorb 80 • **FR** Panier 80 • **ES** Cesta 80  
**cm. 67x 35x 8h**

**104,00**  
2 / 0,08

**531017700 CESTINO 100**

**EN** Basket 100 • **DE** Fritierkorb 100 • **FR** Panier 100 • **ES** Cesta 100  
**cm. 87x 35x 8h**

**155,00**  
2.5 / 0,10



Le immagini presentate non sono vincolanti. La ditta si riserva di apportare modifiche senza preavviso. • The pictures are purely representative. The manufacturer reserves the right to modify the technical data and models without previous notice. • Les images

**LO**

présentées ne nous engagent pas. La Société se réserve le droit d'apporter tout modification sans préavis. • Die dargestellten Abbildungen sind nicht verbindlich. Technische Änderungen vorbehalten. • Las imágenes presentadas no son vinculantes. El Fabricante se reserva el derecho de modifi car sus productos sin previo aviso.

01/20

**395**

# ACCESSORI PASTICCERIA

MOD. \_\_\_\_\_  
COD. \_\_\_\_\_

DESCRIZIONE/DESCRIPTION/BEZEICHNUNG/DESCRIPTION/DESCRIPCIÓN  
DIMENSIONI/DIMENSIONS/ABMESSUNGEN/DIMENSIONS/DIMENSIONES

POTENZA/POWER/LEISTUNG/PUISSANCE/POTENCIA  
VOLTAGGIO/VOLTAGE/SPANNUNG/VOLTAGE/VOLTAJE

$\frac{kW}{kcal/h}$   $\frac{V}{Hz}$

PREZZO/PRICE €  
PREIS/PRIX/PRECIO €  
KG / M<sup>3</sup>

**531036700 RETE CON MANIGLIA 60**  
EN grid with handle 60 • DE Raster mit Griff 60 • FR grille avec poignée 60 • ES grid con asa 60  
cm. 43x 31x 22h



**97,00**  
1 / 0,03

**531036800 RETE CON MANIGLIA 80**  
EN grid with handle 80 • DE Raster mit Griff 80 • FR grille avec poignée 80 • ES grid con asa 80  
cm. 63x 31x 22h

**99,00**  
1.5 / 0,05

**531036900 RETE CON MANIGLIA 100**  
EN grid with handle 100 • DE Raster mit Griff 100  
• FR grille avec poignée 100 • ES grid con asa 100  
cm. 83x 31x 22h

**102,00**  
2 / 0,06

**F-1G**  
20029500 **FORNELLONE A PAVIMENTO**  
EN Gas stove • DE Gas-hocherkocker 1 flamming  
• FR Rechaud a gaz • ES Horno a pavimento  
cm. 47x 57x 22,5h



$\frac{9,5 kW}{8.170 kcal/h}$  **426,00**  
10 / 0,14

**FB-1G**  
20029550 cm. 64x 76x 50h



$\frac{9,5 kW}{8.170 kcal/h}$  **566,00**  
15 / 0,53

**FO-1G**  
20029501 **FORNELLONE 1 FUOCO GAS**  
EN Gas table-top stove - 1 burner • DE Gaskocher - 1  
Kochstelle • FR Rechaud a gaz, 1 feu • ES Horno 1  
quemador gas  
cm. 40x 60x 25h



$\frac{5,5 kW}{4.730 kcal/h}$  **629,00**  
13 / 0,13

**FO-2G**  
20029502 **FORNELLONE 2 FUOCHI GAS**  
EN Gas table-top stove - 2 burners • DE Gaskocher, 2  
Kochstellen • FR Rechaud a gaz, 2 feux • ES Horno 2  
quemadores gas  
cm. 70x 60x 25h



$\frac{9 kW}{7.740 kcal/h}$  **989,00**  
22 / 0,22

**FO-3G**  
20029503 **FORNELLONE 3 FUOCHI GAS**  
EN Gas table-top stove, 3 burners • DE Gaskocher, 3  
Kochstellen • FR Rechaud a gaz, 3 feux • ES Horno 3  
quemadores gas  
cm. 105x 60x 25h



$\frac{14,5 kW}{12.470 kcal/h}$  **1.382,00**  
35 / 0,32

MOD. \_\_\_\_\_  
COD. \_\_\_\_\_

DESCRIZIONE/DESCRIPTION/BEZEICHNUNG/DESCRIPTION/DESCRIPCIÓN  
DIMENSIONI/DIMENSIONS/ABMESSUNGEN/DIMENSIONS/DIMENSIONES

POTENZA/POWER/LEISTUNG/PUISSANCE/POTENCIA  
VOLTAGGIO/VOLTAGE/SPANNUNG/VOLTAGE/VOLTAJE

⚡ kW kcal/h  
⚡ kw V~ Hz

PREZZO/PRICE €  
PREIS/PRIX/PRECIO €  
KG / M<sup>3</sup>

**KIT-FO-1FT** **KIT GRIGLIA IN TONDINO 1 FUOCO PER FO-..**  
20029535 **EN** KIT grid rod 1 burner FO-.. • **DE** KIT Gitterstab 1 Brenner FO-.. • **FR** KIT tige grille 1 feux FO-.. • **ES** KIT red de varilla 1 quemador FO-..



**123,00**  
3 / 0,01

**CF-1** **CAVALLETTO INOX PER FO/1G**  
20029511 **EN** Stainless steel stand for FO/1G • **DE** Untergestell für FO/1G • **FR** Support en acier inox pour FO/1G • **ES** Soporte inox para FO/1G  
**cm. 40x 50x 60h**



**363,00**  
17 / 0,18

**CF-2** **CAVALLETTO INOX PER FO/2G**  
20029512 **EN** Stainless steel stand for FO/2G • **DE** Untergestell für FO/2G • **FR** Support en acier inox pour FO/2G • **ES** Soporte inox para FO/2G  
**cm. 70x 50x 60h**

**478,00**  
23 / 0,35

**CF-3** **CAVALLETTO INOX PER FO/3G**  
20029513 **EN** Stainless steel stand for FO/3G • **DE** Untergestell für FO/3G • **FR** Support en acier inox pour FO/3G • **ES** Soporte inox para FO/3G  
**cm. 105x 50x 60h**

**545,00**  
29 / 0,43

**AF-1** **ARMADIETTO CON PORTE PER FO-1G**  
20029521 **EN** Cabinet with wing doors for FO/1G • **DE** Unterschrank mit Flügeltüren für FO/1G • **FR** Placard avec portes pour FO/1G • **ES** Pequeño armario con puertas para FO/1G  
**cm. 40x 53x 60h**



**530,00**  
27 / 0,18

**AF-2** **ARMADIETTO CON PORTE PER FO-2G**  
20029522 **EN** Cabinet with wing doors for FO/2G • **DE** Unterschrank mit Flügeltüren für FO/2G • **FR** Placard avec portes pour FO/2G • **ES** Pequeño armario con puertas para FO/2G  
**cm. 70x 53x 60h**

**773,00**  
33 / 0,35

**AF-3** **ARMADIETTO CON PORTE PER FO-3G**  
20029523 **EN** Cabinet with wing doors for FO/3G • **DE** Unterschrank mit Flügeltüren für FO/3G • **FR** Placard avec portes pour FO/3G • **ES** Pequeño armario con puertas para FO/3G  
**cm. 105x 53x 60h**

**1.180,00**  
39 / 0,43

**PLFO** **PIASTRA LISCIA FORNELLONE**  
20029531 **EN** Smooth griddle plate for gas stove • **DE** Fortkochplatte glatt für Gaskocher • **FR** Plaque lisse pour rechaud • **ES** Plancha lisa para horno  
**cm. 35x 37**



**182,00**  
10 / 0,02

**PRFO** **PIASTRA RIGATA FORNELLONE**  
20029533 **EN** Grooved griddle plate for gas stove • **DE** Fortkochplatte gerillt für Gaskocher • **FR** Plaque rainurée para rechaud • **ES** Plancha estriada para horno  
**cm. 35x 37**

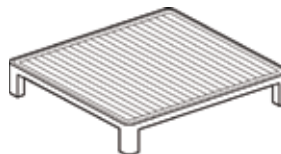

**216,00**  
10 / 0,02

MOD. \_\_\_\_\_  
COD. \_\_\_\_\_

DESCRIZIONE/DESCRIPTION/BEZEICHNUNG/DESCRIPTION/DESCRIPCIÓN  
DIMENSIONI/DIMENSIONS/ABMESSUNGEN/DIMENSIONS/DIMENSIONES

POTENZA/POWER/LEISTUNG/PUISSANCE/POTENCIA  
VOLTAGGIO/VOLTAGE/SPANNUNG/VOLTAGE/VOLTAJE

⚡ kW kcal/h  
⚡ kW V~ Hz

PREZZO/PRICE €  
PREIS/PRIX/PRECIO €  
KG / M<sup>3</sup>

**544439900 ANELLO PER WOK**  
**EN** Wok ring • **DE** Wok Aufsatzring • **FR** Anneau  
 Wok • **ES** Anillo Wok  
**cm. Ø 22,5x 3,5h**

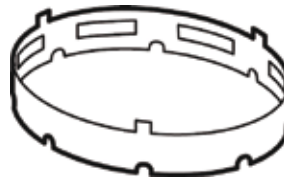

**126,00**  
2 / 0,00

FRY  
FRIGGITRICI



# 10

[www.attrezzaturearredi.it](http://www.attrezzaturearredi.it)

ITALIA

**attrezzature**  **arredi**  
EXPERIENCE EXPERTISE

Via Roberto Bronzetti, 10 - 47922 Rimini (RN)

T. 0541/1781030 - 3 LINEE R.A.

commerciale@attrezzaturearredi.it - [www.attrezzaturearredi.it](http://www.attrezzaturearredi.it)